

Replacement Kits for Sprayers

3A1884E

EN



IMPORTANT SAFETY INSTRUCTIONS

For detailed sprayer information and warnings, see the Operation manual included with your sprayer.

Includes:

Switch Replacement Kits: 16N928, 16P666

Enclosure Replacement Kits: 16P460, 16P461, 16P462, 16P464, 16P465, 16P466, 16P473, 16T446

Motor/Control Board Replacement Kits: 16M861, 16M862, 16P049, 16P427, 16T444, 16T445, 24T887, 24W362

Pump Assembly Replacement Kits: 16M865, 16M867, 16M916

Pump Housing Replacement Kits: 16M868, 16M870, 16T447

Reciprocator Replacement Kits: 16M863, 16M864, 16P051

Drive Housing Replacement Kits: 16M924, 16M925, 16P052

Pressure Relief Procedure

Follow this **Pressure Relief Procedure** whenever you stop spraying and before cleaning, checking, servicing, or transporting equipment.



1. Engage trigger lock.

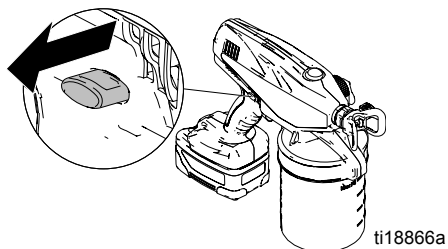

2. Put prime/relief valve UP to release pressure.

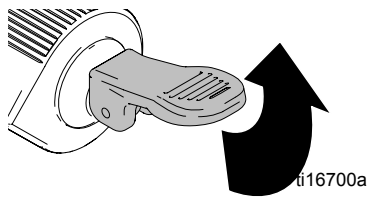

Opening the Sprayer Clamshell

Clamshell Disassembly

1. Perform **Pressure Relief Procedure** (see page 1).
2. Remove battery (or unplug sprayer) and remove cup and suction tube.
3. Remove cup gasket, Made in USA label, and access plug (if applicable).

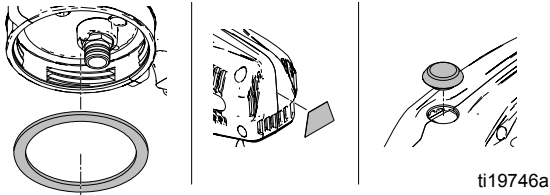

ti19746a

Corded models only: Use a knife to cut cup gasket in half, then peel two pieces out of sprayer. If replacing with a new clamshell, remove serial tag and save for assembly on new clamshell.

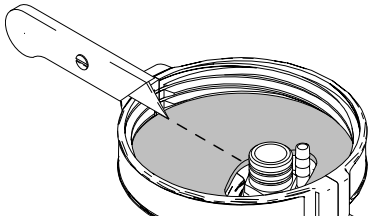

ti19830a

4. Remove prime valve assembly. **NOTE:** If your sprayer does not have a control knob, flip handle up and ignore steps 4a - 4d.

- a. Rotate control knob fully clockwise.

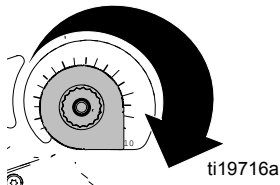

ti19716a

- b. Remove pin from valve handle.

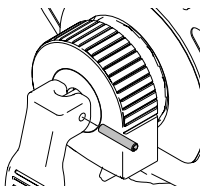

ti19712a

- c. Remove valve handle while in fully clockwise position.

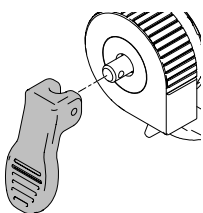

ti19713a

- d. Remove control knob and washer.

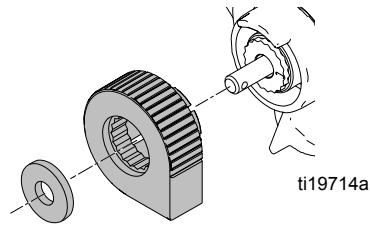

ti19714a

5. Use T15 torx driver to remove nine (or ten depending on model) screws from sprayer enclosure. Remove left half of enclosure by separating rear of enclosure first.

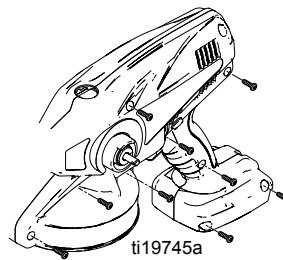

ti19745a

6. **Corded models only:** Use flat screwdriver to pry open snap feature of clamshell.

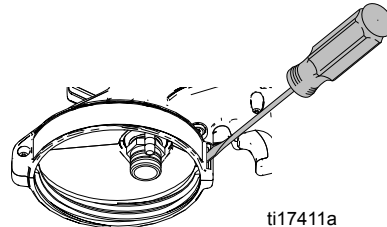

ti17411a

7. Remove trigger lock from left half of enclosure.

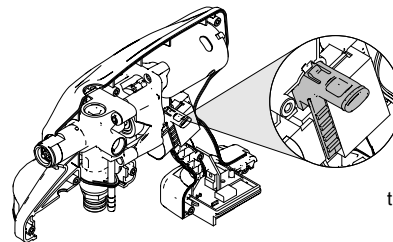

ti19747a

8. Remove pump, motor, drive, and control assembly from right half of enclosure.
9. Proceed to the appropriate page for the replacement kit you are using:

Switch Replacement	Page 6
Motor/Control Board or Drive Housing Replacement	Page 7
Reciprocator Replacement	Page 8
Pump Assembly Replacement	Page 9
Pump Housing Replacement	Page 10

Clamshell Assembly

1. Place right half of enclosure on a flat surface.
2. Carefully place pump, motor, drive, and control assembly in new enclosure and align as shown.

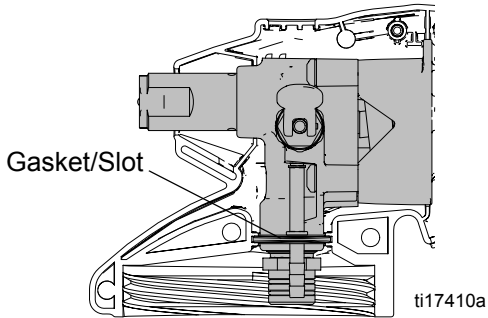

Models 16N658, 16N659, 16N660, 16N661, 16N662, 16N663, 16N673, 16P122, 16N667

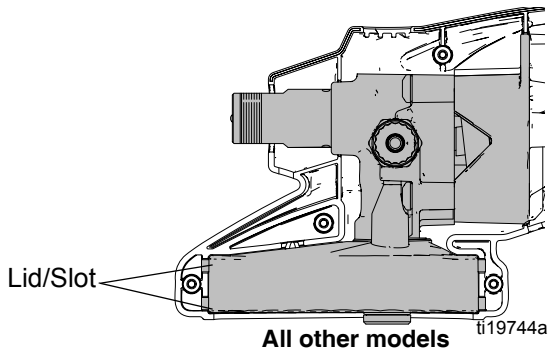

3. Align switch in enclosure, install control boards, and route wires as shown below. **NOTE:** Make sure wires will not be pinched when enclosure halves are put together.

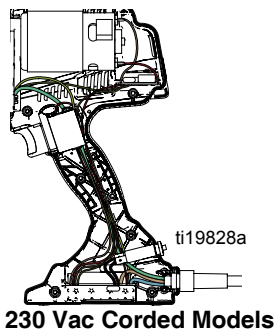
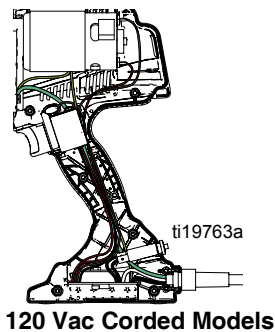
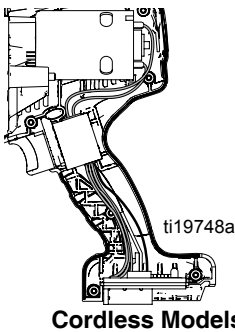

4. Install trigger lock as shown below (there will be a clicking sound when the lock is fully engaged).

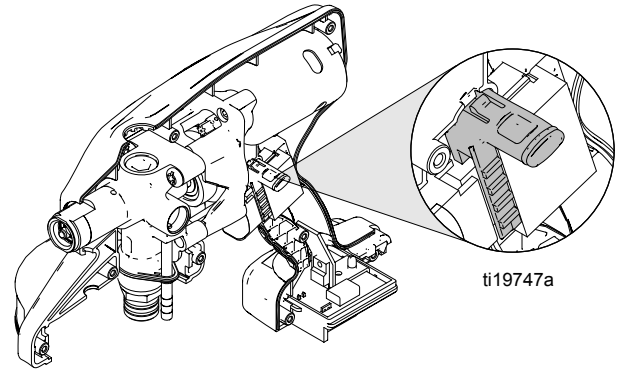

5. **All models:** Install foam filters as shown below. **Cordless models only:** Install battery indicator lens as shown below.

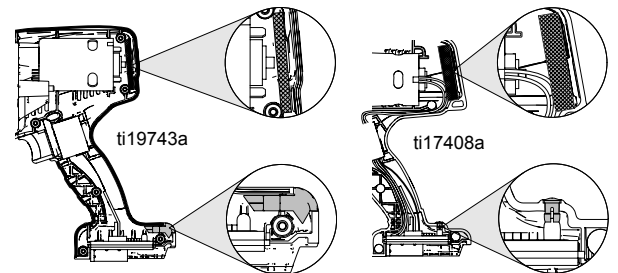

Cordless Models

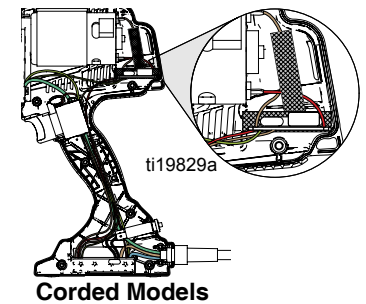

6. Carefully assemble both enclosure halves and snap cup latch into place.
7. **Models 16N658, 16N659, 16N660, 16N661, 16N662, 16N663, 16N673, 16P122, 16N667 only:** Snap cup latch into place.
8. If latches don't snap into place install clamshell clip and screw (not available on all units).

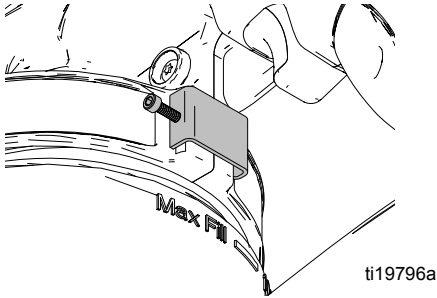

9. Install nine (or ten depending on sprayer) screws into sprayer and use T15 torx driver to tighten. Torque to 8-10 in-lb.

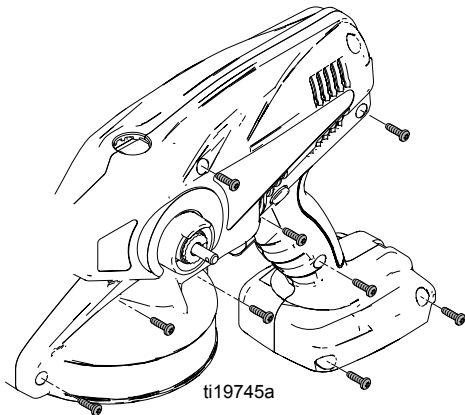

10. Attach Made In USA label, cup gasket, add existing serial tag and install access plug (if applicable).

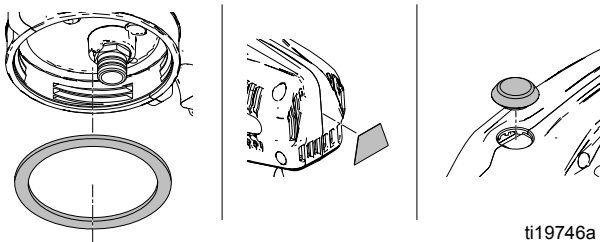

11. Install suction tube, cup, and battery (cordless models only).

12. Assemble prime valve assembly:

NOTE: If your sprayer does not have a control knob, flip handle down and ignore steps 12a-12g.

- a. Use the pressure control knob as a tool to rotate retainer fully clockwise (there should be no gap between retainer teeth and metal valve housing).

NOTE: You may occasionally have to remove, rotate, and reposition pressure control knob due to stop feature molded into back of knob.

- b. Rotate retainer back (counter-clockwise) until the first instance that the line and mark are aligned.

- c. The valve retainer should now protrude approximately 1/8 in. (.30 cm) out from metal valve housing. Your prime/spray valve is now calibrated.

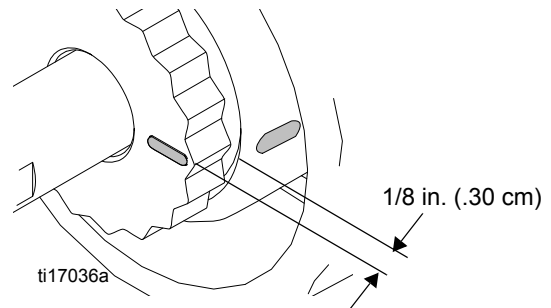

- d. Position pressure control knob in fully clockwise position and press firmly onto retainer.

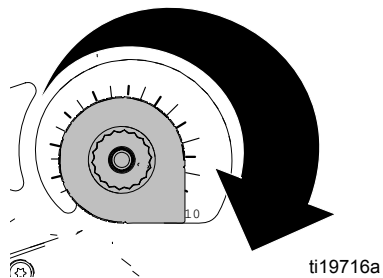

NOTE: You may have to rotate pressure control knob slightly counter-clockwise to fully engage pressure control knob with retainer.

- e. Install washer onto pressure control knob.

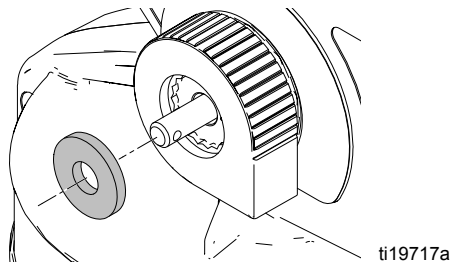

- f. Install valve handle onto stem.

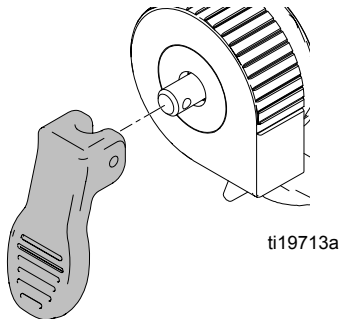

- g. Insert pin into valve handle. Use pliers to press pin into hole.

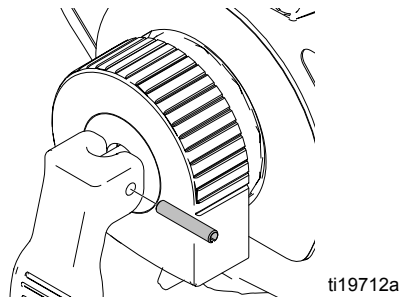

NOTE: If pin does not assemble, repeat steps 12d-12f to ensure pressure control knob is fully engaged with retainer.

IMPORTANT!

After assembly is complete, perform the following steps to verify proper operation. If sprayer fails one of the steps, repeat **Opening the Sprayer Clamshell** procedure.

- Verify proper trigger lock operation. Slide trigger lock into “locked” and “unlocked” position and pull trigger. Trigger should not move in locked position and sprayer should run in unlocked position.
- Visually inspect for gaps between enclosure halves. A gap larger than 1/32 in. could be caused by a pinched wire. If disassembly and inspection indicates that no wire has been pinched, carefully reassemble and repeat verification steps.
- **Cordless Sprayers:** Verify that battery freely slides onto sprayer terminals and is locked when fully engaged.
- Verify belt hook operation (if applicable) by sliding hook completely out and back inside.
- Fill material cup with water and verify unit primes and sprays. Follow setup instructions in sprayer operation manual for proper priming and spraying procedure.
- Rotate pressure control knob to make sure it can rotate fully in both directions.

Switch Replacement

1. Perform **Clamshell Disassembly** procedure, page 2.
2. Loosen four screws on back of switch and disconnect four wires.
3. Replace switch and reattach four wires.
4. Tighten four screws.
5. Perform **Clamshell Assembly** procedure, page 3.

Cordless Models

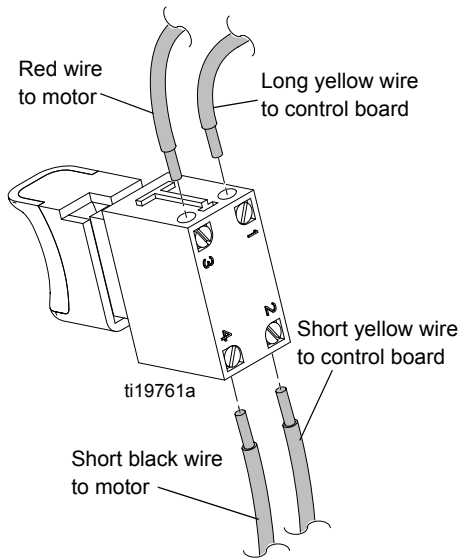

120 Vac Corded Models

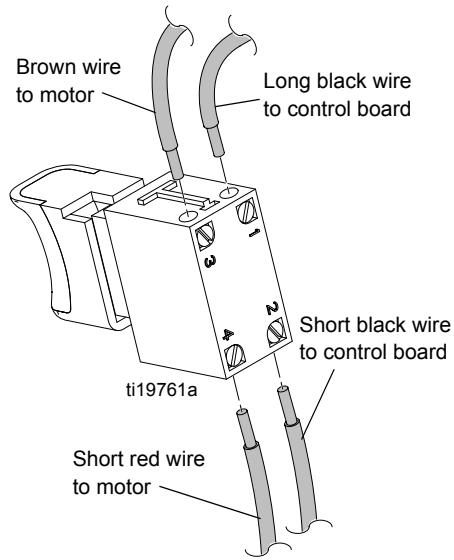

230 Vac Corded Models

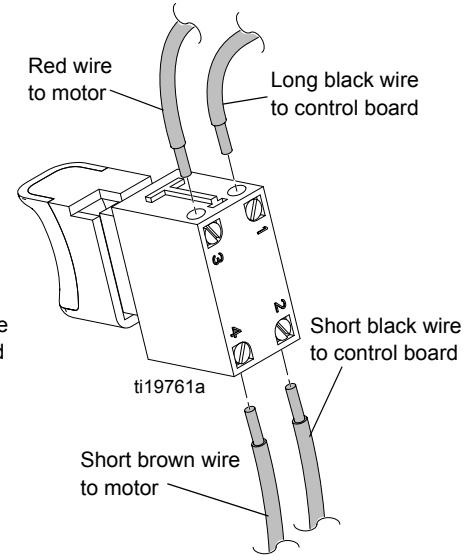

Motor/ Control Board or Drive Housing Replacement

Disassembly

1. Perform **Clamshell Disassembly** procedure, page 2.
2. **Corded models only:** Disconnect all grounding connectors from drive housing. 120 Vac models have two grounding connectors and 230 Vac models have three grounding connectors.

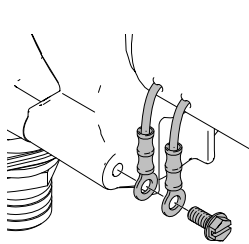

120 Vac Corded Models

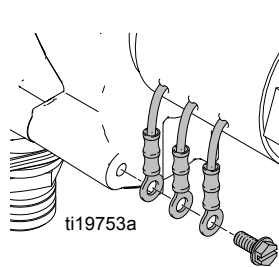

230 Vac Corded Models

3. If applicable, remove drain tube, inlet seal, and cup insert.

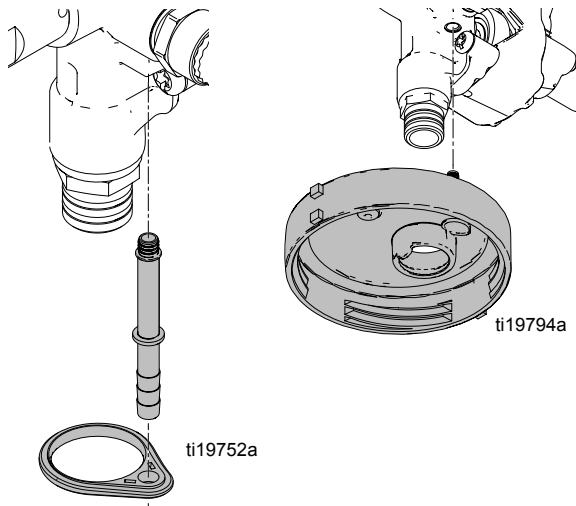

4. Remove four T30 Torx screws separating pump housing and drive housing.

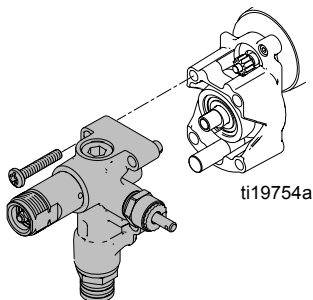

5. Remove reciprocator and large pump piston.

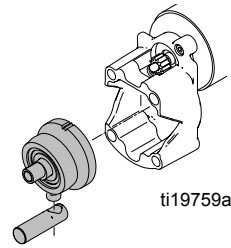

6. Remove two screws separating drive housing and motor.

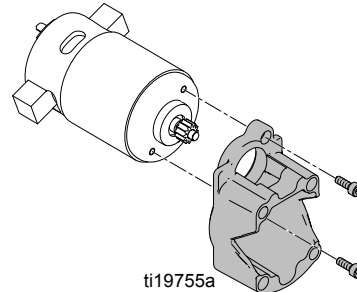

7. Remove motor/control board.

Assembly

1. Replace motor control board.
2. Assemble motor, drive housing and reciprocator and tighten two screws to 29 in-lb (3.3 N•m).
3. Assemble drive housing and pump housing and tighten four Torx screws to 105 in-lb (11.9 N•m).
4. If applicable, install inlet seal, drain tube, and cup insert.
5. **Corded models only:** Reattach all grounding connectors to drive housing with green grounding screw. Torque to 20 in-lb (2.3 N•m). 120 Vac models have two grounding connectors and 230 Vac models have three grounding connectors.

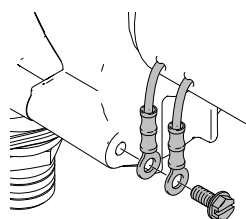

120 Vac Corded Models

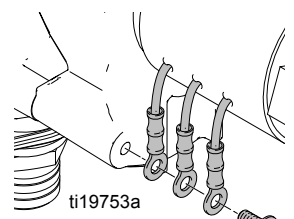

230 Vac Corded Models

6. Perform **Clamshell Assembly** procedure, page 3.

Reciprocator Replacement

Disassembly

1. Perform **Clamshell Disassembly** procedure, page 2.
2. **Corded models only:** Disconnect all grounding connectors from drive housing. 120 Vac models have two grounding connectors and 230 Vac models have three grounding connectors.

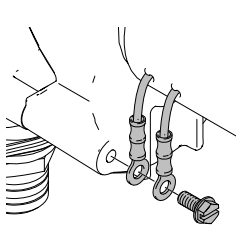

120 Vac Corded Models

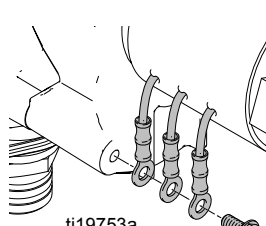

230 Vac Corded Models

3. If applicable, remove drain tube, inlet seal, and cup insert.

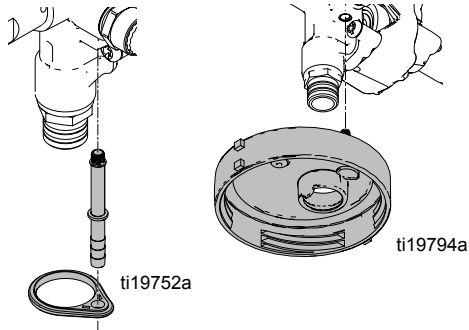

4. Remove four T30 Torx screws separating pump housing and drive housing.

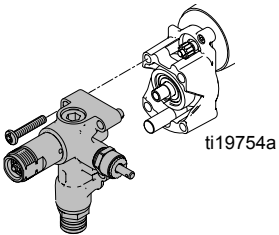

5. Remove reciprocator and large pump piston.

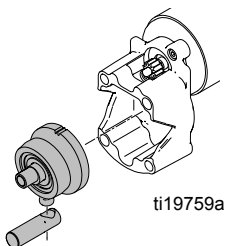

Assembly

1. Assemble motor and drive housing and tighten two screws to 29 in-lb (3.3 N•m).

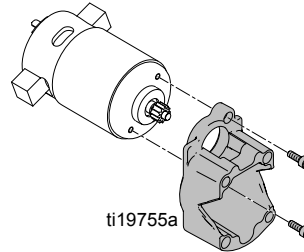

2. Apply supplied lubricant to small piston, face of reciprocator, and cavity of large pump piston.

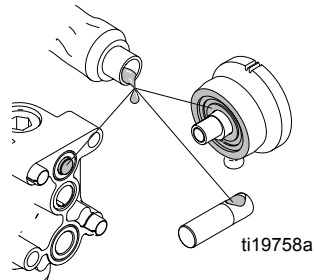

3. Assemble large piston to reciprocator and slide both into pump.

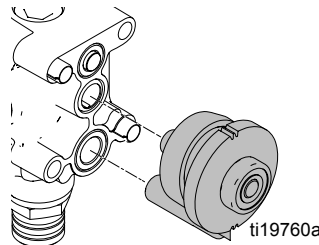

4. Assemble drive housing and pump housing and tighten four Torx screws to 105 in-lb (11.9 N•m).

5. If applicable, install inlet seal, drain tube and cup insert.

6. **Corded models only:** Reattach all grounding connectors to drive housing with green grounding screw. Torque to 20 in-lb (2.3 N•m). 120 Vac models have two grounding connectors and 230 Vac models have three grounding connectors.

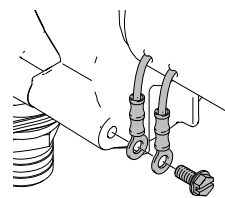

120 Vac Corded Models

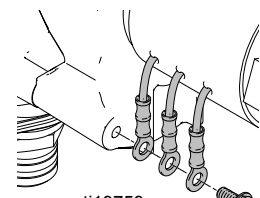

230 Vac Corded Models

7. Perform **Clamshell Assembly** procedure, page 3.

Pump Assembly Replacement

Disassembly

1. Perform **Clamshell Disassembly** procedure, page 2.
2. **Corded models only:** Disconnect all grounding connectors from drive housing. 120 Vac models have two grounding connectors and 230 Vac models have three grounding connectors.

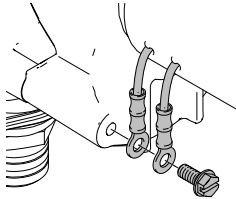

120 Vac Corded Models

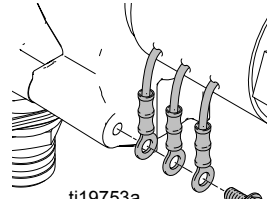

230 Vac Corded Models

3. If applicable, remove drain tube, inlet seal, and cup insert.

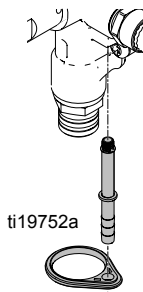

ti19752a

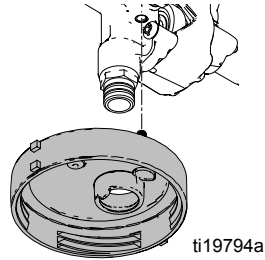

ti19794a

4. Remove four T30 Torx screws separating pump housing and drive housing.

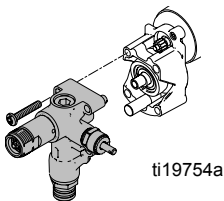

ti19754a

5. Use 7/8 in. wrench to remove needle valve from pump. **NOTE:** Make sure o-ring from back of needle valve is removed from pump.

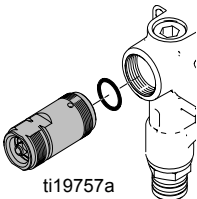

ti19757a

NOTICE

When removing needle valve from pump, avoid crushing threads and damaging parts.

Assembly

1. Install needle valve (see manual 3A0875) and tighten to 150 in-lb (17 N•m). **NOTE:** Make sure o-ring is installed in back of needle valve.
2. Apply supplied lubricant to small piston, face of reciprocator, and cavity of large pump piston.

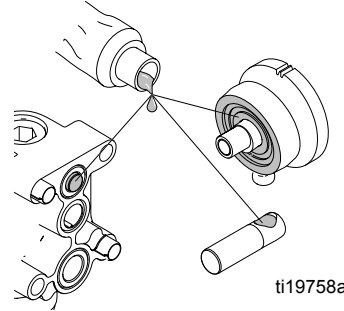

ti19758a

3. Assemble large piston to reciprocator and slide both into pump.

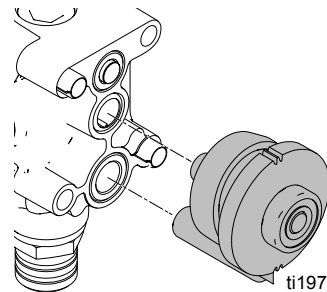

ti19760a

4. Replace drive housing and pump housing and tighten four Torx screws to 105 in-lb (11.9 N•m).
5. If applicable, install inlet seal, drain tube, and cup insert.
6. **Corded models only:** Reattach all grounding connectors to drive housing with green grounding screw. Torque to 20 in-lb (2.3 N•m). 120 Vac models have two grounding connectors and 230 Vac models have three grounding connectors.

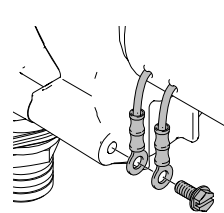

120 Vac Corded Models

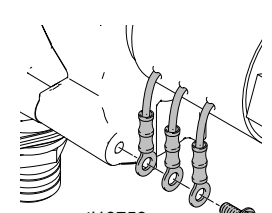

230 Vac Corded Models

7. Perform **Clamshell Assembly** procedure, page 3.

Pump Housing Replacement

Disassembly

1. Perform **Clamshell Disassembly** procedure, page 2.
2. **Corded models only:** Disconnect all grounding connectors from drive housing. 120 Vac models have two grounding connectors and 230 Vac models have three grounding connectors.

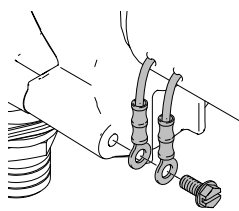

120 Vac Corded Models

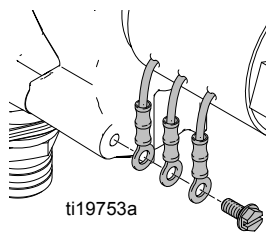

230 Vac Corded Models

3. If applicable, remove drain tube, inlet seal, and cup insert.

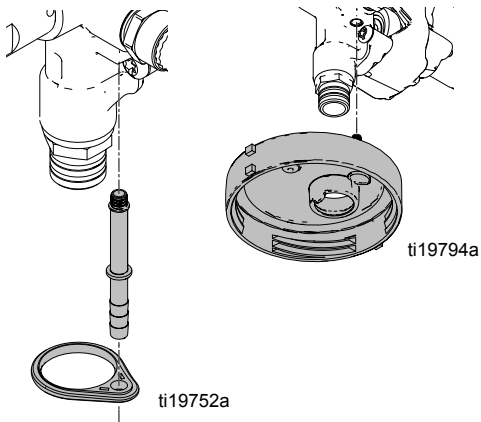

4. Remove four T30 Torx screws separating pump housing and drive housing.

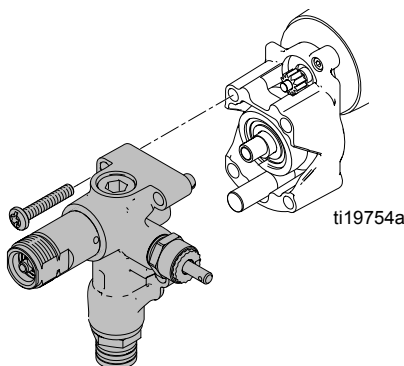

5. Use 7/8 in. wrench to remove needle valve from pump. **NOTE:** Make sure o-ring from back of needle valve is removed from pump.

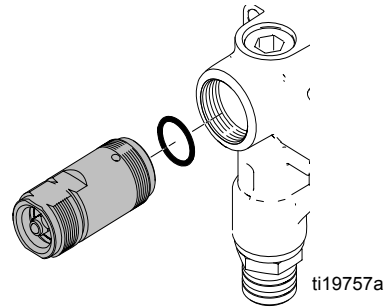

NOTICE

When removing needle valve from pump, avoid crushing threads and damaging parts.

6. Remove outlet valve, and prime valve. **NOTE:** Make sure o-ring comes out when outlet valve is removed.

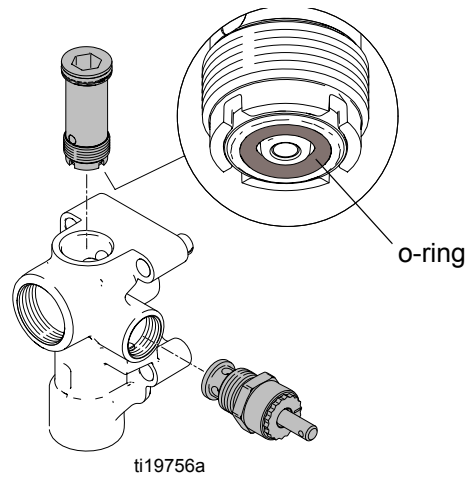

7. Remove inlet valve, inlet poppet valve, poppet o-ring, and spring.

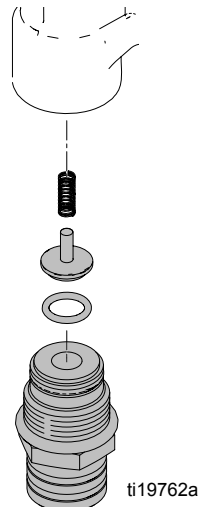

Assembly

1. Install needle valve and tighten to 105 in-lb (11.9 N•m). **NOTE:** Make sure o-ring from back of needle valve is removed from pump.

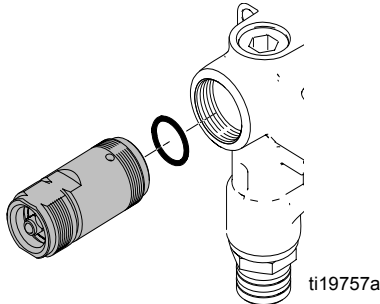

2. Install inlet valve and tighten to 140 in-lb (15.8 N•m). Install outlet valve and tighten to 100 in-lb (11.3 N•m). Install prime valve and tighten to 150 in-lb (17 N•m).

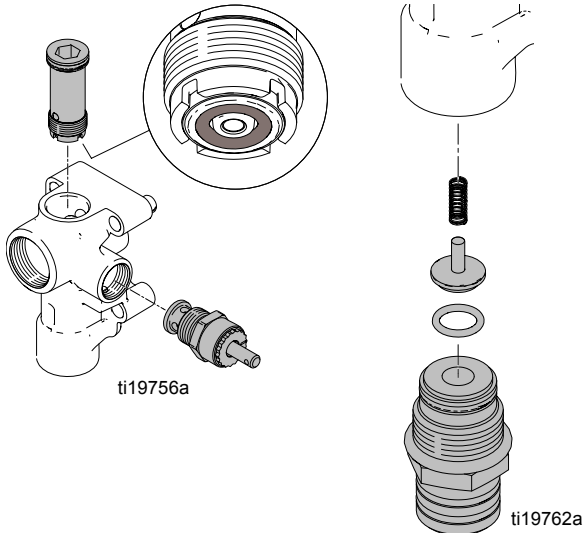

NOTE: Use needle-nose pliers to reinstall inlet poppet valve, poppet o-ring, and spring with inlet valve.

3. Use a pencil or thin rod to lightly push on inlet valve to make sure it moves up and down freely.

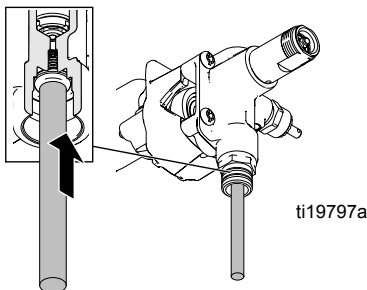

4. Apply supplied lubricant to small piston, face of reciprocator, and cavity of large pump piston.

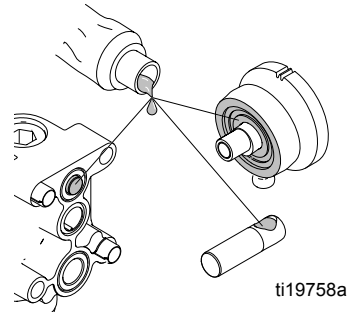

5. Assemble large piston to reciprocator and slide both into pump.

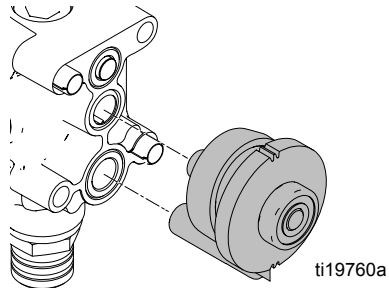

6. Replace drive housing and pump housing and tighten four Torx screws to 105 in-lb (11.9 N•m).

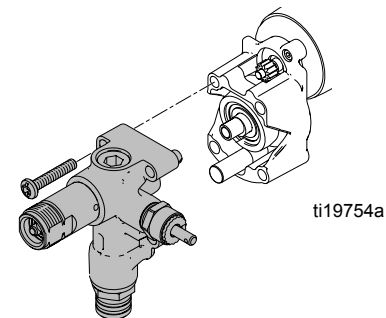

7. If applicable, install inlet seal, drain tube, and cup insert.
8. **Corded models only:** Reattach all grounding connectors to drive housing with green grounding screw. Torque to 20 in-lb (2.3 N•m). 120 Vac models have two grounding connectors and 230 Vac models have three grounding connectors.

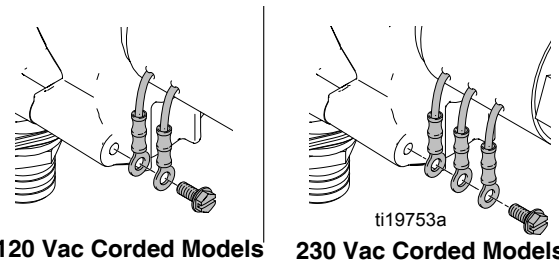

120 Vac Corded Models

230 Vac Corded Models

9. Perform **Clamshell Assembly** procedure, page 3.

*All written and visual data contained in this document reflects the latest product information available at the time of publication.
Graco reserves the right to make changes at any time without notice.*

For patent information, see www.graco.com/patents.

Original instructions. This manual contains English. MM 3A1884

Graco Headquarters: Minneapolis

International Offices: Belgium, China, Japan, Korea

GRACO INC. AND SUBSIDIARIES • P.O. BOX 1441 • MINNEAPOLIS MN 55440-1441 • USA

Copyright 2011, Graco Inc. All Graco manufacturing locations are registered to ISO 9001.

www.graco.com

July 2014