

Kit



FRP Pressure Pots

407032A
EN

For supplying solvent to FRP systems.



Important Safety Instructions

Read all warnings and instructions in FRP system manual. **Save all instructions.**

Part No. 16M893

Part No. 16M894

Parts

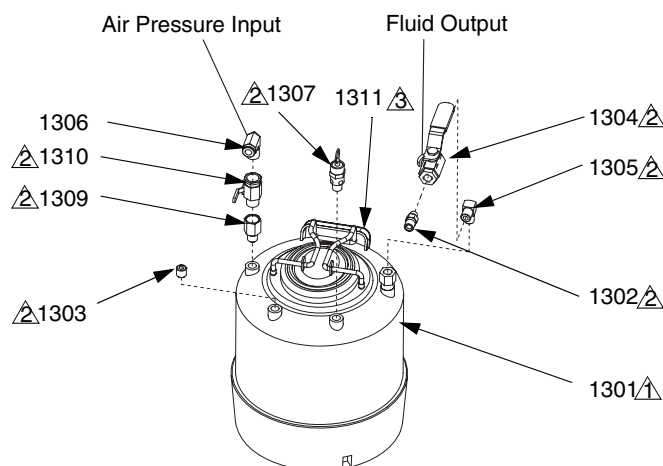

 To assemble strainer (11), remove the dip tube from tank (1). Slide strainer onto bottom end of dip tube. Hold strainer in place while positioning dip tube. Strainer should be secure on tube and pressed to bottom of tank. Tighten dip tube in place. Strainer not shown.

 Apply pipe sealant.

 Clamp ground cable (11) to handle on tank (1). Ground cable not shown.

Ref	Part	Description	Qty
	1306		
	1310		
	1309		
	1303		
	1307		
	1311		
	1304		
	1305		
	1302		
	1301		
	20324-00	TANK, solvent, 2 gallon (16M893 only)	1
	20324-01	TANK, solvent, 5 gallon (16M894 only)	1
	16D939	FITTING, nipple, reducing	1
	11021-23	PLUG, pipe, soc, 1/4	1
	18470-05	VALVE, ball, 2-way, 1/4 nptf	1
	RM-856-04	FITTING, elbow, 1/4 nptm x 1/4 nptm	1
	20655-04	FITTING, elbow, 3/8 nptm x 3/8 tube	1
	103347	VALVE, safety, 100 psi	1
	21035-00	STRAINER, pick-up, material	1
	21462-01	FITTING, adapter, 1/4 nptm x 3/8 nptf	1
	3165	VALVE, ball, 2-way, 3/8 female, 3/8 male	1
	17440-00	CLAMP, grounding	1

All written and visual data contained in this document reflects the latest product information available at the time of publication.

Graco reserves the right to make changes at any time without notice.

For patent information, see www.graco.com/patents.

Original Instructions. This manual contains English. MM 407032

Graco Headquarters: Minneapolis

International Offices: Belgium, China, Japan, Korea

GRACO INC. AND SUBSIDIARIES • P.O. BOX 1441 • MINNEAPOLIS MN 55440-1441 • USA

Copyright 2012, Graco Inc. All Graco manufacturing locations are registered to ISO 9001.

www.graco.com