

# Instructions – Parts List

**QUICK KNOCK DOWN PUMP  
WITH NON-SPARKING CONSTRUCTION**

## **Mining Pump**

307962J

### **10:1 Ratio President Pump**

*1000 psi (7.0 MPa, 70 bar) Maximum Working Pressure*

**222167, Series B**



#### **Important Safety Instructions**

Read all warnings and instructions in this manual.  
Save these instructions.

### **⚠ WARNING**

This pump is specially designed with non-sparking construction. Interchange of any part for repair or improvement of the pump, including the air motor, must be with identical parts bearing the same part numbers given on pages 13–15. To reduce the risk of a fire or explosion and serious injury, the use of any other parts is prohibited.

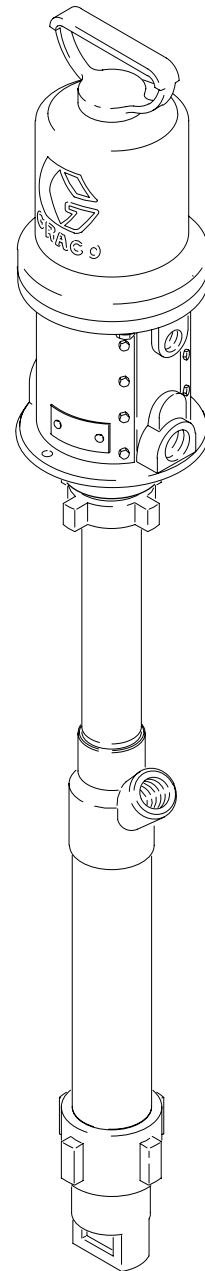

01605

**PROVEN QUALITY. LEADING TECHNOLOGY.**

# Table of Contents

Warnings .....	2
Installation .....	5
Operation .....	6
Troubleshooting .....	9
Air Motor Service .....	10
Displacement Pump Service .....	12
Parts .....	13
Dimensions .....	16
Mounting Hole Layout .....	16
Technical Data .....	17
Warranty .....	18
Graco Information .....	18

# Symbols

## Warning Symbol



This symbol alerts you to the possibility of serious injury or death if you do not follow the corresponding instructions.

## Caution Symbol



This symbol alerts you to the possibility of damage to or destruction of equipment if you do not follow the corresponding instructions.

# ! WARNING



INSTRUCTIONS

## EQUIPMENT MISUSE HAZARD

Equipment misuse can cause the equipment to rupture or malfunction and result in serious injury.

- This equipment is for professional use only.
- Read all instruction manuals, tags, and labels before operating the equipment.
- Use the equipment only for its intended purpose. If you are uncertain about usage, call your Graco distributor.
- Do not alter or modify this equipment. Use only genuine Graco parts and accessories.
- Check equipment daily. Repair or replace worn or damaged parts immediately.
- Do not exceed the maximum working pressure of the lowest rated system component. Refer to the **Technical Data** on pages 17 for the maximum working pressure of this equipment.
- Use fluids and solvents which are compatible with the equipment wetted parts. Refer to the **Technical Data** section of all equipment manuals. Read the fluid and solvent manufacturer's warnings.
- Do not use hoses to pull equipment.
- Route hoses away from traffic areas, sharp edges, moving parts, and hot surfaces. Do not expose Graco hoses to temperatures above 82°C (180°F) or below -40°C (-40°F).
- Wear hearing protection when operating this equipment.
- Do not lift pressurized equipment.
- Comply with all applicable local, state, and national fire, electrical, and safety regulations.

# ! WARNING



## SKIN INJECTION HAZARD

Spray from the gun/valve, hose leaks, or ruptured components can inject fluid into your body and cause extremely serious injury, including the need for amputation. Fluid splashed in the eyes or on the skin can also cause serious injury.



- Fluid injected into the skin might look like just a cut, but it is a serious injury. **Get immediate surgical treatment.**
- Do not point the gun/valve at anyone or at any part of the body.
- Do not put your hand or fingers over the spray tip/nozzle.
- Do not stop or deflect leaks with your hand, body, glove or rag.
- Do not “blow back” fluid; this is not an air spray system.
- Always have the tip guard and the trigger guard on the gun when spraying.
- Check the gun diffuser operation weekly. Refer to the gun manual.
- Be sure the gun/valve trigger safety operates before spraying/dispensing.
- Lock the gun/valve trigger safety when you stop spraying/dispensing.
- Follow the **Pressure Relief Procedure** on page 6 whenever you: are instructed to relieve pressure; stop spraying/dispensing; clean, check, or service the equipment; and install or clean the spray tip/nozzle.
- Tighten all fluid connections before operating the equipment.
- Check the hoses, tubes, and couplings daily. Replace worn, damaged, or loose parts immediately. Permanently coupled hoses cannot be repaired; replace the entire hose.
- Use only Graco approved hoses. Do not remove any spring guard that is used to help protect the hose from rupture caused by kinks or bends near the couplings.



## MOVING PARTS HAZARD

Moving parts, such as the air motor piston, can pinch or amputate your fingers.

- Keep clear of all moving parts when starting or operating the pump.
- Before servicing the equipment, follow the **Pressure Relief Procedure** on page 6 to prevent the equipment from starting unexpectedly.

# WARNING



## FIRE AND EXPLOSION HAZARD

Improper grounding, poor ventilation, open flames or sparks can cause a hazardous condition and result in a fire or explosion and serious injury.



- Ground the equipment and the object being sprayed. Refer to **Grounding** on page 5.
- If there is any static sparking or you feel an electric shock while using this equipment, **stop spraying/dispensing immediately**. Do not use the equipment until you identify and correct the problem.
- Provide fresh air ventilation to avoid the buildup of flammable fumes from solvents or the fluid being sprayed/dispensed.
- Keep the spray/dispense area free of debris, including solvent, rags, and gasoline.
- Electrically disconnect all equipment in the spray/dispense area.
- Extinguish all open flames or pilot lights in the spray/dispense area.
- Do not smoke in the spray/dispense area.
- Do not turn on or off any light switch in the spray/dispense area while operating or if fumes are present.
- Do not operate a gasoline engine in the spray/dispense area.
- This pump is specifically designed with non-sparking construction. Interchange of any parts for repair or improvement of the pump, including the air motor, must be with identical parts bearing the same part numbers given on page 13–15. To reduce the risk of fire or explosion and serious injury, the use of any other parts is prohibited.
- Never use 1,1,1-trichloroethane, methylene chloride, other halogenated hydrocarbon solvents or fluids containing such solvents in pressurized aluminum equipment. Such use could result in a chemical reaction, with the possibility of explosion.



## TOXIC FLUID HAZARD

Hazardous fluid or toxic fumes can cause serious injury or death if splashed in the eyes or on the skin, inhaled, or swallowed.

- Know the specific hazards of the fluid you are using.
- Store hazardous fluid in an approved container. Dispose of hazardous fluid according to all local, state and national guidelines.
- Always wear protective eyewear, gloves, clothing and respirator as recommended by the fluid and solvent manufacturer.

# Installation

## Grounding

**⚠ WARNING**

**FIRE AND EXPLOSION HAZARD**  
Before operating the pump, ground the system as explained below. Also read the section **FIRE AND EXPLOSION HAZARD** on page 4.

To reduce the risk of static arcing, ground the pump and all other spray equipment used or located in the spray area. CHECK your local electrical code for detailed grounding instructions for your area and type of equipment. BE SURE to ground all of this spray equipment:

1. *Pump*: loosen grounding lug locknut (A) and washer. Insert one end of a 12 ga (1.5 mm<sup>2</sup>) minimum groundwire (B) into slot in lug (C) and tighten locknut securely. See Fig. 1. Connect the other end of the wire to a true earth ground. Always check your local code. Order Part No. 237569.
2. *Air hoses*: use only electrically conductive air hoses.
3. *Fluid hoses*: use only electrically conductive fluid hoses.
4. *Air compressor*: follow the manufacturer's recommendations.
5. *Dispensing valve*: grounding is obtained through connection to a properly grounded fluid hose and pump.
6. *Fluid supply container*: according to your local code.
7. *Object being sprayed*: according to your local code.
8. *All solvent pails used when flushing*, according to local code. Use only metal pails, which are conductive, placed on a grounded surface. Do not place the pail on a non-conductive surface, such as paper or cardboard, which interrupts the grounding continuity.
9. *To maintain grounding continuity when flushing or relieving pressure*, always hold a metal part of the valve firmly to the side of a grounded metal pail, then trigger the valve.

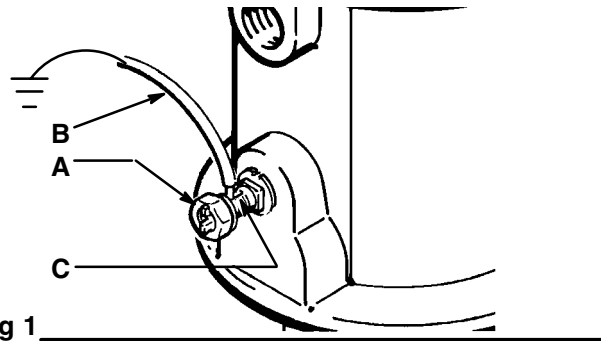

# Operation

## Pressure Relief Procedure

### **WARNING**

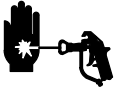

#### **SKIN INJECTION HAZARD**

Fluid under high pressure can be injected through the skin and cause serious injury. To reduce the risk of an injury from injection, splashing fluid, or moving parts, follow the **Pressure Relief Procedure** whenever you:

- are instructed to relieve the pressure,
- stop spraying,
- check or service any of the system equipment,
- or install or clean the spray tips.

1. Shut off the air to the pump. Disconnect the air hose to be sure pressure is relieved in the air motor.
2. If the pump or hose is not clogged and the hose is not closed off, fluid pressure will be relieved.
3. If the pump or hose is clogged, wrap a heavy cloth around the hose coupling at the pump outlet. Slowly unscrew the hose to relieve pressure gradually and reduce splashing.
4. If the clog does not appear to be in the hose, clamp the pump outlet housing in a vise, and hammer the intake valve lug nut to unscrew it. This should relieve pressurized material trapped in the pump.

# Operation

## **⚠ WARNING**

To reduce the risk of static arcing which could result in a fire or explosion and serious injury, use only non-sparking tools if the pump is being assembled or worked on in a hazardous atmosphere.

### Pump Assembly

1. Remove the cotter pin from the connecting rod. Screw the connecting rod into the air motor rod until the pin holes align. Install the pin. Bend the ends of the pin tightly and smoothly around the connecting rod. This is to avoid scratching the cylinder during operation. Push the displacement rod up and engage the threads of the upper lug nut in the air motor base. Hand tighten the lug nut and then secure by tapping the lug nut with a hammer.
2. Connect a grounded air hose to the air inlet. Provide an air regulator to control pump speed and pressure. To help protect the air motor, provide an air motor lubricator.

**NOTE:** If an air motor lubricator is not used, manually lubricate the motor each day. Close the air regulator. Remove the air inlet hose and squirt several drops of SAE 10 motor oil into the air inlet. Attach the hose and run the pump slowly for a couple of minutes to distribute the oil.

3. Connect a suitable hose to the 3/4 npt fluid outlet. Connect a dispensing valve to the hose.
4. Connect a ground wire to the pump grounding lug. Connect the other end of the ground wire to known ground. See **Grounding** on page 5.

### Wet All Internal Parts of the Pump and Hose

A dry pump and hose draws moisture out of the material being pumped, which contributes to pump clogs. To reduce clogging, flush the pump and hose with clean water before priming it with material.

### Regular Operation

1. Mix the material thoroughly to remove all lumps. Pay particular attention to the corners and sides of the mixing container.
2. Mount the pump in the mixing container.

**NOTE:** If the pump was flushed with water, direct the hose into a waste container until all water is displaced with material.

3. Supply air to the pump. Always open the air regulator slowly and then increase pressure gradually until the pump is running smoothly. Use the lowest pressure necessary to give the desired results.

### To Stop Dispensing

Shut off the air supply to the pump and **relieve the pressure.**

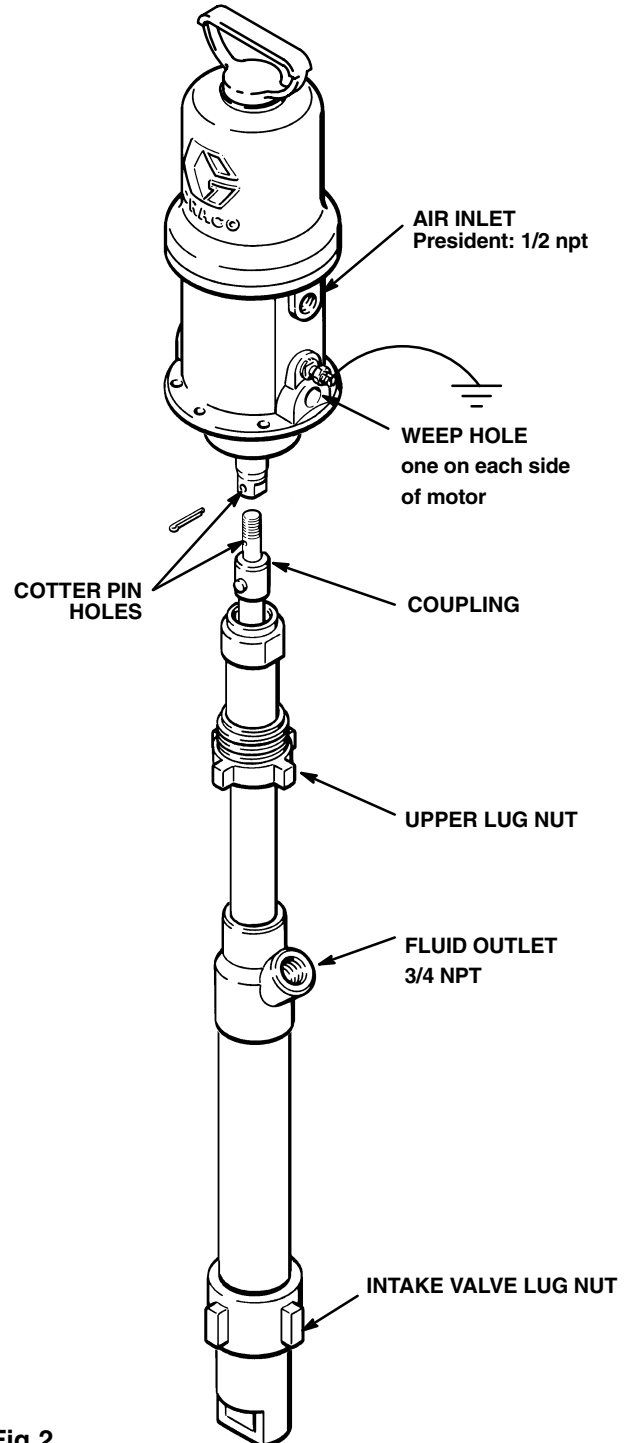

Fig 2

# Operation

## If the Pump Will Not Be Used for Five Minutes or Longer

1. Remove the pump from the mixing container. Turn on the air and direct the material flow into the mixing container. Flush the pump with clean water until thoroughly cleaned. Use the outlet hose to clean the outside of the pump.

**NOTE:** If material has leaked through the weep holes on either side of the motor base, direct the outlet hose into these holes and flush thoroughly.

2. Remove the outlet hose, and then turn the pump upside down to drain. This helps prevent rust.

## If the Pump is Being Stored

Clean the pump thoroughly to reduce rust. Flush with water and disassemble the pump if further cleaning is needed. Turn the pump upside down to drain the water out. Flush again with a rust inhibiting chemical.

## If the Pump or Hose Clogs

### **WARNING**

If the pump or the hose clogs, use extreme caution to avoid splashing material in your eyes while clearing the clog. Follow the procedure below.

1. Shut off the air supply to the motor.
2. Wrap a heavy cloth around the hose coupling at the pump outlet. Slowly unscrew the hose to relieve pressure gradually and reduce splashing.
3. If the clog does not appear to be in the hose, hammer the intake valve lug nut to loosen it and then unscrew it. This should help relieve pressurized material trapped in the pump.
4. Clean the intake valve and reassemble it. Flush the pump.
5. *If the piston check valve is clogged*, relieve pressure. Remove the intake valve and then remove the air motor. See page 10. Push the throat packing assembly out of the pump cylinder. Clean the pump and replace the throat packing assembly. See page 12.
6. If the pump is still clogged, shut off the air to the pump. Disassemble the pump and clean it thoroughly. See page 12.

# Troubleshooting

## WARNING

To reduce the risk of serious injury whenever you are instructed to relieve pressure, always follow the **Pressure Relief Procedure** on page 6.

Before servicing this equipment always make sure to **Relieve the Pressure**.

Check all possible problems and solutions before disassembling the pump.

Problem	Cause	Solution
Excess material leaks from the weep holes in the base of the motor.	Worn throat packings	Flush the weep holes when flushing the pump. Replace the throat packings.
Pump doesn't build pressure.	Worn piston and/or throat packings	Replace the packings.
Pump is clogged.	Material has dried in the pump	Flush pump more frequently; replace packings as needed.
	Material is too dry	Add water.
	Pump and hose not flushed with water before pumping grout	Wet hose and pump with water before pumping grout. See page 7.
Motor leaks air or stops	Lack of lubrication	Rebuild motor, and inject oil into air inlet daily.

## WARNING

This pump is specially designed with non-sparking construction. Interchange of any part for repair or improvement of the pump, including the air motor, must be with identical parts bearing the same part numbers given on pages 13–15. To reduce the risk of a fire or explosion and serious injury, the use of any other parts is prohibited.

# Air Motor Service

## ⚠ WARNING

To reduce the risk of serious injury whenever you are instructed to relieve pressure, always follow the **Pressure Relief Procedure** on page 6.

## ⚠ WARNING

Never operate the pump with the air motor plates removed. The air motor piston, located behind the air motor plates, moves when air is supplied to the motor. Moving parts can pinch or amputate your fingers or other body parts.

## ⚠ WARNING

To reduce the risk of static arcing which could result in a fire or explosion and serious injury, use only non-sparking tools if the pump is being assembled or worked on in a hazardous atmosphere.

**NOTE:** Reference letters in parentheses in the text refer to the figure illustrations.

## Restarting a Stalled Air Motor

1. **Relieve the pressure.** This usually reseats the air transfer valves. Reconnect the air and turn it on.
2. If the air transfer valves do not reseal, screw the cap nut (131) out of the cylinder (115), pull up on the trip rod (101) and screw the cap nut back into the cylinder. See Fig 3.

## Replacing the Throat Bearing

1. Relieve pressure.
2. Disconnect the displacement pump from the motor.
3. Remove the warning plate (128) from the motor base. See Fig 3.
4. Use a 1/4 in. punch to unscrew the bearing (125). See Fig 3.
5. Reassemble in the reverse order of disassembly. Be sure the air motor plates are installed before operating the motor.

## Repairing the Air Motor

## ⚠ CAUTION

To reduce the risk of damaging parts:

Use special pliers, Part No. 207579, when handling the trip rod. Damage to the surface of the trip rod can result in erratic air motor operation.

Always lift the cylinder straight up off the piston. Never tilt the cylinder as it is being removed.

## ⚠ WARNING

Always keep fingers clear of the toggle assemblies (B) to avoid pinching or amputating them. See Fig. 3.

1. **Relieve the pressure.**
2. Remove the displacement pump. See page 12.
3. From below the motor base (102), push up the piston rod. Unscrew the cap nut (131) just until you can pull up the cap nut and then grasp the trip rod (101) with the special padded pliers. Remove the cap nut. See Fig 3.
4. Remove the screws (105). Carefully pull the cylinder straight up off of the piston. See Fig 3.

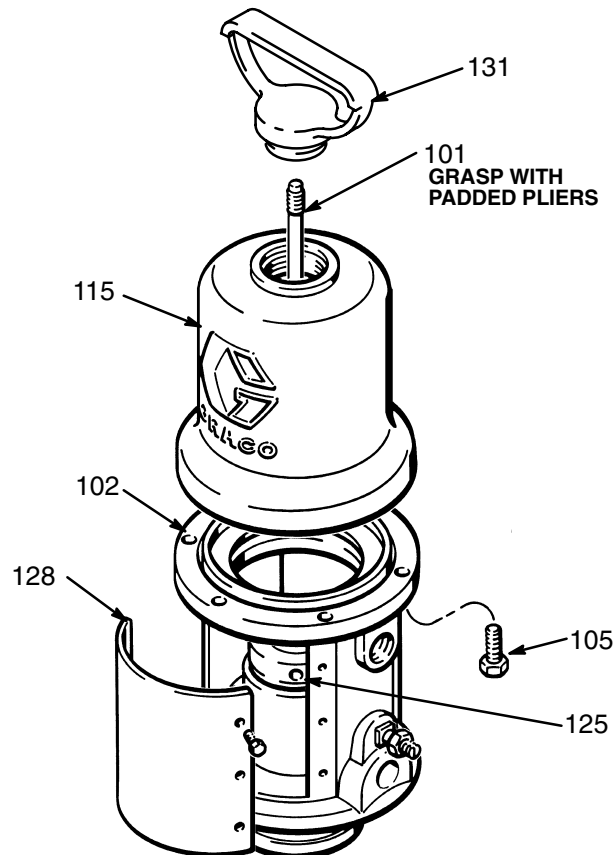

Fig 3

# Air Motor Service

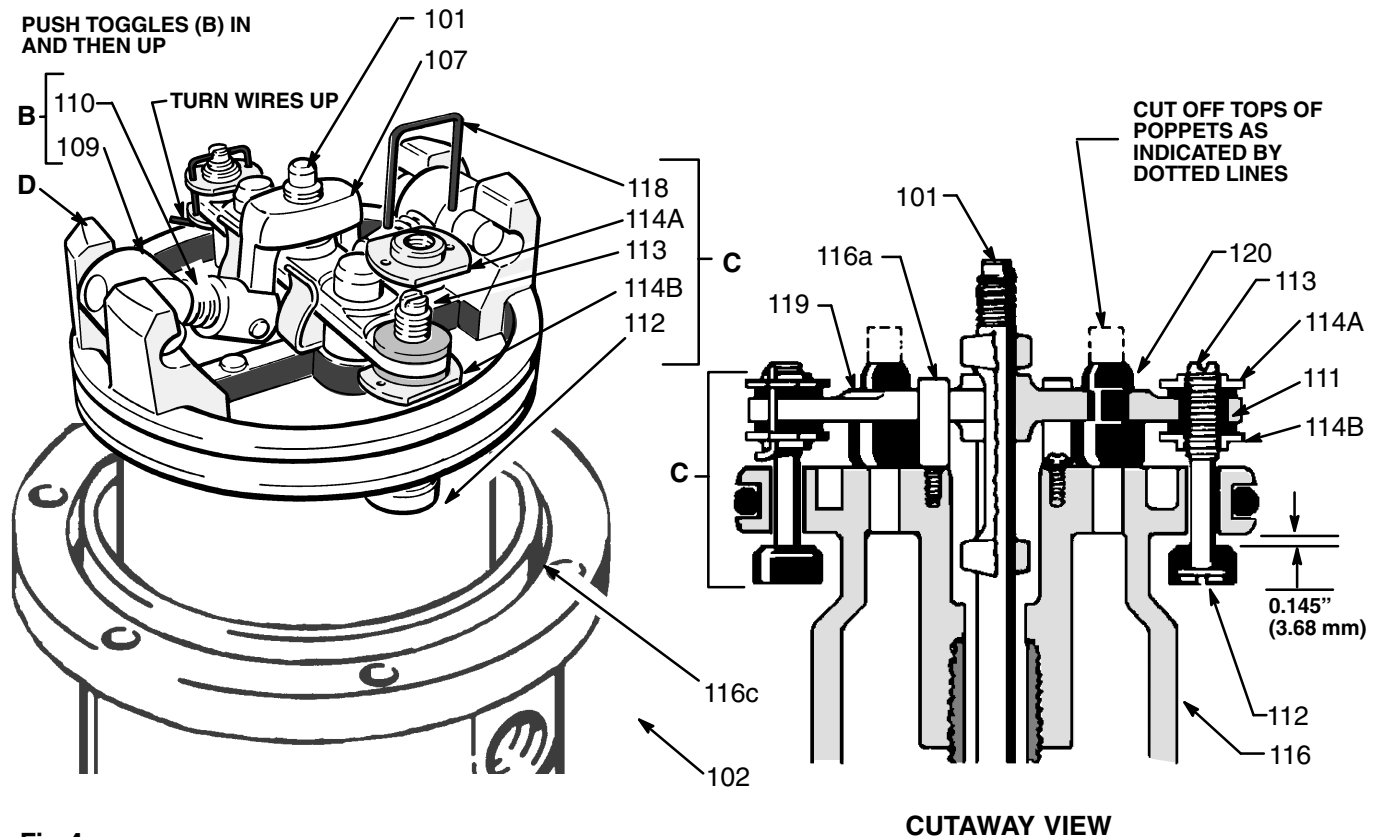

Fig 4

CUTAWAY VIEW

**NOTE:** Refer to Fig. 4 for Steps 5 to 21.

5. Use a screwdriver to push down on the yoke (107) and snap the toggle assemblies (B) down.
6. Remove the lockwires (118) and upper adjusting nuts (114A) from the air transfer valves (C).
7. Screw the stems (113) out of the grommets (111) and lower adjusting nuts (114B).
8. Remove the poppets (112) and inspect them for cracks.
9. Grip the rocker (109) with pliers, compress the spring (110), swing the toggle assembly (B) up and away from the piston lugs (D). Remove the parts.
10. Inspect the actuator (119) to be sure it is supported by the spring clips (116a), but slides into them easily.
11. Remove the yoke (107), actuator (119) and the trip rod (101).
12. Remove the poppets (120): stretch them out and cut them with a sharp knife.
13. Pull the piston (116) out of the base (102). Remove the o-ring (124) in the base casting.
14. Clean all parts thoroughly and inspect for wear or damage. Inspect the polished surfaces of the piston, piston rod and cylinder walls for scratches or wear. Replace parts as necessary. Lubricate all parts with a light waterproof grease.
15. Install the o-ring (124) in the groove inside the base (102). Install the o-ring (123) around the rim of the base. Install the o-ring (121) around the piston (116c). Slide the piston rod down into the base (102).
16. Pull the poppets (120) into the actuator (119) and clip off the top part of the poppets as shown with dotted lines. See the **Cutaway View**.
17. Install the poppets (112) on the stems (113). Reassemble the stems (113), grommets (111), adjusting nuts (114A,114B). Install the wires (118). Turn the ends of the wires up to hold them in place.
18. Install the trip rod (101), actuator (119), yoke (107) and the toggle assemblies (B) on the piston (116).
19. Adjust the stems (113) so there is a 0.145 in. (3.68 mm) clearance between the poppets (112) and the piston (116) when the toggle assemblies are in the down position. See the **Cutaway View**. Special gauge, Part No. 171818, is available.
20. Snap the toggle assemblies (B) to the up position. Reinstall the cylinder (115) and hold the trip rod (101) in place with tool 207579. Apply a medium strength thread locking compound to the threads of the trip rod (101). Torque cap nut (131) to the trip rod (101).
21. Reassemble the air motor to the displacement pump. Before mounting the pump, connect an air hose to the air motor and run the pump to be sure it operates smoothly.

# Displacement Pump Service

## ⚠ WARNING

To reduce the risk of static arcing which could result in a fire or explosion and serious injury, use only non-sparking tools if the pump is being assembled or worked on in a hazardous atmosphere.

## ⚠ WARNING

To reduce the risk of serious injury whenever you are instructed to relieve pressure, always follow the **Pressure Relief Procedure** on page 6.

**NOTE:** A displacement pump repair kit, part no. 224902, is available. Use all the parts in the kit for the best results.

1. **Relieve the pressure.**
2. Lay the pump on a work table.
3. Hammer off the upper lug nut (2). Grasp the outlet housing (10) and pull the displacement pump down until the pin (4) is exposed. Push out the pin.
4. Clamp the intake housing (19) in a vise. Hammer off the lower lug nut (21). Disassemble the intake valve. Inspect the seat in the intake housing (19) for pitting or gouging that would prevent the ball from seating properly and replace the part if necessary. Replace the ball (18) and o-ring (20\*).
5. Tap the displacement rod (3) assembly out the bottom of the pump.
6. Clamp the piston housing (13) in a padded vise. Use a wrench on the flats to unscrew the piston seat (22). Remove the lower u-cup packing (15\*), spacer (27), and the ball (14).
7. Using wrenches on the flats, unscrew the piston rod (12) from the displacement rod (5).
8. Remove the throat packings (8\* and 25\*), washer (24\*) and nut (9).
9. Inspect the cylinders (6 and 11) and the outlet housing (10) for wear or damage. Disassemble these parts only if they are being replaced, and then replace the o-rings (23\* and 20\*), also.
10. Clean all parts thoroughly and inspect for wear or damage. Replace parts as needed.
11. Reassemble the pump in the reverse order of disassembly. Be sure the nut (9) is turned down to the bottom thread of the piston rod (12), before installing the washer and throat packings.

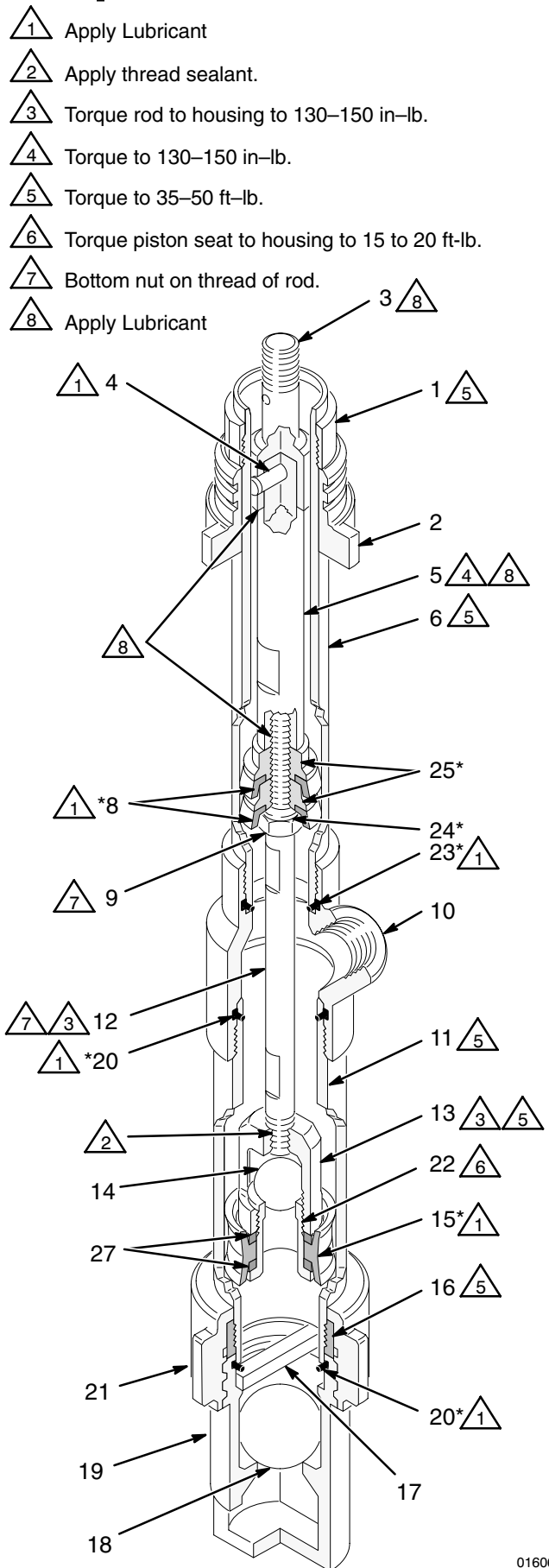

Fig 5

01606

# Parts

## USE GENUINE GRACO PARTS AND ACCESSORIES

### DISPLACEMENT PUMP

#### Model 222173, Series C

Includes items 1 to 27

#### REF

NO.	PART NO.	DESCRIPTION	QTY
1	183934	COLLAR	1
2	183918	NUT, lug	1
3	183928	COUPLING; cst	1
4	222406	PIN, coupling	1
5	183932	ROD, displacement; cst	1
6	183936	CYLINDER, upper; cst	1
8*	188739	PACKING, u-cup, upper; urethane	2
9	100111	NUT, hex jam; 1/2-20	1
10	183914	HOUSING, outlet; cast iron	1
11	183935	CYLINDER, lower; cst	1
12	183931	ROD, piston; cst	1
13	157184	HOUSING, piston; cst	1
14	100279	BALL, piston; cst	1
15*	188738	PACKING, u-cup, lower; urethane	1
16	183933	COLLAR	1
17	183925	PIN, ball stop; cst	1
18	108001	BALL, intake; sst	1
19	183912	HOUSING, intake; cast iron	1
20*	108993	O-RING; buna-N	2
21	183916	NUT, lug	1
22	156989	SEAT, piston; cst	1
23*	105318	O-RING; buna-N	1
24*	109052	WASHER, plain, 1/2"	1
25*	183926	RING, backup; cst	2
26*	110228	PIN, cotter; 1.25"	1
27	187575	SPACER; aluminum	2

\*Included in Repair Kit 224902.  
Purchase separately.

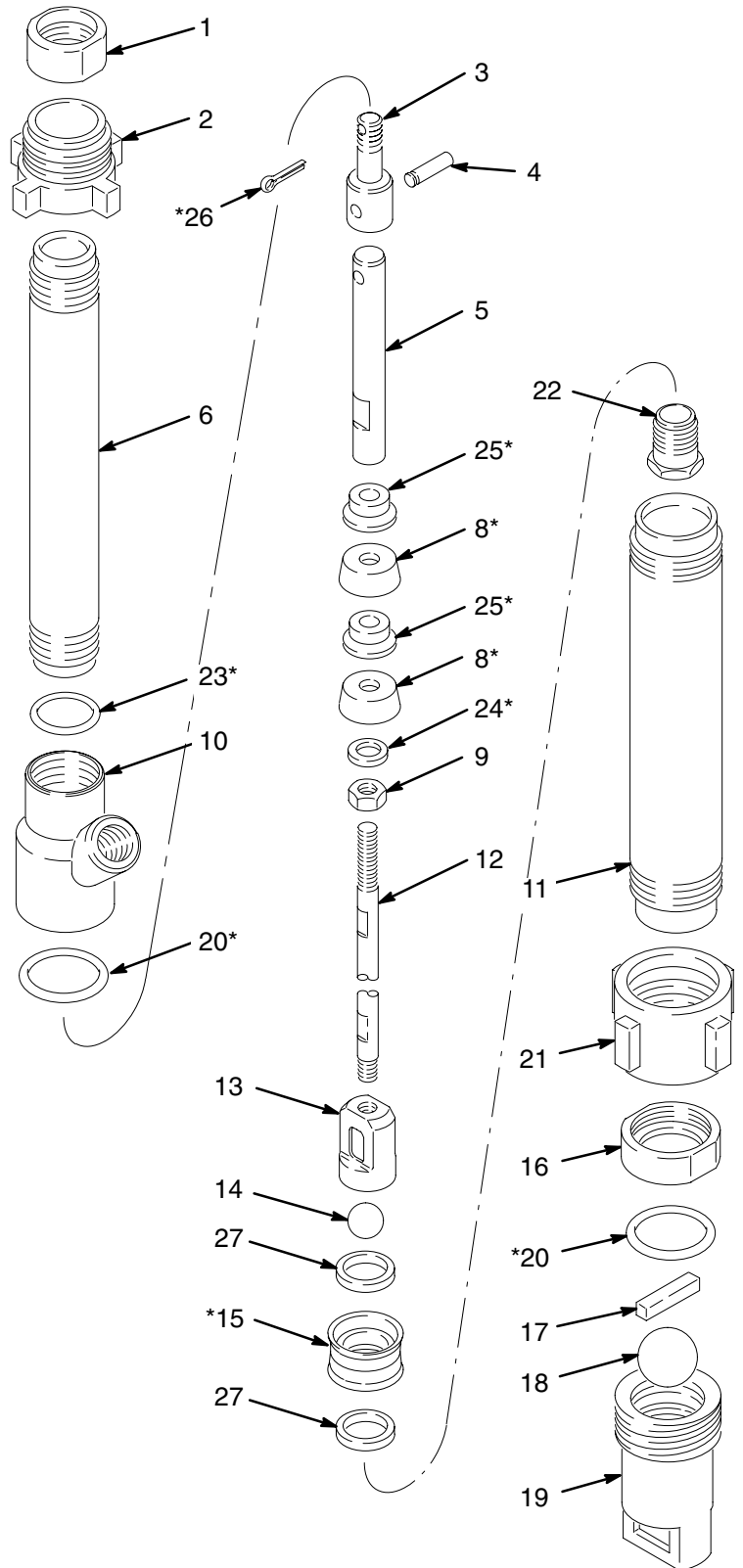

# Parts

## PRESIDENT AIR MOTOR Model 222171, Series B Includes items 101 to 136

REF NO.	PART NO.	DESCRIPTION	QTY
101	207150	TRIP ROD	1
102	183804	BASE, motor, air	1
104	100078	SCREW, hex head, 8-32 x .38 in. lg. 20	1
105	101578	SCREW, hex head, 8-32 x .38 in. lg. 8	8

REF NO.	PART NO.	DESCRIPTION	QTY
106†	156698	O-RING, buna-n	1
107	158360	YOKE, rod, trip	1
108	158362	PIN, toggle	2
109	158364	ROCKER, toggle	2
110	167585	SPRING, compression	2
111*	158367	GROMMET, rubber,	2
112*	170708	POPPET, valve, urethane	2
113*	160896	STEM, valve	2
114*	160261	NUT, adjusting	4
115	183911	CYLINDER, motor, air	1
116	207391	PISTON <i>includes items 116a to 116c</i>	1
116a†	158361	.CLIP, spring	2
116b	102975	.SCREW, rd hd mach; 6-32 x 0.25"	2
116c		.BARE PISTON <i>not sold separately</i>	1
118*	160618	LOCKWIRE, transfer valve	2
119	158359	ACTUATOR, valve	1
120*	170709	POPPET, valve, urethane	2
121*	158378	PACKING, o-ring;nitrile rubber	1
122	160623	ARM, toggle	2
123	158377	SEAL, flat ring;nitrile rubber	1
124*	158379	PACKING, o-ring;nitrile rubber	1
125	222618	PACKING NUT <i>includes items 125a to 125c</i>	1
125a†	110233	.SEAL, wiper, leather	1
125b	101526	.BEARING, bronze	1
125c	166203	.HOUSING, bearing	1
126▲	180233	LABEL, warning	2
127▲	185357	PLATE, WARNING	1
128	185356	PLATE, identification	1
129	150647	GASKET, copper	1
130	166235	ROD, piston	1
131	164704	CAP NUT, with handle	1
132	104582	WASHER, tab	1
133	104029	LUG, grounding	1
134	110228	COTTER PIN	1
135	178270	PLATE, muffler	2
136	183937	SPACER	1

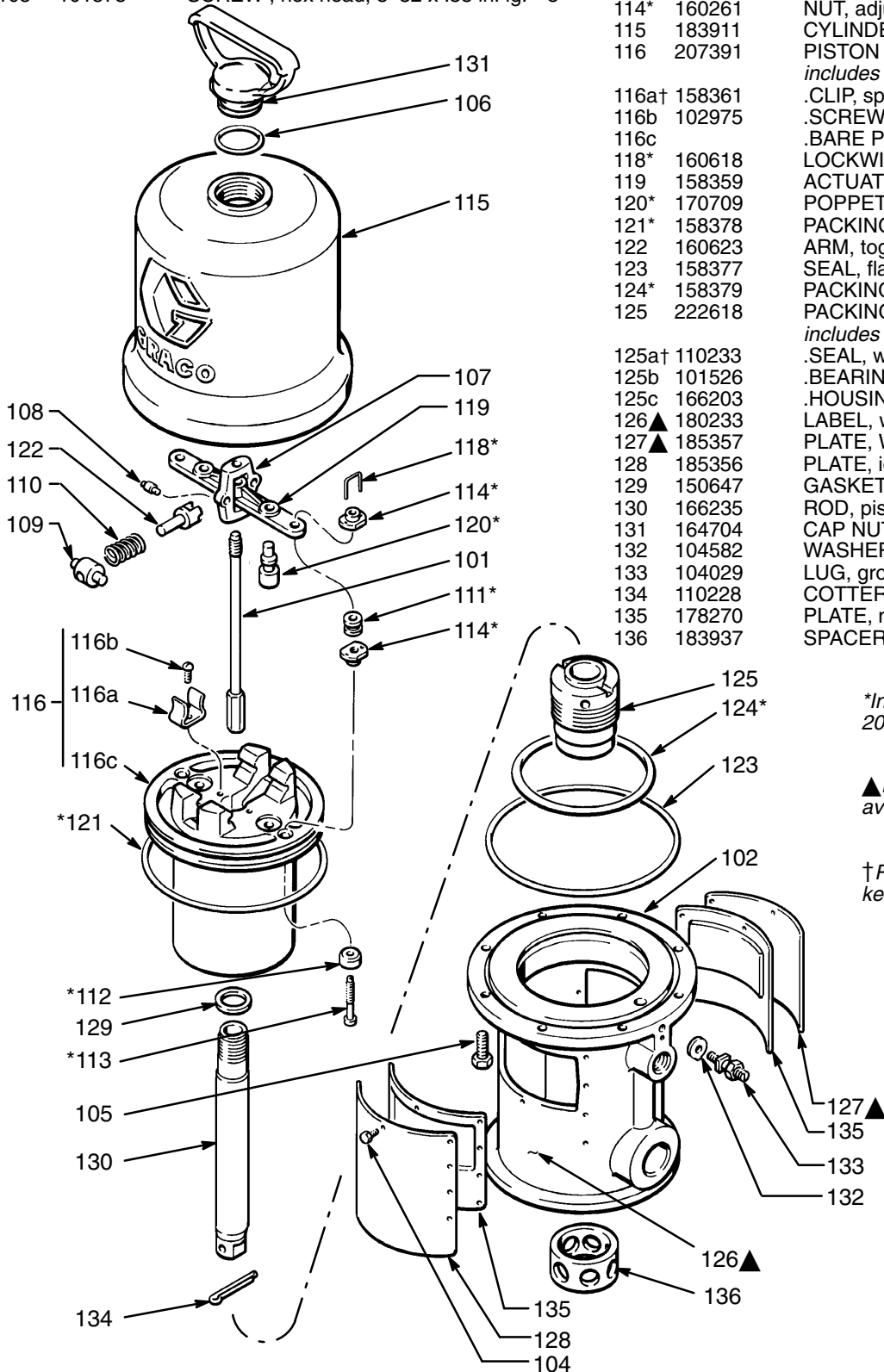

\*Included in Motor Repair Kit 207385. Purchase separately.

▲Extra warning labels and plates available at no cost.

†Recommended spare parts to keep on hand.

# Parts

## PRESIDENT PUMP

### Model 222167, Series B

Includes items 201 to 202

#### REF

NO.	PART NO.	DESCRIPTION	QTY
201	222171	MOTOR, air, President <i>see parts on page 14</i>	1
202	222173	PUMP, displacement <i>see parts on page 13</i>	1

### WARNING

This pump is specially designed with non-sparking construction. Interchange of any part for repair or improvement of the pump, including the air motor, must be with identical parts bearing the same part numbers given on pages 13–15. To reduce the risk of a fire or explosion and serious injury, the use of any other parts is prohibited.

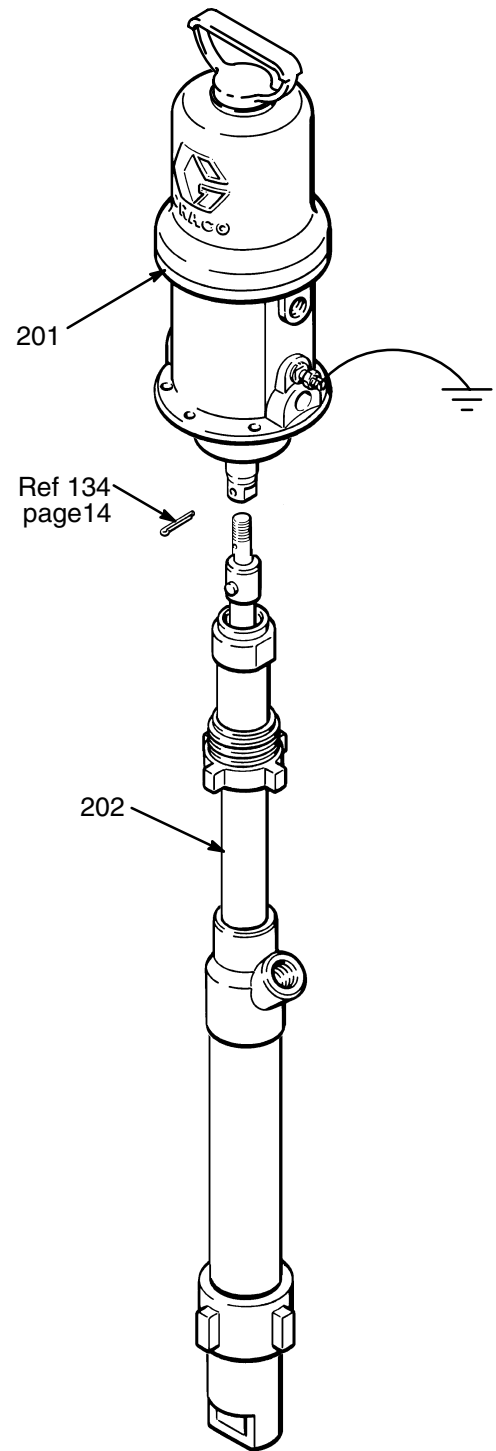

# Dimensions

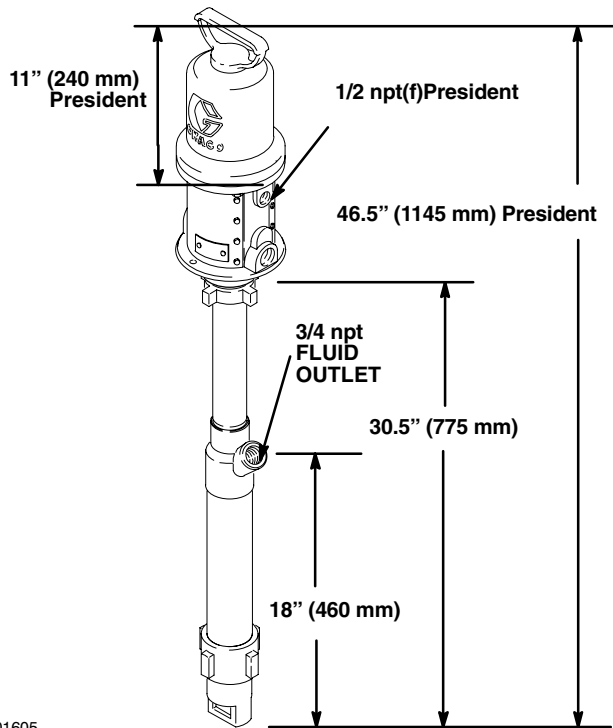

# Mounting Hole Layout

President Air Motor

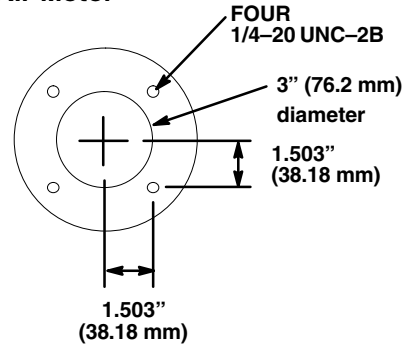

01605

# President Pump – Technical Data

## Pump

Ratio ..... 10:1  
 Maximum Fluid Delivery  
 (Intermittent Duty) ..... 2.6 gpm (10 lpm) at 60 cpm  
 Cycles Per Gallon ..... 23.3  
 Air Operating Range ..... 20 to 100 psi  
 (110–700 kPa, 1 to 7 bar)  
 Maximum Discharge Pressure ..... 1000 psi  
 (7 MPa, 70 bar)  
 Maximum Pump Operating  
 Temperature ..... 140° F (60°C)  
 Air Inlet Size ..... 1/2 npt(f)  
 Fluid Outlet Size ..... 3/4 npt(f)  
 Wetted Parts ..... Cast Iron, Carbon Steel,  
 440 Stainless Steel, Zinc-Plating,  
 Aluminum, Urethane, buna-N  
 Non-wetted Parts ..... Cast Iron, Carbon Steel  
 Weight (pump and motor) ..... 50.5 lb (25.3Kg)

## Motor

Maximum inbound air pressure ..... 100 psi  
 (0.7 MPa, 7 bar)  
 Effective piston area ..... 14 sq. in. (90 cm<sup>2</sup>)  
 Effective piston diameter ..... 4.25" (108 mm)  
 Stroke ..... 4" (102 mm)  
 Air Valves ..... Urethane  
 Valve mechanism ..... Balanced; detented  
 Seal ..... Nitrile rubber  
 Weight ..... 34.5 lb (15.5 kg) approx.

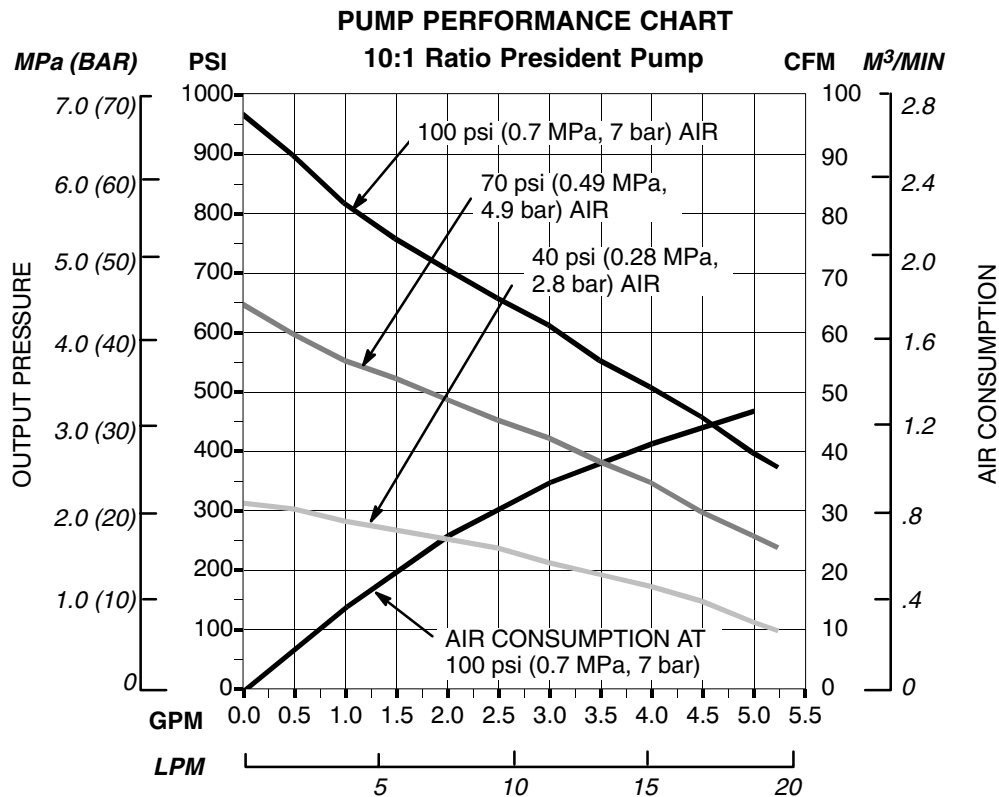

# Graco Standard Warranty

Graco warrants all equipment manufactured by Graco and bearing its name to be free from defects in material and workmanship on the date of sale to the original purchaser for use. With the exception of any special, extended, or limited warranty published by Graco, Graco will, for a period of twelve months from the date of sale, repair or replace any part of the equipment determined by Graco to be defective. This warranty applies only when the equipment is installed, operated and maintained in accordance with Graco's written recommendations.

This warranty does not cover, and Graco shall not be liable for general wear and tear, or any malfunction, damage or wear caused by faulty installation, misapplication, abrasion, corrosion, inadequate or improper maintenance, negligence, accident, tampering, or substitution of non-Graco component parts. Nor shall Graco be liable for malfunction, damage or wear caused by the incompatibility of Graco equipment with structures, accessories, equipment or materials not supplied by Graco, or the improper design, manufacture, installation, operation or maintenance of structures, accessories, equipment or materials not supplied by Graco.

This warranty is conditioned upon the prepaid return of the equipment claimed to be defective to an authorized Graco distributor for verification of the claimed defect. If the claimed defect is verified, Graco will repair or replace free of charge any defective parts. The equipment will be returned to the original purchaser transportation prepaid. If inspection of the equipment does not disclose any defect in material or workmanship, repairs will be made at a reasonable charge, which charges may include the costs of parts, labor, and transportation.

**THIS WARRANTY IS EXCLUSIVE, AND IS IN LIEU OF ANY OTHER WARRANTIES, EXPRESS OR IMPLIED, INCLUDING BUT NOT LIMITED TO WARRANTY OF MERCHANTABILITY OR WARRANTY OF FITNESS FOR A PARTICULAR PURPOSE.**

Graco's sole obligation and buyer's sole remedy for any breach of warranty shall be as set forth above. The buyer agrees that no other remedy (including, but not limited to, incidental or consequential damages for lost profits, lost sales, injury to person or property, or any other incidental or consequential loss) shall be available. Any action for breach of warranty must be brought within two (2) years of the date of sale.

Graco makes no warranty, and disclaims all implied warranties of merchantability and fitness for a particular purpose in connection with accessories, equipment, materials or components sold but not manufactured by Graco. These items sold, but not manufactured by Graco (such as electric motors, switches, hose, etc.), are subject to the warranty, if any, of their manufacturer. Graco will provide purchaser with reasonable assistance in making any claim for breach of these warranties.

In no event will Graco be liable for indirect, incidental, special or consequential damages resulting from Graco supplying equipment hereunder, or the furnishing, performance, or use of any products or other goods sold hereto, whether due to a breach of contract, breach of warranty, the negligence of Graco, or otherwise.

## **FOR GRACO CANADA CUSTOMERS**

The parties acknowledge that they have required that the present document, as well as all documents, notices and legal proceedings entered into, given or instituted pursuant hereto or relating directly or indirectly hereto, be drawn up in English. Les parties reconnaissent avoir convenu que la rédaction du présente document sera en Anglais, ainsi que tous documents, avis et procédures judiciaires exécutés, donnés ou intentés à la suite de ou en rapport, directement ou indirectement, avec les procédures concernées.

# Graco Information

**TO PLACE AN ORDER**, contact your Graco distributor, or call one of the following numbers to identify the distributor closest to you:

**1-800-328-0211 Toll Free**

**612-623-6921**

**612-378-3505 Fax**

*All written and visual data contained in this document reflects the latest product information available at the time of publication.  
Graco reserves the right to make changes at any time without notice.*

This manual contains English. MM 307962

**Graco Headquarters:** Minneapolis  
**International Offices:** Belgium, Korea, China, Japan

**www.graco.com**

307962 05/1995, Revised 07/2007