

ProMix™ Auto

311189L
EN

For proportional mixing of plural component coatings. For professional use only.
For use in explosive atmospheres (except the EasyKey™)



Important Safety Instructions

Read all warnings and instructions in this manual.
Save these instructions.

Wall Mount Fluid Panel

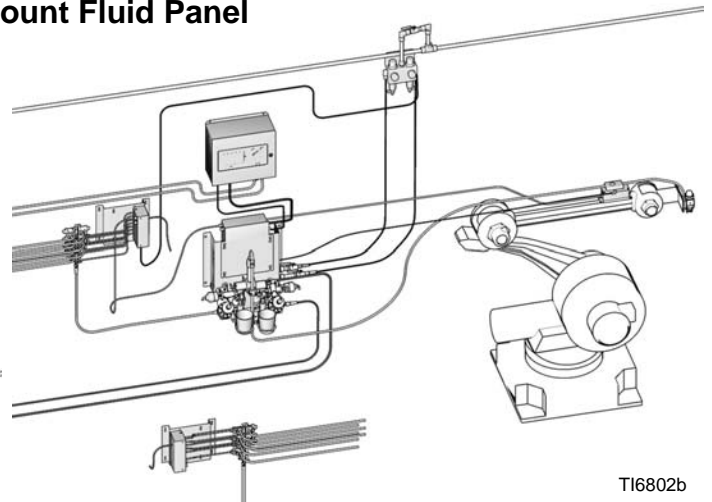

T16802b

RoboMix II

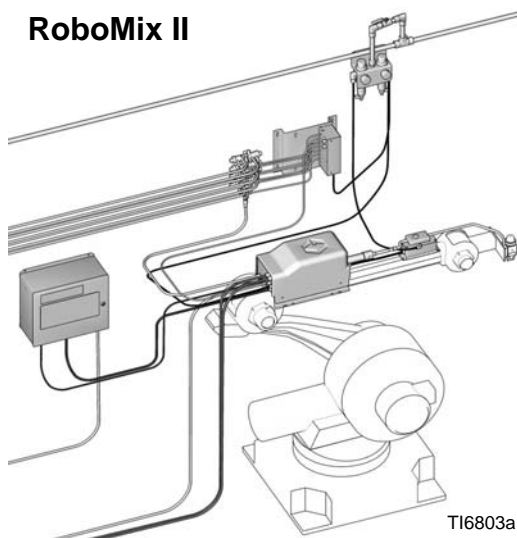

T16803a



Contents

ProMix™ Auto Models	3	Schematics	28
ProMix Auto Smart Part Numbers	4	Pneumatic Diagram	28
RoboMix II Fluid Panel	4	ProMix™ Auto Electrical Schematic	29
Wall Mount Fluid Panel	4	Parts	30
Optional Kits and Equipment	4	ProMix™ Auto Wall Mount Assembly	30
Warnings	5	ProMix™ Auto RoboMix II Assembly	32
ProMix™ Auto ID Plate Locations	7	Wall Mount Fluid Panel	34
Related Manuals	7	Flow Meter Kits	36
Glossary of Terms	8	Control Junction Box	37
Pressure Relief Procedure	10	RoboMix II (Replacement)	38
Shutdown	11	RoboMix II Mix Manifold	41
Troubleshooting	12	EasyKey™ Display	42
ProMix™ Auto Alarms	12	Flow Control Regulator	44
Fluid Manifold Troubleshooting	13	Color Change Control System	45
Solenoid Troubleshooting	14	Technical Data	47
Circuit Board Indicators	15	Graco Standard Warranty	48
Service	18	Graco Information	48
Before Servicing	18		
After Servicing	18		
Replacing Air Filter Element	19		
EasyKey™ Display	20		
Smart Fluid Panels	22		

ProMix™ Auto Models

--	--	--	--	--	--	--

Do not install equipment approved only for a non-hazardous location in a hazardous area. Substitution of components may impair intrinsic safety. See page 5.

--	--	--	--	--	--	--

Changing the fluid manifold configuration may change its pressure rating. Do not exceed the pressure rating of the lowest rated component. See page 5.

Enter Model number here

(See "ProMix Auto Smart Part Numbers" on page 4)

ProMix™ Auto™ Unit	A & B Meters	Color Options	Catalyst	Flow Control

Hazardous Location Approval

only models with a G3000, G250 or G3000HR, G250HR for both A and B meters are approved for installation in a Hazardous Location - Class I, Div I, Group D, T3.



Non-hazardous Location Approval

Maximum Working Pressure

Maximum working pressure rating is dependent on the A and B meter and color change option selected. The pressure rating is based on the rating of the lowest rated fluid manifold component. Refer to the component pressure ratings below. *Example:* Model WP 1640 has a maximum working pressure of 3000 psi (21 MPa, 207 bar).

Check the ID plate on your EasyKey Display or fluid panel for its maximum working pressure. See Fig. 1, page 7.

ProMix™ Auto Fluid Manifold Components Maximum Working Pressure

Wall Mount Fluid Panel Options:

Color Change Option 1, 2, 3 and 4..... 300 psi (2.1 MPa, 21 bar)

Color Change Option 5, 6, 7, and 8..... 3000 psi (21 MPa, 207 bar)

Coriolis A and B Meters Option..... 2300 psi (16 MPa, 159 bar)

No Meters or G3000, G3000HR..... 4000 psi (27.6 MPa, 276 bar)

Wall Mount Modules with Flow Control..... 200 psi (1.4 MPa 138 bar)

RoboMix II Panel Options (all).....190 psi (1.3 MPa, 131 bar)

Flow Meter Fluid Flow Rate Range

G3000, G250 Meter 75-3000 cc/min. (0.02-0.79 gal./min.)

G3000HR, G250HR Meter 38-1500 cc/min. (0.01-0.40 gal./min.)

Coriolis Meter 20-3800 cc/min. (0.005-1.00 gal./min.)

ProMix Auto Smart Part Numbers

RoboMix II Fluid Panel

RP (ProMix Auto)	X = A & B Meter	X = Color Options	X = Catalyst	X = Flow Control
	1 = G250HR 2 = G250	0 = 1 Color 1 = 2 Colors 2 = 4 colors 3 = 7 colors 4 = 15 colors	0 = 1 Catalyst 1 = 2 Catalyst 2 = 4 Catalyst	0 = No 1 = Yes

Wall Mount Fluid Panel

WP (Pro-Mix Auto)	X = A & B Meter	X = Color Options	X = Catalyst	X = Flow Control
	0 = No Meter 1 = G3000 A and B; 2 = G3000HR A and B; 3 = Coriolis A and B; 4 = Coriolis A and G3000HR B	0 = 1 Color 1 = 2 Low Pressure Colors 2 = 4 Low Pressure Colors 3 = 7 Low Pressure Colors 4 =15 Low Pressure Colors 5 = 2 High Pressure Colors 6 = 4 High Pressure Colors 7 = 7 High Pressure Colors 8 =15 High Pressure Colors	0 = 1 Catalyst 1 = 2 Low Pressure Catalyst 2 = 4 Low Pressure Catalysts 3 = 2 High Pressure Catalysts 4 = 4 High Pressure Catalyst	0 = No 1 = Yes







Optional Kits and Equipment

249970	RoboMix II Color Change Kit for 2 colors
249971	RoboMix II Color Change Kit for 4 colors
249972	RoboMix II Color Change Kit for 7 colors
249973	Wall Panel Color Change Kit for 2 colors
249974	Wall Panel Color Change Kit for 4 colors
249975	Wall Panel Color Change Kit for 7 colors
249976	16-23 & 24-30 Color Change Kits
15G614	40 ft. Flow Control Extension Cable
15G711	100 ft. Power Extension Cable
15G710	100 ft. Fiber Cable
234563	Coriolis Meter Kit
15G731	Third Valve Flush for Waterborne Materials





15G701	Ratio Check Kit for RoboMix II (nylon)
15G871	Ratio Check Kit for RoboMix II (SST)
15G634	Modbus/TCP Converter with Cables
253025	Display Interface Replacement Kit
117818	Key, EasyKey Controller
15D979	Fuse, 0.4 Amp, Quick Acting
223547	Ground Wire
15D909	Air Filter Element 5 micron
197902	EasyKey Display Paint Shield
114788	Fuse, 2.0 Amp, Time Lag
249989	EasyKey Software Update Kit

Warnings

The following general warnings are for the setup, use, grounding, maintenance, and repair of this equipment. Additional, more specific warnings may be found throughout the body of this manual where applicable. *Symbols appearing in the body of the manual refer to these general warnings. When these symbols appear throughout the manual, refer back to these pages for a description of the specific hazard.*

 WARNING	
	<p>FIRE AND EXPLOSION HAZARD</p> <p>Flammable fumes, such as solvent and paint fumes, in work area can ignite or explode. To help prevent fire and explosion:</p> <ul style="list-style-type: none"> • Use equipment only in well ventilated area. • Eliminate all ignition sources; such as pilot lights, cigarettes, portable electric lamps, and plastic drop cloths (potential static arc). • Keep work area free of debris, including solvent, rags and gasoline. • Do not plug or unplug power cords, or turn power or light switches on or off when flammable fumes are present. • Ground all equipment in the work area. See Grounding instructions. • Use only grounded hoses. • Hold gun firmly to side of grounded pail when triggering into pail. • If there is static sparking or you feel a shock, stop operation immediately. Do not use equipment until you identify and correct the problem. • Keep a fire extinguisher in the work area.
	<p>INTRINSIC SAFETY</p> <p>Only models with a G3000 or G3000HR for both A and B meters are approved for installation in a Hazardous Location - Class I, Div I, Group D, T2 C. To help prevent fire and explosion:</p> <ul style="list-style-type: none"> • Do not install equipment approved only for non-hazardous location in a hazardous area. See the ID label (FIG. 1) for the intrinsic safety rating for your model. • Do not substitute system components as this may impair intrinsic safety.
 	<p>ELECTRIC SHOCK HAZARD</p> <p>Improper grounding, setup, or usage of the system can cause electric shock.</p> <ul style="list-style-type: none"> • Turn off and disconnect power at main switch before disconnecting any cables and before servicing equipment. • Connect only to grounded power source. • All electrical wiring must be done by a qualified electrician and comply with all local codes and regulations.
 	<p>SKIN INJECTION HAZARD</p> <p>High-pressure fluid from gun, hose leaks, or ruptured components will pierce skin. This may look like just a cut, but it is a serious injury that can result in amputation. Get immediate surgical treatment.</p> <ul style="list-style-type: none"> • Do not point gun at anyone or at any part of the body. • Do not put your hand over the spray tip. • Do not stop or deflect leaks with your hand, body, glove, or rag. • Follow Pressure Relief Procedure in this manual, when you stop spraying and before cleaning, checking, or servicing equipment.

WARNING

	<p>EQUIPMENT MISUSE HAZARD</p> <p>Misuse can cause death or serious injury.</p> <ul style="list-style-type: none"> • Do not operate the unit when fatigued or under the influence of drugs or alcohol. • Do not exceed the maximum working pressure or temperature rating of the lowest rated system component. See Technical Data in all equipment manuals. • Use fluids and solvents that are compatible with equipment wetted parts. See Technical Data in all equipment manuals. Read fluid and solvent manufacturer's warnings. For complete information about your material, request MSDS forms from distributor or retailer. • Check equipment daily. Repair or replace worn or damaged parts immediately with genuine Graco (ASM) replacement parts only. • Do not alter or modify equipment. • Use equipment only for its intended purpose. Call your Graco distributor for information. • Route hoses and cables away from traffic areas, sharp edges, moving parts, and hot surfaces. • Do not kink or over bend hoses or use hoses to pull equipment. • Keep children and animals away from work area. • Comply with all applicable safety regulations.
	<p>MOVING PARTS HAZARD</p> <p>Moving parts can pinch or amputate fingers and other body parts.</p> <ul style="list-style-type: none"> • Keep clear of moving parts. • Do not operate equipment with protective guards or covers removed. • Pressurized equipment can start without warning. Before checking, moving, or servicing equipment, follow the Pressure Relief Procedure in this manual. Disconnect power or air supply.
	<p>TOXIC FLUID OR FUMES HAZARD</p> <p>Toxic fluids or fumes can cause serious injury or death if splashed in the eyes or on skin, inhaled, or swallowed.</p> <ul style="list-style-type: none"> • Read MSDS's to know the specific hazards of the fluids you are using. • Store hazardous fluid in approved containers, and dispose of it according to applicable guidelines.
	<p>PERSONAL PROTECTIVE EQUIPMENT</p> <p>You must wear appropriate protective equipment when operating, servicing, or when in the operating area of the equipment to help protect you from serious injury, including eye injury, inhalation of toxic fumes, burns, and hearing loss. This equipment includes but is not limited to:</p> <ul style="list-style-type: none"> • Protective eyewear • Clothing and respirator as recommended by the fluid and solvent manufacturer • Gloves • Hearing protection

ProMix™ Auto ID Plate Locations



FIG. 1: EasyKey™ Display, Wall Mount Fluid Panel, and RoboMix Fluid Panel ID Plate Locations

Related Manuals

Component Manuals in U.S. English

Manual	Description
311079	ProMix Auto Setup and Operation
311189	ProMix Auto Service - Parts
310654	Fluid Mix Manifold
310655	Dispense Valve
308778	Volumetric Fluid Flow Meter
310696	Coriolis Flow Meter
310656	Color Change Valve Kit
307731	Color Change Valve Assembly, Low Pressure
307941	Color Change Valve, Low Pressure
308291	Color Change Valve Assembly, High Pressure
308977	Color Change Valve, High Pressure
311191	ProMix Auto™ & ProControl™ Network Communications

Glossary of Terms

Air Chop - the process of mixing air and solvent together during the flush cycle to help clean the lines and reduce solvent usage.

Analog - relating to, or being a device in which data are represented by continuously variable, measurable, physical quantities, such as length, width, voltage, or pressure.

Sequential Color Change - the process when a color change is initiated and the system automatically flushes the old color and loads a new color.

Closed Loop Flow Control - refers to the process when the flow rate is adjusted automatically to maintain a constant flow.

Coriolis Meter - a non-intrusive flow meter often used in low flow and light viscosity materials. This meter uses vibration to measure flow. It is used for non-intrinsically safe applications.

Digital Input and Output - a description of data which is transmitted as a sequence of discrete symbols, most commonly this means binary data represented using electronic or electromagnetic signals.

Discrete I/O - refers to data that constitutes a separate entity and has direct communication to another control.

Dose Size - the amount of resin (A) and catalyst (B) that is dispensed into an integrator.

Dose Time Alarm - the amount of time that is allowed for a dose to occur before an alarm occurs.

Ethernet - a method for directly connecting a computer to a network or equipment in the same physical location.

Fiber Optic Communication - the use of light to transfer communication signals.

Fill Time - the amount of time that is required to load mix material to the applicator.

Flow Rate Analog Signal - the type of communication signal that can be used on the ProControl module.

Flow Rate Tolerance - the settable percent of acceptable variance that the system will allow before a flow rate warning occurs.

Flow Set Point - a predefined flow rate target.

Grand Total - a non-resettable value that shows the total amount of material dispensed through the system.

Intrinsically Safe (IS) - refers to the ability to locate certain components in a hazardous location.

Job Total - a resettable value that shows the amount of material dispensed through the system for one job. A job is complete when a color change, purge or complete system flush occurs.

K Factor - a value that refers to the amount of material that passes through a meter. The assigned value refers to an amount of material per pulse.

Ki - refers to the degree fluid flow over shoots its set point.

Kp - refers to the speed in which the fluid flow reaches its set point.

Manual Mode - when the proportioning or flow control system is controlling the inputs without any input from an outside control.

Mix - when cross-linking of the resin (A) and catalyst (B) occurs.

Modbus/TCP - a type of communication protocol used to communicate Digital I/O signals over an ethernet.

Network Station - a means to identify a particular individual proportioning or flow control system.

Overdose Alarm - when either the resin (A) or catalyst (B) component dispenses too much material and the system cannot compensate for the additional material.

Potlife Time - the amount of time before a material becomes unsprayable.

Potlife Volume - the amount of material that is required to move through the mix manifold, hose and applicator before the potlife timer is reset.

PreMix Dump - refers to the time required to flush the lines from the color or catalyst change module to the mix manifold during a color or catalyst change.

PreMix Fill - refers to the time required to fill the lines from the color or catalyst change module to the mix manifold.

Purge - when all mixed material is flushed from the system.

Purge Time - the amount of time required to flush all mixed material from the system.

Ratio Tolerance - the settable percent of acceptable variance that the system will allow before a ratio alarm occurs.

Solvent Fill - the time required to fill the mixed material line with solvent.



Standby - refers to the status of the system.

Third Purge Valve - refers to the use of three purge valves used to flush some water borne materials. The valves are used to flush with water, air and solvent.

Flow Control Resolution - a settable value that allows the flow control system to maximize its performance. The value is based on maximum desired flow rates.

V/P - refers to the voltage to pressure device in the flow control module.

Pressure Relief Procedure

						
<p>Follow Pressure Relief Procedure when you stop spraying, before changing spray tips, and before cleaning, checking, or servicing equipment. Read warnings, page 5.</p>						

1. While in Mix mode (dispensing mix material), isolate the A and B fluid supply.
2. Push the manual override on the A and B dispense valve solenoids to relieve pressure.

 **NOTE: If Dose alarm occurs, clear alarm.**

3. Purge mix material following the Purging section in the ProMix™ Auto Operation Manual (311079).
4. Isolate the solvent fluid supply.
5. Initiate purge sequence following the Purging section in the ProMix™ Auto Operation Manual (311079).
6. Verify the solvent pressure is reduced to 0.

 **NOTE: If Purge Volume alarm occurs, clear alarm.**

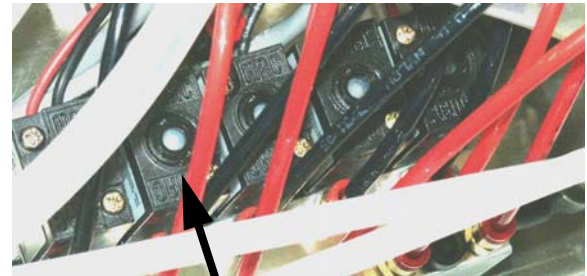

Solenoid Button

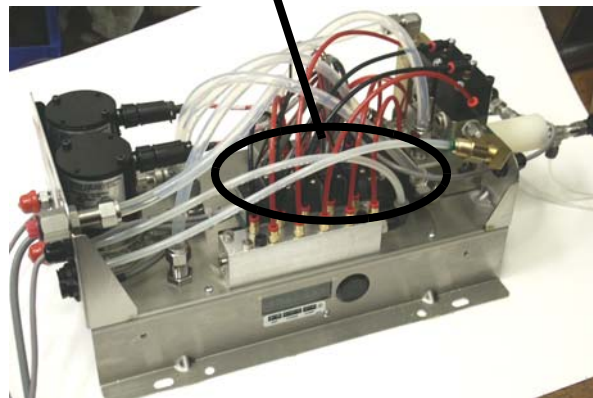
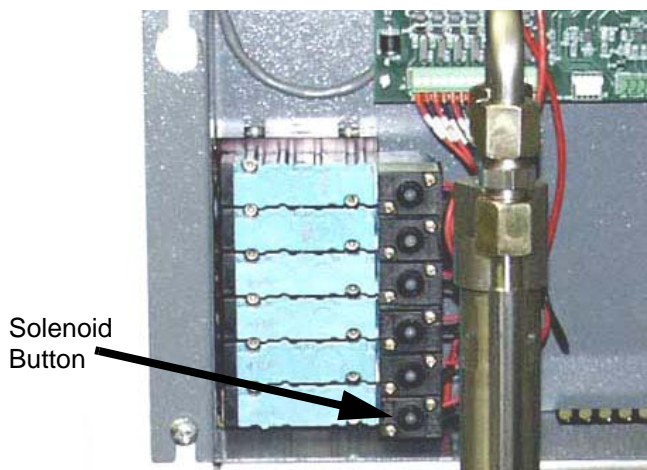





FIG. 3: RoboMix Fluid Supply Solenoids



Solenoid Button

FIG. 2: Wall Mount Fluid Supply Solenoids

Shutdown

						
---	---	---	--	--	--	--

- To avoid electric shock, turn off EasyKey™ power before servicing.
- Servicing EasyKey™ display exposes you to high voltage. Shut off power at main circuit breaker before opening enclosure.
- All electrical wiring must be done by a qualified electrician and comply with all local codes and regulations.
- Do not substitute system components as this may impair intrinsic safety.

Overnight Shutdown

There are two possible procedures for overnight shutdown:

- If flushing the system with solvent is required, run Recipe 0 to purge solvent through meters and gun; see ProMix™ Auto Operation manual (311079).
- If flushing the system with solvent is NOT required, release the gun trigger and put system in Standby mode.

Service Shutdown

1. Follow “Pressure Relief Procedure” on page 10.
2. Close main air shutoff valve on air supply line and on ProMix™ Auto.
3. Shut off ProMix™ Auto power (0 position). FIG. 4.

4. If servicing EasyKey™ Display, also shut off power at main circuit breaker.

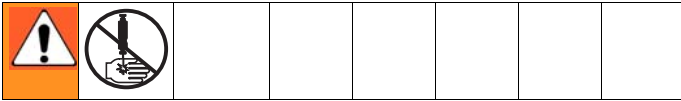

FIG. 4

Troubleshooting

For Additional Information

See ProMix™ Auto Operation manual for additional alarm troubleshooting information.



CAUTION

Do not use the fluid in the line that was dispensed off ratio as it may not cure properly.

ProMix™ Auto Alarms

The ProMix™ Auto has alarms to alert you of a problem and prevent off-ratio spraying. If an alarm occurs, operation stops and the following occurs:

- Alarm sounds.
- Status bar on the EasyKey™ Display shows the alarm description.

To Clear Alarm and Restart

 **NOTE:** When an alarm occurs, determine the error before clearing it. You can use the EasyKey™ Report screen (FIG. 5) to view the most recent 10 alarms with date and time stamps.

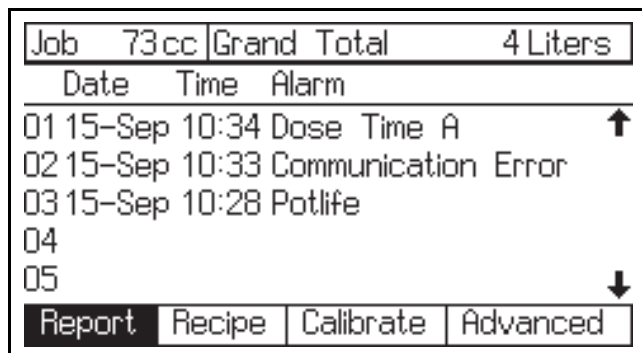

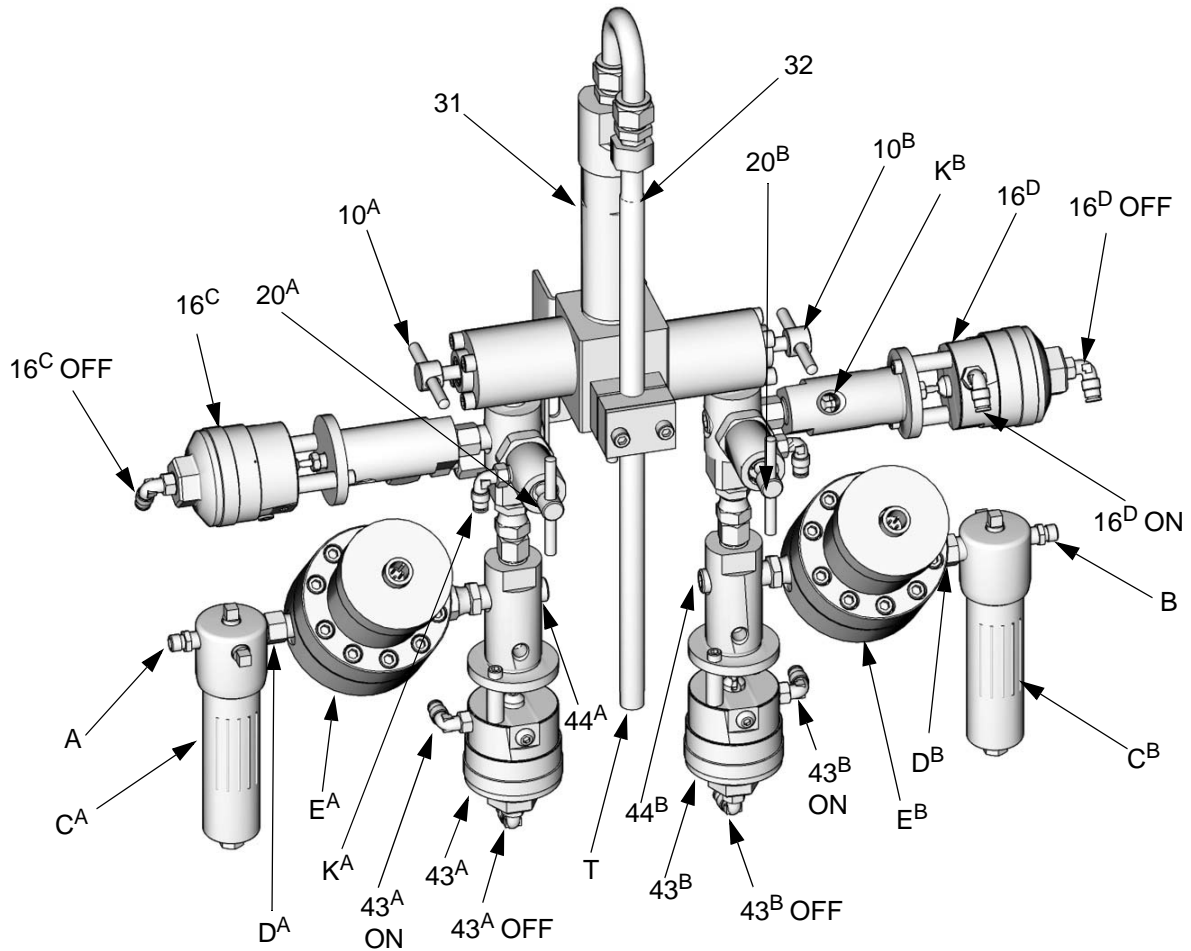

FIG. 5: Setup Mode - Report Screen

NOTE: Use the  or  keys to see all the alarms. The grand total of components A and B is displayed in liters or gallons, based on the units set in Advanced Screen 4. Grand total cannot be reset. There are no selectable settings on the Report Screen.

Fluid Manifold Troubleshooting

See FIG. 6. To remove the fluid manifold, see page 22.
See manual 310654 for complete information on the fluid manifold.



TI7334A

Component A Side

- A Supply Line A connection
- CA Fluid Filter A, 100 mesh
- DA Check Valve A
- EA Flow Meter A (G3000 shown)
- 10A Fluid Shutoff Valve A
- 43A Dispense Valve A
- 16C Air Purge Valve
- 20A Sampling Valve A
- KA Air Purge inlet
- 44A Dump Port A (option)

Component B Side

- B Supply Line B connection
- CB Fluid Filter B, 100 mesh
- DB Check Valve B
- EB Flow Meter B (G3000 shown)
- 10B Fluid Shutoff Valve B
- 43B Dispense Valve B
- 16D Solvent Purge Valve
- 20B Sampling Valve B
- KB Solvent Purge inlet
- 44B Dump Port B (option)

Other

- 31 Integrator
- 32 Static Mixer
- T Mixer Fluid Outlet to gun

FIG. 6. 248251 Fluid Manifold

Solenoid Troubleshooting

 **NOTE:** Refer to the Pneumatic Diagram, page 28.

If the dispense, purge, or dump valves are not turning on or off correctly, it could be caused by one of the following.

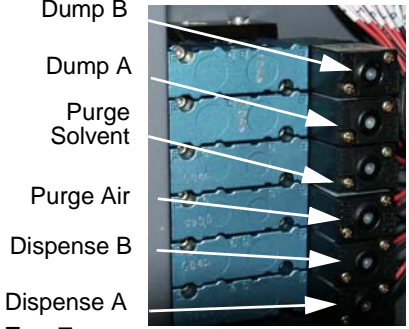
Cause	Solution
<p>1. Air regulator pressure set too high or too low.</p>	<p>Check air pressure. 80 psi (550 kPa, 5.5 bar) is commonly used. Do not go below 75 psi (517 kPa, 5.2 bar) or above 100 psi (0.7 MPa, 7 bar),</p>
<p>2. Air or electrical lines damaged or connections loose.</p>	<p>Visually inspect air and electrical lines for kinks, damage, or loose connections. Service as needed.</p>
<p>3. Solenoid failure</p>  <p>FIG. 7</p>	<p>Manually operate the valves by removing the Fluid Panel cover and pressing and releasing solenoid valve override buttons. FIG. 7. Fluid valves should operate when solenoid override is activated.</p> <p>Use the control board diagnostics to check the signals (page 15). If signals do not occur correctly, go to Cause 4.</p> <p>Valves should snap open and shut quickly. If the valves actuate slowly, it could be caused by:</p> <ul style="list-style-type: none"> • Air pressure to the valve actuators is too low. See Cause 1. • Solenoid is clogged. Make sure air supply has 5 micron filter installed. • Something is restricting the solenoid or tubing. Check for air output from air line for corresponding solenoid when valve is actuated. Clear restriction. • Packings on the mix manifold dispense valves are too tight. Torque should be 25 in-lbs (2.8 N•m). (Wall Mount Fluid Panel only.) • Dispense Valve Travel Adjustment (Wall Mount Fluid Panel only) is turned in too far. See ProMix™ Auto Operation manual for settings. • Fluid pressure is high and air pressure is low.
<p>4. Solenoid, cable, or fluid panel control board failure.</p>	<p>Check voltage level to solenoid by pulling solenoid connector and checking voltage between pins.</p> <p>If voltage is 9-15 VDC, the solenoid is damaged. Replace solenoid or correct electrical line problem.</p> <p>If there is no voltage, replace the board.</p> <p>Check circuit board LEDs.</p>

Circuit Board Indicators

Part Number	Board	Button	LED
249306	Display	SW2 - Force software upgrade when held at power-on.	D1 - 1-second heartbeat
249183	Ethernet	none	Two LEDs on bottom. Left is network connection. Right is network activity.
249179	Fluid Regulator	none	none
249190	Fluid Plate	S2 - Force software upgrade when held at power on. Not at power on, hold for 10 seconds to reset pressure flow table.	D4 - 1-second heartbeat
			D44 - Dispense A
			D43 - Dispense B
			D34 - Purge A - Air
			D36 - Purge B - Solvent
			D28 - Purge C - Water
			D30 - Dump A
			D27 - Dump B
			D15 - not used
			D45 - Solvent Flow Switch
249437	Color Change	S1-S8: Push to test solenoids	D1 - 1-second heartbeat
		SW1 - Rotary switch to set address	
		JP1 - Jumper to select last module	

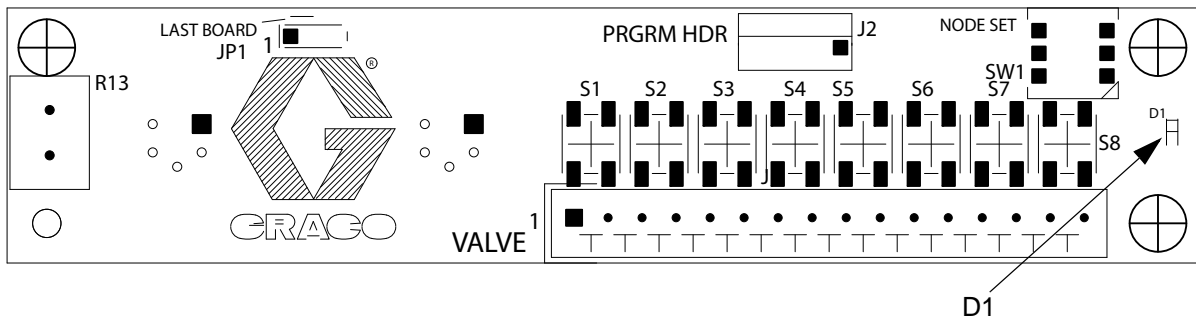

FIG. 8: Part Number 249437

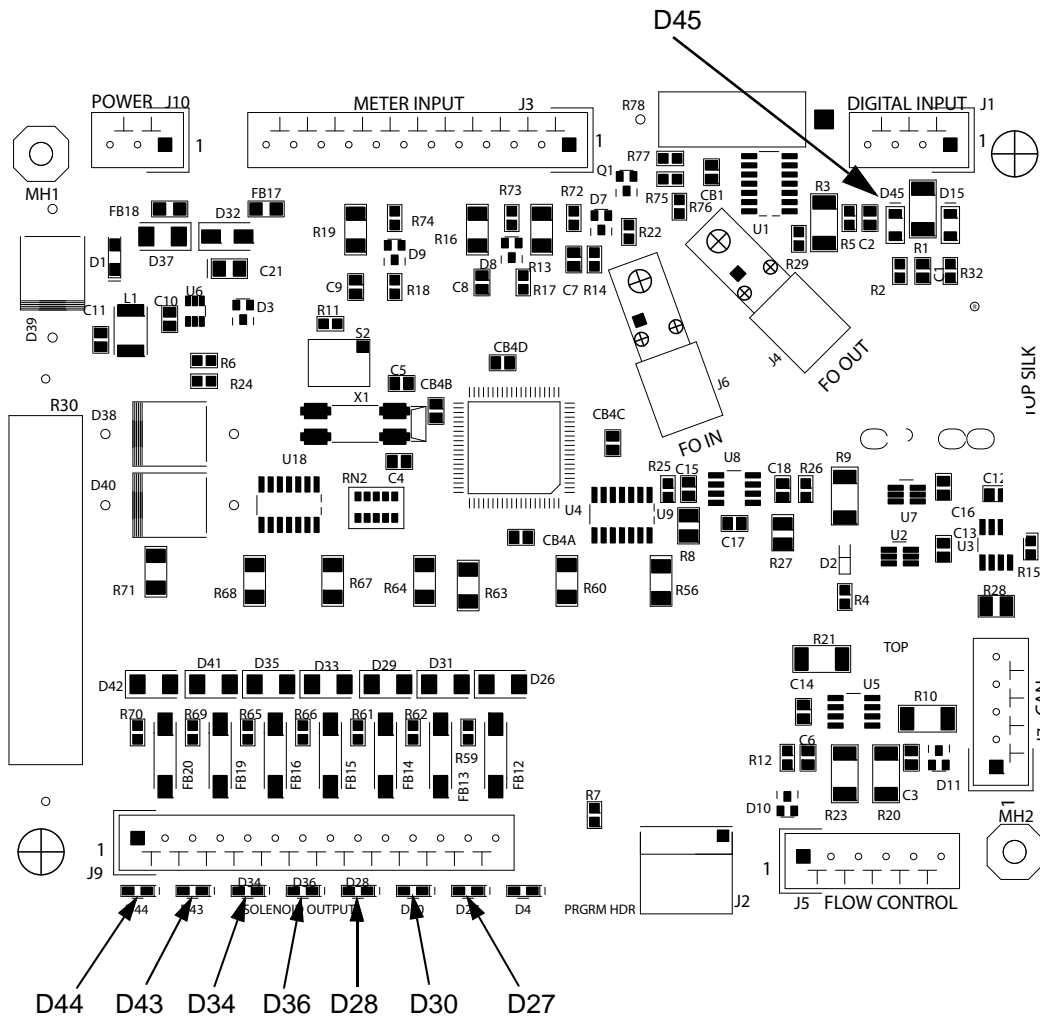

FIG. 9: Part Number 249190

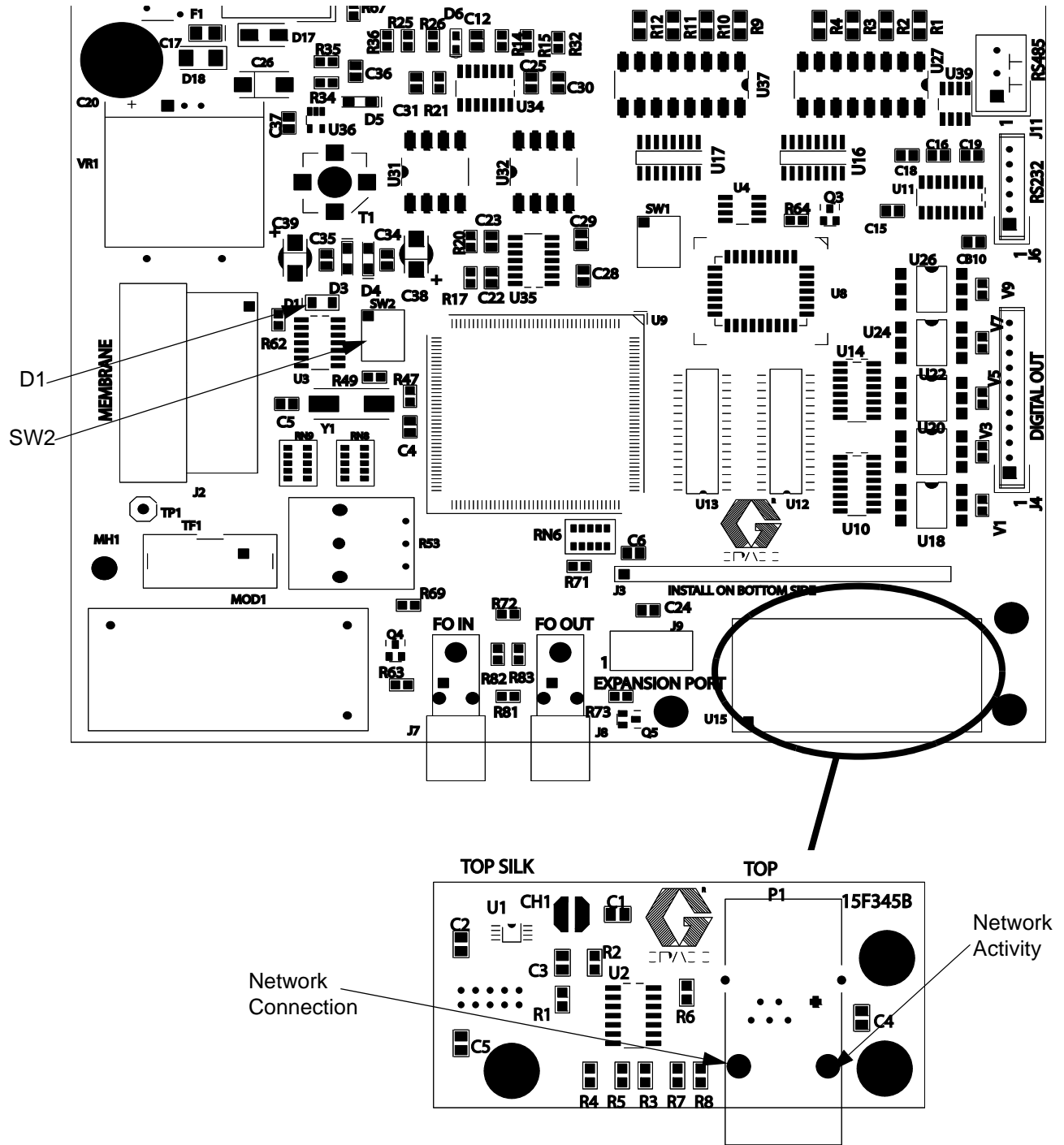





FIG. 10: Part Numbers 249306 and 249183

Service

Before Servicing

						
<ul style="list-style-type: none"> • To avoid electric shock, turn off EasyKey™ power before servicing. • Servicing EasyKey™ display exposes you to high voltage. Shut off power at main circuit breaker before opening enclosure. • All electrical wiring must be done by a qualified electrician and comply with all local codes and regulations. • Do not substitute system components as this may impair intrinsic safety. 						

After Servicing

After servicing the system, be sure to follow the **Start Up** checklist and procedure in the ProMix™ Auto Operation manual.

1. Follow “Pressure Relief Procedure” on page 10.
2. Follow “Shutdown” on page 11 if service time may exceed pot life time and before servicing fluid components.
3. Close main air shutoff valve on air supply line and on ProMix™ Auto.
4. Shut off ProMix™ Auto power (0 position). FIG. 11.
5. If servicing EasyKey™ Display, also shut off power at main circuit breaker.

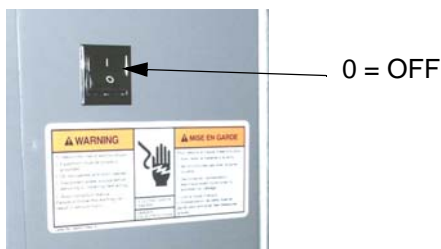



FIG. 11

Replacing Air Filter Element

NOTE: There are three air filter elements: two on the Solenoid Air Supply Control (part no. 570122) and one on the Wall Mount Fluid Panel.

						
Removing a pressurized air filter bowl could cause serious injury. Depressurize air line before servicing.						

Check the 5 micron air manifold filter daily and replace element (part no. 15D909) as needed.

1. Close main air shutoff valve on air supply line and on unit. Depressurize air line.
2. Remove filter cover (A).

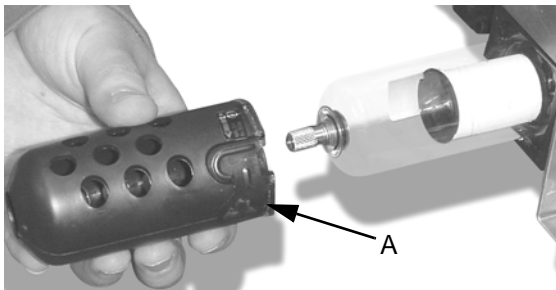

FIG. 12

3. Unscrew filter bowl (B).



FIG. 13

4. Remove and replace element (C).

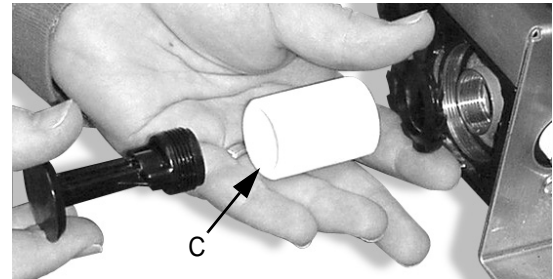

FIG. 14

5. Screw filter bowl (B) on securely. Install cover (A).

EasyKey™ Display

- [Updating Software](#)
- [Replacing Power Supply Board](#)
- [Replacing Power Supply Fuses](#)

 **NOTE:** If you need to replace the EasyKey™ display board, display backlight, or keypad, replace with Display Kit 253025.

CAUTION

To avoid damaging circuit board when servicing, wear grounding strap on wrist and ground appropriately.

Updating Software

There are 2 ways to update software:

- Programmed software chip 249943 or Kit 249989. Kit includes display board software chip, chip extractor tool, and grounding wrist strap.
- Follow **Installing New Software Chip** procedure.

Installing New Software Chip

1. Follow [Before Servicing](#) procedure, page 18.
2. Unlock and open EasyKey™ door with its key.
3. Remove display board chip (C - FIG. 15) with removal tool.
 - a. Press removal tool into flash chip socket open holes.
 - b. Squeeze the tool to grip the chip and carefully pull it straight out of the socket.

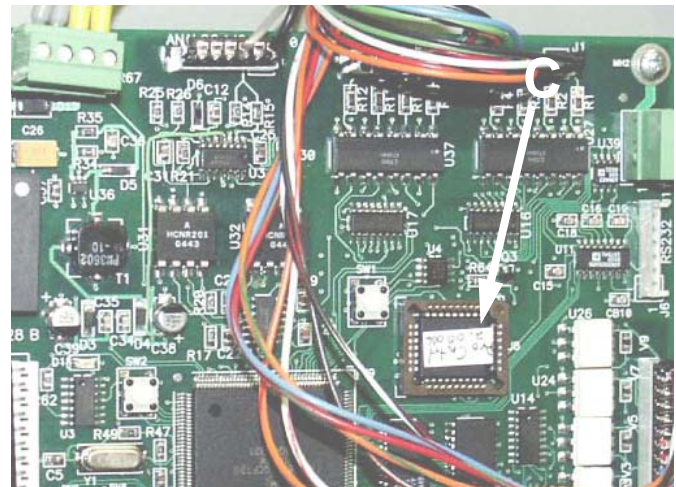

FIG. 15

4. Align beveled corner of new chip with beveled corner of socket and press chip into place. Make sure the pins are not bent or touching.
5. Close and lock EasyKey™ door with key.
6. Turn EasyKey™ power on to test circuit boards.

Replacing Power Supply Board

--	--	--	--	--	--	--

Servicing the power supply board exposes you to high voltage. To avoid electric shock, turn off EasyKey™ power and shut off power at main circuit breaker before servicing.

1. Follow **Before Servicing** procedure, page 18.
2. Unlock and open EasyKey™ door with its key.
3. Disconnect cables (G1, G2, G3). FIG. 16.
4. Remove 2 screws (H) and remove cover (J).
5. Noting their location, remove 5 screws (Y) from power supply board (521a). Remove board.
6. Apply thermal compound to the heatsink (Z) on the back of the new power supply board (521a).
7. Install the new power supply board with the 5 screws (Y).
8. Install cover (J) with 2 screws (H).
9. Connect cables (G1, G2, G3).
10. Close and lock EasyKey™ door with key.

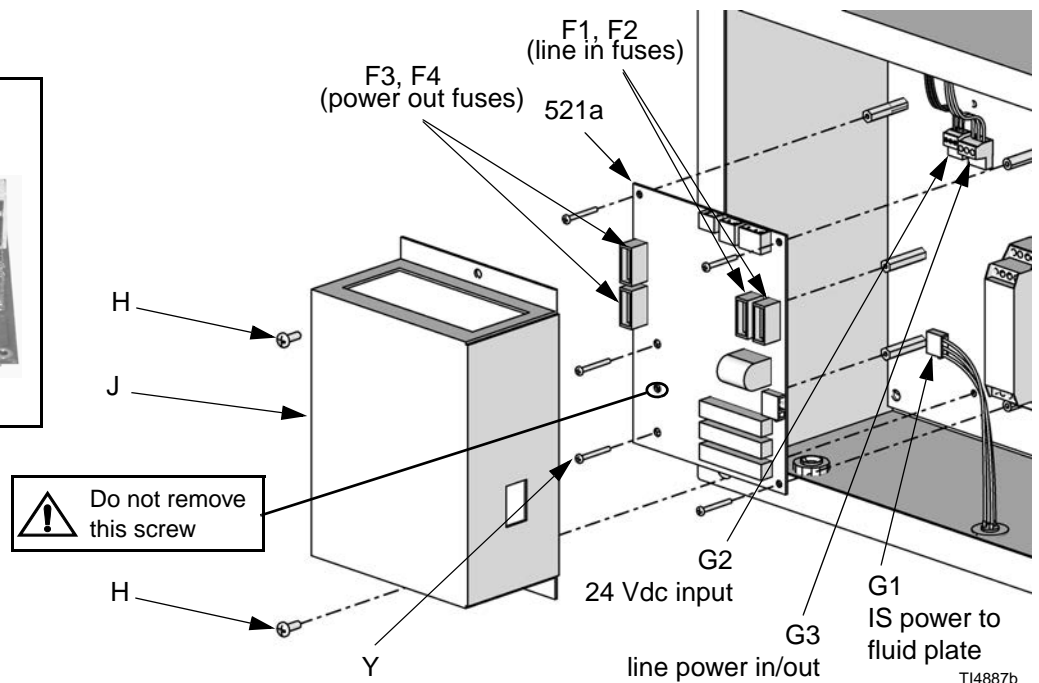
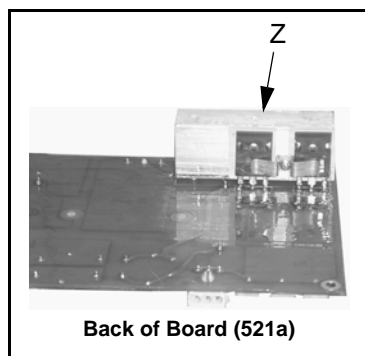

FIG. 16

11. Turn on power at main circuit breaker.
12. Turn EasyKey™ power on to test operation.

Replacing Power Supply Fuses

--	--	--	--	--	--	--

Servicing the power supply board exposes you to high voltage. To avoid electric shock, turn off EasyKey™ power and shut off power at main circuit breaker before servicing.

Fuse	Part No.	Description
F1, F2	114788	2 amp, time lag
F3, F4	15D979	.4 amp, quick acting

1. Follow **Replacing Power Supply Board**, steps 1-4.
2. Remove the fuse (F1, F2, F3, or F4) from its fuse holder. FIG. 16.
3. Snap new fuse into holder.
4. Follow **Replacing Power Supply Board**, steps 8-12.

Smart Fluid Panels

- Preparation
- Replacing Control Board
- Replacing Solenoids
- Reassemble Fluid Panel

Preparation

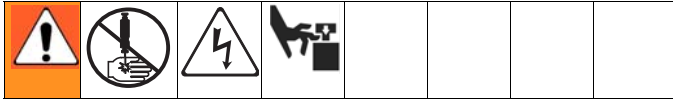

1. Follow "Pressure Relief Procedure" on page 10 and "Shutdown" on page 11.
2. Close main air shutoff valve on air supply line and on ProMix™ Auto.
3. Relieve air pressure in system by decreasing air pressure to 0 via the Air Supply Control.
4. Shut off ProMix™ Auto power (0 position). FIG. 17.

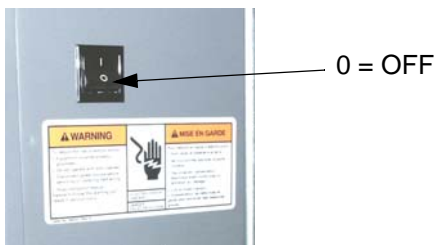
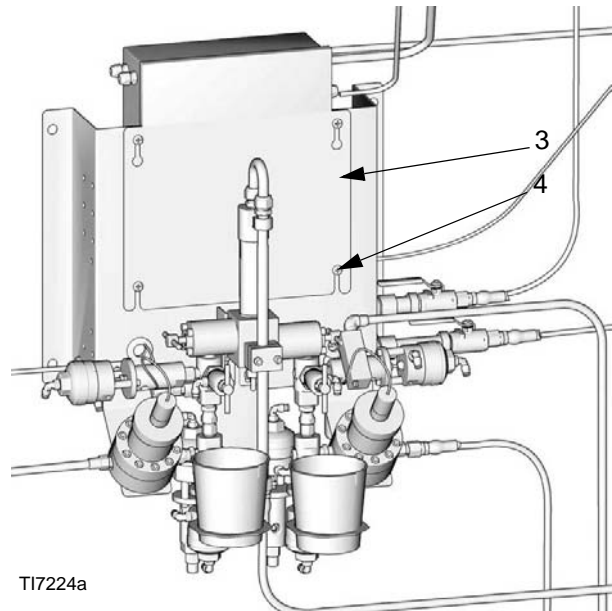

FIG. 17

5. Wall Mount Fluid Panel: Loosen the 4 screws (4), then remove the cover (3). FIG. 18.

RoboMix Fluid Panel: Loosen the 4 screws (4), then remove the cover (3). FIG. 19.



TI7224a

FIG. 18

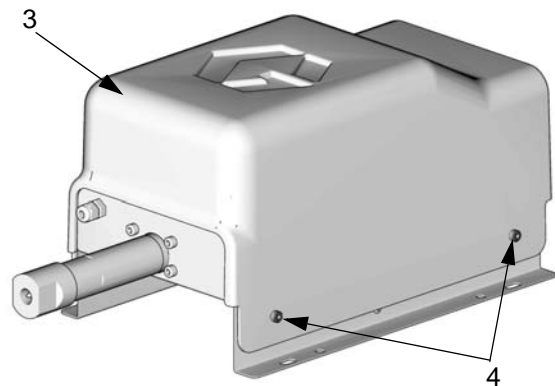

FIG. 19

Replacing Control Board

CAUTION

To avoid damaging circuit board when servicing, wear grounding strap on wrist and ground appropriately.

1. Follow [Preparation](#) procedure, page 22.
2. Loosen 6 screws (5) on bottom of panel to remove control board cover (6). FIG. 20 (RoboMix Fluid Panel only.)

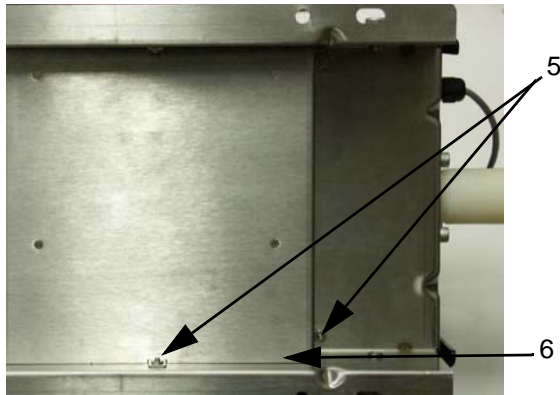

FIG. 20

3. Disconnect fiber optic wires and all cables (J1, J3, J4, J5, J6, J9, J10) from control board (706). FIG. 21.

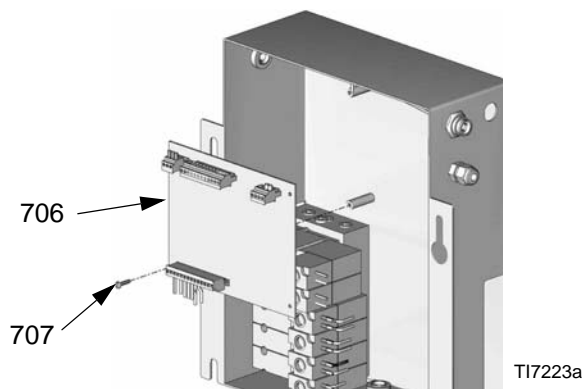

FIG. 21

4. Remove 4 screws (707). Remove control board (706). FIG. 21. (RoboMix Fluid Panel not shown; use same procedure.)
5. Install new control board (706) with 4 screws (707).
6. Connect cables to control board (706). FIG. 23. Insert fiber optic cable connectors (J4, J6) into board connectors (E), matching blue with blue,

black with black, and hand-tighten connectors (E). FIG. 23 and FIG. 23.

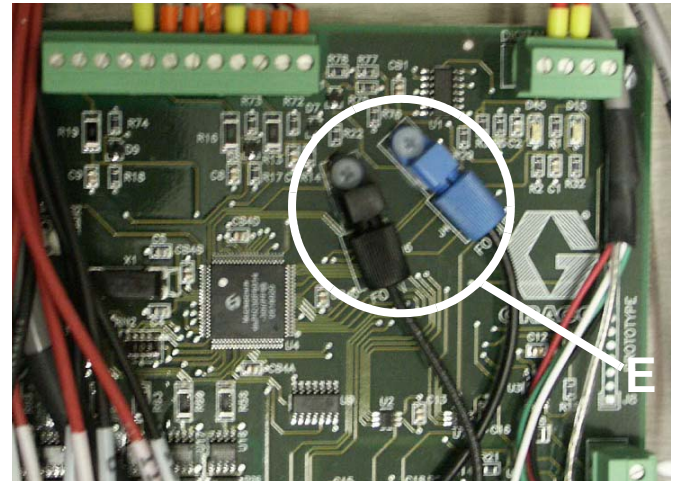

FIG. 22: RoboMix Fluid Panel Circuit Board

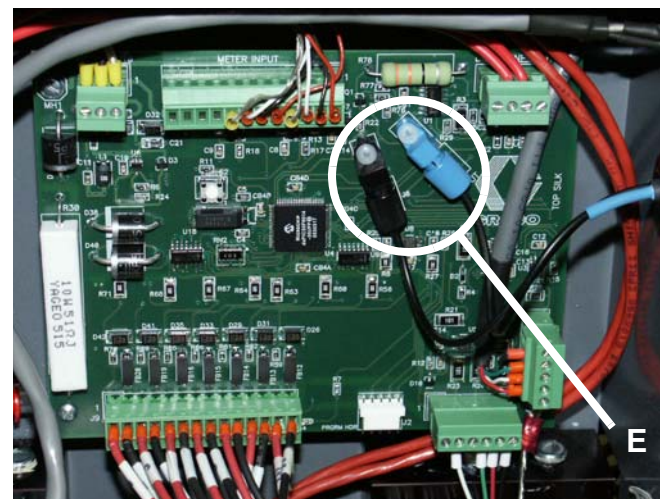

FIG. 23: Wall Mount Fluid Panel Circuit Board

7. Reassemble control board cover with 6 screws (5). FIG. 20. (RoboMix Fluid Panel only.)
8. [Reassemble Fluid Panel](#) (page 24).
9. Turn EasyKey™ power on to test operation.

Replacing Solenoids

The Fluid Panel has a minimum of 4 solenoids. If you have a color change valve option installed, you have additional (optional) solenoids for each color dump valve and dump valve and catalyst dump valve. Refer to [Pneumatic Diagram](#), page 28.

To replace a single solenoid.

1. Follow **Preparation** procedure, page 22, and shut off power at main circuit breaker.
2. Disconnect 2 solenoid wires (N) from control board (2). FIG. 24 and FIG. 25 (wires not shown in FIG. 25).
3. Unscrew 2 screws (P) and remove the solenoid.

Solenoid	Actuates
<i>Standard</i>	
1	Dispense Valve A
2	Dispense Valve B
3	Air Purge Valve A
4	Solvent Purge Valve B
<i>Optional</i>	
5	Dump A Valve
6	Dump B Valve
7	Third Purge Valve (Wall Mount Fluid Panel only.) See manual 311395.

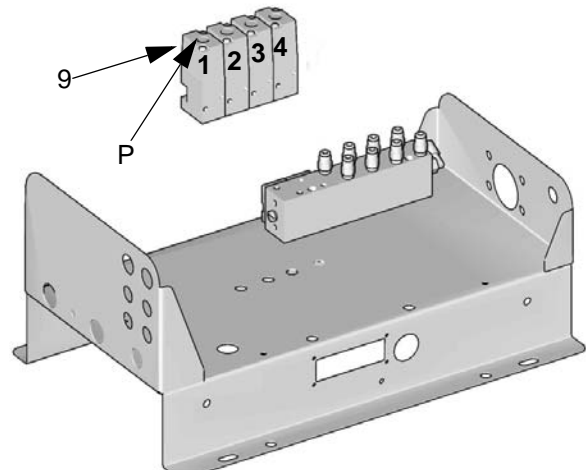
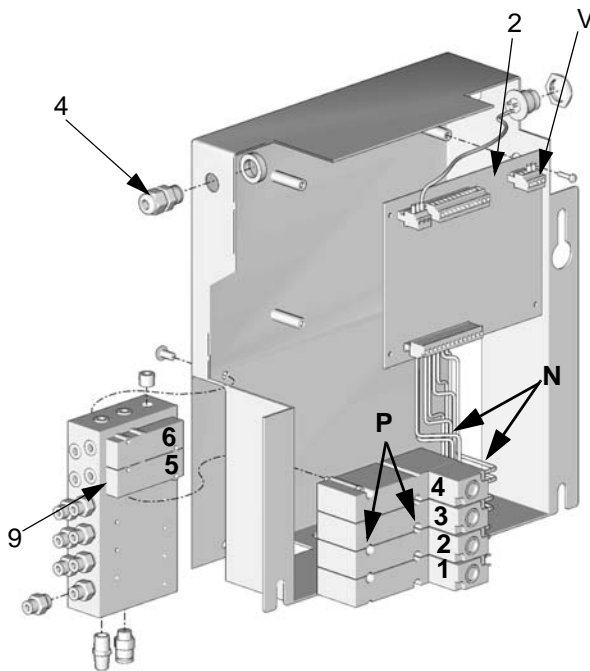

FIG. 25: RoboMix Fluid Panel Solenoids

4. Install new solenoid (9).
5. Connect 2 wires (N) to control board (2). Solenoid wires are polarized (red +, black -). Refer to **ProMix™ Auto Electrical Schematic**, page 29.
6. Reassemble control board cover.

Reassemble Fluid Panel

1. Slide the cover (3) back into place.
2. Secure the cover (3) and panel with the 4 screws (4). FIG. 26 and FIG. 19.



T17157e

FIG. 24: Wall Mount Fluid Panel Solenoids

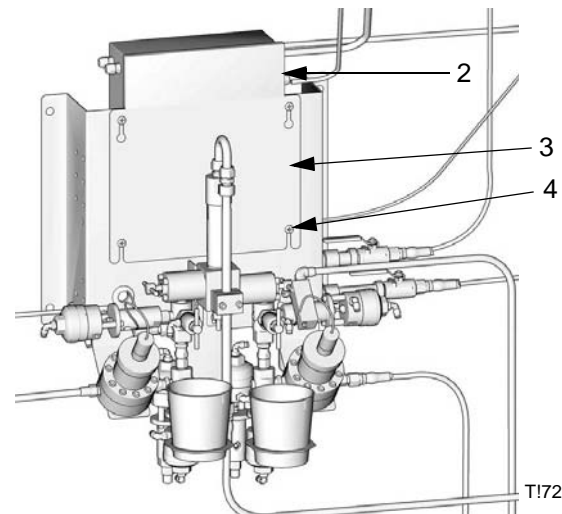

T17224a

FIG. 26

Servicing Flow Meters

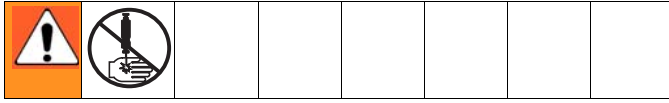

- **Coriolis Meter:** To remove and service see Coriolis meter manuals. To service, see manual 310696.
- **G250 or G250HR Meter:** To remove, follow procedure below. To service, see manual 308778.
- **G3000 or G3000HR Meter:** To remove, follow procedure below. To service, see manual 308778.

G250/G3000 or G250HR/G3000HR Meter

Removing

1. Follow [Pressure Relief Procedure](#), page 10.
2. Close main air shutoff valve on air supply line and on ProMix™ Auto.
3. Shut off ProMix™ Auto power (0 position).
4. Unscrew cable connector (110) from meter (1). FIG. 28.

 **NOTE: The meter shield (R) is unattached and may fall off when you remove the meter (1). FIG. 28.**

5. Unscrew M6 screws (107) from bottom of meter mounting plate (108) with socket wrench. FIG. 27.
6. Unscrew fluid line from meter inlet (P).
7. Unscrew meter (1) from dispense valve connector (H). FIG. 28.
8. Service meter as instructed in the meter manual.

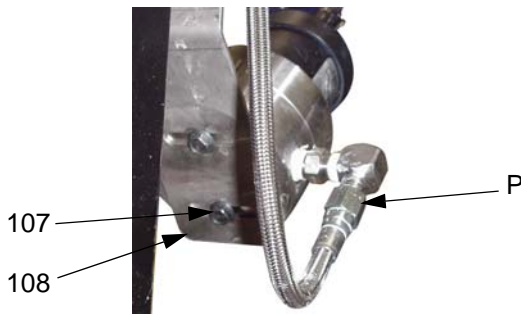

FIG. 27

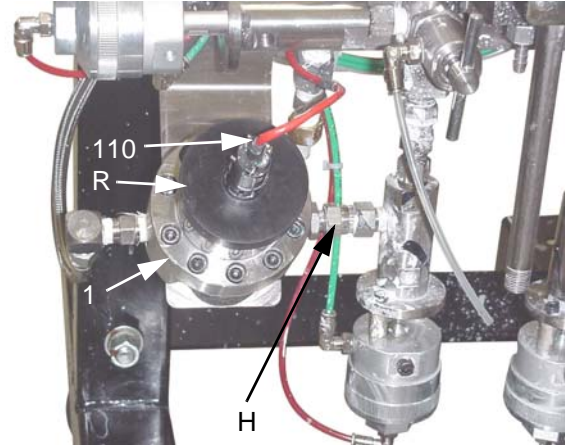

FIG. 28

Installing

9. Screw meter (1) securely onto the dispense valve connector (H), using a wrench.

CAUTION

To avoid leakage, secure the meter (1) to the dispense valve connector (H) before connecting it to the plate (108).

10. Secure meter (1) to plate (108) with screws (107).
11. Connect meter cable (110). See FIG. 29.
12. Connect fluid line (P).
13. Calibrate meter as instructed in ProMix™ Auto Operation manual.

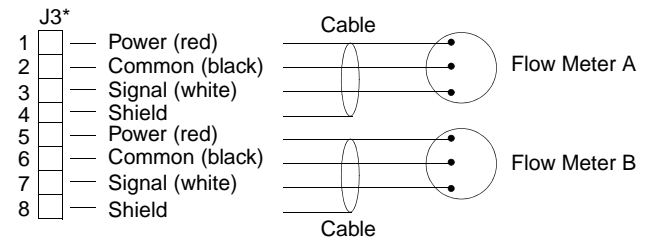

*Connector on Fluid Panel circuit board

FIG. 29: G250 or G250HR Cable Schematic
Same for G3000/3000HR

Servicing Fluid Manifold

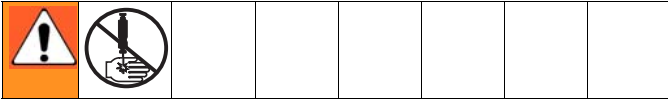

 **NOTE:** There are two different size integrators: 50cc and 25cc. 25cc is etched on the outside of the 25cc integrator component.

Removing

1. Follow [Servicing Flow Meters](#) procedure, steps 1-7, page 25.
2. Disconnect air and fluid lines from the manifold (5).
3. Remove 4 screws (34). To ease screw removal, use a long T-handle Allen wrench.
4. Remove A and B meter bracket screws.
5. Remove the 3 screws behind the fluid manifold.
6. Remove fluid manifold (5).
7. Service fluid manifold as instructed in the Fluid Mix Manifold manual.

Installing

1. Install the 3 screws behind the fluid manifold.
2. Secure fluid manifold (5) and mounting plate (35) with 4 screws (34).
3. Install A and B meter (1) bracket screws. See steps 9-11, Installing, Page 24.
4. Connect air and fluid lines.

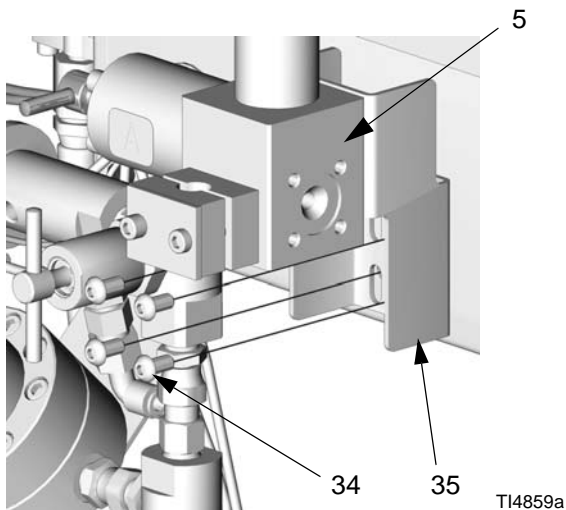
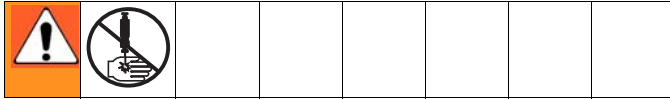

FIG. 30

Servicing Color Change/Catalyst Assembly



Removing Color Change Pneumatic Solenoid

1. Follow "Pressure Relief Procedure" on page 10.
2. Close main air shutoff valve on air supply line and on ProMix™ Auto.
3. Shut off ProMix™ Auto power (0 position).
4. Remove cover (A) by removing screws (B) and loosening screws (C not shown).
5. Remove 4 screws on solenoid to replace solenoid.

Removing Color/Catalyst Change Fluid Valve(s)

1. Disconnect air (FF) and fluid lines (CC and GG) from color change fluid valves.

 **NOTE: Before disconnecting, verify that air and fluid lines are clearly labeled to ease reassembly.**

2. Service color change valves as instructed in the following manuals:

Manual	Description
307731	Color Change Valve Assembly, low pressure
307941	Color Change Valve, low pressure
308977	Color Change Valve Assembly, high pressure
308291	Color Change Valve, high pressure
310656	Color Change Kit

Installing

1. Connect air and fluid lines.

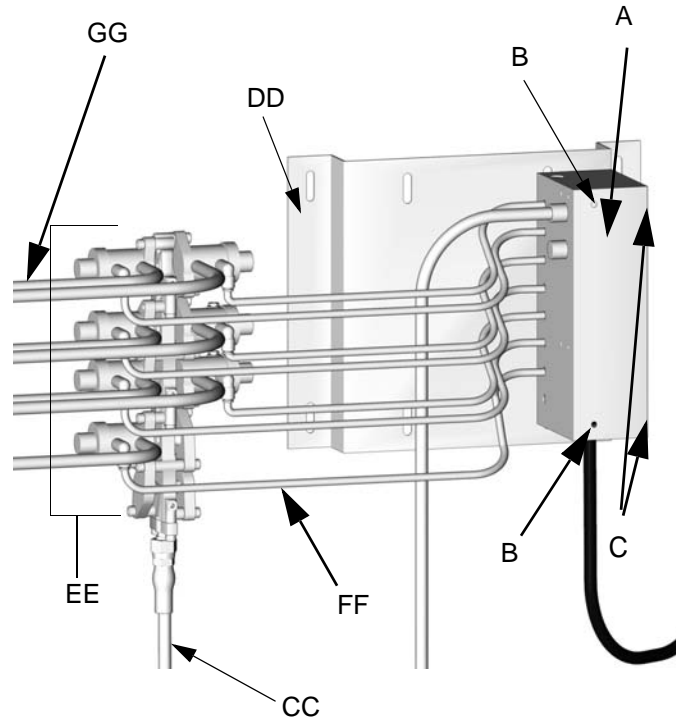

Low Pressure Color Change

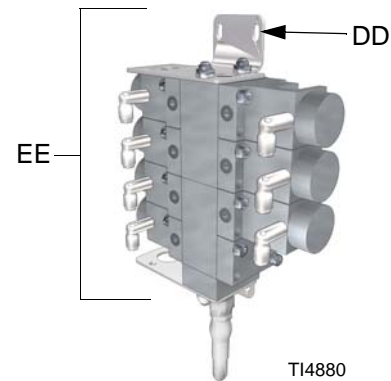

High Pressure Color Change

FIG. 31

ProMix™ Auto Electrical Schematic

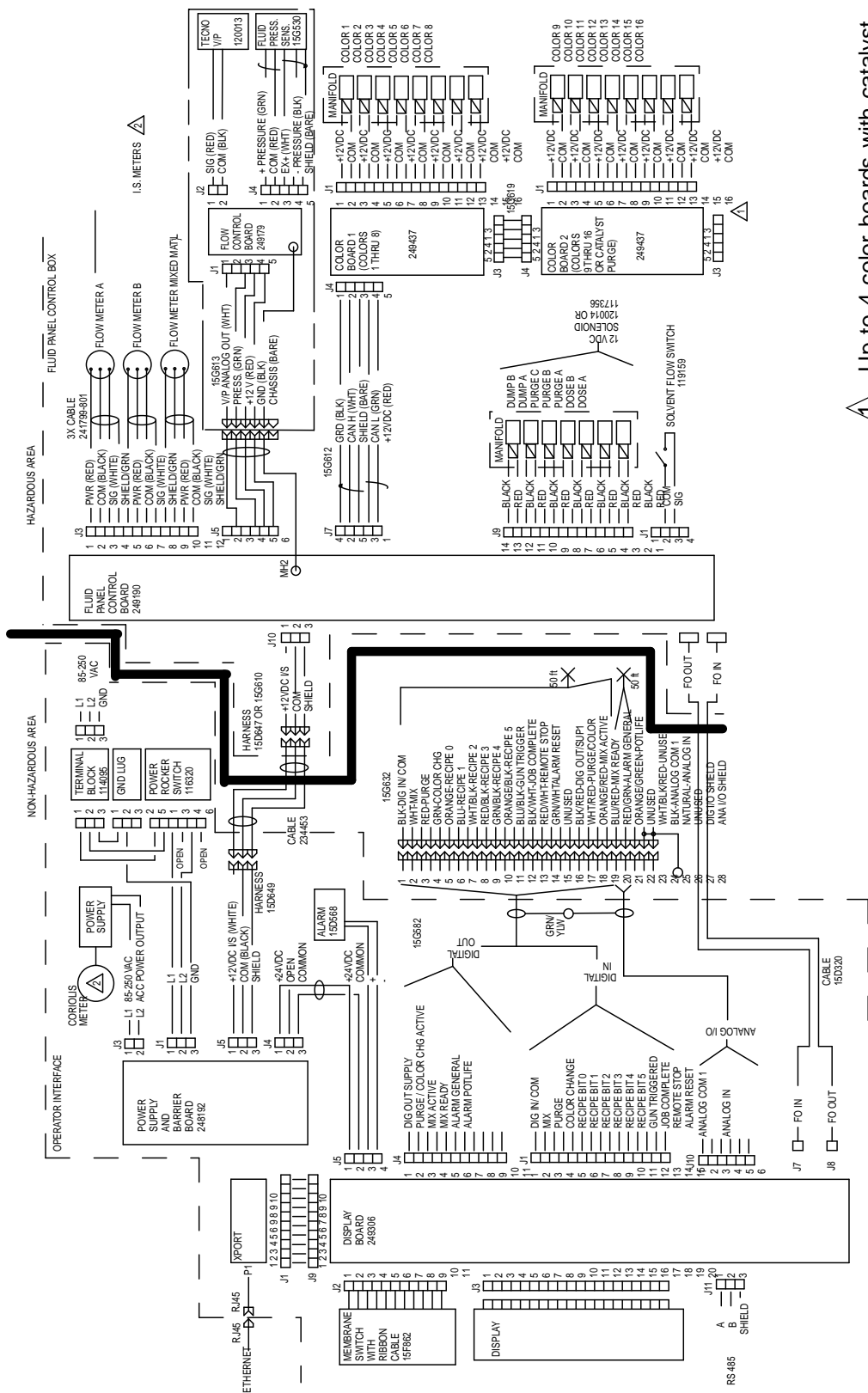

▲ Up to 4 color boards with catalyst purge.

Do not install equipment approved for only non-hazardous locations in a hazardous area. Substitution of components may impair intrinsic safety.

FIG. 33

Parts

ProMix™ Auto Wall Mount Assembly

Standard ProMix™ Auto Wall Mount Assembly		
Ref.	Part No.	Description
A	part of mix manifold 248251; see page 34	A side (resin) dispense valve
B	part of mix manifold 248251; see page 34	B side (catalyst) dispense valve
C	part of mix manifold 248251; see page 34	A side (resin) dump valve
D	part of mix manifold 248251; see page 34	B side (catalyst) dump valve
E	see table at right	Flow Meter A
F	see table at right	Flow Meter B
G	see page 33	Wall mount fluid panel
H	249964; see page 42	EasyKey display
J	see page 45	Color change control
K	see table at right	Color change kits
L	see page 45	Catalyst change control
M	see table at right	Catalyst change kits
N	249849; see page 44	Flow control regulator
P	570122	Air supply control
R	15G612	Color change network cable, 50 ft.
S	15G619	Color change network cable, 3 ft.
T	15G711	IS power cable, 100 ft
U	15G710	F/O cable, 100 ft
V	15G611	Flow control cable, 10 ft.
W	15G869	Ethernet cable, 6 ft.
X	15G632	Discrete I/O cable

ProMix™ Auto Wall Mount Fluid Panel Component Options Table				
Ref. No.	Option	Part No.	Description	Qty.
F Flow Meter B Kit				
	0		None	0
	1	234564	G3000; page 36	1
	2	234566	G3000HR; page 36	1
	3	234563	Coriolis; see manual 310696	1

Color Change Options Table	
Part No.	Description
249973	Wall Panel Color Change Kit for 2 colors
249974	Wall Panel Color Change Kit for 4 colors
249975	Wall Panel Color Change Kit for 7 colors
249976	16-23 & 24-30 Color Change Kits

ProMix™ Auto Wall Mount Fluid Panel Component Options Table				
Ref. No.	Option	Part No.	Description	Qty.
E Flow Meter A Kit				
	0		None	0
	1	234564	G3000; page 36	1
	2	234566	G3000HR; page 36	1
	3	234563	Coriolis; see manual 310696	1

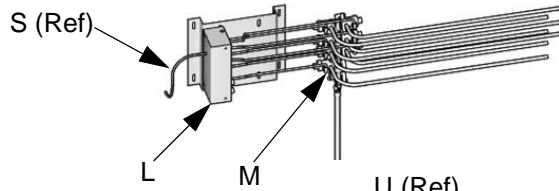
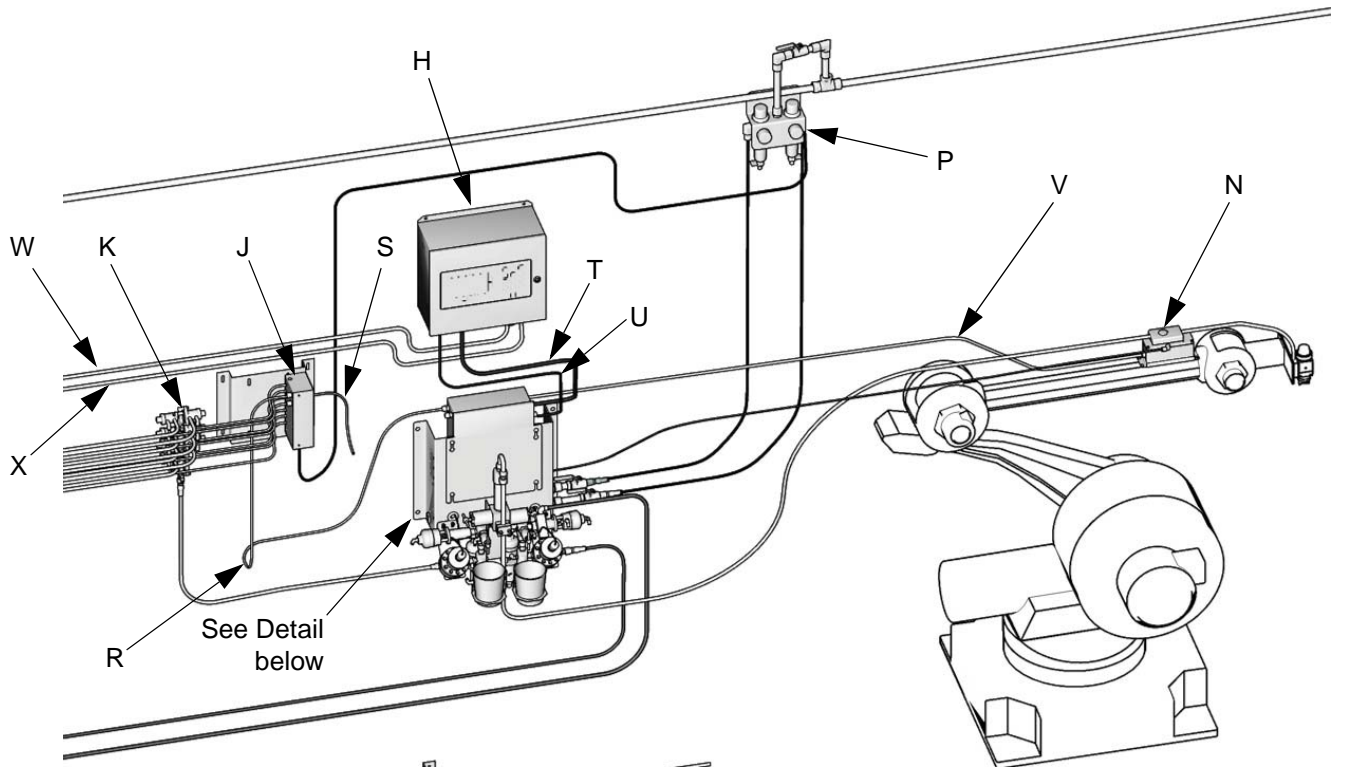

U (Ref) T (Ref)

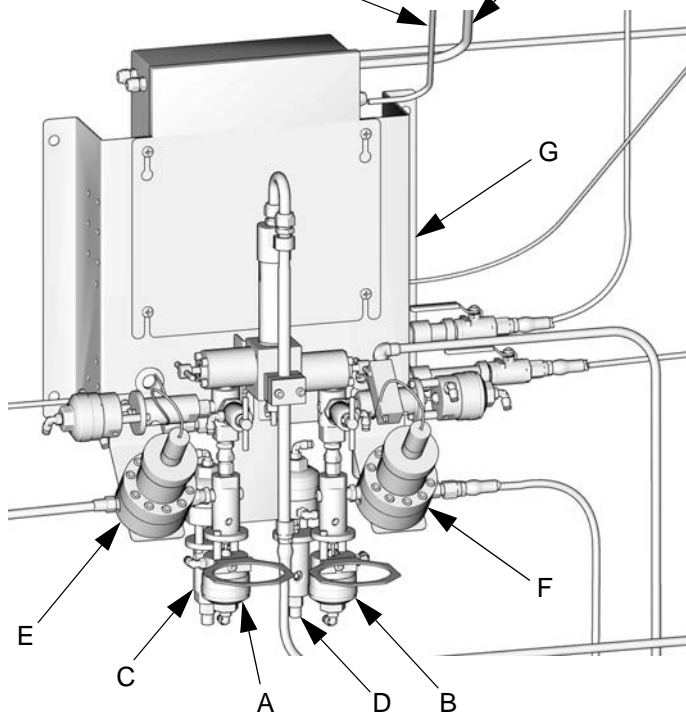

TI6802B

TI7281A

ProMix™ Auto RoboMix II Assembly

ProMix™ Auto RoboMix II Assembly		
Ref.	Part No.	Description
A	part of RoboMix II; see page 38	A side (resin) supply port
B	part of RoboMix II; see page 38	B side (catalyst) supply port
C	part of RoboMix II; see page 38	A side (resin) dump port
D	part of RoboMix II; see page 38	B side (catalyst) dump port
E	part of RoboMix II; see page 38 and table at right	Flow Meter A
F	part of RoboMix II; see page 38 and table at right	Flow Meter B
G	see page 38	RoboMix II
H	249964; see page 42	EasyKey display
J	see page 45	Color change control
K	see table at right	Color change kits
L	see page 45	Catalyst change control
M	see table at right	Catalyst change kits
N	249849; see page 44	Flow control regulator
P	570122	Air supply control
R	15G612	Color change network cable, 50 ft.
S	15G619	Color change network cable, 3 ft.
T	15G711	IS power cable, 100 ft
U	15G710	F/O cable, 100 ft
V	15G611	Flow control cable, 10 ft.
W	15G869	Ethernet cable, 6 ft.
X	15G632	Discrete I/O cable

ProMix™ Auto RoboMix II Component Options Table				
Ref. No.	Option	Part No.	Description	Qty.
F		Flow Meter B Kit		
	0		None	0
	1	249426	G3000 (not shown); see manual 308778	1
	2	249427	G3000HR (not shown); see manual 308778	1
	3	234563	Coriolis (not shown); see manual 310696	1

Color Change Options Table	
Part No.	Description
249970	RoboMix II Color Change Kit for 2 colors
249971	RoboMix II Color Change Kit for 4 colors
249972	RoboMix II Color Change Kit for 7 colors

ProMix™ Auto RoboMix II Component Options Table				
Ref. No.	Option	Part No.	Description	Qty.
E		Flow Meter A Kit		
	0		None	0
	1	249426	G250 (see item 10 on page 38); see manual 308778	1
	2	249427	G250HR (not shown); see manual 308778	1
	3	234563	Coriolis (not shown); see manual 310696	1

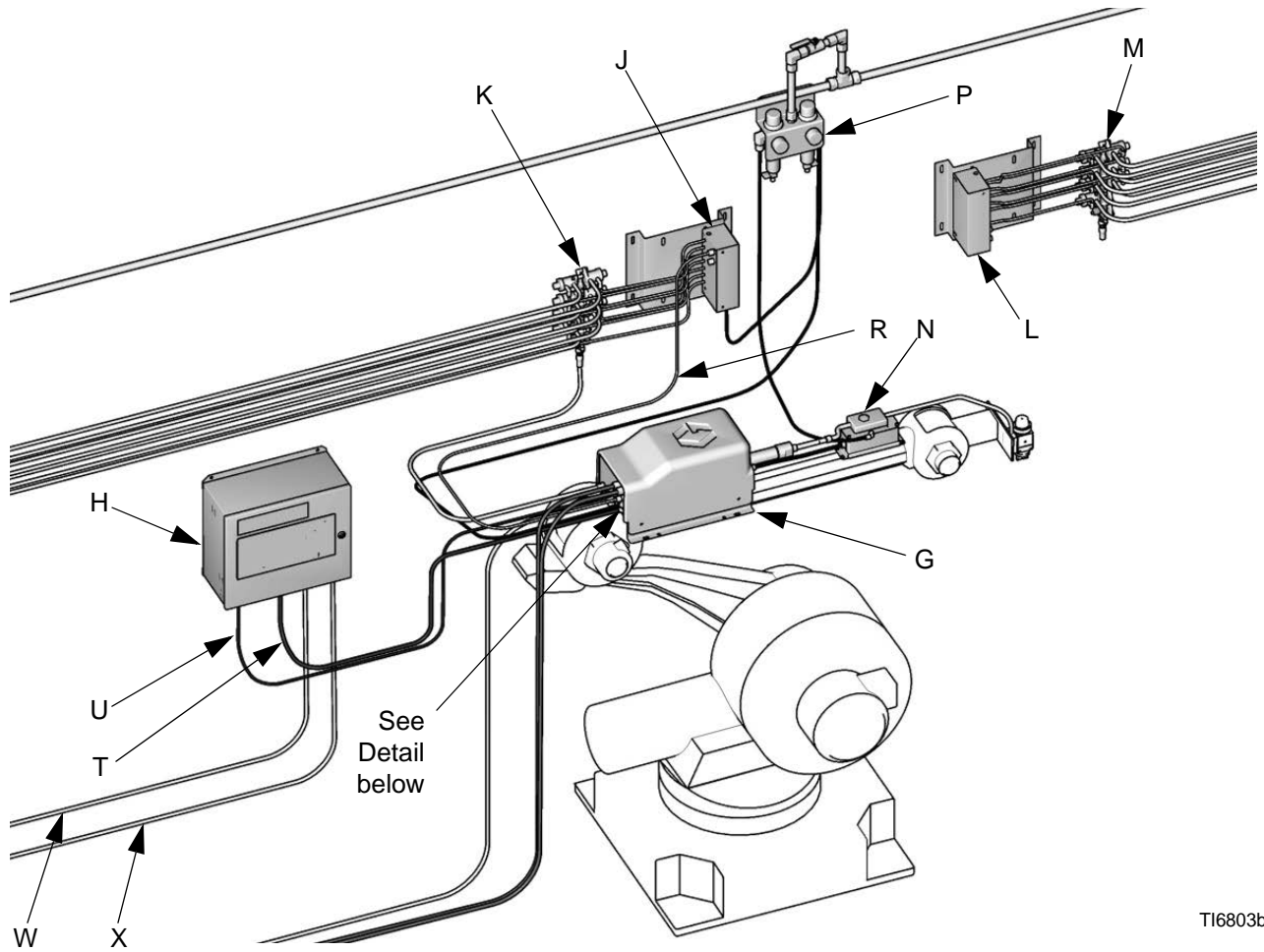

T16803b

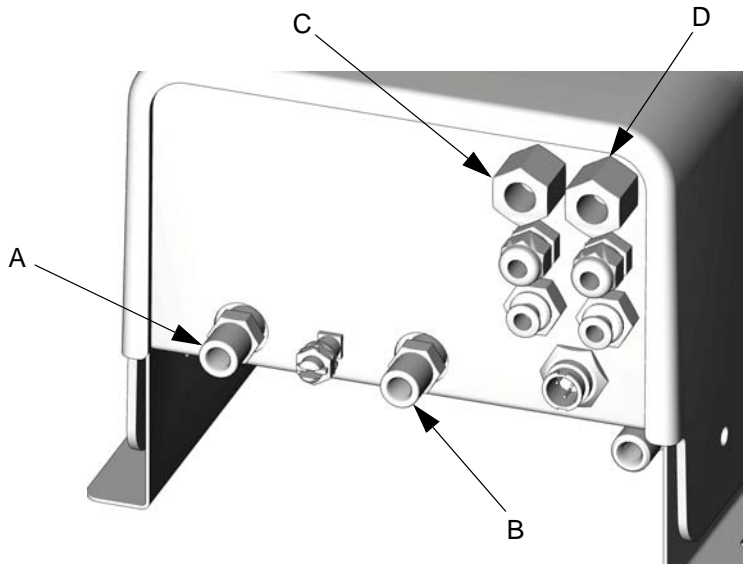

T16809a

Wall Mount Fluid Panel

See table for part number

Ref. No.	Part No.	Description	Qty.	Ref. No.	Part No.	Description	Qty.
1	280511	CONTROL, junction box; page 37	1	22†	15D320	CABLE, fiber optic	1
2	15D244	PLATE, mounting, manifold	1	23★	15G443	BRACKET, valve mount	-
3	15D247	COVER, enclosure	1	24★	287394	VALVE, dispense	-
4	113783	SCREW, mach, PNH	4	25	15G534	LABEL, identification	1
5	248251	MANIFOLD, mix, plural component; manual 310654	1	26		CONNECTOR, plug, 4 position	1
6	112925	SCREW, cap, BTNHD	4	27★		CONNECTOR, plug, 6 position	-
7	114124	FILTER, air, 3/8 NPT	1	28★		CONNECOTR, plug, 5 position	-
8	119143	FITTING, "Y" air	1	29	15G764	LABEL, installation	1
9	101765	GROMMET	3	30▲†	290331	LABEL, warning	1
10	501867	VALVE, check	1	31	104029	CLAMP, GND, elec	1
11	120278	SWITCH, solvent flow; pressure rated 3000 psi (21 MPa, 207 bar)	1	32		WASHER, flat	1
12	510223	FITTING, elbow, male. 3/8 tube x 1/4 NPT	1	33†	186620	LABEL	1
14★	111987	CONNECTOR, cord, strain relief	-	34	104641	FITTING, bulkhead	1
15★	117356	VALVE, solenoid, 4-way manifold MT, 12 VDC (IS)	-	35	15E058	FITTING, push tube	1
16★†	15G611	CABLE, flow control	-	36†		TUBE, nylon, green, 5/32 D.D.	-
17★	114263	FITTING, connector, male, 1/8 NPT	-	37†		TUBE, nylon, red, 5/32 D.D.	-
18★†	100139	PLUG, pipe, headless	-	38		FITTING, reducer, plug-in	1
19★	114342	ELBOW, 1/4-18 NPSM	-	39†		TUBE, nylon, 1/4 D.D.	-
20★	205324	HOSE, coupled, 1 ft.	-				
21★	C19798	SCREW, cap, socket head	-				

▲ Replacement Warning labels, tags, cards are available at no cost.

★ Refer to table for quantity and assembly number.

† Not shown.

Assembly	Description	Reference Number and Quantity											
		14	15	16	17	18	19	20	21	23	24	27	28
249652	Basic	-	-	-	-	-	-	-	-	-	-	-	-
249654	Color Change	1	1	-	2	1	1	1	1	1	1	-	1
249655	Color and Catalyst Change	1	2	-	4	1	2	2	2	1	2	-	1
249656	Flow Control	1	-	1	-	1	-	-	-	-	-	1	-
249657	Flow Control and Color Change	2	1	1	2	1	1	1	1	1	1	1	1
249664	Flow Control, Color and Catalyst Change	2	2	1	4	1	5	2	5	1	5	1	1

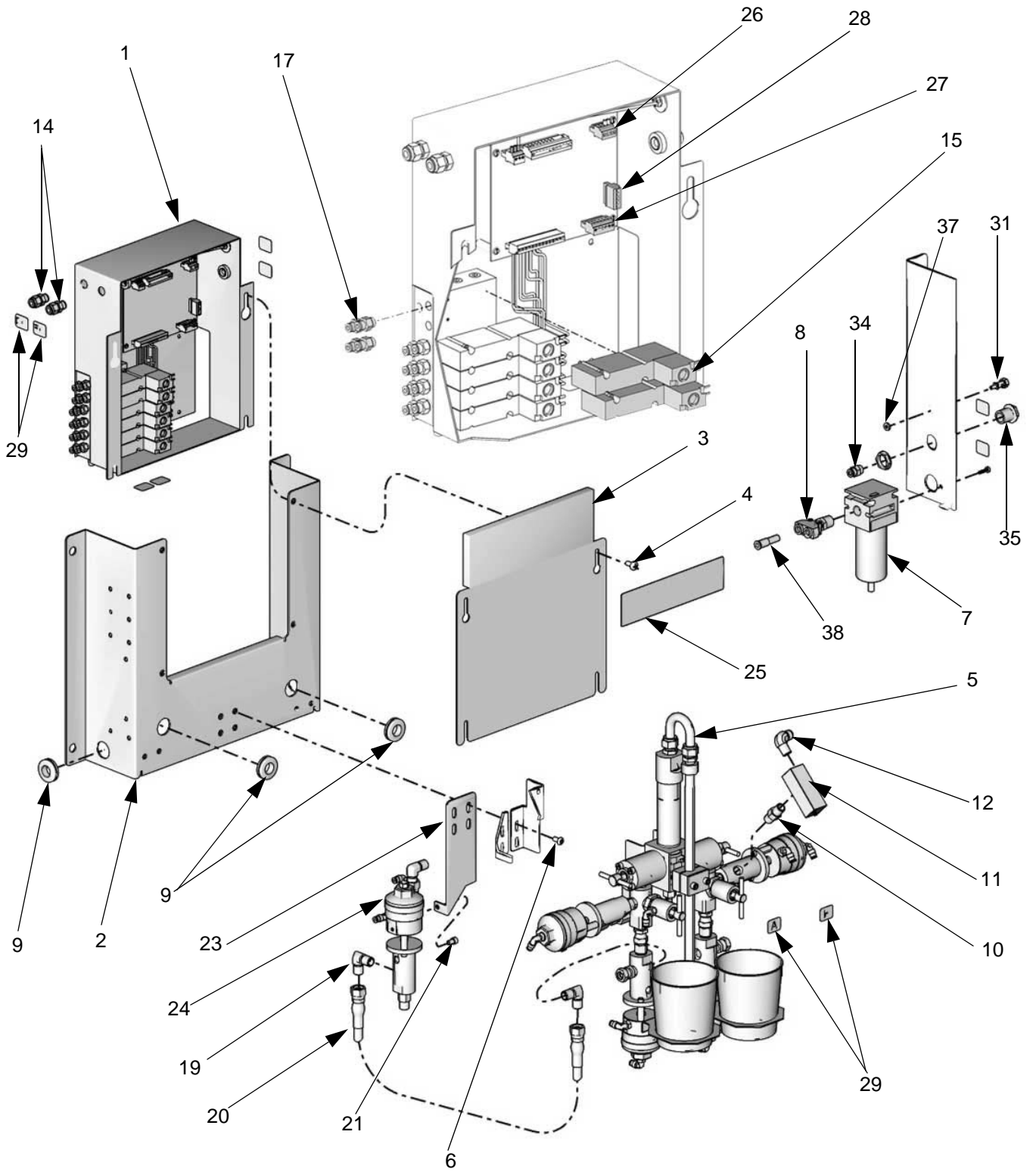

Flow Meter Kits

Part No. 234564, G3000

Part No. 234566, G3000HR

Ref. No.	Part No.	Description	Qty
1	239716	G3000 Flow Meter, 234564 only; see manual 308778	1
	244292	G3000HR Flow Meter, 234566 only; see manual 308778	1
2	195283	Shield	1
4	166846	Adapter, 1/4 npt x 1/4 npsm	1
5	114339	Swivel Union; 1/4 npt x 1/4 npsm	1
6	501867	Check Valve; 1/4-18 npt	1
7	114182	Screw, machine; M6 x 16	2
8	15D248	Mounting Plate	1
9†	112925	Screw, cap; 1/4-20 UNC x .375 in.	2
10	234628	Cable Assembly; 42 ft. (12.8 m)	1

† Not shown

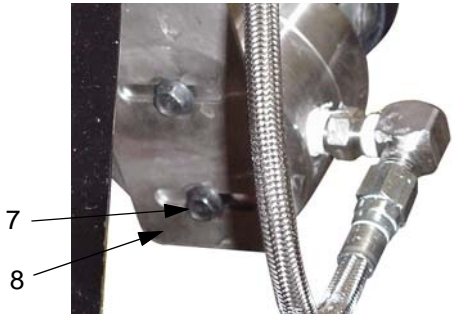
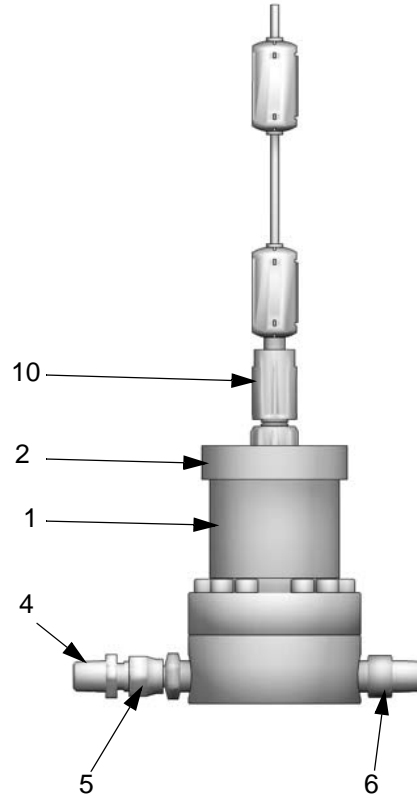

Control Junction Box

Part No. 280511

Ref. No.	Part No.	Description	Qty	Ref. No.	Part No.	Description	Qty
1		ENCLOSURE, solenoid	1	9	552183	PLATE, 400 series MAC	2
2	249190	BOARD, circuit assembly	1	10	100139	PLUG, pipe	7
3		SCREW, rd hd, 4-40 x .50	4	11	114263	FITTING, connector, male	8
4	111987	CONNECTOR, cord, strain relief	3	12		SCREW, mach, phillips	2
5	C06061	MUFFLER	2	13		HARNESS, connection	1
6		FITTING, connector, male	1	14	112512	FERRULE, wire, orange	8
7	117356	VALVE, solenoid, 12 VDC	4	16	120075	CONNECTOR, plug, 14 position	1
8	114230	MANIFOLD, solenoid	1	19†	15G762	LABEL, diagnostic	1

†Not shown.



TI7157a

RoboMix II (Replacement)

Part Numbers:

249827	Basic
249828	Flow Control
249829	Color Change
249830	Color and Catalyst Change
249831	Flow Control with Color Change
249832	Flow Control with Color Change and Catalyst Change

Ref. No.	Part No.	Description	Qty
1	287793	MANIFOLD, RoboMix basic mix; see page 41	1
2★	120014	VALVE, solenoid	-
3*		PACKING, o-ring, CV-75	2
4*	15G518	MIXER, integrator, tube 25CC	1
5*	15G519	CAP, mixer, integrator, 25CC	1
6*	15G520	HOUSING, integrator, 25CC	1
7*	15G521	CAP, integrator, 25CC	1
8		MANIFOLD, solenoid	1
9	C19798	SCREW, cap, socket head, 1/4-20 x .375	4
10	249427	METER, 250HR	2
11	108382	FITTING, seal, o-ring	1
12	120053	FITTING, elbow, tube	1
13		PANEL, RoboMix	1
14	15F917	COVER, panel	1
15★	120030	PLATE, blank, manifold, solenoid	-
16★	120029	FITTING, tube, bulkhead	-
17		PAN, drawer	1
18	15G525	SIGHT GLASS	1
19		GROMMET, electrical, 1 in.	1
21★		FASTNER, SHCS, 1/4-20 x 1.625	-
22†		SCREW, cap, SCH, M6 x 8	4
23		SCREW, mach, BDGH	6
24		WASHER, metallic	4
25	514619	NUT, acorn, 4-40 nylon	4
26		PLUG, button, LDPE	1
27	501867	VALVE, check	2
28	115223	FITTING, elbow, 3/8T x 1/4FNPT	2
29	166421	NIPPLE, pipe, 5/8 hex x 1-1/2, SST	2
30	104029	CLAMP, GND, elec	1
31	111307	WASHER, lock, external, 5 mm	1
32		NUT, hex	1
33		BULKHEAD, tube, 1/4 in.	2
34★	110932	CONNECTOR, tube, male, 10-32 x 5/32	-
35	249190	BOARD, circuit, control, assembly	1
36★†		PLUG, button, LDPE	-

Ref. No.	Part No.	Description	Qty
37★	111987	CONNECTOR, cord, strain relief	-
38★†		PLUG, button, LDPE	-
39★†	101970	PLUG, pipe, HDLS	-
40	114342	ELBOW, 1/4-18 NPSM	1
41★	692022	VALVE, diaphragm dispense, stainless wetted	-
42★	510223	FITTING, elbow, male	-
43★	513308	FITTING, connector	-
44		SCREW, mach, pan hd	4
45	15G610	HARNESS, connection	1
46	241800	CABLE, meter	2
47†	15D320	CABLE, fiber optic, twin	1
48★†	15G611	CABLE, flow control	-
49★†	15G612	CABLE, color change, 50 ft.	-
50†	949122	KIT, accessory, Y flexible	1
53†	117369	CONNECTOR, plug, 11 position	1
54†		CONNECTOR, plug, 4 position	1
55★†	119248	CONNECTOR, plug, 5 position	-
56★†	15G795	CONNECTOR, plug, 6 position	-
57†	15G796	CONNECTOR, plug, 14 position	1
58†		TUBE, PTFE, 3/8 O.D.	-
59†		TUBE, nylon, red, 5/32 O.D.	-
60†		TUBE, nylon, green, 5/32 O.D.	-
61†	15G762	LABEL, diagnostic	1
62†		TUBE, poly-flow, 1/4 O.D.	-

★Refer to table for quantity and corresponding RoboMix II assembly number.

†Not shown.

*Parts included in 25cc Accessory Integrator Kit 15G868 (purchase separately).

Assembly	Reference Number/Quantity															
	2	15	16	21	34	36	37	38	39	41	42	43	48	49	55	56
249827	4	2	1	2	8	2	1	2	2	-	-	2	-	-	-	-
249828	4	2	1	2	8	2	2	1	2	-	-	2	1	-	-	1
249829	5	1	2	4	10	1	3	-	1	1	1	4	-	1	1	-
249830	6	-	3	6	12	-	2	1	-	2	2	6	-	1	1	-
249831	5	1	2	4	10	1	3	-	1	1	1	4	1	1	1	1
249832	6	-	3	6	12	-	3	-	-	2	2	6	1	1	1	1

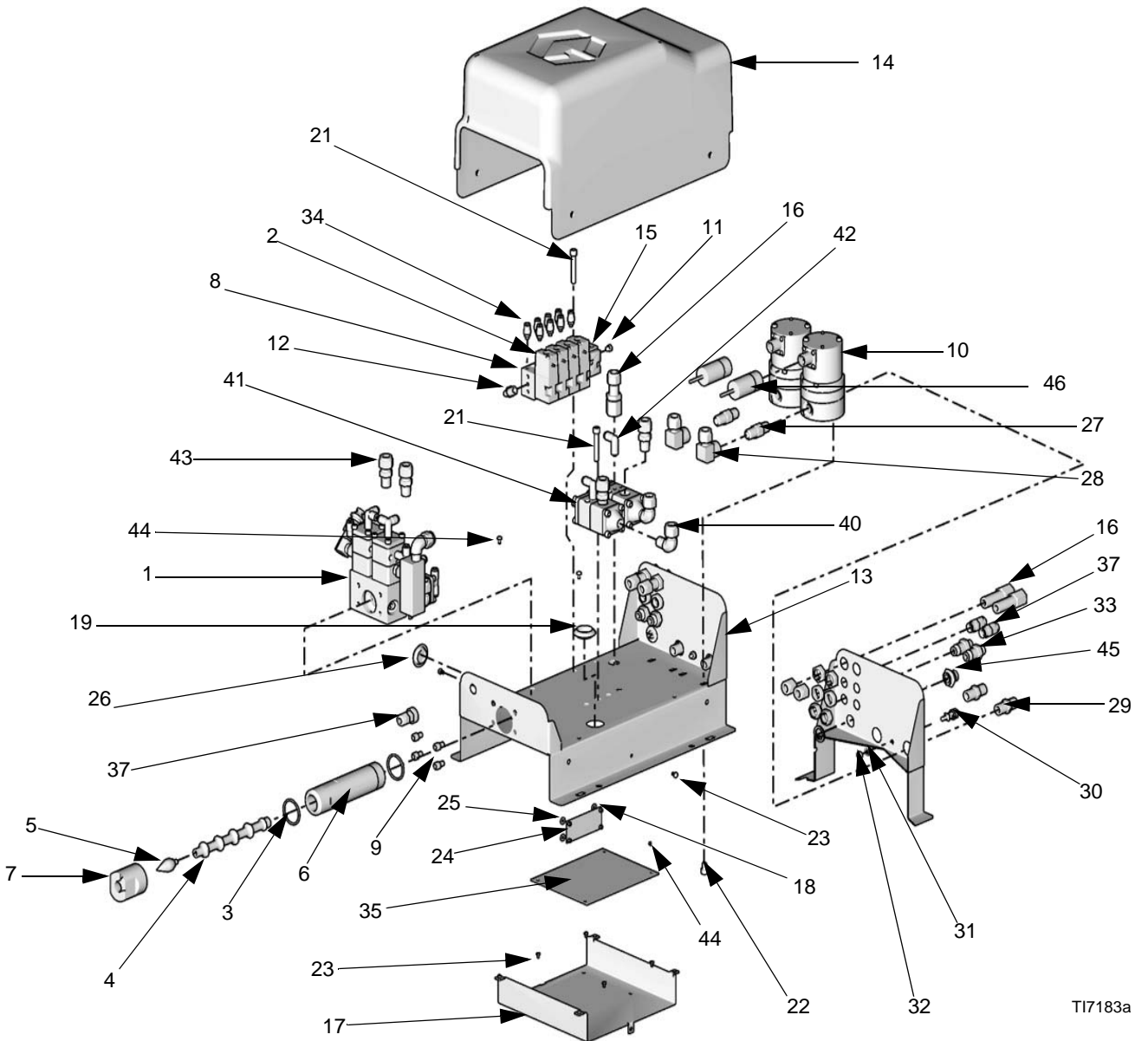

T17183a

RoboMix II Mix Manifold

Part No. 287793

Ref.	No.	Part No.	Description	Qty.
	2	101970	PLUG, pipe, HDLS	2
	4	504235	FITTING, tube, bulkhead, female	1
	5	116716	FITTING, elbow, 90 degree	1
	6	692068	VALVE, DDV surface mount	4
	7	119159	SWITCH, solvent	1
	8		MANIFOLD	1
	9*	501867	VALVE, check	2
	10	510223	FITTING, elbow, male	3
	11*	116768	PACKING, o-ring	4
	12	110932	CONNECTOR	2
	13*	110208	PLUG, pipe, HDLS	2

* Parts included in Service Kit 15G844 (purchase separately).

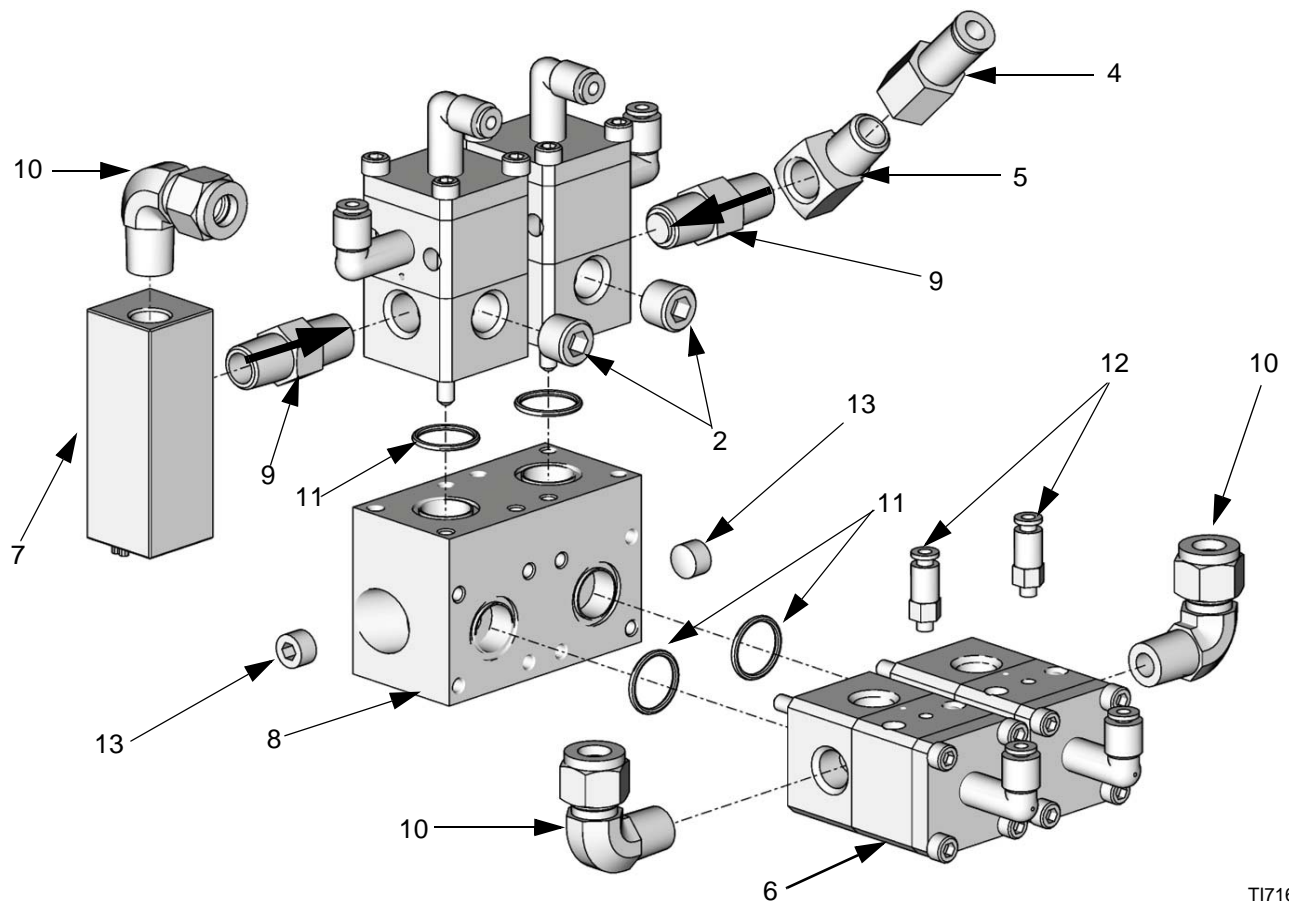

T17162a

EasyKey™ Display

Part No. 249964

Ref. No.	Part No.	Description	Qty.
1*		ENCLOSURE	1
2	116320	SWITCH, rocker, power	1
3	117787	LATCH, quarter turn with key, includes 3a	1
3a	117818	• KEY	1
4	111987	CONNECTOR, cord strain relief	1
5		NUT, hex; M5	4
6	111307	WASHER, lock, M5	8
8	C19293	NUT, machine hex; 10-32 UNF	6
9		WIRE, grounding, door	1
10★	253025	DISPLAY, kit	1
11	15D568	ALARM	1
12▲	118334	LABEL, warning	1
13†	223547	WIRE, grounding, unit; 25 ft. (7.6 m)	1
14*	234446	PLATE, application; includes 14a-14f	1
14a◆	255785	• KIT, Retrofit, Circuit Board; includes items 14b-14f; see 312899	1
14b	15D979	• Fuse, quick acting; 0.4 amp	2
14c	114788	• Fuse, time lag; 2 amp	2
14d*		• Screw, machine; 10-24 UNC x .375 in.	2
14e*		• Cover, vented	1
14f	120369	• Power Supply, 24 Vdc	1
15	15D649	HARNESS, connection	1
17	198165	KIT, accessory, RJ45, jack/con	1
18†	120050	CABLE, modular, RJ45, 7 ft	1
19	15G659	LABEL, instruction	1
20	114606	PLUG, hole	1
21†	15G582	HARNESS, wire	1

★ *Display Kit 253025 does not contain a replacement display board software chip. Save software chip from existing board or order software upgrade kit 249989 separately.*

▲ *Replacement Warning labels, tags, cards are available at no cost.*

† *Not shown.*

* *Not a replacement part*

◆ *If your EasyKey™ has been converted with Retrofit Kit 255785 and you need to replace only the circuit board, order Part No. 255786 Board Replacement Kit.*

Kits Available:

Part No.	Description
197902	EasyKey™ Display Paint Shields, package of 10
249989	Mix Programmed Upgrade Kit; includes software chip, chip extractor tool, and grounding wrist strap.

Replacement Cables:

Part No.	Description
15G869	Ethernet Cable

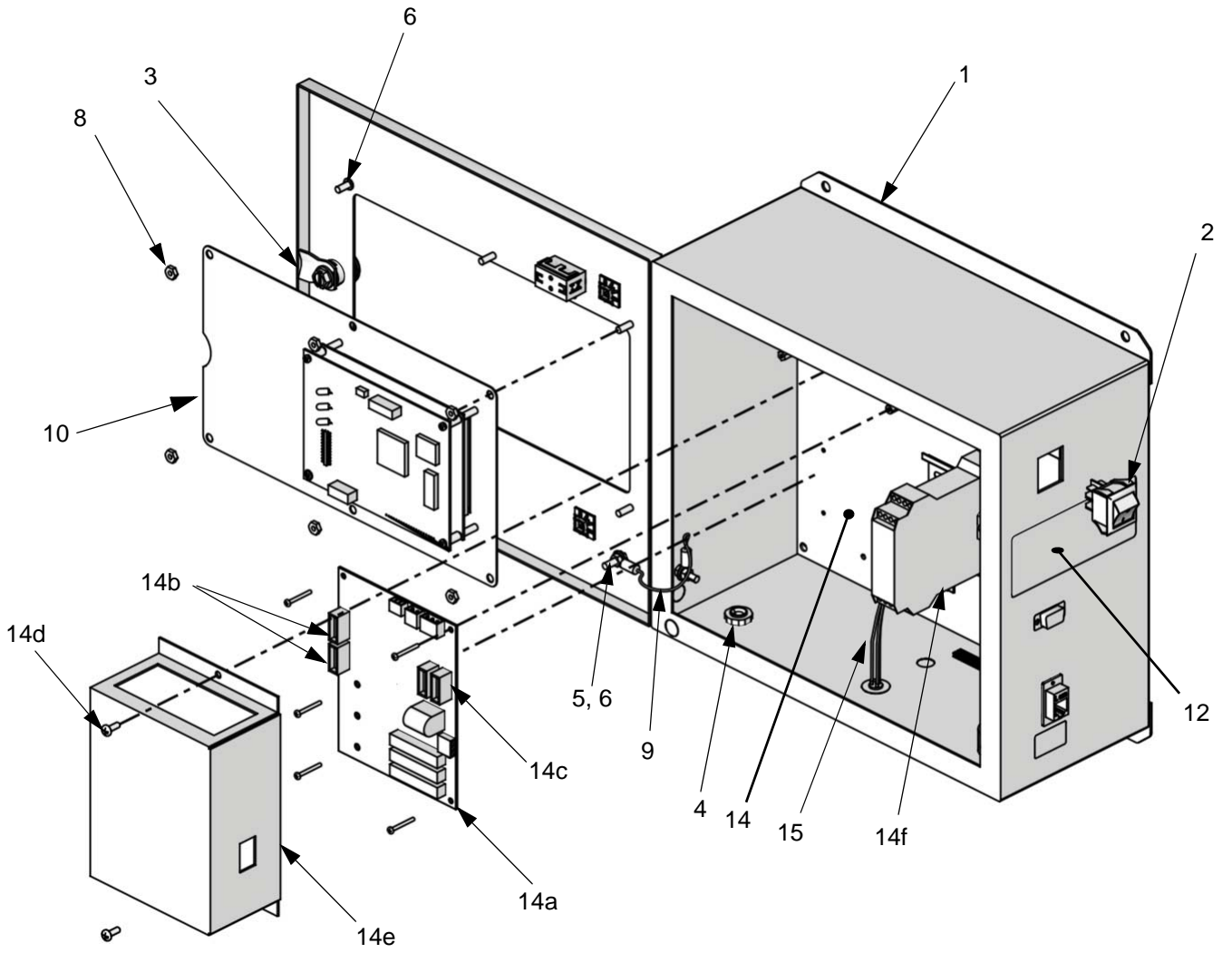

TI4530b

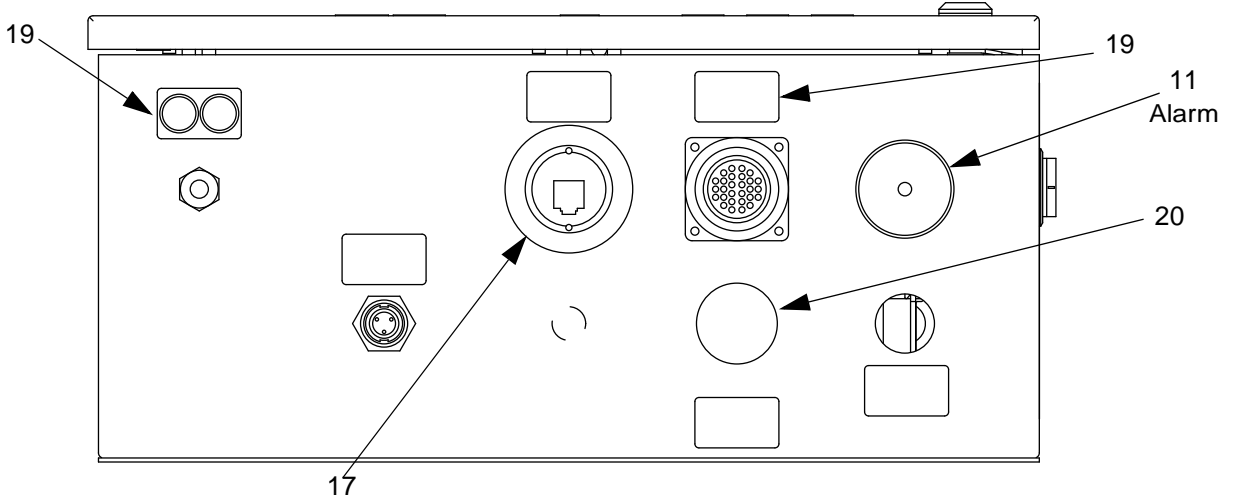

Flow Control Regulator

Part No. 249849

Ref. No.	Part No.	Description	Qty
1*	102980	NUT, full hex	1
2★*	111316	PACKING, o-ring	1
3	112698	ELBOW, male, swivel	1
4*	117610	O-RING	1
5		FASTENER, shcs, 10-32X.5	12
6		PLATE, fluid, regulator	1
7	15F799	PLATE, air, regulator	1
9*		SEAT, regulator	1
10*		RETAINER, seat	1
11		HOUSING, flow control	1
12*		SPACER, regulator	1
13*		NEEDLE, regulator	1
14		BRACKET, flow control	1
15	15F806	PLUG, regulator	1
16*	168881	GASKET, non-metallic	1
17*	178321	DIAPHRAGM, regulator	1
18	249179	BOARD, circuit assembly	1
19	120013	VALVE, proportional, V/P (includes 19a and 19b)	1
19a		SCREW; M3 x 0.5 x 44 mm mounting shcs	2
19b	106560	O-RING, mounting, size 007	2
20★		SENSOR, flush mount	1
21	107295	SCREW, mach, pan hd	4
22	104765	PLUG, pipe headless	1
23*	192387	PIN, dowel	2
24	15G613	HARNESS, flow control	1

* Parts included in Regulator Service Kit 15G843 (purchase separately).

★ Parts included in Sensor Service Kit 15G867 (purchase separately).

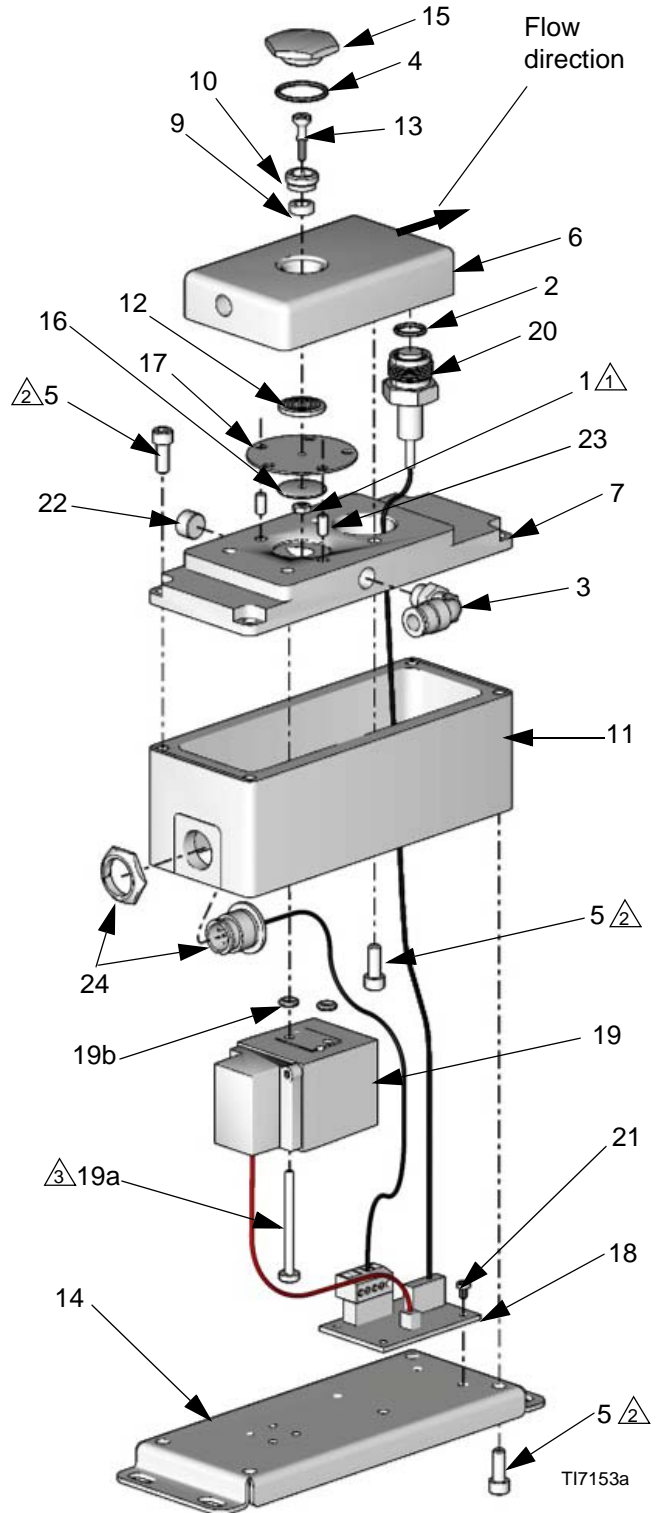

① Torque to 8-10 in-lbs (0.9-1.1 N•m)

② Torque to 30-40 in-lbs (3.4-4.5 N•m)

③ Torque to 5-7 in-lbs (0.6 -0.8 N•m)

Color Change Control System

Part Numbers:

- 249868 2 color changes (3 valves)
- 249869 4 color changes (5 valves)
- 249870 7 color changes (8 valves)

Ref. No.	Part No.	Description	Qty.
1		MANIFOLD	1
2		ENCLOSURE	1
3		COVER	1
4★	15G600	SOLENOID, valve, with flying lead	-
5★	15G561	PLATE, blanking, manifold	-
6	249437	BOARD, circuit assembly	1
7★	109193	FITTING, tube, male, elbow	-
8	597151	FITTING, elbow	1
9	120081	CONNECTOR, plug, 16 position	1
10	100139	PLUG, pipe	1
12	113783	SCREW, mach, PNHD, 1/4-20 UNC-2A	2
13	109032	SCREW, mach, PNHD, 10-32 x 1/4	4
14	112324	SCREW, mach, PNHD, 4-40 x 1/4	4
15★	112116	SCREW, mach, PNHD, M3 x 0.5	-
16★	103557	PACKING, o-ring	-
17	15G691	LABEL	1

★Refer to table for quantity and corresponding Color Change Control assembly number.

Assembly	Reference Number/Quantities				
	4	5	7	15	16
249868	3	5	3	20	5
249869	5	3	5	12	3
249870	8	-	8	-	-

Model 249869 shown

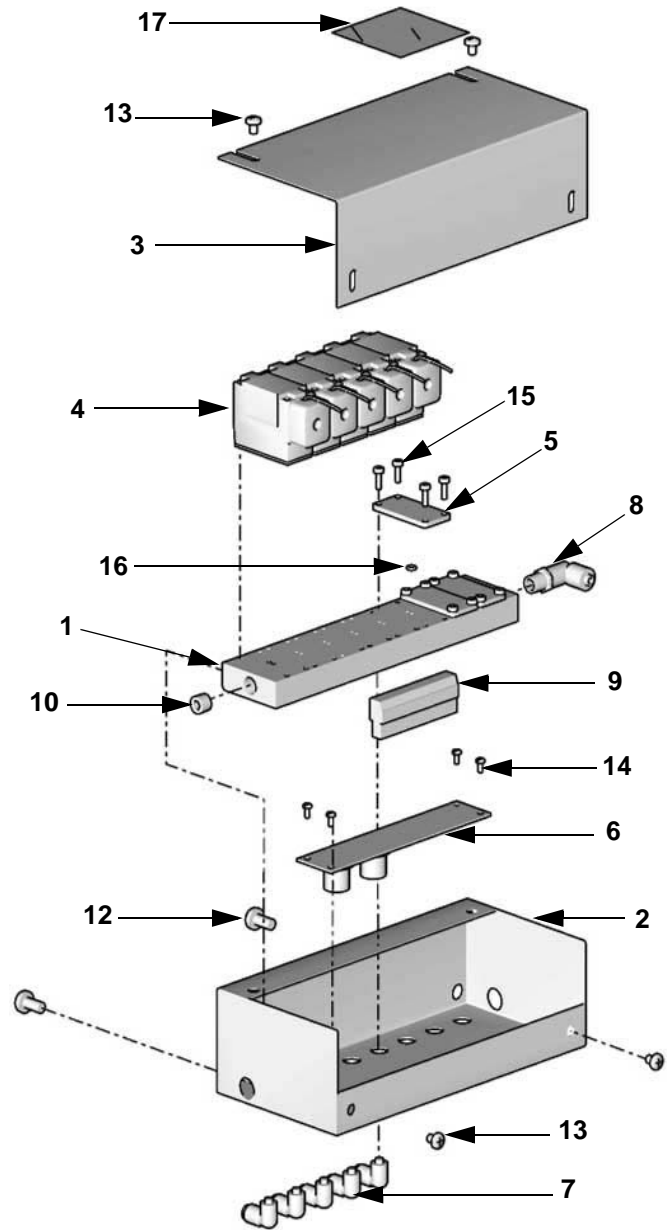

TI7180a

Technical Data

Maximum fluid working pressure	see page 3
Maximum working air pressure	100 psi (0.7 MPa, 7 bar)
Air supply	75–100 psi (0.5–0.7 MPa, 5.2–7 bar)
Air filtration	10 micron (minimum) filtration required; clean and dry air
Mixing ratio range	0.1:1–30:1*
On-ratio accuracy	up to $\pm 1\%$, user selectable
Fluids handled	one or two component: <ul style="list-style-type: none"> • solvent and waterborne paints • polyurethanes • epoxies • acid catalyzed varnishes • moisture sensitive isocyanates
Viscosity range of fluid	20–5000 cps*
Fluid filtration	100 mesh minimum
Fluid flow rate range*	
G3000, G250 Meter	75–3000 cc/min. (0.02–0.79 gal./min.)
G3000HR, G250HR Meter	38–1500 cc/min. (0.01–0.40 gal./min.)
Coriolis Meter	20–3800 cc/min. (0.005–1.00 gal./min.)
External Power Supply Requirements	85–250 Vac, 50/60 Hz, 2 amps maximum draw 15 amp maximum circuit breaker required 8 to 14 AWG power supply wire gauge
Operating temperature range	41–122° F (5–50° C)
Environmental Conditions Rating	Indoor use, Pollution degree (2). Installation category II.
Noise Level	
Sound pressure level	below 70 dBA
Sound power level	below 85 dBA
Wetted parts	303, 304 SST, 17–4 SST, Tungsten carbide (with nickel binder), perfluoroelastomer; PTFE; CV75
Weight	
Base System Total (no meters color change valves)	66.6 lbs (30.2 kg)
EasyKey™ Display	22.2 lbs (10.1 kg)
Wall Mount Fluid Panel (no meters)	41.3 lbs (18.7 kg)
RoboMix II	26.5 lbs (12.0 kg)
Flow Control	4.0 lbs (1.8 kg)
Optional Components	
G3000, G3000HR Flow Meter	6 lbs. (2.7 kg) each
G250, G250HR Flow Meter	4.5 lbs (2.0 kg) each
Coriolis Flow Meter	33 lbs. (15 kg) each
Low Pressure Color Change Stack (6 color)	3.0 lbs (1.4 kg)
High Pressure Color Change Stack (6 color)	11.0 lbs (5.0 kg)

* Dependent on programmed K-factor and application. The ProMix™ Auto maximum allowable flow meter pulse frequency is 425 Hz (pulses/sec.). For more detailed information on viscosities, flow rates, or mixing ratios, consult your Graco distributor.

See individual component manuals for additional technical data.

Graco Standard Warranty

Graco warrants all equipment referenced in this document which is manufactured by Graco and bearing its name to be free from defects in material and workmanship on the date of sale to the original purchaser for use. With the exception of any special, extended, or limited warranty published by Graco, Graco will, for a period of twelve months from the date of sale, repair or replace any part of the equipment determined by Graco to be defective. This warranty applies only when the equipment is installed, operated and maintained in accordance with Graco's written recommendations.

This warranty does not cover, and Graco shall not be liable for general wear and tear, or any malfunction, damage or wear caused by faulty installation, misapplication, abrasion, corrosion, inadequate or improper maintenance, negligence, accident, tampering, or substitution of non-Graco component parts. Nor shall Graco be liable for malfunction, damage or wear caused by the incompatibility of Graco equipment with structures, accessories, equipment or materials not supplied by Graco, or the improper design, manufacture, installation, operation or maintenance of structures, accessories, equipment or materials not supplied by Graco.

This warranty is conditioned upon the prepaid return of the equipment claimed to be defective to an authorized Graco distributor for verification of the claimed defect. If the claimed defect is verified, Graco will repair or replace free of charge any defective parts. The equipment will be returned to the original purchaser transportation prepaid. If inspection of the equipment does not disclose any defect in material or workmanship, repairs will be made at a reasonable charge, which charges may include the costs of parts, labor, and transportation.

THIS WARRANTY IS EXCLUSIVE, AND IS IN LIEU OF ANY OTHER WARRANTIES, EXPRESS OR IMPLIED, INCLUDING BUT NOT LIMITED TO WARRANTY OF MERCHANTABILITY OR WARRANTY OF FITNESS FOR A PARTICULAR PURPOSE.

Graco's sole obligation and buyer's sole remedy for any breach of warranty shall be as set forth above. The buyer agrees that no other remedy (including, but not limited to, incidental or consequential damages for lost profits, lost sales, injury to person or property, or any other incidental or consequential loss) shall be available. Any action for breach of warranty must be brought within two (2) years of the date of sale.

GRACO MAKES NO WARRANTY, AND DISCLAIMS ALL IMPLIED WARRANTIES OF MERCHANTABILITY AND FITNESS FOR A PARTICULAR PURPOSE, IN CONNECTION WITH ACCESSORIES, EQUIPMENT, MATERIALS OR COMPONENTS SOLD BUT NOT MANUFACTURED BY GRACO. These items sold, but not manufactured by Graco (such as electric motors, switches, hose, etc.), are subject to the warranty, if any, of their manufacturer. Graco will provide purchaser with reasonable assistance in making any claim for breach of these warranties.

In no event will Graco be liable for indirect, incidental, special or consequential damages resulting from Graco supplying equipment hereunder, or the furnishing, performance, or use of any products or other goods sold hereto, whether due to a breach of contract, breach of warranty, the negligence of Graco, or otherwise.

FOR GRACO CANADA CUSTOMERS

The Parties acknowledge that they have required that the present document, as well as all documents, notices and legal proceedings entered into, given or instituted pursuant hereto or relating directly or indirectly hereto, be drawn up in English. Les parties reconnaissent avoir convenu que la rédaction du présente document sera en Anglais, ainsi que tous documents, avis et procédures judiciaires exécutés, donnés ou intentés, à la suite de ou en rapport, directement ou indirectement, avec les procédures concernées. Graco Information

Graco Information

For the latest information about Graco products, visit www.graco.com.

For patent informations, go to www.graco.com/patents.

TO PLACE AN ORDER, contact your Graco distributor or call to identify the nearest distributor.

Phone: 612-623-6921 **or Toll Free:** 1-800-328-0211, **Fax:** 612-378-3505

*All written and visual data contained in this document reflects the latest product information available at the time of publication.
Graco reserves the right to make changes at any time without notice.*

Original instructions. This manual contains English. MM 311189

Graco Headquarters: Minneapolis

International Offices: Belgium, China, Japan, Korea

GRACO INC. AND SUBSIDIARIES • P.O. BOX 1441 • MINNEAPOLIS, MN • 55440-1441

Copyright 2006, Graco Inc. All Graco manufacturing locations are registered to ISO 9001.

www.graco.com

Revision L, 07/2017