

Instructions



Integrated Air Control

3A3465A
EN

For use with PD2K for using automatic spray guns. For professional use only.
Not approved for use in explosive atmospheres or hazardous locations.



Important Safety Instructions

Read all warnings and instructions in this manual. **Save these instructions.**

See page 3 for model information.

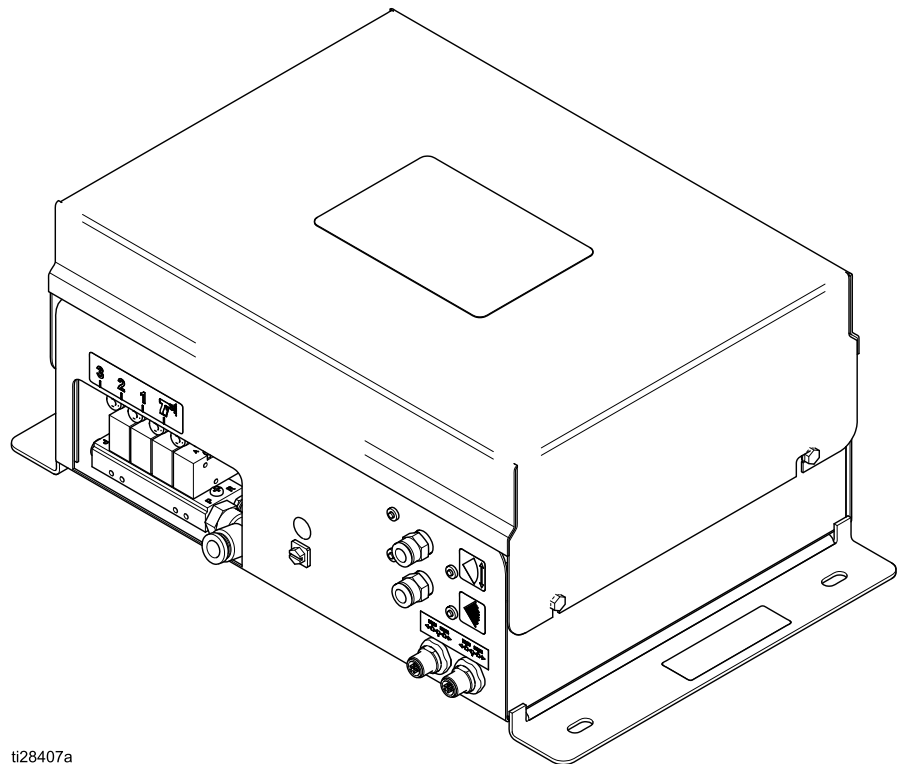

ti28407a



PROVEN QUALITY. LEADING TECHNOLOGY.

Contents

Models	3	Troubleshooting	16
Related Manuals	3	Repair	18
Warnings	4	Cover Removal	18
Introduction	7	Voltage to Pressure Repair	18
Installation	7	Fan Air Solenoid Repair	19
Mounting the Air Control Enclosure	8	Atomizing Air Solenoid Repair	19
CAN Connections	8	Paint Trigger/Auxiliary Air Solenoid	
Air Connections	8	Repair	19
Grounding	8	Fluid Control Module Repair	20
Components	9	Cover Reattachment	20
Operation	14	Notes	21
Pressure Relief Procedure	14	Parts	22
Air Operations	14	Dimensions	24
Maintenance	15	Technical Data	25
Install Upgrade and Key Tokens	15		

Models

Part No.	Series	Maximum Air Working Pressure
26A010	A	100 psi (0.7 MPa, 7.0 bar)







Related Manuals



Manual No.	Description
313516	Air Pro Automatic Spray Guns
313869	Air Pro EFX Automatic Spray Guns





Manual No.	Description
332992	Pro Xpc Auto Electrostatic Spray Guns
311052	G40 Automatic Air-Assisted Spray Guns

Warnings

The following warnings are for the setup, use, grounding, maintenance and repair of this equipment. The exclamation point symbol alerts you to a general warning and the hazard symbol refers to procedure-specific risks. When these symbols appear in the body of this manual or on warning labels, refer back to these Warnings. Product-specific hazard symbols and warnings not covered in this section may appear throughout the body of this manual where applicable.

 <h2 style="margin: 0;">WARNING</h2>	
   	<p>FIRE AND EXPLOSION HAZARD</p> <p>Flammable fumes, such as solvent and paint fumes, in work area can ignite or explode. Paint or solvent flowing through the equipment can cause static sparking. To help prevent fire and explosion:</p> <ul style="list-style-type: none"> • Use equipment only in well ventilated area. • Eliminate all ignition sources; such as pilot lights, cigarettes, portable electric lamps, and plastic drop cloths (potential static sparking). • Ground all equipment in the work area. See Grounding instructions. • Never spray or flush solvent at high pressure. • Keep work area free of debris, including solvent, rags and gasoline. • Do not plug or unplug power cords, or turn power or light switches on or off when flammable fumes are present. • Use only grounded hoses. • Hold gun firmly to side of grounded pail when triggering into pail. Do not use pail liners unless they are anti-static or conductive. • Stop operation immediately if static sparking occurs or you feel a shock. Do not use equipment until you identify and correct the problem. • Keep a working fire extinguisher in the work area.
 	<p>ELECTRIC SHOCK HAZARD</p> <p>This equipment must be grounded. Improper grounding, setup, or usage of the system can cause electric shock.</p> <ul style="list-style-type: none"> • Turn off and disconnect power at main switch before disconnecting any cables and before servicing or installing equipment. • Connect only to grounded power source. • All electrical wiring must be done by a qualified electrician and comply with all local codes and regulations.

 <h1 style="margin: 0;">WARNING</h1>	
	<p>SKIN INJECTION HAZARD</p> <p>High-pressure fluid from gun, hose leaks, or ruptured components will pierce skin. This may look like just a cut, but it is a serious injury that can result in amputation. Get immediate surgical treatment.</p> <ul style="list-style-type: none"> • Do not spray without tip guard and trigger guard installed. • Engage trigger lock when not spraying. • Do not point gun at anyone or at any part of the body. • Do not put your hand over the spray tip. • Do not stop or deflect leaks with your hand, body, glove, or rag. • Follow the Pressure Relief Procedure when you stop spraying and before cleaning, checking, or servicing equipment. • Tighten all fluid connections before operating the equipment. • Check hoses and couplings daily. Replace worn or damaged parts immediately.
	<p>EQUIPMENT MISUSE HAZARD</p> <p>Misuse can cause death or serious injury.</p> <ul style="list-style-type: none"> • Do not operate the unit when fatigued or under the influence of drugs or alcohol. • Do not exceed the maximum working pressure or temperature rating of the lowest rated system component. See Technical Data in all equipment manuals. • Use fluids and solvents that are compatible with equipment wetted parts. See Technical Data in all equipment manuals. Read fluid and solvent manufacturer's warnings. For complete information about your material, request MSDS from distributor or retailer. • Do not leave the work area while equipment is energized or under pressure. • Turn off all equipment and follow the Pressure Relief Procedure when equipment is not in use. • Check equipment daily. Repair or replace worn or damaged parts immediately with genuine manufacturer's replacement parts only. • Do not alter or modify equipment. Alterations or modifications may void agency approvals and create safety hazards. • Make sure all equipment is rated and approved for the environment in which you are using it. • Use equipment only for its intended purpose. Call your distributor for information. • Route hoses and cables away from traffic areas, sharp edges, moving parts, and hot surfaces. • Do not kink or over bend hoses or use hoses to pull equipment. • Keep children and animals away from work area. • Comply with all applicable safety regulations.

 WARNING	
 	<p>TOXIC FLUID OR FUMES Toxic fluids or fumes can cause serious injury or death if splashed in the eyes or on skin, inhaled, or swallowed.</p> <ul style="list-style-type: none">• Read Safety Data Sheet (SDS) to know the specific hazards of the fluids you are using.• Store hazardous fluid in approved containers, and dispose of it according to applicable guidelines.
	<p>PERSONAL PROTECTIVE EQUIPMENT Wear appropriate protective equipment when in the work area to help prevent serious injury, including eye injury, hearing loss, inhalation of toxic fumes, and burns. This protective equipment includes but is not limited to:</p> <ul style="list-style-type: none">• Protective eyewear, and hearing protection.• Respirators, protective clothing, and gloves as recommended by the fluid and solvent manufacturer.



Introduction

The Integrated Air Control is designed to control spray parameters for automatic spray guns as part of a paint coating system.

The Integrated Air Control provides the flexibility to control atomizing and fan air with a variable setpoint. Atomizing and fan air can be enabled or disabled independently. Also included is the ability to control the paint trigger.

Three auxiliary solenoids are provided that customers can use to activate features or components such as air cap cleaners and dump valves.

Installation

				
<p>Installing and servicing this equipment requires access to parts which may cause electrical shock or serious injury if work is not performed properly. Do not install or service this equipment unless you are trained and qualified.</p>				

The following figure, which includes the Integrated Air Control, is not an actual system design. Contact your Graco distributor for assistance in designing your system.

Typical Installation

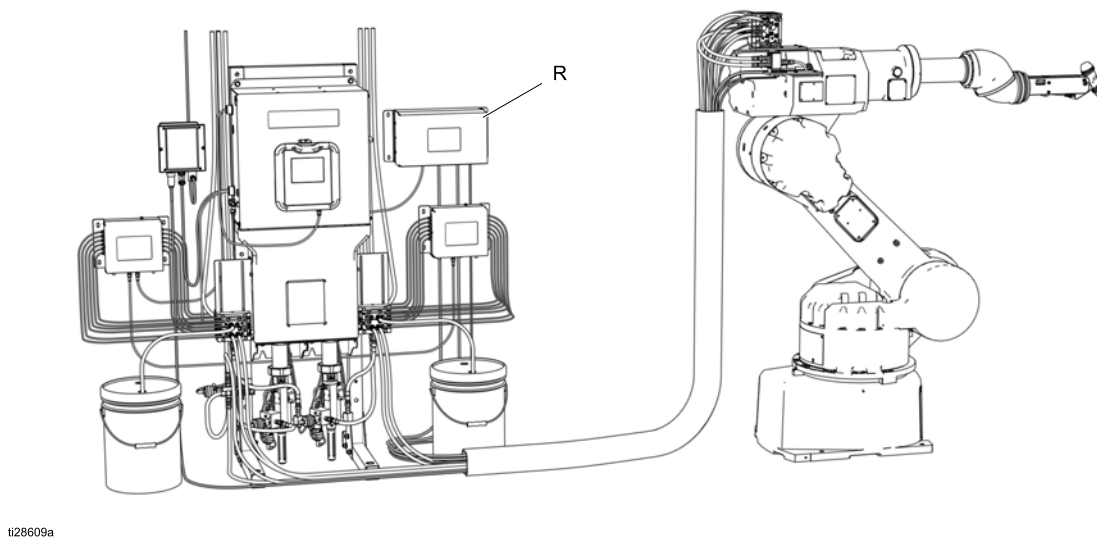

Key:

ID	Component
R	Integrated Air Control

The steps in all of the following procedures apply only to the integrated air control (R).

Mounting the Air Control Enclosure

1. Select a location close to the other components in your system (see the figure in [Typical Installation](#)), and outside of the hazardous location area. Provide sufficient clearance to remove the cover and to attach cables and air lines.
2. Use the Mounting Layout in [Dimensions, page 24](#), to locate and drill mounting holes.
3. Secure the air control enclosure before attaching the CAN cables and air lines.

CAN Connections

The air control module receives commands and power through the CAN connections. The module is wired in series with other system components.

1. Connect an unattached CAN cable from one of the neighboring system components to either of the CAN connections (K).
2. Connect a second CAN cable to the other CAN connection. The other end of this cable will be attached to the next component in series.

Air Connections

NOTE: If your air source does not have a filter, install an air filter to ensure a dry, clean air supply to the gun. Dirt and moisture can ruin the appearance of your finished workpiece.

Inlet Air

Connect the compressed air supply inlet using a 3/8 in. (9.5 mm) OD hose. See the air inlet (L) on the Air Control Enclosure in [Components, page 9](#).

Outlet Air

1. Attach one end of a 5/16 in. (8 mm) OD hose to the fan air outlet (H) on the Air Control Enclosure in [Components, page 9](#). Route the other end to the fan air inlet on the gun. Refer to the Installation manual for your gun.

2. Attach one end of a 5/16 in. (8 mm) OD hose to the atomizing air outlet (J). Route other end to the atomizing air inlet on the gun. Refer to the Installation manual for your gun.
3. Attach one end of a 5/32 in. (4 mm) OD hose to the paint trigger solenoid (D). Route the other end to the paint trigger inlet on the gun. Refer to the Installation manual for your gun.
4. Attach one end of a 5/32 in. (4 mm) OD hose to the auxiliary 1 solenoid (E).
5. Attach one end of a 5/32 in. (4 mm) OD hose to the auxiliary 2 solenoid (F).
6. Attach one end of a 5/32 in. (4 mm) OD hose to the auxiliary 3 solenoid (G).

NOTE: Examples for how to use auxiliary solenoids include air cap cleaners and dump valves.

Grounding



Verify the ground wire is attached to the ground screw (P), and the screw is attached securely to the air control enclosure. Connect the other end of ground wire to an earth ground.

Components

Air Control Enclosure

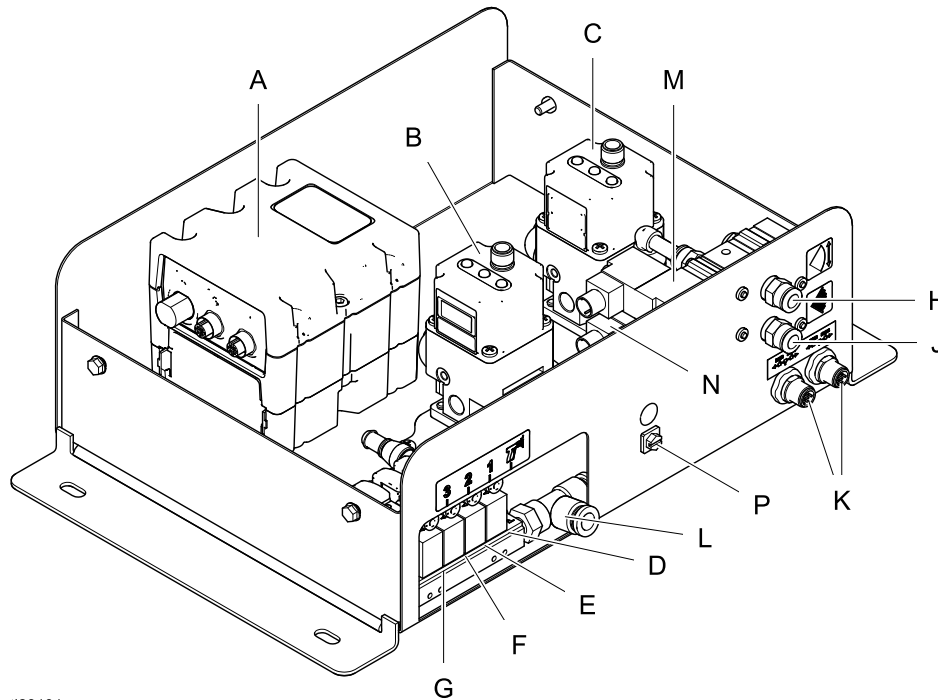

ti28131a

Figure 1 Air Control Components

Key:

ID	Component
A	Fluid Control Module (FCM)
B	Voltage to Pressure (V2P) Regulator (Atomizing Air)
C	Voltage to Pressure (V2P) Regulator (Fan Air)
D	Paint Trigger Solenoid
E	Auxiliary 1 Solenoid
F	Auxiliary 2 Solenoid
G	Auxiliary 3 Solenoid
H	Fan Air Outlet
J	Atomizing Air Outlet
K	CAN Connections
L	Air Inlet
M	Fan Air Solenoid
N	Atomizing Air Solenoid
P	Ground Screw

Fluid Control Module

The Air Control uses a Fluid Control Module (FCM) to manage the inlet and outlet of air.

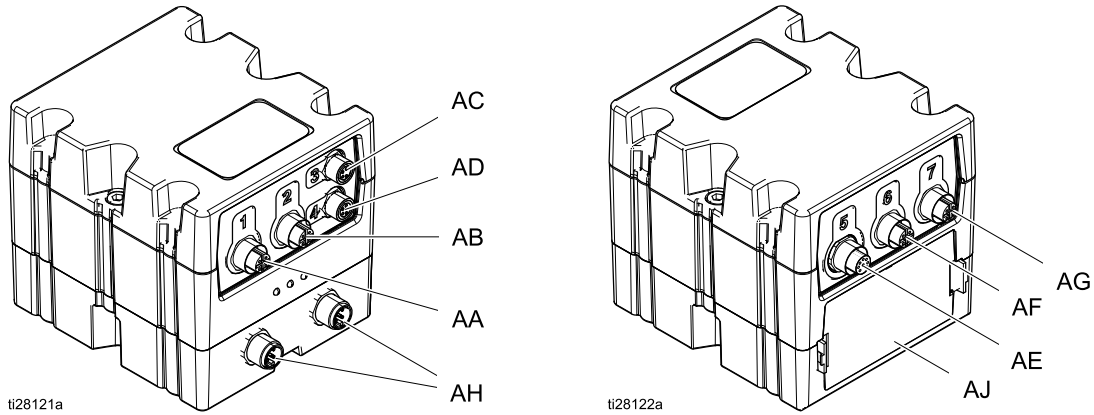

Key:

ID	Description
AA	Port 1: Splitter cable to the shaping solenoids: 1. Fan 2. Atomizing
AB	Port 2: Splitter cable to the SMC solenoids: 1. Paint Trigger 2. Auxiliary 1 3. Auxiliary 2 4. Auxiliary 3
AC	Port 3: Control to the Atomizing Air Voltage to Pressure regulator
AD	Port 4: Control to the Fan Air Voltage to Pressure regulator
AE	Port 5: Not Used
AF	Port 6: Pressure Feedback from the Atomizing Air Voltage to Pressure regulator
AG	Port 7: Pressure Feedback from the Fan Air Voltage to Pressure regulator
AH	CAN Connection: Supplies power and communication to the GCA components.
AJ	Access Cover

Voltage to Pressure Regulator

The atomizing air and fan air Voltage to Pressure (V2P) regulators (B & C, respectively) translate voltage from the Fluid Control Module (A) into air pressure to the atomizing and fan air solenoids (N & M, respectively). The atomizing air regulator (B) is shown below.

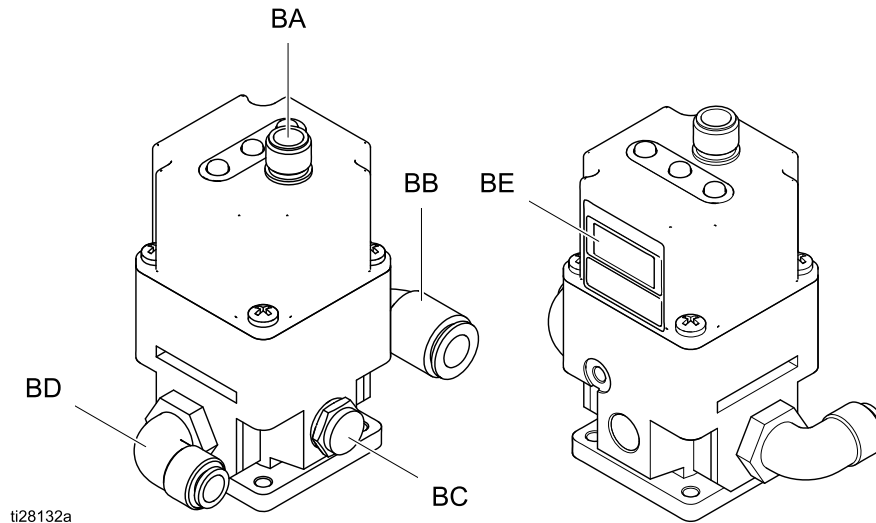

Figure 2 V2P Connections

Key:

ID	Description
BA*	Control from the Fluid Control Module
BB*	Inlet air from the inlet air connection (L)
BC*	Muffler
BD*	Outlet air to the air solenoid
BE*	Digital display

* Though the IDs and descriptions in this table are specific to the atomizing air regulator (B), they are also applicable to the fan air regulator (C). Refer to [Components, page 9](#) .

Paint Trigger / Auxiliary Solenoids

The paint trigger (D) and auxiliary 1–3 (E, F, and G) each use the same type of solenoid valve (12). All are controlled by commands from the Fluid Control Module (A). The paint trigger solenoid (D) is shown below.

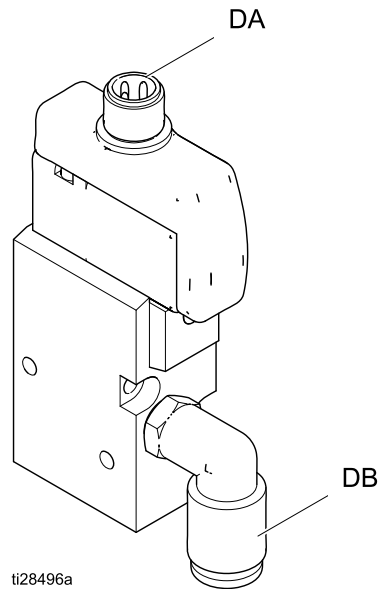

Figure 3 Paint Trigger / Auxiliary Connections

Key:

ID	Description
DA*	Control from the Fluid Control Module (A)
DB*	Outlet air

* Though the IDs and descriptions in this table are specific to the paint trigger solenoid (D), they are also applicable to the auxiliary 1 solenoid (E), the auxiliary 2 solenoid (F), and the auxiliary 3 solenoid (G). Refer to [Components, page 9](#).

Atomizing / Fan Air Solenoids

Identical solenoids are used for both the Fan Air (M) and the Atomizing Air (N). Both are controlled by commands from the Fluid Control Module (A). The fan air solenoid (M) is shown below.

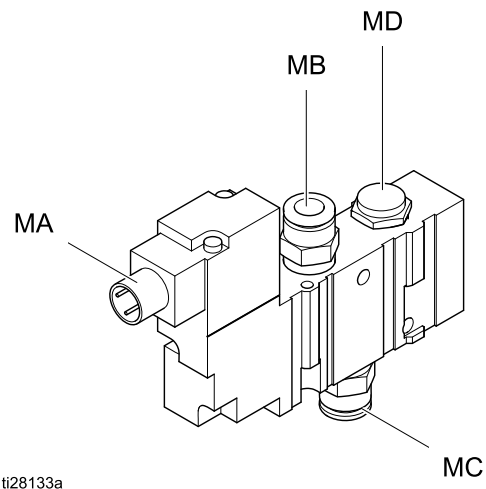

ti28133a

Figure 4 Atomizing / Fan Air Solenoid Connections

Key:

ID	Description
MA*	Control from Fluid Control Module
MB*	Air Inlet
MC*	Air Outlet
MD*	Muffler

* Though the IDs and descriptions in this table are specific to the fan air solenoid (M), they are also applicable to the atomizing air solenoid (N). Refer to [Components, page 9](#) .

Operation

Pressure Relief Procedure



Follow the **Pressure Relief Procedure** whenever you see this symbol.



This equipment stays pressurized until pressure is manually relieved. To help prevent serious injury from pressurized fluid, such as skin injection or splashing fluid, follow the **Pressure Relief Procedure** when you stop spraying and before cleaning, checking, or servicing the equipment. When turned off, all air valves bleed to atmosphere.

1. Relieve pressure from air inlet supply before connecting air to inlet (L) of the enclosure.
2. Follow the **Pressure Relief Procedure** in the applicable gun manuals. See [Related Manuals, page 3](#).

Air Operations

Paint Trigger

The signal solenoid for the paint trigger can only be enabled or disabled. The solenoid will supply the pressure equal to the inlet pressure.

NOTE: If the paint trigger does not turn off quick enough, add a quick exhaust (Part No. 104661) closer to the gun.

Atomizing / Fan Air

Atomizing Air

Atomizing air can be adjusted from 0–99 psi (0–0.68 MPa, 0–6.8 bar). Atomizing air can be enabled/disabled independently.

The atomizing air solenoid is rated for an air flow of 1.5 Cv. The voltage-to-pressure regulator has a maximum flow rate of 50 scfm (1500 l/min).

Fan Air

Fan air can be adjusted from 0–99 psi (0–0.68 MPa, 0–6.8 bar). Fan air can be enabled/disabled independently.

The fan air solenoid is rated for an air flow of 1.5 Cv. The voltage-to-pressure regulator has a maximum flow rate of 50 scfm (1500 l/min).

Auxiliary Solenoids

The signal solenoids for the auxiliary air outlets can only be enabled or disabled. Example applications for auxiliary air solenoids include:

- air cap cleaner vacuum enable,
- air cap cleaner dry air enable,
- air cap cleaner solvent enable,
- dump valve enable.

Solenoids are rated for an air flow of 0.13 Cv. If an application requires more air flow, install an air volume booster (Part No. 120435) and use the auxiliary solenoid as a pilot line.

Auxiliary solenoids can only be controlled over the network. (Example: EtherNet/IP, Profinet, DeviceNet, Modbus TCP, etc.)

Maintenance

Install Upgrade and Key Tokens

NOTE: Fluid Control Module (FCM) connection to the system is temporarily disabled during the installation of upgrade or key tokens.

1. Ensure the system is inactive.
2. Remove access cover (AJ).

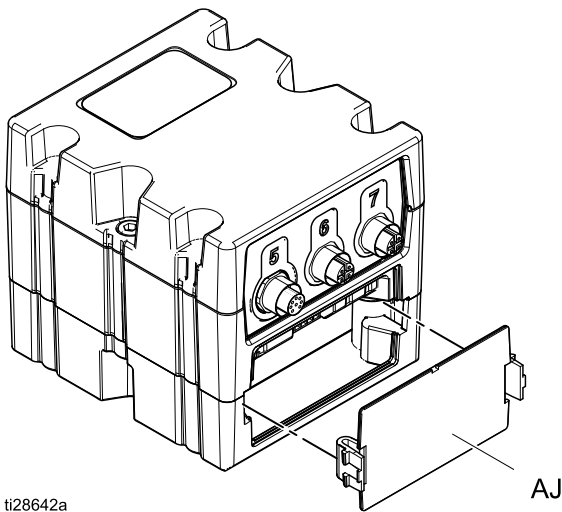

3. Insert and press token (T) firmly into slot.

NOTE: There is no preferred orientation of token.

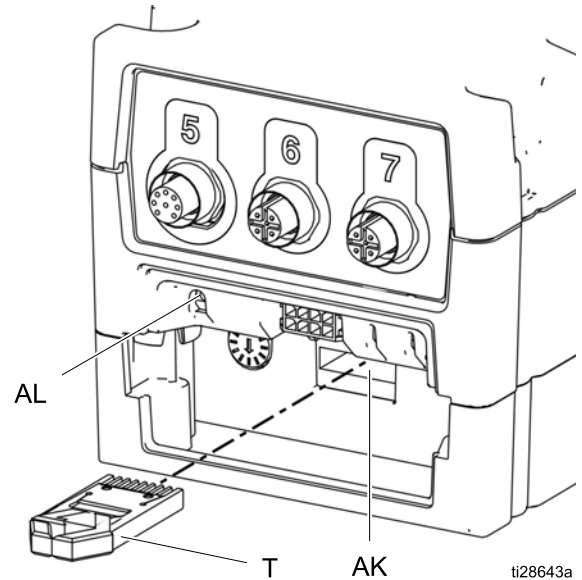

4. Press and hold button the push button (AK) for three seconds and then release. The red LED (AL) will flash until the software is uploaded.
5. Remove token (T) when software has successfully uploaded or key token is no longer required.

NOTE: Upgrade tokens can be removed once the software has been successfully uploaded. If key tokens are used by your Graco Control Architecture based system, they must remain in the FCM for features or settings to be enabled. Key tokens are not present on all Graco Control Architecture based settings.

6. Replace the access cover (AJ).

Troubleshooting

NOTE: In the table below, letters in parentheses refer to components with specific purposes (see [Components, page 9](#)) and numbers in parentheses refer to find numbers for individual parts (see [Parts, page 22](#)).

Problem	Cause	Solution
No atomizing air.	Plugged nozzle/air cap.	See your gun repair manual for appropriate solution.
	Atomizing air solenoid (N) not opening.	Replace atomizing air solenoid (5). See Atomizing Air Solenoid Repair, page 19 .
	Atomizing air V2P (B) failure.	Replace V2P (1). See Voltage to Pressure Repair, page 18 .
	Cable failure.	Verify electrical connections between the Fluid Control Module (at AA) and the atomizing air solenoid (at NA).
No fan air.	Plugged nozzle/air cap.	See your applicator repair manual for appropriate solution.
	Fan air solenoid (M) not opening.	Replace fan air solenoid (5). See Fan Air Solenoid Repair, page 19 .
	Fan air V2P (C) failure.	Replace V2P (1). See Voltage to Pressure Repair, page 18 .
	Cable failure.	Verify electrical connections between the Fluid Control Module (at AA) and the fan air solenoid (at MA).
No paint trigger or auxiliary air.	Solenoid (D, E, F, or G) failure.	Verify mechanical operation by pressing the blue override button on the solenoid (12). If air is released, check CAN Connections, page 8 , for missing components and connections.
	Cable failure.	Verify electrical connections between the Fluid Control Module (at AB) and the solenoids (at DA, EA, FA, or GA); the cables from the Fluid Control Module are marked 1, 2, 3, and 4, respectively. See CAN Connections, page 8 .
	No supply air.	Verify air at enclose inlet (L).
Actual air pressure doesn't match target air pressure.	Excessive air drop.	Change size of air hose at air outlet (H or J) to next available larger size. Change the corresponding connector (17) to next available larger size.

Fluid Control Module LED Diagnostic Information

The following LED signals, diagnosis, and solutions apply to the Fluid Control Module.

Module Status LED Signal	Diagnosis	Solution
Green on	System is powered up	—
Yellow	Internal communication in progress	—
Red solid	Hardware failure	Replace module.
Red flashing fast	Uploading software	—
Red flashing slow	Token error	Remove token and upload software token again. See Install Upgrade and Key Tokens , page 15.

Repair

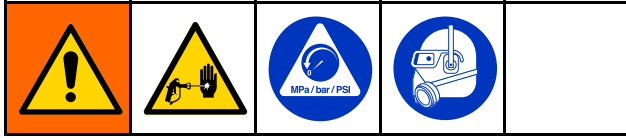

NOTE: In the following procedures, letters in parentheses refer to components with specific purposes (see [Components, page 9](#)) and numbers in parentheses refer to find numbers for individual parts (see [Parts, page 22](#)).

The following diagram represents the electrical connections between the primary components of the integrated air control module.

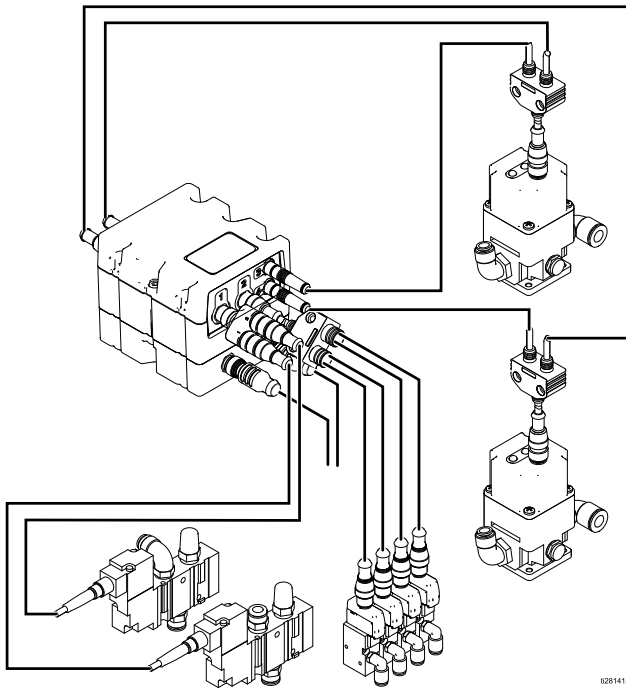

Figure 5 Electrical Connections

Voltage to Pressure Repair

The following instructions apply to both the Atomizing Air (B) and Fan Air (C) V2P regulators. Verify which regulator you are repairing or replacing before removing.

1. Remove the cover (see [Cover Removal, page 18](#)).
2. Remove the split cable (39) on the regulator (1).
3. Remove the inlet (20) and outlet (35) fittings near the base of the regulator.
4. Remove the screws (34) securing the regulator bracket (2) to the enclosure panel (15).
5. Remove the V2P regulator (1) assembly.
6. Separate the regulator (1) from the regulator bracket (2) by loosening the regulator bracket screws at the bottom of the bracket.
7. Orient the new regulator (1) on the regulator bracket (2) so that the inlet port (1 SUP) will face the top of the enclosure and the outlet port (2 OUT) will face the bottom. Secure the regulator to the regulator bracket with the four regulator bracket screws.
8. Verify the orientation of the regulator (1) assembly and attach it to the enclosure panel (15) using the screws (34).
9. Attach the inlet (20) and outlet (35) fittings to the regulator (1).
10. Attach the split cable (39) to the regulator (1).
11. Replace the cover.

Cover Removal

1. Loosen the four screws (31) securing the cover (14) to the enclosure panel (15).
2. Tilt up the bottom of the cover and slide cover off of the two upper screws to remove the cover.

Fan Air Solenoid Repair

1. Remove the cover (see [Cover Removal, page 18](#)).
2. Remove the inlet hose at the fan air inlet (MB).
3. Remove the outlet hose at the fan air outlet (MC).
4. Remove the control cable from the Fluid Control Module (A) at MA.
5. Loosen the two screws (37) securing the solenoid assembly (M) to the enclosure panel (15), and remove the solenoid assembly.
6. If you are removing the atomizing air solenoid (N), see [Atomizing Air Solenoid Repair, page 19](#) before continuing to the next step.
7. Orient the new fan air solenoid (M) with the control port (MA) pointing to the left, and secure the solenoid to the enclosure panel (15) with the two screws (37) at diagonal holes.
8. Attach the control cable from the Fluid Control Module (A) at MA.
9. Attach the outlet hose to the shaping air outlet (MC).
10. Attach the inlet hose to the shaping air inlet (MB).
5. Remove the control cable from the Fluid Control Module (A) at NA.
6. Loosen the two screws (37) securing the solenoid assembly (N) to the enclosure panel (15), and remove the solenoid assembly.
7. Orient the new atomizing air solenoid (N) with the control port (NA) pointing to the left, and secure the solenoid to the enclosure panel (15) with the two screws (37) at diagonal holes.
8. Attach the control cable from the Fluid Control Module (A) at NA.
9. Attach the outlet hose to the shaping air outlet (NC).
10. Attach the inlet hose to the shaping air inlet (NB).
11. Reinstall the fan air solenoid (M), see [Fan Air Solenoid Repair, page 19](#).

Atomizing Air Solenoid Repair

1. Remove the cover (see [Cover Removal, page 18](#)).
2. Before removing the atomizing air solenoid (N), remove the fan air solenoid (M), see [Fan Air Solenoid Repair, page 19](#).
3. Remove the inlet hose at the shaping air inlet (NB).
4. Remove the outlet hose at the shaping air outlet (NC).
1. Disconnect the air hose from the solenoid outlet (24).
2. Disconnect the splitter cable (13).
3. Remove the solenoid (12) by loosening the two screws on the solenoid.
4. Orient the new solenoid (12) with the cable connection facing inwards and the solenoid outlet facing outwards, and secure the solenoid to the enclosure panel with the two screws.
5. Attach the splitter cable (13).
6. Attach the air hose to the solenoid outlet (24).

Paint Trigger/Auxiliary Air Solenoid Repair

The following procedure applies to any of the paint trigger (D) or auxiliary air solenoids (E, F, and G).

Fluid Control Module Repair

1. Disconnect all of the cables leading to and from the Fluid Control Module cube.
2. Remove the Fluid Control Module cube top (6) by using a 5/16" Allen wrench loosen two screws. Removing the top exposes the Fluid Control Module base (7), the grounding screw (33), and the four mounting screws (32).
3. Remove the grounding screw (33).
4. Remove the four mounting screws (32).
5. Remove the Fluid Control Module base (7).
6. Separate the Fluid Control Module top (6) and base (7) of the new FCM, as described in Step 2.
7. Orient the Fluid Control Module base (7) so that the two ports are facing right, and secure the base to the enclosure with the four mounting screws (32).
8. Reconnect the grounding screw (33).
9. Orient the Fluid Control Module top (6) so that ports 5–7 are facing to the left, and secure the top to the base using a 5/16" Allen wrench to tighten the two screws.
10. Reconnect the cables .

Cover Reattachment

1. Align the slotted holes on the cover (14) with the two upper screws (31) on the enclosure panel (15).
2. Secure the bottom of the cover (14) to the enclosure panel (15) with the two bottom screws (31), and tighten the two upper screws (31).

Parts

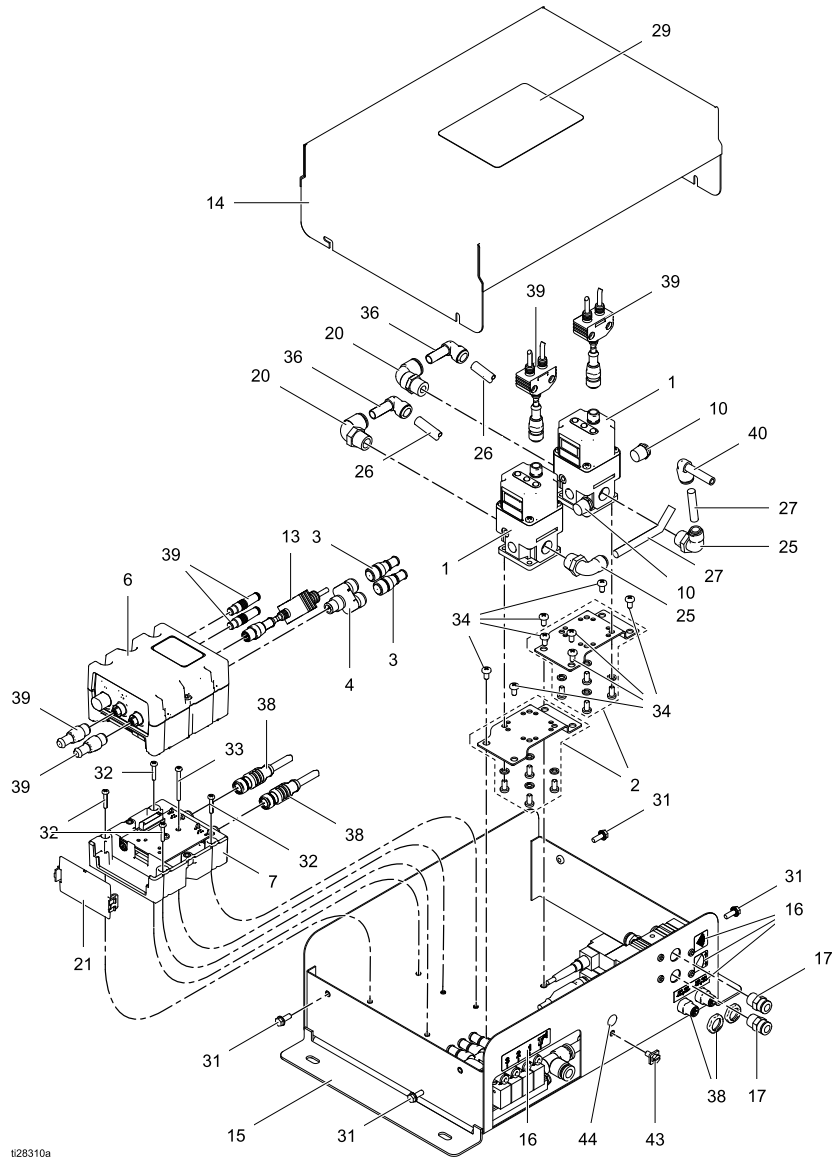

028310a

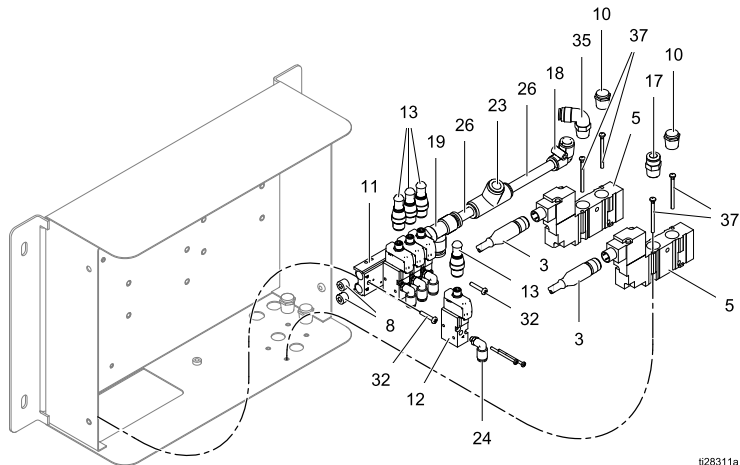

028311a

Ref	Part	Description	Qty
1	17G386	Regulator, electro/pneumatic, 3/8 in. NPT	2
2	17D921	Bracket, regulator	2
3	122030	Cable, GCA, M12–5P	2
4	124273	Connector, splitter	1
5	17K028	Valve, solenoid, 3–way, 1/4 in. NPT	2
6	289696	Module, GCA, cube, Fluid Control Module	1
7	289697	Module, GCA, cube, base	1
8	—	Plug, pipe, 1/8 in. NPT	2
9	—	Muffler, sintered, 1/8 in. NPT(not shown)	1
10	—	Muffler, 1/4 in. NPT	4
11	—	Manifold, 4–position	1
12	17K124	Valve, solenoid, 3–way, M5	4
13	17K240	Cable, splitter, M12 (M) 4x M8 (F)	1
14	—	Cover, enclosure, air control	1
15	—	Panel, air control, painted	1
16	17K720	Label, air control, port ID	1
17	—	Fitting, straight, 1/4 in. NPT (m), 5/16 in.	3
18	—	Fitting, elbow, push-on, 3/8 in. x 3/8 in.	1
19	—	Fitting, run tee, push-on, 1/8 in. NPT x 3/8 in. x 3/8 in.	1
20	—	Fitting, elbow, swivel, 3/8 in. x 3/8 in. NPT	2
21	277674	Enclosure, cube door	1

Ref	Part	Description	Qty
23	—	Tee, 3/8 in. tube push-lock	1
24	—	Fitting, elbow, swivel, M5 x 0.8 x 4 mm	4
25	—	Fitting, elbow, swivel, 5/16 in. x 3.8 in. NPT	2
26	—	Tube, polyethylene, 3/8 in. OD	
27	—	Tube, nylon, round, 5/16 in. (8 mm)	
29	15U918	Label, product, color change module, 2KS	1
31	—	Screw, machine, serrated hex head, 10–32 x 1/2 in.	4
32	—	Screw, machine, pan, 6–32 x 3/4 in.	6
33	—	Screw, machine, pan, 6–32 x 1–1/2 in.	1
34	—	Screw, machine, pan, 10–32 x 3/8 in.	8
35	—	Fitting, elbow, 1/4 in. NPT(M), 5/16 in.	1
36	—	Fitting, elbow, extended, push-on, 3/8 in.	2
37	—	Screw, machine, Phillips, M3 x 0.5, 40 mm	4
38	17K800	Cable, GCA, M12 — 5P, M bulkhead/F	2
39	17K902	Cable, split, M12(M) 1M8(M) M12(M)	2
40	—	Fitting, elbow, extended, push-on, 5/16 in.	1
43	116343	Screw, ground	1
44 [▲]	186620	Label, symbol, ground	1

▲ Replacement Warning labels, signs, tags, and cards are available at no cost.

Dimensions

Mounting Layout

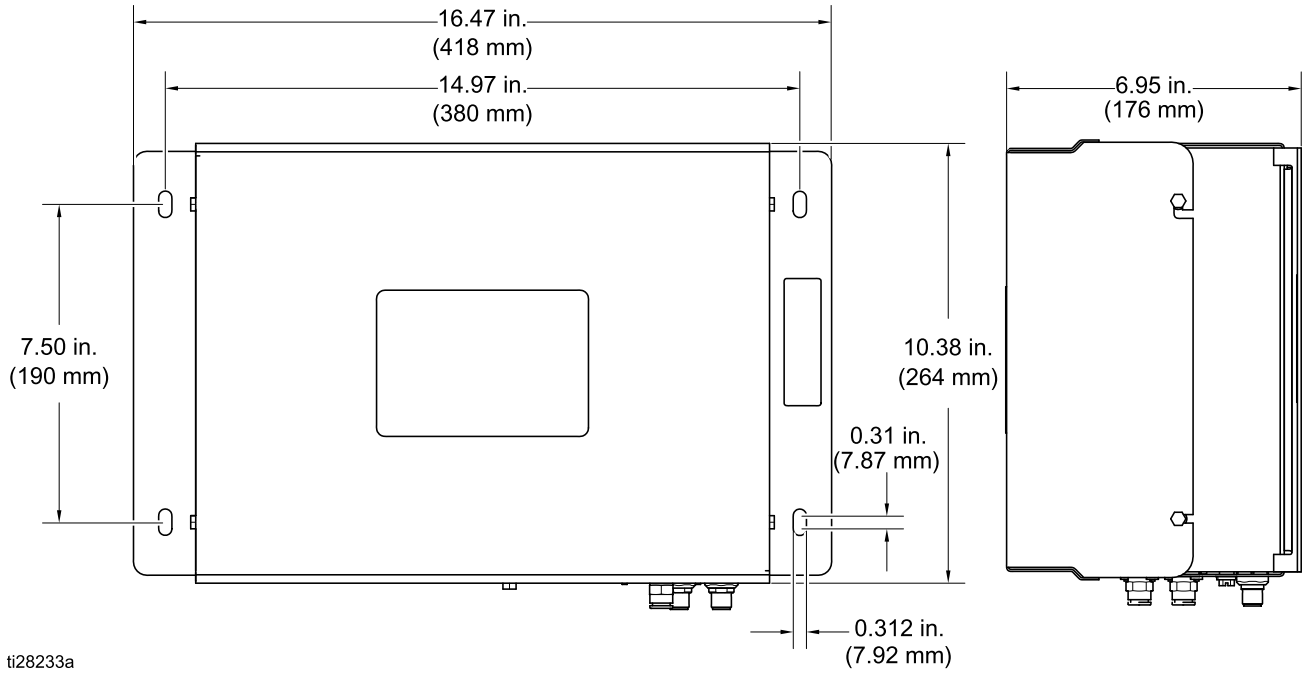

Technical Data

Integrated Air Control	U.S.	Metric
Maximum Air Inlet Pressure	100 psi	7 bar
Inlet Hose	3/8 in.	9.5 mm
Outlet Hoses		
Atomizing Air	5/16 in.	8 mm
Fan Air	5/16 in.	8 mm
Paint Trigger	5/32 in.	4 mm
Auxiliary Air 1	5/32 in.	4 mm
Auxiliary Air 2	5/32 in.	4 mm
Auxiliary Air 3	5/32 in.	4 mm
Voltage	24 VDC	
Current	1 Amp	
Environmental Temperature Range	32 — 122° F	0 — 50° C
Weight	15 lbs.	6.8 kg

Graco Standard Warranty

Graco warrants all equipment referenced in this document which is manufactured by Graco and bearing its name to be free from defects in material and workmanship on the date of sale to the original purchaser for use. With the exception of any special, extended, or limited warranty published by Graco, Graco will, for a period of twelve months from the date of sale, repair or replace any part of the equipment determined by Graco to be defective. This warranty applies only when the equipment is installed, operated and maintained in accordance with Graco's written recommendations.

This warranty does not cover, and Graco shall not be liable for general wear and tear, or any malfunction, damage or wear caused by faulty installation, misapplication, abrasion, corrosion, inadequate or improper maintenance, negligence, accident, tampering, or substitution of non-Graco component parts. Nor shall Graco be liable for malfunction, damage or wear caused by the incompatibility of Graco equipment with structures, accessories, equipment or materials not supplied by Graco, or the improper design, manufacture, installation, operation or maintenance of structures, accessories, equipment or materials not supplied by Graco.

This warranty is conditioned upon the prepaid return of the equipment claimed to be defective to an authorized Graco distributor for verification of the claimed defect. If the claimed defect is verified, Graco will repair or replace free of charge any defective parts. The equipment will be returned to the original purchaser transportation prepaid. If inspection of the equipment does not disclose any defect in material or workmanship, repairs will be made at a reasonable charge, which charges may include the costs of parts, labor, and transportation.

THIS WARRANTY IS EXCLUSIVE, AND IS IN LIEU OF ANY OTHER WARRANTIES, EXPRESS OR IMPLIED, INCLUDING BUT NOT LIMITED TO WARRANTY OF MERCHANTABILITY OR WARRANTY OF FITNESS FOR A PARTICULAR PURPOSE.

Graco's sole obligation and buyer's sole remedy for any breach of warranty shall be as set forth above. The buyer agrees that no other remedy (including, but not limited to, incidental or consequential damages for lost profits, lost sales, injury to person or property, or any other incidental or consequential loss) shall be available. Any action for breach of warranty must be brought within two (2) years of the date of sale.

GRACO MAKES NO WARRANTY, AND DISCLAIMS ALL IMPLIED WARRANTIES OF MERCHANTABILITY AND FITNESS FOR A PARTICULAR PURPOSE, IN CONNECTION WITH ACCESSORIES, EQUIPMENT, MATERIALS OR COMPONENTS SOLD BUT NOT MANUFACTURED BY GRACO. These items sold, but not manufactured by Graco (such as electric motors, switches, hose, etc.), are subject to the warranty, if any, of their manufacturer. Graco will provide purchaser with reasonable assistance in making any claim for breach of these warranties.

In no event will Graco be liable for indirect, incidental, special or consequential damages resulting from Graco supplying equipment hereunder, or the furnishing, performance, or use of any products or other goods sold hereto, whether due to a breach of contract, breach of warranty, the negligence of Graco, or otherwise.

FOR GRACO CANADA CUSTOMERS

The Parties acknowledge that they have required that the present document, as well as all documents, notices and legal proceedings entered into, given or instituted pursuant hereto or relating directly or indirectly hereto, be drawn up in English. Les parties reconnaissent avoir convenu que la rédaction du présente document sera en Anglais, ainsi que tous documents, avis et procédures judiciaires exécutés, donnés ou intentés, à la suite de ou en rapport, directement ou indirectement, avec les procédures concernées.

Graco Information

For the latest information about Graco products, visit www.graco.com.

To place an order, contact your Graco Distributor or call to identify the nearest distributor.

Phone: 612-623-6921 **or Toll Free:** 1-800-328-0211 **Fax:** 612-378-3505

All written and visual data contained in this document reflects the latest product information available at the time of publication.

Graco reserves the right to make changes at any time without notice.

For patent information, see www.graco.com/patents.

Original Instructions. This manual contains English. MM 3A3465

Graco Headquarters: Minneapolis

International Offices: Belgium, China, Japan, Korea

GRACO INC. AND SUBSIDIARIES • P.O. BOX 1441 • MINNEAPOLIS MN 55440-1441 • USA

Copyright 2016, Graco Inc. All Graco manufacturing locations are registered to ISO 9001.

www.graco.com
Revision A, March 2016