

Hydra-Cat[®] Proportioners

310796G

EN

**For fixed ratio proportioning of 2-component reactive materials. For professional use only.
Not for use in explosive atmospheres.**



Important Safety Instructions

Read all warnings and instructions in this manual. Save these instructions.

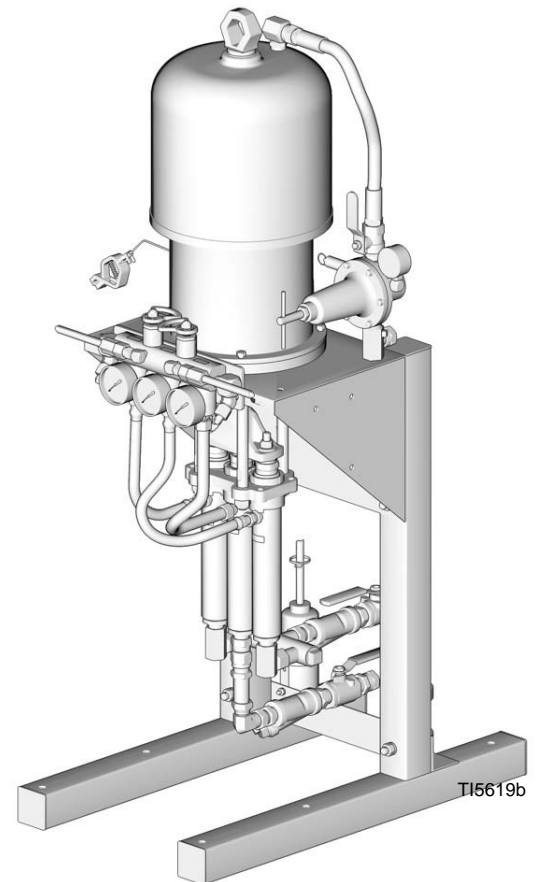
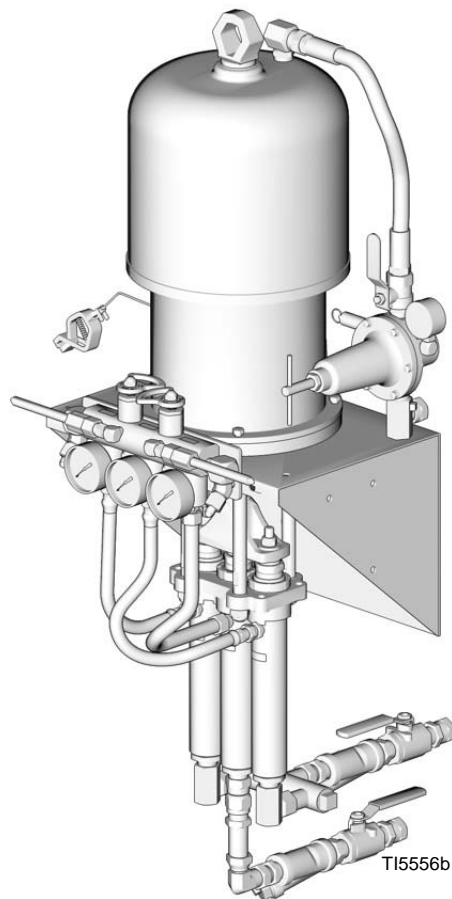

See page 4 for model information, including maximum working pressure.



Contents

Manual Conventions	3	Repair	13
Isocyanate Hazard	3	Air Motor	13
Keep Resin and Hardener Separate	3	Displacement Pump	14
Models	4	Fluid Manifold	16
Hydra-Cat® Proportioners	4	Parts	18
King® Proportioning Pumps	4	Stand Mount Proportioners	18
Related Manuals	5	Wall Mount Proportioners.....	20
Warnings	6	Proportioner Pumps	22
Pressure Relief Procedure	8	248779 Fluid Manifold	24
Alternate Pressure Relief Procedure	9	248780 Fluid Manifold	24
Troubleshooting	10	241693 Stand Kit	26
		Technical Data	27
		Graco Standard Warranty	28
		Graco Information	28

Manual Conventions





 WARNING
 Hazard Symbol
<p>WARNING: a potentially hazardous situation which, if not avoided, could result in death or serious injury.</p> <p>Warnings in the instructions usually include a symbol indicating the hazard. Read the general Warnings section for additional safety information.</p>

CAUTION
<p>CAUTION: a potentially hazardous situation which, if not avoided, may result in property damage or destruction of equipment.</p>

Note

 Additional helpful information.

Isocyanate Hazard

						
<p>Spraying materials containing isocyanates creates potentially harmful mists, vapors, and atomized particulates.</p> <p>Read material manufacturer's warnings and material MSDS to know specific hazards and precautions related to isocyanates.</p> <p>Prevent inhalation of isocyanate mists, vapors, and atomized particulates by providing sufficient ventilation in the work area. If sufficient ventilation is not available, a supplied-air respirator is required for everyone in the work area.</p> <p>To prevent contact with isocyanates, appropriate personal protective equipment, including chemically impermeable gloves, boots, aprons, and goggles, is also required for everyone in the work area.</p>						

Keep Resin and Hardener Separate

CAUTION
<p>To prevent cross-contamination of the wetted parts, do not interchange resin and hardener parts. Keep parts separate when cleaning the manifold. The manifold is shipped with the resin (high volume) side on the left and the hardener (low volume) side on the right.</p> <p>Never leave hardener (isocyanate) wetted parts exposed to moisture in the air.</p>

Models

Hydra-Cat[®] Proportioners

Part No., Series	Maximum Working Fluid Pressure psi (MPa, bar)	Maximum Air Input Pressure psi (MPa, bar)	Volume Ratio	Description	Includes:	
					Pump	Fluid Manifold
234931, A	5000 (34.5, 345)	70 (0.43, 4.3)	1:1	Stand Mount Proportioner	234921	248780
234932, A	4600 (31.7, 317)	100 (0.7, 7.0)	2:1	Stand Mount Proportioner	234922	248779
234933, A	5000 (34.5, 345)	100 (0.7, 7.0)	3:1	Stand Mount Proportioner	234923	248779
234934, A	5000 (34.5, 345)	90 (0.62, 6.2)	4:1	Stand Mount Proportioner	234924	248779
234991, A	5000 (34.5, 345)	70 (0.43, 4.3)	1:1	Wall Mount Proportioner	234921	248780
234992, A	4600 (31.7, 317)	100 (0.7, 7.0)	2:1	Wall Mount Proportioner	234922	248779
234993, A	5000 (34.5, 345)	100 (0.7, 7.0)	3:1	Wall Mount Proportioner	234923	248779
234994, A	5000 (34.5, 345)	90 (0.62, 6.2)	4:1	Wall Mount Proportioner	234924	248779

King[®] Proportioning Pumps

Pump Part No., Series	Maximum Working Fluid Pressure psi (MPa, bar)	Maximum Air Input Pressure psi (MPa, bar)	Pressure Ratio	Fluid Flow at 40 cpm gpm (lpm)
234921, A	5000 (34.5, 345)	70 (0.43, 4.3)	68:1	1.8 (6.8)
234922, A	4600 (31.7, 317)	100 (0.7, 7.0)	46:1	2.7 (10.0)
234923, A	5000 (34.5, 345)	100 (0.7, 7.0)	50:1	2.4 (9.0)
234924, A	5000 (34.5, 345)	90 (0.62, 6.2)	54:1	2.3 (8.7)

Related Manuals





Refer to these manuals for detailed equipment information. Manuals are available at www.graco.com.

Proportioning System	
Part No.	Description
310794	Proportioning System, Instructions-Parts Manual (English)
310858	Proportioning System, Instructions-Parts Manual (Spanish)
Hydra-Cat Proportioner	
310795	Hydra-Cat Proportioner, Operation Manual (English)
310859	Hydra-Cat Proportioner, Operation Manual (Spanish)
310796	Hydra-Cat Proportioner, Repair-Parts Manual (English)
310860	Hydra-Cat Proportioner, Repair-Parts Manual (Spanish)
Displacement Pumps	
307944	Instruction Manual (English)
King Air Motor	
309347	Instruction Manual (English)
Remote Mix Manifold Kit	
310797	Instruction Manual (English)
Heated Hose Control	
310798	Instruction Manual (English)
Heated Hose	
309572	Instruction Manual (English)
Feed Pump Kit	
310863	Instruction Manual (English)
Solvent Flush Pump Kit	
310863	Instruction Manual (English)
Agitator Kit	
310863	Instruction Manual (English)
Circulation and Return Tube Kits	
309852	Instruction Manual (English)

Air Supply Kit	
309827	Instruction Manual (English)
Air Regulator	
308167	Instruction Manual (English)
Airless Spray Gun	
309741	Instruction Manual (multilingual)

Warnings

The following warnings include general safety information for this equipment. Further product specific warnings may be included in the text where applicable.

 WARNING	
	<p>FIRE AND EXPLOSION HAZARD</p> <p>Flammable fumes, such as solvent and paint fumes, in work area can ignite or explode. To help prevent fire and explosion:</p> <ul style="list-style-type: none"> • Use equipment only in well ventilated area. • Eliminate all ignition sources; such as pilot lights, cigarettes, portable electric lamps, and plastic drop cloths (potential static arc). • Keep work area free of debris, including solvent, rags and gasoline. • Do not plug or unplug power cords, or turn power or light switches on or off when flammable fumes are present. • Ground equipment and conductive objects in work area. See Grounding instructions. • Use only grounded hoses. • Hold gun firmly to side of grounded pail when triggering into pail. • If there is static sparking or you feel a shock, stop operation immediately. Do not use equipment until you identify and correct the problem. • Keep a fire extinguisher in the work area.
	<p>SKIN INJECTION HAZARD</p> <p>High-pressure fluid from gun, hose leaks, or ruptured components will pierce skin. This may look like just a cut, but it is a serious injury that can result in amputation. Get immediate surgical treatment.</p> <ul style="list-style-type: none"> • Do not point gun at anyone or at any part of the body. • Do not put your hand over the spray tip. • Do not stop or deflect leaks with your hand, body, glove, or rag. • Do not spray without tip guard and trigger guard installed. • Engage trigger lock when not spraying. • Follow Pressure Relief Procedure in this manual, when you stop spraying and before cleaning, checking, or servicing equipment.
	<p>EQUIPMENT MISUSE HAZARD</p> <p>Misuse can cause death or serious injury.</p> <ul style="list-style-type: none"> • Do not exceed the maximum working pressure or temperature rating of the lowest rated system component. See Technical Data in all equipment manuals. • Use fluids and solvents that are compatible with equipment wetted parts. See Technical Data in all equipment manuals. Read fluid and solvent manufacturer's warnings. • Check equipment daily. Repair or replace worn or damaged parts immediately. • Do not alter or modify equipment. • For professional use only. • Use equipment only for its intended purpose. Call your Graco distributor for information. • Route hoses and cables away from traffic areas, sharp edges, moving parts, and hot surfaces. • Do not kink or over bend hoses or use hoses to pull equipment. • Comply with all applicable safety regulations.
	<p>MOVING PARTS HAZARD</p> <p>Moving parts can pinch or amputate fingers and other body parts.</p> <ul style="list-style-type: none"> • Keep clear of moving parts. • Do not operate equipment with protective guards or covers removed. • Pressurized equipment can start without warning. Before checking, moving, or servicing equipment, follow the Pressure Relief Procedure in this manual. Disconnect power or air supply.

**WARNING****TOXIC FLUID OR FUMES HAZARD**

Toxic fluids or fumes can cause serious injury or death if splashed in the eyes or on skin, inhaled, or swallowed.

- Read MSDS's to know the specific hazards of the fluids you are using.
- Store hazardous fluid in approved containers, and dispose of it according to applicable guidelines.

**PERSONAL PROTECTIVE EQUIPMENT**

You must wear appropriate protective equipment when operating, servicing, or when in the operating area of the equipment to help protect you from serious injury, including eye injury, inhalation of toxic fumes, burns, and hearing loss. This equipment includes but is not limited to:



- Protective eyewear
- Clothing and respirator as recommended by the fluid and solvent manufacturer
- Gloves
- Hearing protection

Pressure Relief Procedure

 If your system includes Circulation and Return Tube Kit 246978 (see manual 309852), see **Alternate Pressure Relief Procedure**, page 9.

 **WARNING**



Follow **Pressure Relief Procedure** when you stop spraying and before cleaning, checking, servicing, or transporting equipment. Read warnings, page 6.

1. Engage trigger lock.

 Trigger lock may vary, depending on gun.



TI5660a

2. If your system uses heaters, shut off the main power to the heaters and heated hose control, and circulate the fluid for at least 10 minutes to cool the heated fluid and heaters.

3. Shut off the feed pump and proportioning pump air regulators and bleed-type master air valves.



TI5653a

4. Disengage trigger lock.



TI5659a

5. Hold a metal part of the gun firmly to a grounded metal pail. Trigger the gun to relieve pressure.



TI5662a

6. Engage trigger lock.



TI5660a

continued on page 9.

7. Flush mix manifold, hoses, and gun, see manual 310797. Shut off solvent supply pump and repeat steps 4-6 to relieve solvent pressure.

8. If you suspect the spray tip or hose is clogged or that pressure has not been fully relieved after following the steps above, **very slowly** loosen tip guard retaining nut or hose end coupling to relieve pressure gradually, then loosen completely. Clear hose or tip obstruction.

9. If static mixer, whip hose, and gun cannot be flushed because of mixed and cured material, **very slowly** loosen static mixer tube from mix manifold outlet to relieve pressure gradually, then loosen completely. Replace or clean clogged components.

2. Turn SPRAY/PRESSURE RELIEF valves to PRES-SURE RELIEF (hardener valve must be opened first).

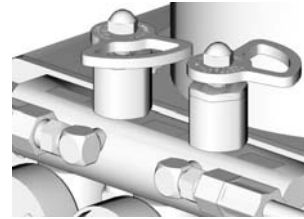

TI5657a

Alternate Pressure Relief Procedure



Use this procedure if your system includes Circulation and Return Tube Kit 246978 (see manual 309852), to relieve fluid pressure back to the supply drums. This method allows:

- fluid pressure relief without flushing the mixer, hose, and gun again

- circulation back to drums after a drum change, to purge air from feed pumps and lines

- if using drum heaters, warm material may be circulated through proportioner before beginning to spray.

CAUTION
Do not circulate contaminated material back to the drums.

1. Follow steps 1-6 under **Pressure Relief Procedure**, page 8.

Troubleshooting

Problem	Cause	Solution
System stops or will not start.	Air pressure or volume too low.	Increase; check air compressor.
	Closed or restricted air line or air valve.	Open or clean.
	Fluid valves closed.	Open.
	Clogged fluid hose.	Replace.
	Air motor worn or damaged.	Repair air motor; see 309347.
	Displacement pump stuck.	Repair pump; see 307944.
System speeds up or runs erratically.	Fluid containers are empty.**	Check often; keep filled.
	Air in fluid lines.**	Purge; check connections.
	Displacement pump parts worn or damaged.	Repair pump; see 307944.
Pump operates, but resin output pressure drops on upstroke.*	Dirty, worn, or damaged resin pump piston valve or piston packings.	Clean, repair pump; see 307944.
Pump operates, but resin output pressure drops on downstroke.	Dirty, worn, or damaged resin pump intake valve.	Clean, repair pump; see 307944.
Pump operates, but resin output pressure drops on both strokes.*	Hardener output restriction.	Clean, unplug hardener side.
	Fluid supply low.**	Refill or change container.
Pump operates, but hardener output pressure drops on upstroke.*	Dirty, worn, or damaged hardener pump piston valve or piston packings.	Clean, repair pump; see 307944.
Pump operates, but hardener output pressure drops on downstroke.*	Dirty, worn, or damaged hardener pump intake valve.	Clean, repair pump; see 307944.
Pump operates, but hardener output pressure drops on both strokes.	Resin output restriction.	Clean, unplug resin side.
	Fluid supply low.**	Refill or change container.
Fluid leak around packing nut.	Loose packing nut or worn throat packings.	Tighten; replace; see 307944.
Relief valve opens too soon or will not close.	Relief valve is dirty or damaged.	Replace valve cartridge (209) with kit 246842.
No pressure on one side; fluid leaking from fluid manifold.	Overpressure rupture disk blown.	Determine cause of overpressurization and correct. Replace rupture disk assembly (202).
Pressure and flow surges on upstroke.	Feed pressure too high. Every pound of feed pressure adds 2 psi boost during upstroke.	Reduce feed pressure. See Technical Data , page 27.
Fluid outlet pressure gauges split at top changeover (if one gauge drops, the others will rise).	Not fully loading one side on upstroke.	Increase pressure on side that dropped.
		Increase feed hose size.
		Clean inlet strainer (12a).

* Fluid ratio will be wrong.

** Purge all air from system before proportioning fluids.

Troubleshooting continued on page 11.

⚠ WARNING

 Read warnings, page 6.

1. Relieve pressure, page 8. Stop pump at bottom of its stroke before servicing.

2. Faulty fluid manifold check valves (219) can mask pump problems. Keep the check valves operating properly.
3. This chart is specific to the air motor and pump. Refer to the other supplied manuals to troubleshoot individual components.

This chart uses proportioner gauges to determine pump malfunctions. A 2 pump proportioner is shown for clarity. Observe the gauge readings during the stroke direction indicated by the bold arrow, and immediately after closing the manifold.

**TROUBLE AREA:
Resin Pump Leakage**

1. Throat packing
2. Piston packing
3. Piston ball check

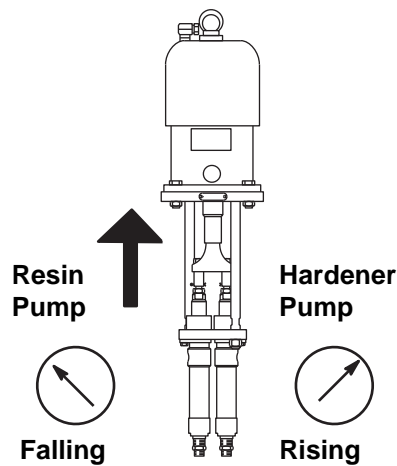

**TROUBLE AREA:
Hardener Pump Leakage**

1. Throat packing
2. Piston packing
3. Piston ball check

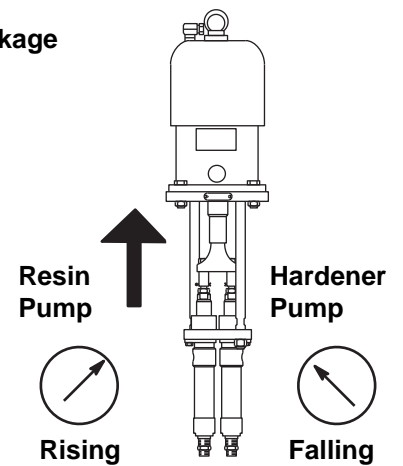

**TROUBLE AREA:
Resin Pump Leakage**

1. Throat packing
2. Intake ball check

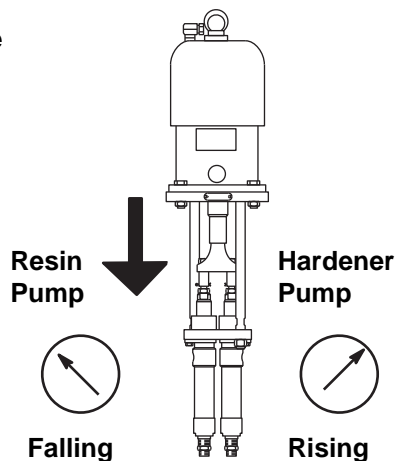

**TROUBLE AREA:
Hardener Pump Leakage**

1. Throat packing
2. Intake ball check

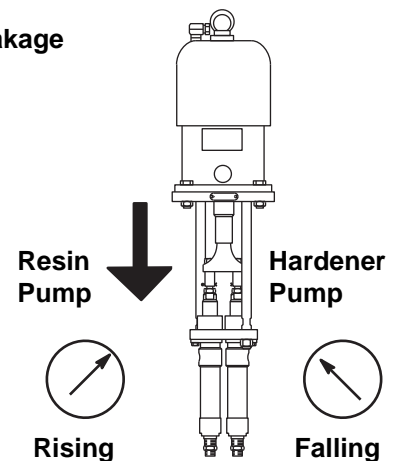

Repair

Air Motor

1. Flush before repairing equipment, if possible. See Hydra-Cat Operation manual 310795.

⚠ WARNING



Read warnings, page 6.

2. Relieve pressure, page 8. Stop pump at bottom of its stroke.
3. Remove air supply line from air motor inlet. Remove pump ground wire.



Repairing the air motor's air valve does not require removal of the motor. Stop here and see manual 309347 for air valve repair. For complete air motor repair, continue with step 4.

4. Remove screws (102) and washers (103) holding adapter plate (104) to motor (101). See FIG. 1.
5. Remove screws (115), washers (116) and nuts (117) holding pump assembly to mounting bracket.
6. Using a hoist, lift air motor (101) 4 in. (101 mm) from adapter plate (104).
7. Hold flats of coupler (105) with wrench to keep it from turning, and unscrew air motor rod (R).
8. See manual 309347 for air motor repair.
9. Reassemble in reverse order, following all assembly notes in FIG. 1.

⚠₁ Torque to 53-67 ft-lb (72-91 N•m).

⚠₂ Apply thread locking sealant to threads.

⚠₃ Torque to 200-300 ft-lb (270-405 N•m).

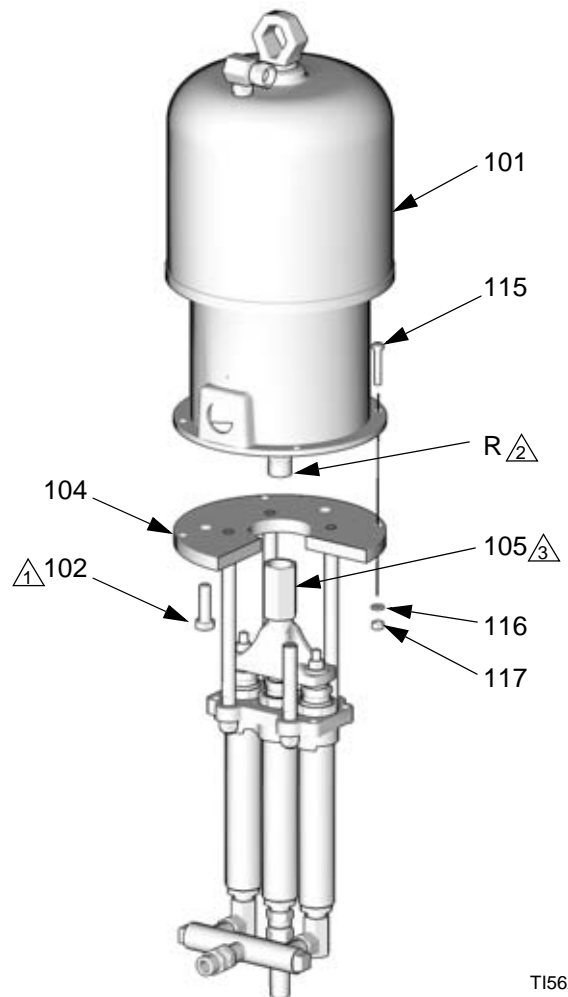

T15622a

FIG. 1. Air Motor

Displacement Pump

Disassembly

1. Flush before repairing equipment, if possible. See Hydra-Cat Operation manual 310795.

 **WARNING**



Read warnings, page 6.

2. Relieve pressure, page 8. Stop pump at bottom of its stroke.
3. Remove fluid outlet hoses (17, 18) and fittings (19, 20) from displacement pumps (110).
4. Unscrew 90° swivel unions (131) from supply manifold (130), then remove from outside displacement pumps. *On three pump models only*, unscrew swivel union (134) from center displacement pump.
5. Remove locknuts (112) from displacement rods of the two outer pumps. See FIG. 2. Unscrew the two outer locknuts (108) from the top of the tie plate (109) on the two displacement pumps. Use a punch and hammer to loosen.
6. Remove the two outer pumps from tie plate. Remove washers (107) from rods of each pump.
7. *On three pump models only*, screw center pump's displacement rod out of yoke (106), using a wrench on flats of rod. Remove pump from yoke, then remove washer (107) from pump rod.
8. See manual 307944 for displacement pump repair.

 Loosen tie rod nuts (119). Retorque tie rods (118) into plate (104) to 75-85 ft-lb (101-114 N•m), then retorque nuts (119) to 75-85 ft-lb (101-114 N•m).

Reassembly

1. *On three pump models only*, slide center displacement pump rod through tie plate (109), center locknut (108), and washer (107). Thread displacement rod into yoke (106) by turning complete cylinder. Use a wrench on flats of displacement rod for final tightening. Torque to 53-67 ft-lb (72-91 N•m). Push cylinder up into place in tie plate and torque center locknut (108) to 100-200 ft-lb (135-270 N•m).

2. Slide the outer two displacement pump rods through tie plate (109), outer locknuts (108), and washers (107). Install locknuts (112) loosely on displacement rods. Push cylinders up into place in tie plate and torque outer locknuts (108) to 100-200 ft-lb (135-270 N•m).
3. Move air motor to bottom of its stroke. Check for movement of air motor yoke at each displacement rod. With rods centered, tighten locknuts (112) securely and torque to 53-67 ft-lb (72-91 N•m).
4. Tighten throat packing nut just enough to prevent leakage, no tighter.
5. Reconnect swivel unions to the pumps. Hold intake valves steady with a wrench to prevent from turning.

- ⚠ Torque to 53-67 ft-lb (72-91 N•m).
- ⚠ Torque to 100-200 ft-lb (135-270 N•m).
- ⚠ Torque to 75-85 ft-lb (101-114 N•m).

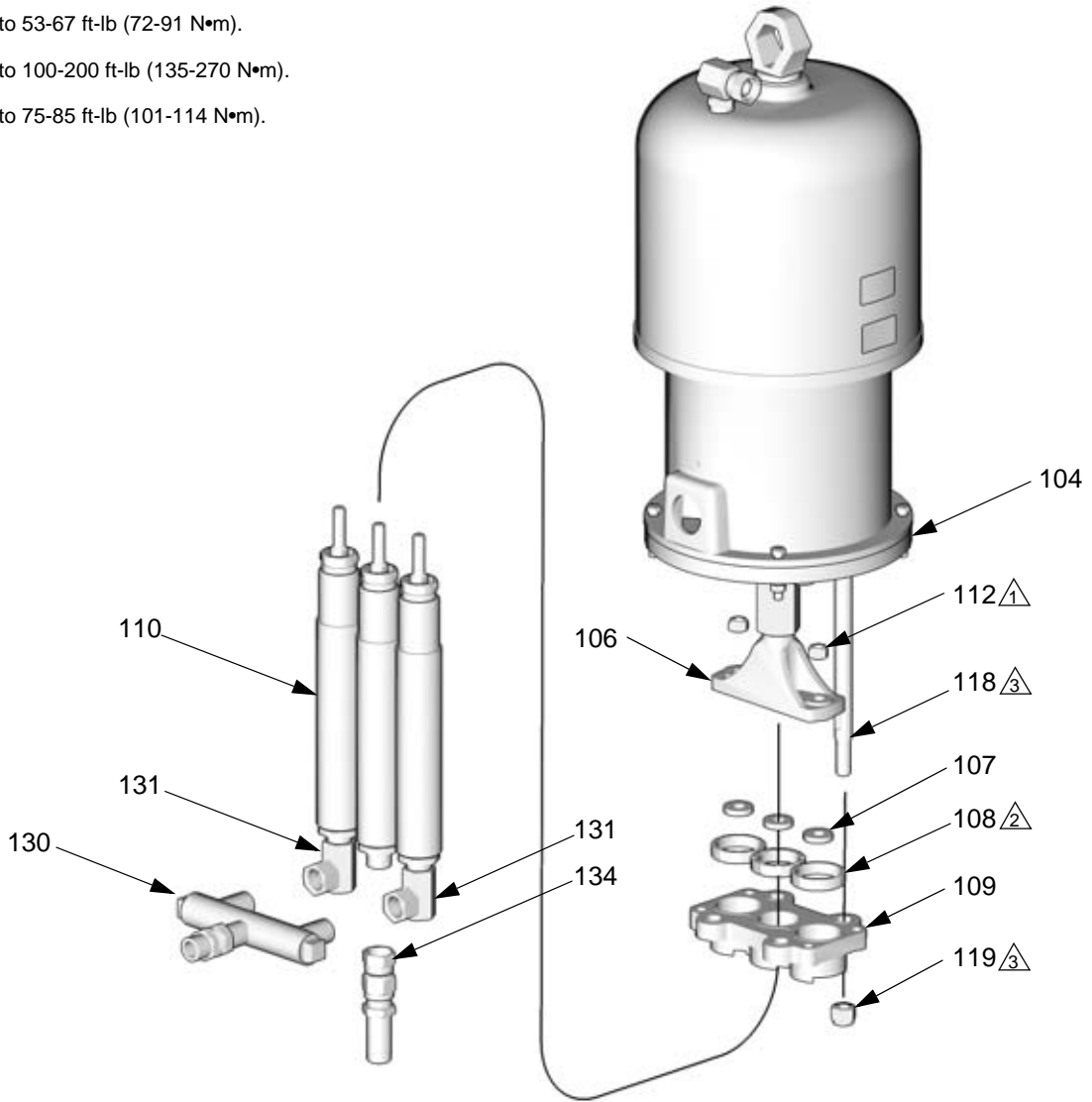

TI5623a

FIG. 2. Displacement Pumps

Fluid Manifold

1. Flush before repairing equipment, if possible. See Hydra-Cat Operation manual 310795.



2. Relieve pressure, page 8. Stop pump at bottom of its stroke.

Rupture Disks

1. Relieve pressure, page 8.
2. Remove rupture disk assembly (202) from fluid manifold (201). See FIG. 3.
3. Install new rupture disk kit. Hole in red outlet cap must face toward rear plate (215).

Check Valves

1. Relieve pressure, page 8.
2. Remove screws (204) holding check valve assembly to fluid manifold (201). See FIG. 3. Push check valve cartridge (219) out of housing from the bottom.
3. Clean or replace check valve cartridge (219). To disassemble for cleaning, insert 1/8 in. (3 mm) punch through the middle top hole and tap out ball (219a) and seat (219b). See **Check Valve (219) Detail** in FIG. 3.
4. Clean check valve bore in fluid manifold (201).
5. Reassemble check valve, coat with Part No. 118665 Grease, and install in fluid manifold (201).

Drain Valves

1. Relieve pressure, page 8. Turn valve handles to SPRAY position. See FIG. 3.
2. Remove nut (212), handle (211), and spring (210).
3. Unscrew elbow (213) from fluid manifold (201).
4. Unscrew valve (209) from fluid manifold (201). Clean and inspect for damage. Replace with kit 246842 if necessary. Add 10 drops of ISO pump oil inside spring cavity.

5. Remove seat (216) and seal (217). Clean drain valve bore in fluid manifold (201).
6. Inspect o-ring (231) and replace if necessary.
7. Install seal (217) and seat (216) in fluid manifold (201). Beveled side of seat must face up.
8. Apply sealant to valve threads and install in fluid manifold (201). Torque to 355-395 in-lb (40.1-44.6 N•m).
9. Reinstall elbow (213). Elbow outlets must face away from each other.
10. Apply sealant to threads of valve stud. Lubricate ends of spring. Install spring (210), handle (211), and nut (212). Position valve handles as shown with valves in SPRAY position, to ensure that hardener valve must be opened before resin valve. Torque nut to 175-195 in-lb (19.8-22.0 N•m).

- ⚠1 Hole in disc housing must face toward rear.
- ⚠2 Handles must be oriented as shown in SPRAY position.
- ⚠3 Beveled side must face up.
- ⚠4 Apply sealant to threads.
- ⚠5 Torque to 355-395 in-lb (40.1-44.6 N•m).
- ⚠6 Elbow outlets must face away from each other.
- ⚠7 Lubricate ends of spring.
- ⚠8 Torque to 175-195 in-lb (19.8-22.0 N•m).
- ⚠9 See **Check Valve (219) Detail**.
- ⚠10 Coat outside of check valves (219) with liberal amount of 118665 Grease.

* Parts included in Check Valve Kit 249035.

Check Valve (219) Detail

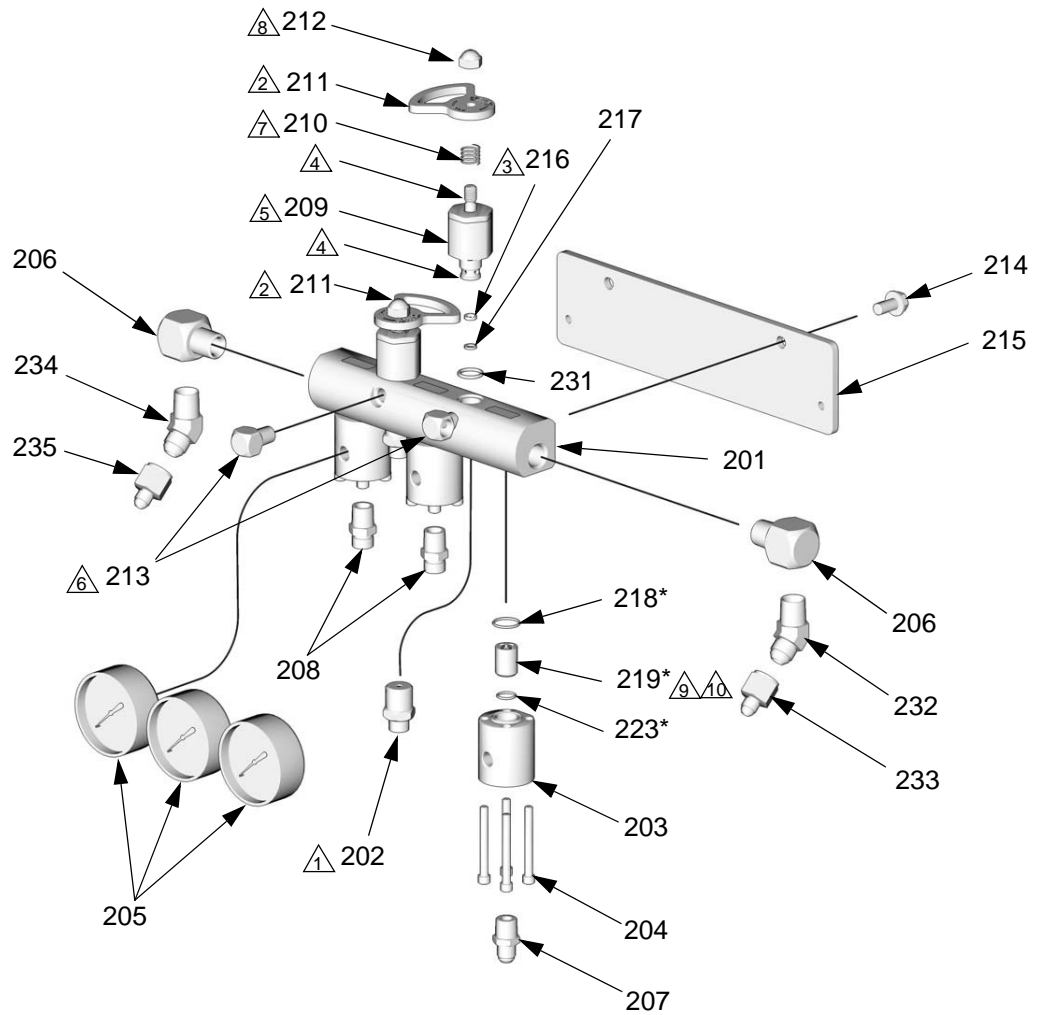
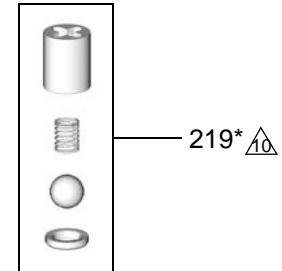

TI5626b

FIG. 3. Fluid Manifold

Parts

Stand Mount Proportioners

234931 Series A, 1:1 Mix Ratio

234932 Series A, 2:1 Mix Ratio

234933 Series A, 3:1 Mix Ratio

234934 Series A, 4:1 Mix Ratio

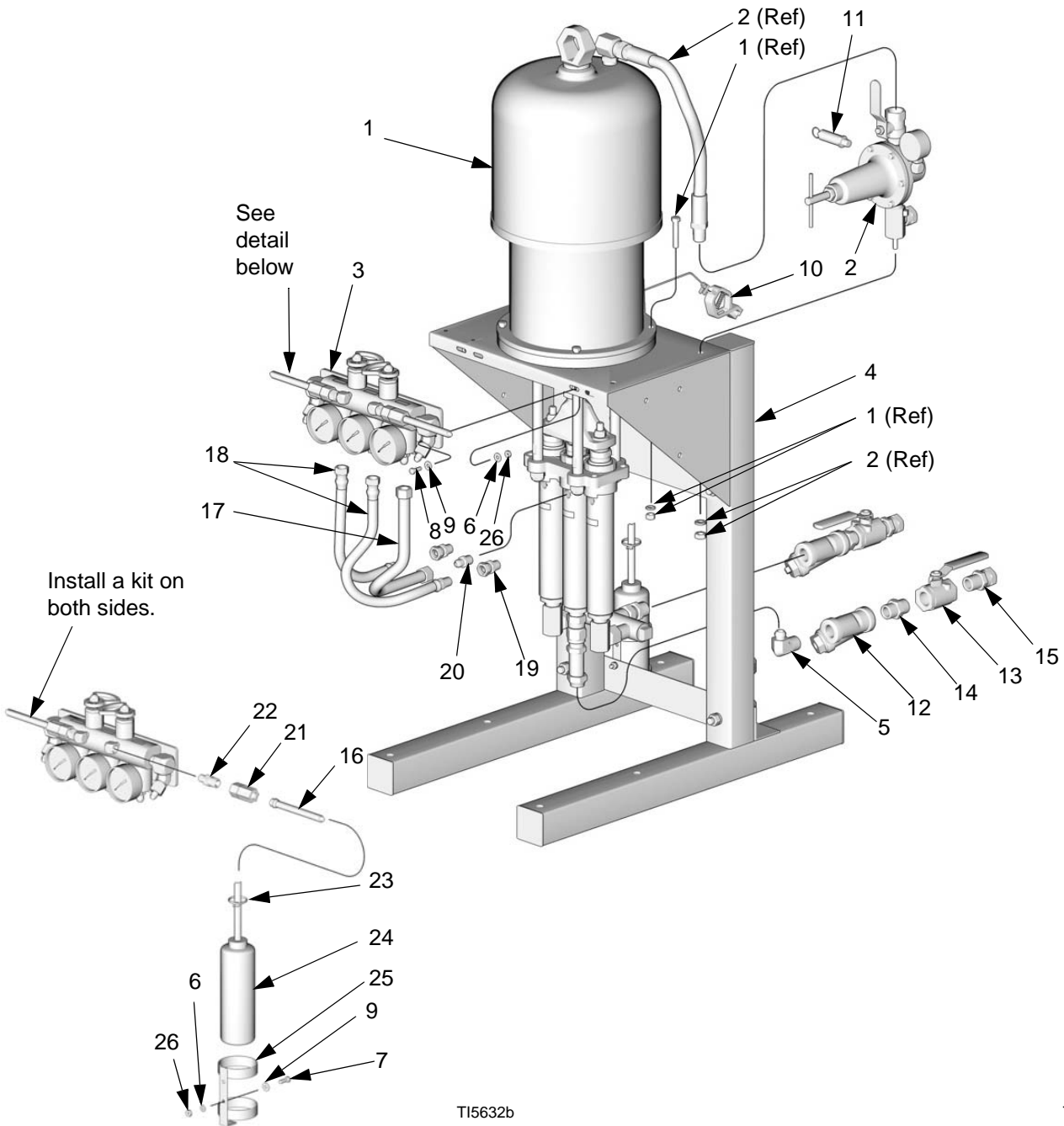

T15632b

T15620b

Stand Mount Proportioners

234931 Series A, 1:1 Mix Ratio

234932 Series A, 2:1 Mix Ratio

234933 Series A, 3:1 Mix Ratio

234934 Series A, 4:1 Mix Ratio

Ref. No.	Part No.	Description	Qty.	Ref. No.	Part No.	Description	Qty.
1	234921	PUMP, proportioner; 234931; see page 22	1	19	155665	UNION, adapter; 3/8 npt(m) x 3/8 npsm(f); 234931 only	1
	234922	PUMP, proportioner; 234932; see page 22	1		155665	UNION, adapter; 3/8 npt(m) x 3/8 npsm(f); 234932, 234933, and 234934	2
	234923	PUMP, proportioner; 234933; see page 22	1	20	112100	ADAPTER; 3/8 npt(m) x 9/16-18 unf-2a	1
	234924	PUMP, proportioner; 234934; see page 22	1	21	205439	COUPLING; 3/8 npsm(f) x 3/8 in. (10 mm) ID tube	2
2	207651	KIT, air regulator; see 308168	1	22	165198	NIPPLE, reducing; 3/8 npt x 1/4 npt	2
3	248780	MANIFOLD, fluid, two pump; 234931 only; see page 24	1	23	112278	WRAP, tie	2
	248779	MANIFOLD, fluid, three pump; 234932, 234933, and 234934; see page 24	1	24	112279	BOTTLE	2
				25	236272	HOLDER, bottle	2
				26	100015	NUT, hex; 1/4-20	4
4	241693	KIT, stand; see page 26	1				
5	160327	ELBOW, swivel; 3/4 npt(m) x 3/4 npsm(f)	2				
6	100016	WASHER, lock; 1/4	4				
7	100022	SCREW, cap, hex hd; 1/4-20 x 3/4 in. (19 mm)	2				
8	100021	SCREW, cap, hex hd; 1/4-20 x 1 in. (25 mm)	2				
9	110755	WASHER, plain	6				
10	244524	GROUND WIRE	1				
11	108124	VALVE, safety relief; 234931 only	1				
	103347	VALVE, safety relief; 234932, 234933, and 234934	1				
12	101078	Y-STRAINER; includes item 12a	2				
12a	26A349	KIT, filter, replacement (2 pack)	1				
	26A350	KIT, filter, replacement (10 pack)	1				
13	109077	VALVE, ball; 3/4 npt (fbc)	2				
14	C20487	NIPPLE; 3/4 npt	2				
15	157785	UNION, swivel; 3/4 npt(m) x 3/4 npsm(f)	2				
16	190738	TUBE; nylon; 3/8 in. (10 mm) ID; 1/2 in. (13 mm) OD; 36 in. (915 mm)	2				
17	15E601	HOSE, hardener; PTFE, braided sst; 16-1/2 in. (419 mm)	1				
18	198847	HOSE, resin; 3/8 npt(m) x 3/8 npsm(f); 3/8 in. (10 mm) ID; nylon, with steel braid; 13 in. (330 mm); 234931 only	1				
	198847	HOSE, resin; 3/8 npt(m) x 3/8 npsm(f); 3/8 in. (10 mm) ID; nylon, with steel braid; 13 in. (330 mm); 234932, 234933, and 234934	2				

Wall Mount Proportioners

234991 Series A, 1:1 Mix Ratio

234992 Series A, 2:1 Mix Ratio

234993 Series A, 3:1 Mix Ratio

234994 Series A, 4:1 Mix Ratio

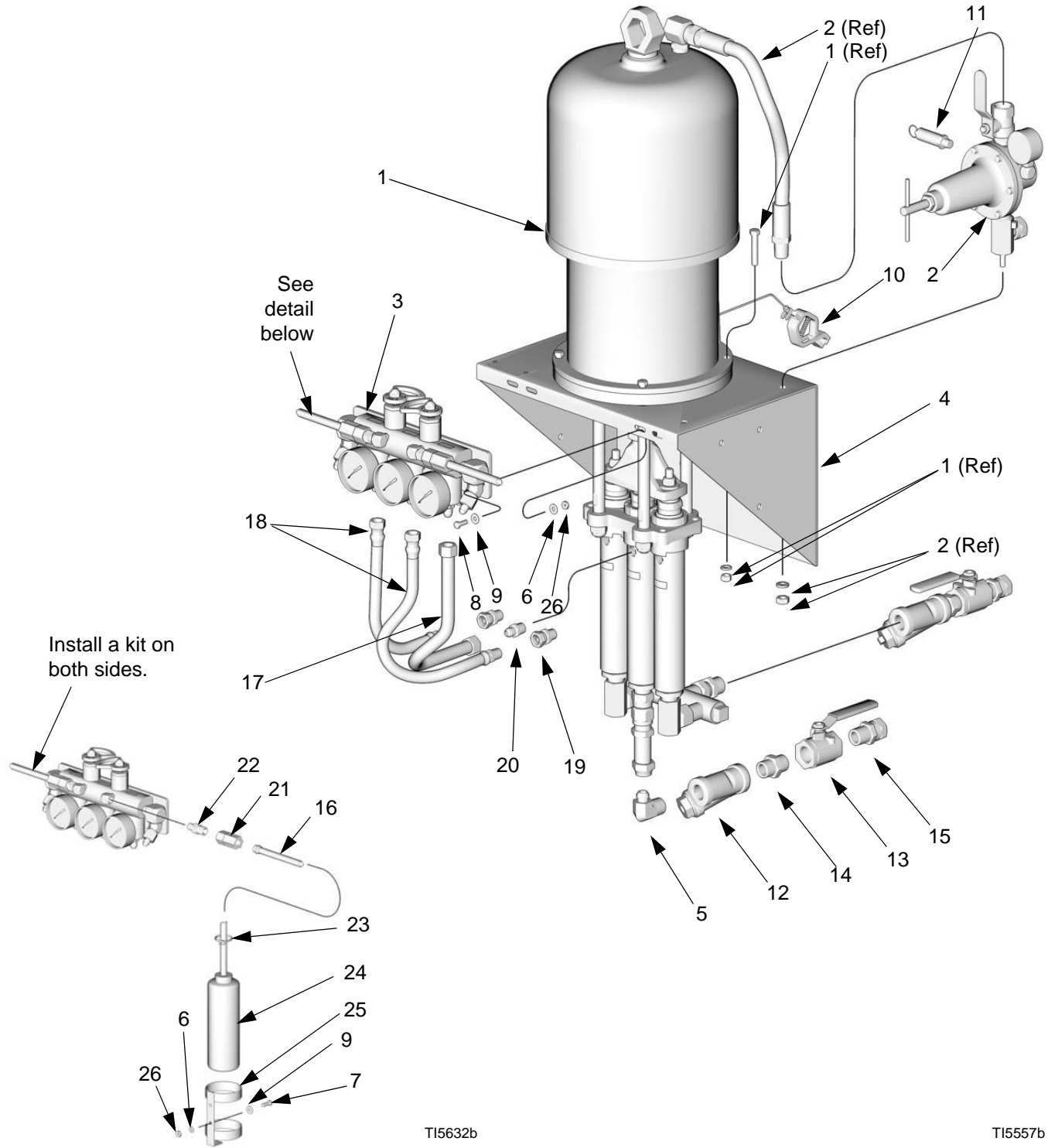

Wall Mount Proportioners

234991 Series A, 1:1 Mix Ratio

234992 Series A, 2:1 Mix Ratio

234993 Series A, 3:1 Mix Ratio

234994 Series A, 4:1 Mix Ratio

Ref. No.	Part No.	Description	Qty.	Ref. No.	Part No.	Description	Qty.
1	234921	PUMP, proportioner; 234991; see page 22	1	19	155665	UNION, adapter; 3/8 npt(m) x 3/8 npsm(f); 234991 only	1
	234922	PUMP, proportioner; 234992; see page 22	1		155665	UNION, adapter; 3/8 npt(m) x 3/8 npsm(f); 234992, 234993, and 234994	2
	234923	PUMP, proportioner; 234993; see page 22	1	20	112100	ADAPTER; 3/8 npt(m) x 9/16-18 unf-2a	1
	234924	PUMP, proportioner; 234994; see page 22	1	21	205439	COUPLING; 3/8 npsm(f) x 3/8 in. (10 mm) ID tube	2
2	207651	KIT, air regulator; see 308168	1	22	165198	NIPPLE, reducing; 3/8 npt x 1/4 npt	2
3	248780	MANIFOLD, fluid, two pump; 234991 only; see page 24	1	23	112278	WRAP, tie	2
	248779	MANIFOLD, fluid, three pump; 234992, 234993, and 234994; see page 24	1	24	112279	BOTTLE	2
				25	236272	HOLDER, bottle	2
				26	100015	NUT, hex; 1/4-20	4
4	236061	BRACKET, mounting	1				
5	160327	ELBOW, swivel; 3/4 npt(m) x 3/4 npsm(f)	2				
6	100016	WASHER, lock; 1/4	4				
7	100022	SCREW, cap, hex hd; 1/4-20 x 3/4 in. (19 mm)	2				
8	100021	SCREW, cap, hex hd; 1/4-20 x 1 in. (25 mm)	2				
9	110755	WASHER, plain	6				
10	244524	GROUND WIRE	1				
11	108124	VALVE, safety relief; 234991 only	1				
	103347	VALVE, safety relief; 234992, 234993, and 234994	1				
12	101078	Y-STRAINER; includes item 12a	2				
12a	26A349	KIT, filter, replacement (2 pack)	1				
	26A350	KIT, filter, replacement (10 pack)	1				
13	109077	VALVE, ball; 3/4 npt (fbc)	2				
14	C20487	NIPPLE; 3/4 npt	2				
15	157785	UNION, swivel; 3/4 npt(m) x 3/4 npsm(f)	2				
16	190738	TUBE; nylon; 3/8 in. (10 mm) ID; 1/2 in. (13 mm) OD; 36 in. (915 mm)	2				
17	15E601	HOSE, hardener; PTFE, with steel braid; 16-1/2 in. (419 mm)	1				
18	198847	HOSE, resin; 3/8 npt(m) x 3/8 npsm(f); 3/8 in. (10 mm) ID; nylon, with steel braid; 13 in. (330 mm); 234991 only	1				
	198847	HOSE, resin; 3/8 npt(m) x 3/8 npsm(f); 3/8 in. (10 mm) ID; nylon, with steel braid; 13 in. (330 mm); 234992, 234993, and 234994	2				

Proportioner Pumps

234921 Series A, 1:1 Mix Ratio, with two displacement pumps

234922 Series A, 2:1 Mix Ratio, with three displacement pumps

234923 Series A, 3:1 Mix Ratio, with three displacement pumps

234924 Series A, 4:1 Mix Ratio, with three displacement pumps

△1 Center pump is not used on Model 234921.

△2 Attach labels 113 (hardener) and 121 (resin) below fluid outlet of appropriate pump(s).

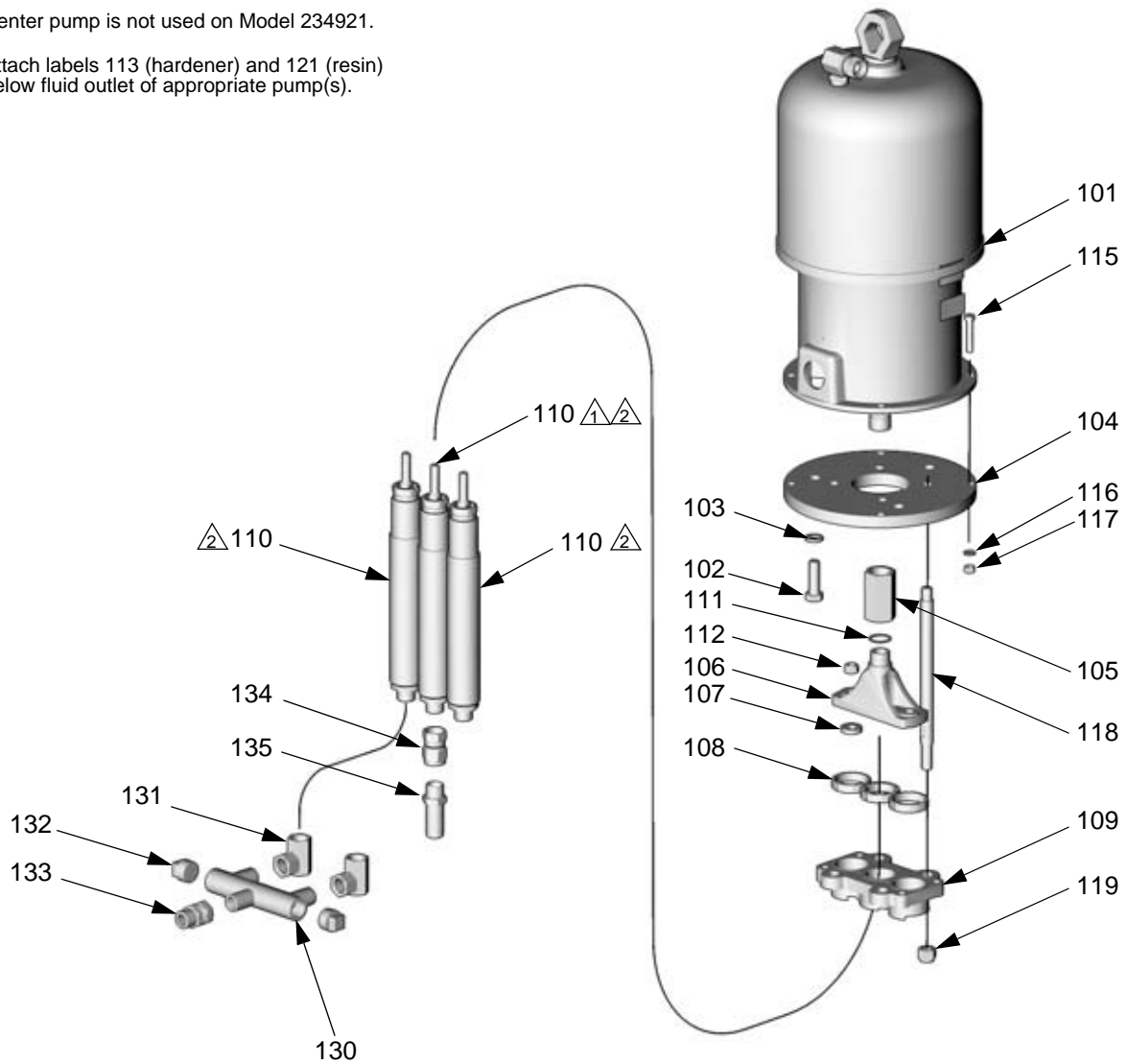

TI5511a

Proportioner Pumps

234921 Series A, 1:1 Mix Ratio, with two displacement pumps

234922 Series A, 2:1 Mix Ratio, with three displacement pumps

234923 Series A, 3:1 Mix Ratio, with three displacement pumps

234924 Series A, 4:1 Mix Ratio, with three displacement pumps

Ref. No.	Part No.	Description	Qty.	Ref. No.	Part No.	Description	Qty.
101	245111	MOTOR, air, King; see 309347	1	115	100468	SCREW, cap, hex hd; 3/8-16 x 2 in. (51 mm)	4
102	100428	SCREW, cap, hex hd; 5/8-11 x 2 in. (51 mm)	3	116	100133	WASHER, lock; 3/8	4
103	100128	WASHER, lock; 5/8	3	117	100307	NUT, hex; 3/8-16	4
104	171122	PLATE, adapter	1	118	168455	ROD, tie	4
105	172726	COUPLER	1	119	101712	NUT, lock; 5/8-11	4
106	164414	YOKE, connecting tube	1	121▲	188975	LABEL, resin	2
107	164416	WASHER, flat; 234921 only	2	130	208334	MANIFOLD; 1 in. npt(f) run; 3/4 npt(f) branches; 234922, 234923, 234924 only	1
	164416	WASHER, flat; 234922, 234923, and 234924	3	131	156589	UNION, adapter, 90°; 3/4 npt(f) x 3/4 npsm(f)	2
108	164417	NUT, lock, pump	2	132	100345	PLUG, pipe; 1 in. npt	2
109	164413	PLATE, tie	1	133	157785	SWIVEL; 3/4 npt(m) x 3/4 npsm(f)	1
110	see table	PUMP, displacement; 234921 only; see 307944	2	134	156172	UNION, swivel; 3/4 npt(f) x 3/4 npsm(f)	1
	see table	PUMP, displacement; 234922, 234923, 234924 only; see 307944	3	135	157129	NIPPLE; 3/4 npt	1
111	150429	GASKET, copper	1	▲ Replacement Danger and Warning labels, tags, and cards are available at no cost.			
112	101926	NUT, lock; 1/2-20	2				
113▲	188974	LABEL, hardener	1				

Ref. No.110 Displacement Pump Table

Model	Left Pump			Center Pump			Right Pump		
	Pump Part No.	Description	Qty	Pump Part No.	Description	Qty	Pump Part No.	Description	Qty
234921	222012	Resin (A) Pump	1	Not Used			222012	Hardener (B) Pump	1
234922	222012	Resin (A) Pump	1	222012	Hardener (B) Pump	1	222012	Resin (A) Pump	1
234923	222012	Resin (A) Pump	1	222017	Hardener (B) Pump	1	222012	Resin (A) Pump	1
234924	222012	Resin (A) Pump	1	222019	Hardener (B) Pump	1	222012	Resin (A) Pump	1

248779 Fluid Manifold, 3 pump; includes items 201-223, 231-235 (shown)

248780 Fluid Manifold, 2 pump; includes items 201-235

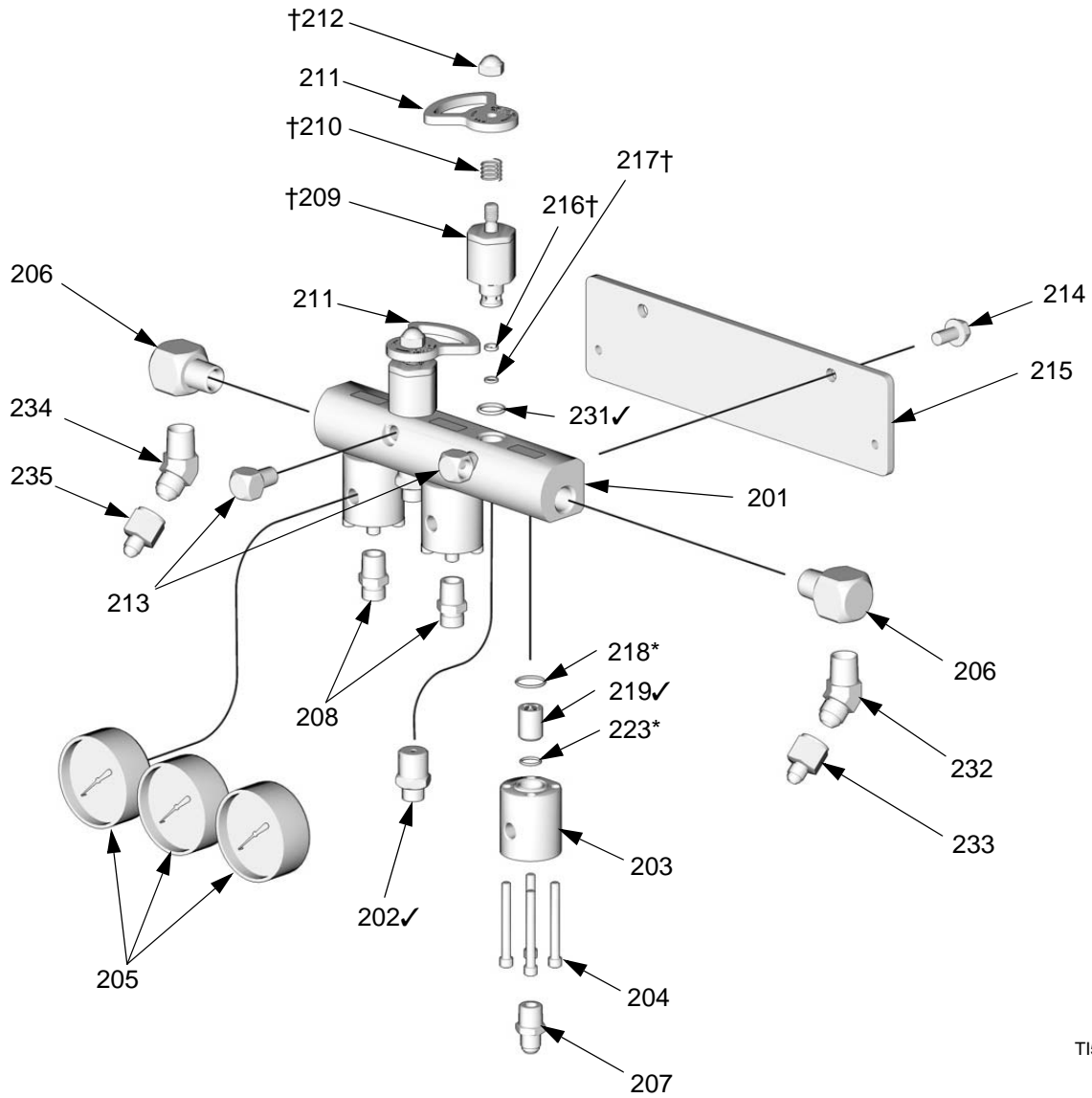

T15626b

248779 Fluid Manifold, 3 pump; includes items 201-223, 231-235 (shown)**248780 Fluid Manifold, 2 pump; includes items 201-235**

Ref. No.	Part No.	Description	Qty.
201	15E152	MANIFOLD, fluid	1
202✓	248187	HOUSING, rupture disk	2
203	15E182	HOUSING, check valve; 248779	3
	15E182	HOUSING, check valve; 248780	2
204	C19817	SCREW, cap, socket hd; 1/4-20 x 2-1/4 in. (57 mm); 248779	12
	C19817	SCREW, cap, socket hd; 1/4-20 x 2-1/4 in. (57 mm); 248780	8
205	114434	GAUGE, pressure, fluid; 248779	3
	114434	GAUGE, pressure, fluid; 248780	2
206	158683	ELBOW; 1/2 npt (m x f)	2
207	112100	ADAPTER; 3/8 npt(m) x 9/16-18 unf-2a	1
208	162485	NIPPLE; 3/8 npt x 3/8 npsm; 248779	2
	162485	NIPPLE; 3/8 npt x 3/8 npsm; 248780	1
209†	255377	VALVE, drain, cartridge	2
210†	114708	SPRING	2
211	15E181	HANDLE, valve, interlocking	2
212†	116424	NUT, cap; 3/8-16	2
213	100840	ELBOW, street; 1/4 npt (m x f)	2
214	112395	SCREW, cap, flange hd; 3/8-16 x 3/4 in. (19 mm)	2
215	15E144	PLATE, mounting, manifold	1
216†	193709	SEAT, valve	2
217†	193710	SEAL, seat; nylon	2
218*	110135	O-RING; TFE	3
219✓	249035	CHECK VALVE; 248779	3
	249035	CHECK VALVE; 248780	2
223*	104319	O-RING; TFE; 248779	3
	104319	O-RING; TFE; 248780	2
229	112166	SCREW, cap, socket hd; 1/4-20 x 3/4 in. (19 mm); 248780 only (not shown)	4
230	15E183	PLUG, manifold; 248780 only (not shown)	1
231✓	158674	O-RING; buna-N	2
232	117556	NIPPLE; #8 JIC x 1/2 npt	1
233	117502	REDUCER; #5 JIC x #8 JIC	1
234	117557	NIPPLE; #10 JIC x 1/2 npt	1
235	117677	REDUCER; #6 JIC x #10 JIC	1

* Parts included in Check Valve Kit 249035.

† Parts included in Repair Kit 255148.

✓ Recommended spare parts. Keep on hand to avoid downtime.

241693 Stand Kit

Ref. No.	Part No.	Description	Qty.
401	236061	BRACKET, mounting	1
402	168422	CAP, square	6
403	217297	LEG, frame	2
404	178473	BRACE, frame	1
405	100679	SCREW, cap, hex hd; 1/2-13 x 3-1/2 in. (89 mm)	6
406	100321	NUT, hex; 1/2-13	6
407	100018	WASHER, lock; 1/2	6

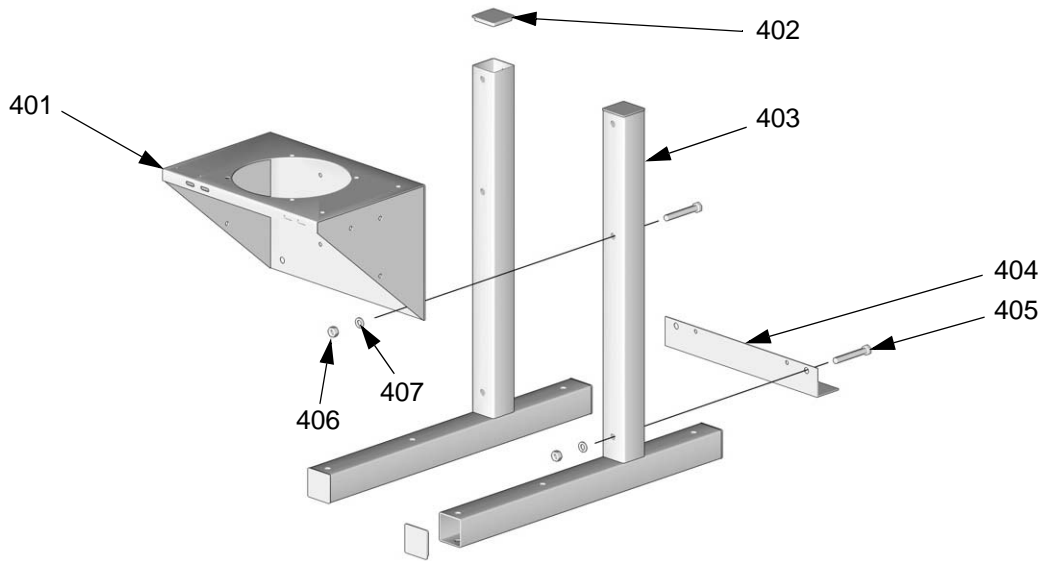

TI5629a

Technical Data

Maximum fluid working pressure	<i>Models 234932 and 234992: 4600 psi (31.7 MPa, 317 bar)</i> <i>All other models: 5000 psi (34.5 MPa, 345 bar)</i>
Maximum air input pressure	<i>Models 234931 and 234991: 70 psi (0.43 MPa, 4.3 bar)</i> <i>Models 234934 and 234994: 90 psi (0.62 MPa, 6.2 bar)</i> <i>Models 234932, 234933, 234992, and 234993: 100 psi (0.7 MPa, 7.0 bar)</i>
Pressure ratio	<i>Models 234931 and 234991: 68:1</i> <i>Models 234932 and 234992: 46:1</i> <i>Models 234933 and 234993: 50:1</i> <i>Models 234934 and 234994: 54:1</i>
Automatic overpressure relief	5300 psi (36.5 MPa, 365 bar)
Rupture disk protection	7100 psi (49 MPa, 490 bar)
Maximum recommended feed pressure	250 psi (1.7 MPa, 17 bar), or 25% of outlet pressure, whichever is lower
Volume ratio	<i>Models 234931 and 234991: 1:1</i> <i>Models 234932 and 234992: 2:1</i> <i>Models 234933 and 234993: 3:1</i> <i>Models 234934 and 234994: 4:1</i>
Fluid flow at 40 cpm	<i>Models 234931 and 234991: 1.8 gpm (6.8 lpm)</i> <i>Models 234932 and 234992: 2.7 gpm (10.0 lpm)</i> <i>Models 234933 and 234993: 2.4 gpm (9.0 lpm)</i> <i>Models 234934 and 234994: 2.3 gpm (8.7 lpm)</i>
Sound pressure, at 15 cycles/minute*	at 70 psi (0.48 MPa, 4.8 bar) input air pressure: 82.7 dB(A) at 100 psi (0.7 MPa, 7.0 bar) input air pressure: 88.2 dB(A)
Sound power, at 15 cycles/minute**	at 70 psi (0.48 MPa, 4.8 bar) input air pressure: 88.8 dB(A) at 100 psi (0.7 MPa, 7.0 bar) input air pressure: 98.0 dB(A)
Wetted parts	<i>Proportioner: carbon steel, stainless steel, brass, PTFE, LDPE, nylon</i> <i>Fluid manifold: carbon steel, stainless steel, brass, tungsten carbide, chemically resistant fluoroelastomer, PVDF</i> <i>Displacement pumps: see 307944</i>

All other brand names or marks are used for identification purposes and are trademarks of their respective owners.

* Sound pressure measured 1 meter from equipment.

** Sound power measured per ISO 9614-2.

Graco Standard Warranty

Graco warrants all equipment referenced in this document which is manufactured by Graco and bearing its name to be free from defects in material and workmanship on the date of sale to the original purchaser for use. With the exception of any special, extended, or limited warranty published by Graco, Graco will, for a period of twelve months from the date of sale, repair or replace any part of the equipment determined by Graco to be defective. This warranty applies only when the equipment is installed, operated and maintained in accordance with Graco's written recommendations.

This warranty does not cover, and Graco shall not be liable for general wear and tear, or any malfunction, damage or wear caused by faulty installation, misapplication, abrasion, corrosion, inadequate or improper maintenance, negligence, accident, tampering, or substitution of non-Graco component parts. Nor shall Graco be liable for malfunction, damage or wear caused by the incompatibility of Graco equipment with structures, accessories, equipment or materials not supplied by Graco, or the improper design, manufacture, installation, operation or maintenance of structures, accessories, equipment or materials not supplied by Graco.

This warranty is conditioned upon the prepaid return of the equipment claimed to be defective to an authorized Graco distributor for verification of the claimed defect. If the claimed defect is verified, Graco will repair or replace free of charge any defective parts. The equipment will be returned to the original purchaser transportation prepaid. If inspection of the equipment does not disclose any defect in material or workmanship, repairs will be made at a reasonable charge, which charges may include the costs of parts, labor, and transportation.

THIS WARRANTY IS EXCLUSIVE, AND IS IN LIEU OF ANY OTHER WARRANTIES, EXPRESS OR IMPLIED, INCLUDING BUT NOT LIMITED TO WARRANTY OF MERCHANTABILITY OR WARRANTY OF FITNESS FOR A PARTICULAR PURPOSE.

Graco's sole obligation and buyer's sole remedy for any breach of warranty shall be as set forth above. The buyer agrees that no other remedy (including, but not limited to, incidental or consequential damages for lost profits, lost sales, injury to person or property, or any other incidental or consequential loss) shall be available. Any action for breach of warranty must be brought within two (2) years of the date of sale.

GRACO MAKES NO WARRANTY, AND DISCLAIMS ALL IMPLIED WARRANTIES OF MERCHANTABILITY AND FITNESS FOR A PARTICULAR PURPOSE, IN CONNECTION WITH ACCESSORIES, EQUIPMENT, MATERIALS OR COMPONENTS SOLD BUT NOT MANUFACTURED BY GRACO. These items sold, but not manufactured by Graco (such as electric motors, switches, hose, etc.), are subject to the warranty, if any, of their manufacturer. Graco will provide purchaser with reasonable assistance in making any claim for breach of these warranties.

In no event will Graco be liable for indirect, incidental, special or consequential damages resulting from Graco supplying equipment hereunder, or the furnishing, performance, or use of any products or other goods sold hereto, whether due to a breach of contract, breach of warranty, the negligence of Graco, or otherwise.

FOR GRACO CANADA CUSTOMERS

The Parties acknowledge that they have required that the present document, as well as all documents, notices and legal proceedings entered into, given or instituted pursuant hereto or relating directly or indirectly hereto, be drawn up in English. Les parties reconnaissent avoir convenu que la rédaction du présente document sera en Anglais, ainsi que tous documents, avis et procédures judiciaires exécutés, donnés ou intentés, à la suite de ou en rapport, directement ou indirectement, avec les procédures concernées.

Graco Information

For the latest information about Graco products, visit www.graco.com.

TO PLACE AN ORDER, contact your Graco distributor or call to identify the nearest distributor.

Phone: 612-623-6921 **or Toll Free:** 1-800-328-0211 **Fax:** 612-378-3505

*All written and visual data contained in this document reflects the latest product information available at the time of publication.
Graco reserves the right to make changes at any time without notice.*

Original instructions. This manual contains English. MM 310796

Graco Headquarters: Minneapolis

International Offices: Belgium, China, Japan, Korea

GRACO INC. P.O. BOX 1441 MINNEAPOLIS, MN 55440-1441

Copyright 2004, Graco Inc. is registered to ISO 9001

www.graco.com

Revision G, July 2017