

NXT144 Air Valve Rebuild Kit

406657F

EN

***NXT144 kit is for motor series H and later.
For NXT107, NXT108, and NXT109 air valves.***

NXT is a registered trademark of Graco Inc.



Important Safety Instructions

Read all warnings and instructions in manual 311238. Save those instructions.

- ⚠️ 1 Apply lithium grease.
- ⚠️ 5 Thread in by hand, then torque to 130 in-lb (14.6 N•m) for all 11 screws.
- ⚠️ 7 Thread in by hand, then torque to 22 ft-lb (29.8 N•m).
- ⚠️ 8 Seal lips face down.
- ⚠️ 9 Seal lips face up.

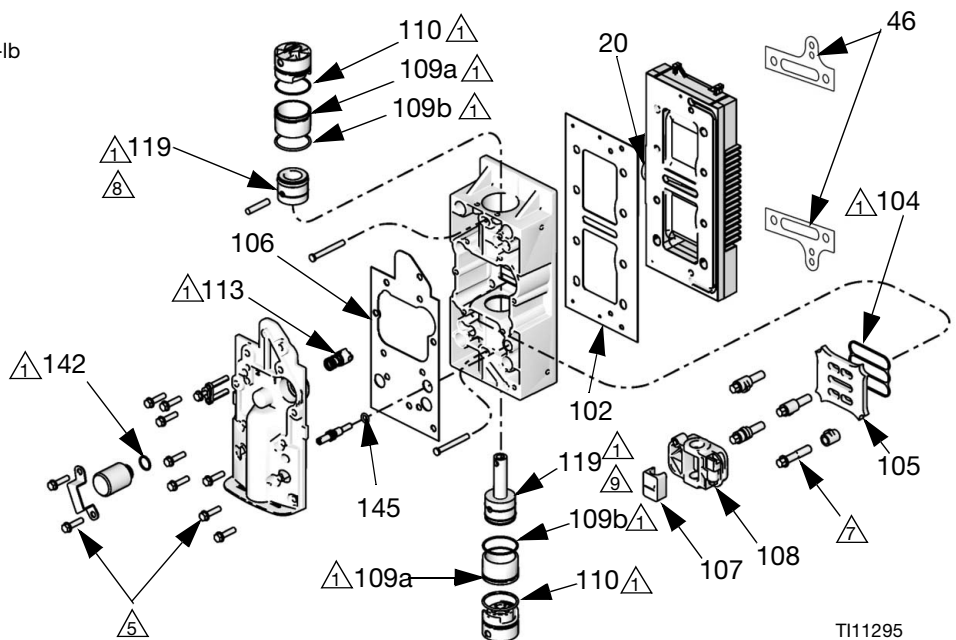

TI11295

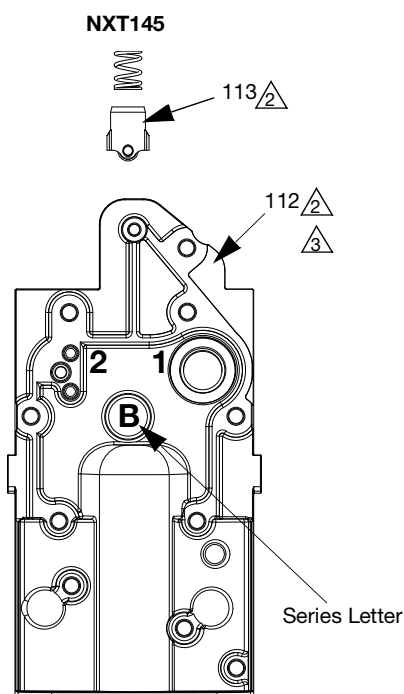

Ref.	Part	Description	Qty.
20	119990	O-RING, seal, exhaust	1
46	253476	GASKET, pair; air valve to end caps	1
102*	15H633	GASKET, exhaust housing	1
104	15F435	SEAL, valve, plate, rubber	1
105	15F438	PLATE, valve	1
106*	15H634	GASKET, cover	1
107	15G055	RAMP, detent	1
108	NXT138	CARRIAGE, air cup assy.	1
109	NXT140	KIT, valve sleeve, repair; includes 109a and 109b	2
109a		SLEEVE	
109b		O-RING	
110	108014	O-RING, plug, spool	2
113	NXT145	DETENT, int., spring	1
119	NXT142	VALVE, piston	1
142	104130	O-RING, hole, solenoid	1
145	159589	O-RING, stem, bleed	1

* Gasket color and material type will vary due to availability. Valve performance will not be affected.

NOTE: To use new detent NXT145 on pre-2009 motors, you must use valve cover 16A038. Order valve cover separately.

All written and visual data contained in this document reflects the latest product information available at the time of publication. Graco reserves the right to make changes at any time without notice.

For patent information, see www.graco.com/patents.

Original instructions. This manual contains English. MM 406657

Graco Headquarters: Minneapolis

International Offices: Belgium, China, Japan, Korea

GRACO INC. AND SUBSIDIARIES • P.O. BOX 1441 • MINNEAPOLIS MN 55440-1441 • USA

Copyright 2006, Graco Inc. All Graco manufacturing locations are registered to ISO 9001.

www.graco.com

Revision F, May 2022