

Instructions



Cleanshot™ Shut-Off Valve Repair Kit

309515B

EN

Part No. 244162

3600 psi (24.8 MPa, 248 bar) Maximum Working Pressure



Important Safety Instructions

Read all warnings and instructions provided
in manual 309642.

Repair

Pressure Relief Procedure



Follow the Pressure Relief Procedure whenever you see this symbol.



To reduce risk of serious injury, including fluid injection, follow this procedure when checking or servicing any part of spray system, when installing, cleaning or changing spray tips, and whenever you stop spraying.

1. Engage trigger safety.
2. Shut off pump or sprayer, disconnect power source, and open all air bleed valves.
3. Rotate spray valve knob counter-clockwise to FLUSH position.
4. Disengage trigger safety.
5. Hold metal part of gun firmly to side of a grounded metal pail. Trigger gun into paint pail to relieve pressure.
6. Engage trigger safety.
7. Open pump drain valve to relieve fluid pressure in pump, hose, and pole gun. Triggering in-line valve to relieve pressure may not be sufficient. Have a container ready to catch drainage.

If you suspect the spray tip or hose is completely clogged or that pressure has not been fully relieved after following steps above, VERY SLOWLY loosen hose end coupling to relieve pressure gradually. Then loosen it completely. Clear tip or hose obstruction.

Changing the Needle

NOTE: The components included in the Cleanshot Valve Repair Kit are packaged as two separate modules, individual pieces cannot be ordered separately.

Disassembly (upper module)

1. Without the spray tip installed, start sprayer.

2. Turn knob on Cleanshot Shut-Off Valve counter-clockwise to FLUSH position (see page 3).
3. Flush and prime spray system.
4. Follow Pressure Relief Procedure.
5. Install spray tip.
6. Turn knob on Cleanshot Shut-Off Valve to SPRAY (page 3).
7. Rotate Cleanshot Shut-Off Valve to any desired position within 180°. Do not use any tools.
8. Refer to your separate gun instruction manual for operating and tip cleaning instructions.

Flush and Spray



1. Follow Pressure Relief Procedure.
2. Removed tip guard (not shown).
3. Using a wrench, loosen seat (31a).
4. Remove seat (31a).
5. Unscrew module and removed from valve body.

Reassembly (upper module)

1. Insert seat (31a) module into valve body.
2. Tighten seat (31a) to 26-32 ft-lbs (35-43 N•m).

Disassembly (lower module)

1. Using a wrench, loosen nut (31k).
2. Removed nut (31k).
3. Removed lower module from valve body.

Reassembly (lower module)

1. Insert new lower module into valve body.
2. Tighten nut (31k) to 26-32 ft-lbs (35-43 N•m).

Parts

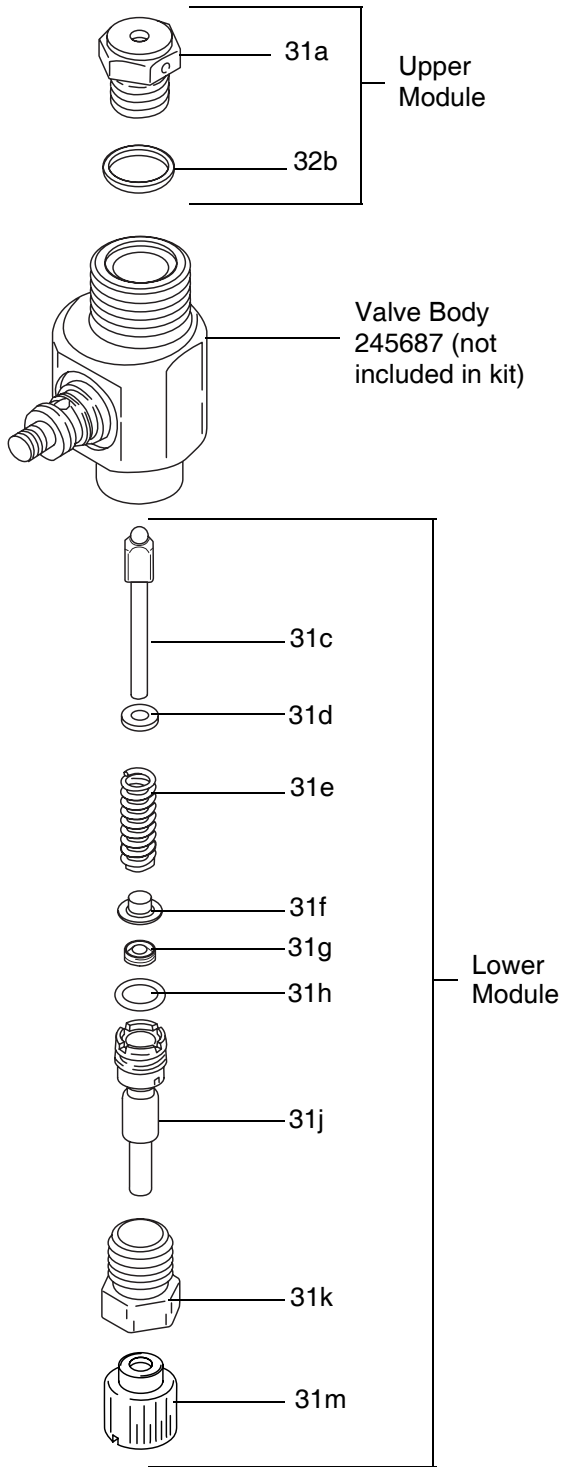

Ref No.	Part No.	Description	Qty
31	244162	KIT, Cleanshot™ repair, includes parts 31a-31h, 31j, 31k, 31m	1
31a		SEAT, valve	1
31b		GASKET	1
31c		RETAINER, ball	1
31d		DAMPENER, spring	1
31e		SPRING, compression	1
31f		GUIDE, spring	1
31g		SEAL, u-cup	1
31h		PACKING, o-ring	1
31j		RETAINER, u-cup	1
31k		CAP, nd, u-cup	1
31m		KNOB, valve	1

Graco Standard Warranty

Graco warrants all equipment referenced in this document which is manufactured by Graco and bearing its name to be free from defects in material and workmanship on the date of sale to the original purchaser for use. With the exception of any special, extended, or limited warranty published by Graco, Graco will, for a period of twelve months from the date of sale, repair or replace any part of the equipment determined by Graco to be defective. This warranty applies only when the equipment is installed, operated and maintained in accordance with Graco's written recommendations.

This warranty does not cover, and Graco shall not be liable for general wear and tear, or any malfunction, damage or wear caused by faulty installation, misapplication, abrasion, corrosion, inadequate or improper maintenance, negligence, accident, tampering, or substitution of non-Graco component parts. Nor shall Graco be liable for malfunction, damage or wear caused by the incompatibility of Graco equipment with structures, accessories, equipment or materials not supplied by Graco, or the improper design, manufacture, installation, operation or maintenance of structures, accessories, equipment or materials not supplied by Graco.

This warranty is conditioned upon the prepaid return of the equipment claimed to be defective to an authorized Graco distributor for verification of the claimed defect. If the claimed defect is verified, Graco will repair or replace free of charge any defective parts. The equipment will be returned to the original purchaser transportation prepaid. If inspection of the equipment does not disclose any defect in material or workmanship, repairs will be made at a reasonable charge, which charges may include the costs of parts, labor, and transportation.

THIS WARRANTY IS EXCLUSIVE, AND IS IN LIEU OF ANY OTHER WARRANTIES, EXPRESS OR IMPLIED, INCLUDING BUT NOT LIMITED TO WARRANTY OF MERCHANTABILITY OR WARRANTY OF FITNESS FOR A PARTICULAR PURPOSE.

Graco's sole obligation and buyer's sole remedy for any breach of warranty shall be as set forth above. The buyer agrees that no other remedy (including, but not limited to, incidental or consequential damages for lost profits, lost sales, injury to person or property, or any other incidental or consequential loss) shall be available. Any action for breach of warranty must be brought within two (2) years of the date of sale.

GRACO MAKES NO WARRANTY, AND DISCLAIMS ALL IMPLIED WARRANTIES OF MERCHANTABILITY AND FITNESS FOR A PARTICULAR PURPOSE, IN CONNECTION WITH ACCESSORIES, EQUIPMENT, MATERIALS OR COMPONENTS SOLD BUT NOT MANUFACTURED BY GRACO. These items sold, but not manufactured by Graco (such as electric motors, switches, hose, etc.), are subject to the warranty, if any, of their manufacturer. Graco will provide purchaser with reasonable assistance in making any claim for breach of these warranties.

In no event will Graco be liable for indirect, incidental, special or consequential damages resulting from Graco supplying equipment hereunder, or the furnishing, performance, or use of any products or other goods sold hereto, whether due to a breach of contract, breach of warranty, the negligence of Graco, or otherwise.

FOR GRACO CANADA CUSTOMERS

The Parties acknowledge that they have required that the present document, as well as all documents, notices and legal proceedings entered into, given or instituted pursuant hereto or relating directly or indirectly hereto, be drawn up in English. Les parties reconnaissent avoir convenu que la rédaction du présente document sera en Anglais, ainsi que tous documents, avis et procédures judiciaires exécutés, donnés ou intentés, à la suite de ou en rapport, directement ou indirectement, avec les procédures concernées.

Graco Information

For the latest information about Graco products, visit www.graco.com.

For patent information, see www.graco.com/patents.

TO PLACE AN ORDER, contact your Graco distributor or call 1-800-690-2894 to identify the nearest distributor.

*All written and visual data contained in this document reflects the latest product information available at the time of publication.
Graco reserves the right to make changes at any time without notice.*

For patent information, see www.graco.com/patents

Original instructions. This manual contains English. MM 309515

Graco Headquarters: Minneapolis

International Offices: Belgium, China, Japan, Korea

GRACO INC. AND SUBSIDIARIES • P.O. BOX 1441 • MINNEAPOLIS MN 55440-1441 • USA

Copyright 2001, Graco Inc. All Graco manufacturing locations are registered to ISO 9001.

www.graco.com

Revision B, December 2013