

# Instructions–Parts List

## APS-100 Primer Spray Module

310109G

*Used to circulate, dispense, and apply AFS primers. Not for use in Explosive Atmosphere locations.*

### Module 970246

*100 psi (0.7 MPa, 7 bar) Maximum Fluid Working Pressure*

*100 psi (0.7 MPa, 7 bar) Maximum Air Input Pressure*

Each module is a primer circulating and dispensing module which includes a 5-gallon pail cover, Husky™ 515 diaphragm pump, back pressure regulator, and air dryer.



#### **Important Safety Instructions**

Read all warnings and instructions in this manual.  
Save these instructions.

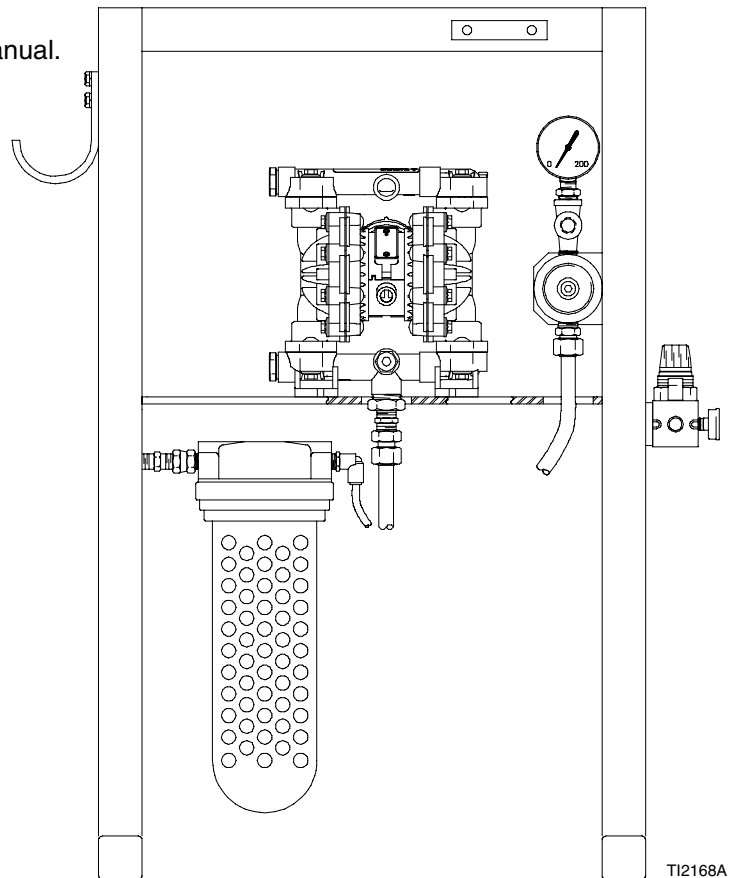

TI2168A

# Table of Contents

Symbols .....	2	Operation .....	7
Warnings .....	2	Module Operation .....	7
Installation .....	4	Maintenance .....	8
Grounding .....	4	Parts .....	10
Pressure Relief Procedure .....	4	Technical Data .....	13
Module Description .....	5	Graco Standard Warranty .....	14
Module Installation .....	5	Graco Information .....	14

## Symbols

### Warning Symbol



This symbol alerts you to the possibility of serious injury or death if you do not follow the instructions.

### Caution Symbol



This symbol alerts you to the possibility of damage to or destruction of equipment if you do not follow the instructions.

## ⚠ WARNING

	<p><b>PRESSURIZED FLUID HAZARD</b></p> <p>Spray from the gun, hose leaks, or ruptured components can splash fluid in the eyes or on the skin and cause serious injury.</p> <ul style="list-style-type: none"> <li>● Do not stop or deflect fluid leaks with your hand, glove, or rag.</li> <li>● Follow the <b>Pressure Relief Procedure</b> on page 4 before cleaning, checking, or servicing the equipment.</li> <li>● Tighten all fluid connections before each use.</li> <li>● Check the hoses, tubes, and couplings daily. Replace parts immediately if worn, damaged, or loose. Permanently coupled hoses cannot be repaired.</li> </ul>
---	--

	<p><b>FIRE AND EXPLOSION HAZARD</b></p> <p>Improper grounding, poor air ventilation, open flames, or sparks can cause a hazardous condition and result in fire or explosion and serious injury.</p> <ul style="list-style-type: none"> <li>● Ground the equipment, the object being sprayed, and all other electrically conductive objects in the spray area. See <b>Grounding</b> on page 4.</li> <li>● If there is any static sparking while using the equipment, <b>stop spraying immediately</b>. Identify and correct the problem.</li> <li>● Provide fresh air ventilation to avoid the buildup of flammable vapors from the solvent or the fluid being sprayed.</li> <li>● Do not smoke in the spray area.</li> <li>● Extinguish all open flames or pilot lights in the spray area.</li> <li>● Do not turn on or off any light switch in the spray area.</li> <li>● Electrically disconnect all equipment in the spray area.</li> <li>● Keep the spray area free of debris, including solvent, rags, and gasoline.</li> <li>● Do not operate a gasoline engine in the spray area.</li> </ul>
---	---

# WARNING



INSTRUCTIONS



## EQUIPMENT MISUSE HAZARD

Equipment misuse can cause the equipment to rupture, malfunction, or start unexpectedly and result in a serious injury.

- This equipment is for professional use only.
- Read all the instruction manuals, tags, and labels before operating the equipment.
- Use the equipment only for its intended purpose. If you are uncertain about usage, call your Graco distributor.
- Do not alter or modify this equipment. Use only genuine Graco parts and accessories.
- Check the equipment daily. Repair or replace worn or damaged parts immediately.
- Do not exceed the maximum working pressure of the lowest rated system component. This package has a **100 psi (0.7 MPa, 7 bar) maximum working pressure**.
- Use fluids that are compatible with the equipment wetted parts. See the **Technical Data** section of all the equipment manuals. Read the fluid manufacturer's warnings.
- Route the hoses away from traffic areas, sharp edges, moving parts, and hot surfaces. Do not expose Graco hoses to temperatures above 180°F (82°C) or below -40°F (-40°C).
- Do not use the hoses to pull equipment.
- Wear hearing protection when operating this equipment.
- Comply with all applicable local, state, and national fire, electrical, and other safety regulations.



## TOXIC FLUID HAZARD

Hazardous fluids or toxic fumes can cause a serious injury or death if splashed in the eyes or on the skin, swallowed, or inhaled.

- Know the specific hazards of the fluid you are using. Read the fluid manufacturer's warnings.
- Store hazardous fluid in an approved container. Dispose of the hazardous fluid according to all local, state, and national guidelines.
- Wear appropriate protective clothing, gloves, eyewear, and respirator.
- If the pump diaphragm fails, hazardous fluid may be exhausted along with the air.

# Installation

## Grounding

### WARNING

To reduce the risk of static sparking, ground the pump, object being sprayed, and all other spray equipment used or located in spray area. Check your local electrical code for detailed grounding instructions for your area and type of equipment. Ground all of this equipment. Also read **Fire and Explosion Hazard** on page 2.

- *Pump:* See manual 308981.
- *Hoses:* Use only electrically conductive hose.
- *Air compressor:* Follow the manufacturer's recommendations.
- *Spray gun:* Grounding is obtained through connection to a properly grounded fluid hose and pump.
- *Fluid supply container:* Follow the local code.
- *Object being sprayed:* Follow the local code.
- *All solvent pails used when flushing:* Follow the local code. Use only metal pails, which are conductive. Do not place the pail on a non-conductive surface, such as paper or cardboard, which interrupts the grounding continuity.

*To maintain grounding continuity when flushing or relieving pressure, always hold a metal part of the spray gun firmly to the side of a grounded metal pail, then trigger the spray gun.*

## Pressure Relief Procedure

### WARNING

The system remains pressurized until pressure is manually relieved. To reduce the risk of serious injury from pressurized fluid, splashing in the eyes or on the skin, or injury from moving parts, follow this procedure whenever you

- Stop spraying
  - Are instructed to relieve pressure
  - Check or service any system equipment
  - Install, clean, or change spray nozzles
1. Engage the gun safety latch.
  2. Shut off air to the pump.
  3. Close the bleed-type master air valve (required in your system).
  4. Disengage the safety latch.
  5. Hold a metal part of the spray gun firmly to the side of a grounded metal pail, and trigger the spray gun to relieve pressure.
  6. Engage the gun safety latch.
  7. Open the drain valve and/or the pump bleeder valve (required in your system), having a container ready to catch the drainage.
  8. Leave the drain valve open until you are ready to spray/dispense again.

If you suspect that the gun tip/nozzle or hose is completely clogged, or that pressure has not been fully relieved after following the steps above, *very slowly* loosen the retaining nut or hose end coupling and relieve pressure gradually, then loosen completely. Now clear the tip/nozzle or hose.

# Installation

## Module Description

Module 970246 pumps and circulates primer to a manual dispense gun. The module features a diaphragm pump which circulates a low-viscosity primer from a 5-gal. pail through a 25 ft supply/return hose to a gun-mounted circulating fitting, and returns primer through a back pressure regulator to the original supply pail. The module supplies fluid to the manual gun to keep an application brush moist with primer material.

A desiccant dryer is also supplied to keep moisture away from the material to prevent curing within the module. The air dryer kit provides dehumidified air to the supply pail. As the material level in the pail lowers, dry air is drawn in through the hose from the dryer.

For procedures listed in this section, refer to the **Parts** drawing on page 10, as well as the following component instruction manuals:

Description	Manual No.
Model 600N Air Spray Gun	308980
Back Pressure Valve	306640
Husky 515 Double Diaphragm Pump	308981

## Module Installation



**WARNING**



**FIRE, EXPLOSION, AND ELECTROSTATIC SHOCK HAZARD**

Fluid dispensing can cause a static charge to build, which can spark and cause electrical shock or explosions. Always ground the dispensing equipment before operating. Refer to the **FIRE AND EXPLOSION HAZARD** on page 2.

**WARNING**



**PRESSURIZED FLUID HAZARD**

To reduce the risk of serious injury, such as splashing fluid in the eyes or on the skin, *always* wear eye protection and protective clothing when installing, operating, or servicing this dispensing module.

## Locate and Secure Diaphragm Pump Module

1. Locate the module on a level, even surface.
2. Locate and secure the module in an area safe for operation.
3. When installing the air dryer:
  - a. Remove the dryer bowl by unscrewing the ring securing it. Replace the bowl and ring. Tighten the ring hand-tight.
  - b. Remove the filter from the top of the bowl and fill the bowl with the desiccant crystals provided with the kit. Reinstall the filter and bowl.
  - c. Install the air dryer fittings in the 3/4 in. vent port of the drum of fluid. Close the shutoff valve and connect the dry air hoses. Use only the special pin fittings and coupler to connect the dry air hoses to the drum fittings.
4. Verify that the position of the module allows the material hoses to reach the dispensing guns when attached to the supply module.
5. Install the siphon kit in the material pail:
  - a. Screw and tighten the bung adapter nut into the pail cover firmly to complete the air-tight seal.
  - b. Insert the pump suction tube through the bung adapter into the drum, and secure in position.
  - c. Install the air regulator near the diaphragm pump to control pump speed.
6. Connect the hoses from pump outlets to the dispense gun inlet.

## Connect Material Hoses

**WARNING**

To reduce the risk of injury or equipment damage, make sure all material hose connections are secure.

Locating and securing the material hoses:

1. If the material hose to the gun is to be suspended by a hanger or tool balancer, route the hose through the suspension device before securing each end of the material hose.
2. Lay out and connect all material hoses as shown in the **Parts** drawing on page 10 using PTFE tape or other appropriate means to prevent leaks.
3. Tighten the material hoses securely to prevent material leakage.

# Installation

## Connect Air Supply

### **⚠ WARNING**

To reduce the risk of injury or equipment damage, do not pressurize the module until you have verified the module is ready and it is safe to do so.

Connect a 1/4 in. npt air supply to the air inlet connection of the filter/regulator/lubricator assembly on the diaphragm pump.

## Load Material

### **⚠ WARNING**

To reduce the risk of injury or equipment damage, make sure all material hose connections are secure.

### **⚠ WARNING**



#### **COMPONENT RUPTURE HAZARD**

Never exceed the maximum air or fluid working pressure rating of the lowest rated component in the system. Over-pressurization can cause component rupture and serious bodily injury.

Follow this procedure to fill the pump, load and circulate material in the lines, and adjust material flow:

1. Shut off air supply to the diaphragm pump.
2. Verify the siphon tube assembly is securely mounted on the pail lid.
3. Verify the return line is securely mounted to the pail lid.
4. Verify the lid is securely mounted on the pail, and the air line from the desiccant dryer is attached to the pail lid.
5. Adjust the back pressure regulator for zero or minimum back pressure.
6. Adjust the needle valve on the dispense gun so that it is open about 1–2 turns.

7. Adjust the pump regulator to about 15–20 psi (0.1–0.14 MPa, 1–1.4 bar). This will start the pump.
8. Allow the material to flow into the lines and circulate. The pump will run continuously to circulate material through the hoses even when the gun is not dispensing.

## Adjust the Flow Rate

1. Operating the spray gun, dispense into a waste container, or apply material to a suitable test object, to test the flow. The material should saturate the brush for even application without dripping.
2. If more flow is needed to saturate the brush, open the needle valve (A) on the dispense valve or gun up to an additional turn to increase the flow (Fig. 1). If more pressure is required, adjust the back pressure regulator. If necessary to maintain pressure, increase the air regulator setting to the supply pump.

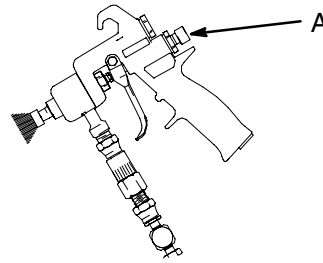

Fig. 1

TI2171A

3. If less flow is needed to prevent dripping, adjust the needle valve up to a half turn toward the closed position to decrease the flow. If less pressure is required, adjust the back pressure regulator. If necessary to decrease pressure further, decrease the air regulator setting to the supply pump.

## Record Operating Settings

With the system correctly adjusted and operating, record all operating settings and retain a copy of the settings with the system. This will permit the system to be quickly returned to production operation after drum changing or servicing.

**NOTE:** Label gauges and controls with the production settings for easy operator reference.

# Operation

## Module Operation

### Module Startup

1. Visually inspect the entire module for any leaks, damage, or signs of wear. Repair all leaks and replace any worn or damaged parts before starting the module.
2. Check the dispense gun to make sure the tip is clear and the gun is ready for operation.
3. Check hose connections for tightness to prevent material leaks.
4. Turn on the main air lockout valve to the module.
5. Verify that all equipment settings are correct for operation.
6. Test the spray gun into a waste container or onto a scrap part to verify operation.
7. Verify that the flow rate is correct and adjust if necessary.

### Changing an Empty Pail

**⚠ WARNING**

 **PRESSURIZED FLUID HAZARD**

To reduce the risk of serious injury, such as splashing fluid in the eyes or on the skin, *always* wear eye protection and protective clothing when installing, operating, or servicing this dispensing module.

When a pail of material is empty, follow this procedure to change to a new pail of material:

1. Shut off the air supply to the diaphragm pump.
2. Open the dispense gun over a suitable waste container to relieve all module pressure. See the **Pressure Relief Procedure** on page 4. Close the dispense gun.
3. Operate the lid release, and remove the lid from the empty pail.
4. Position a new pail of material in place of the empty pail.
5. Securely mount the lid on the new pail.
6. Turn on the air supply to the diaphragm pump.
7. Proceed with operation. See **Adjust the Flow Rate** on page 6, if necessary to adjust the material flow.

### Module Shutdown

To shut down the module:

1. Shut off the air supply to the pump.
2. Open the back pressure regulator all the way.
3. Follow the **Pressure Relief Procedure** on page 4.
4. Clean the dispense gun and prepare it for a period of disuse.

### Air Dryer Maintenance

When the silica gel in the air dryer changes color, due to moisture absorption, replace the silica gel. Use Graco Part No. 106498 Silica Gel to replenish the air dryer.

Refer to the instruction manuals for the pump, gun, and back pressure regulator for maintenance information on those components. See page 5 for a list of manual numbers.

# Maintenance

## Air Filter and Lubricator

**NOTE:** The frequency of maintenance and chance of breakdown of air-driven components in the system can be minimized by proper maintenance and use of these components, which are responsible for air supply quality.

1. Drain filter and water trap units daily.
2. Check lubricator oil weekly or as required.
3. Adjust lubricators to one drop of oil every minute. This is approximately 1/2 turn open.
4. In the absence of specific directions for this system or component, use only 10w non-detergent oil in the lubricator assembly.



# Parts

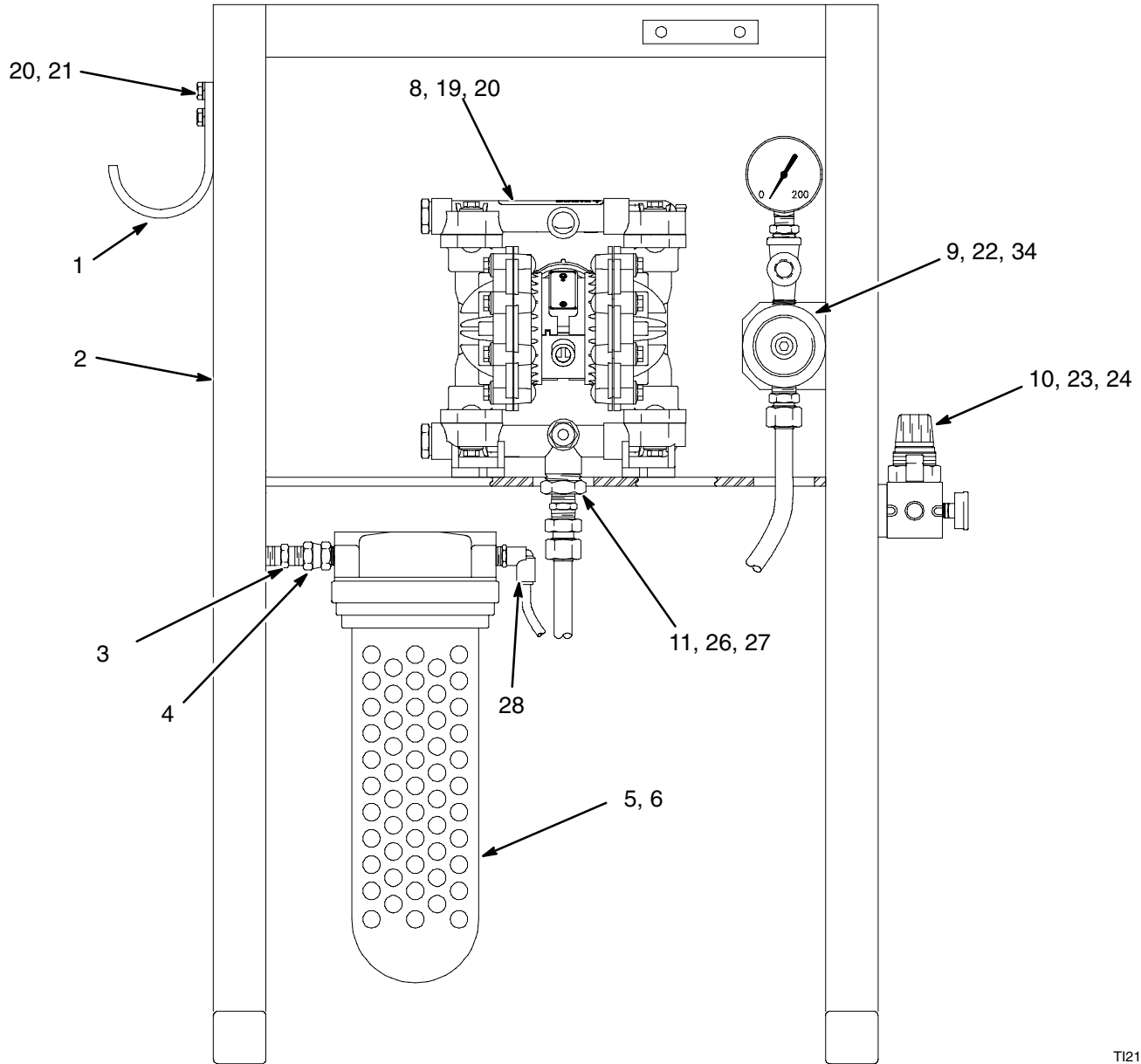

TI2170A

# Parts

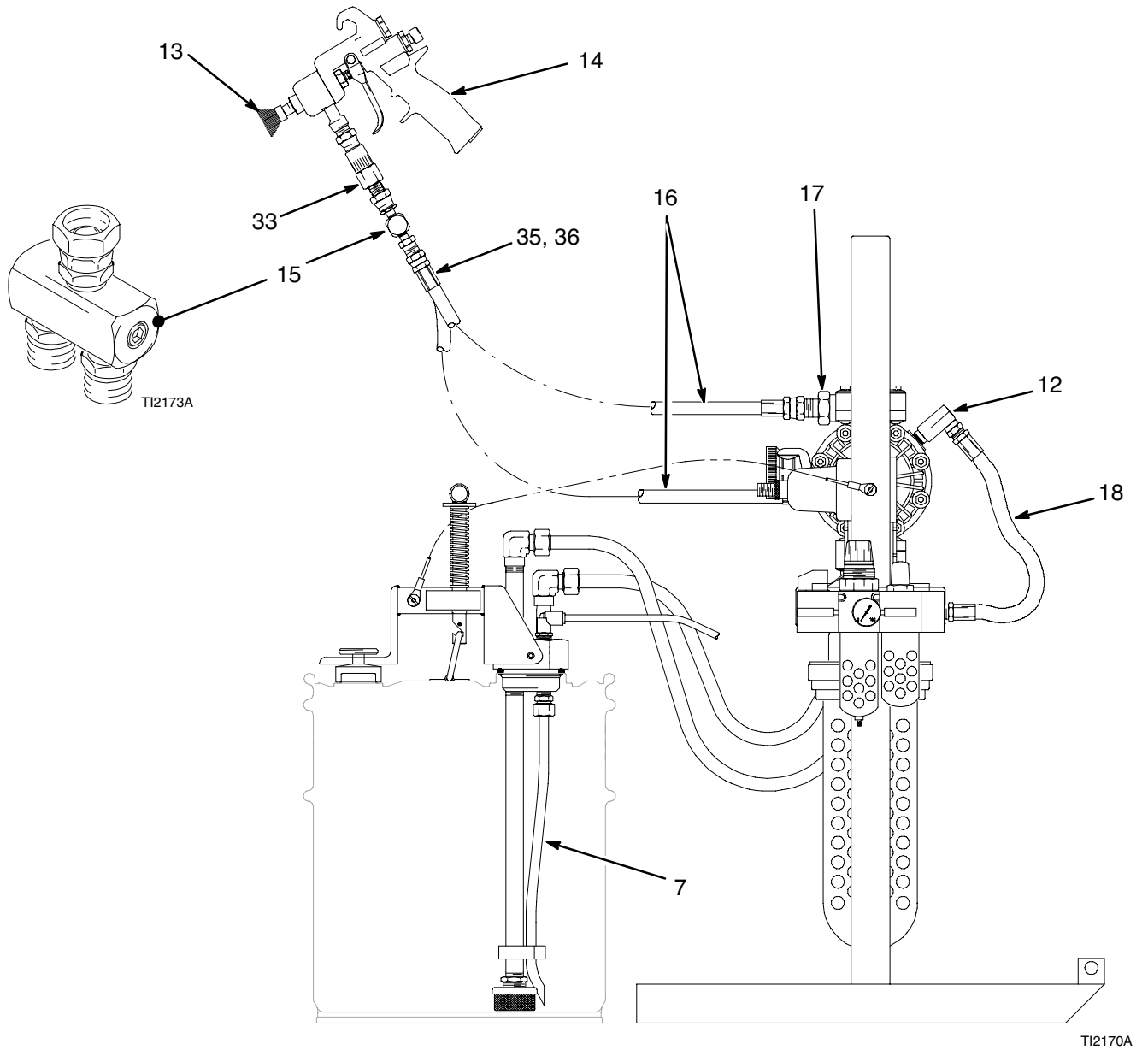

# Parts

## Module 970246

Ref. No.	Part No.	Description	Qty.	Ref. No.	Part No.	Description	Qty.
1	617059	BRACKET	1	17	159239	NIPPLE; 1/2 X 3/8 npt	1
2	617058	FRAME	1	18	518893	HOSE; 1/4 npt(m)	1
3	156971	NIPPLE	1	19	112166	SCREW, cap, socket head	5
4	156823	UNION, swivel	1	20	C19209	WASHER, lock	4
5	510896	FILTER, dessicant dryer	1	21	516149	BOLT, hex head; stainless steel	2
6	106498	GEL; silica	1	22	C20003	SCREW, cap, socket head	2
7	918235	TUBE, siphon	1	23	100016	WASHER, lock	3
8	241564	PUMP, Husky 515 diaphragm	1	24	C20007	SCREW, cap, socket head	2
9	916133	REGULATOR, back pressure	1	26	C20483	NIPPLE, hex; 3/8 npt	1
10	518891	FILTER/REGULATOR/ LUBRICATOR ASSY.	1	27	C38378	FITTING, female; 3/8 npt(m) x 1/2 OD	1
11	C19683	BUSHING, reducing	1	28	C19391	ELBOW; 1/4 npt x 1/4 OD	1
12	155541	UNION, swivel; 90°	1	33	239663	SWIVEL, straight	1
13	521041	BRUSH. nozzle	1	34	100020	WASHER, lock	2
14	241778	GUN ASSY., primer	1	35	552071	SLEEVE, protective	24
15	208433	MANIFOLD, circulating	1	36		TAPE, electrical (as required)	
16	C12488	HOSE; PTFE; 1/4 x 3/8 npsm	2				

# Technical Data

Category	Data
Maximum fluid working pressure	100 psi (0.7 MPa, 7 bar)
Maximum air input pressure	100 psi (0.7 MPa, 7 bar)
Fittings	<i>Model 518893:</i> 1/4 in. npt(m) brass <i>Model C12488:</i> 3/8 in. npsm swivel with stainless steel spring guard to 1/4 in. npsm swivel with stainless steel spring guard
Length	<i>Model 518893:</i> 18 ft (5.5 m) <i>Model C12488:</i> 25 ft (7.6 m)
Inside diameter	1/4 in.
Outside diameter	<i>Model 518893:</i> 1/2 in. <i>Model C12488:</i> 11/32 in.
Material	<i>Model 518893:</i> Nitrile core, neoprene cover with one textile braid <i>Model C12488:</i> PTFE

# Graco Standard Warranty

Graco warrants all equipment manufactured by Graco and bearing its name to be free from defects in material and workmanship on the date of sale to the original purchaser for use. With the exception of any special, extended, or limited warranty published by Graco, Graco will, for a period of twelve months from the date of sale, repair or replace any part of the equipment determined by Graco to be defective. This warranty applies only when the equipment is installed, operated and maintained in accordance with Graco's written recommendations.

This warranty does not cover, and Graco shall not be liable for general wear and tear, or any malfunction, damage or wear caused by faulty installation, misapplication, abrasion, corrosion, inadequate or improper maintenance, negligence, accident, tampering, or substitution of non-Graco component parts. Nor shall Graco be liable for malfunction, damage or wear caused by the incompatibility of Graco equipment with structures, accessories, equipment or materials not supplied by Graco, or the improper design, manufacture, installation, operation or maintenance of structures, accessories, equipment or materials not supplied by Graco.

This warranty is conditioned upon the prepaid return of the equipment claimed to be defective to an authorized Graco distributor for verification of the claimed defect. If the claimed defect is verified, Graco will repair or replace free of charge any defective parts. The equipment will be returned to the original purchaser transportation prepaid. If inspection of the equipment does not disclose any defect in material or workmanship, repairs will be made at a reasonable charge, which charges may include the costs of parts, labor, and transportation.

**THIS WARRANTY IS EXCLUSIVE, AND IS IN LIEU OF ANY OTHER WARRANTIES, EXPRESS OR IMPLIED, INCLUDING BUT NOT LIMITED TO WARRANTY OF MERCHANTABILITY OR WARRANTY OF FITNESS FOR A PARTICULAR PURPOSE.**

Graco's sole obligation and buyer's sole remedy for any breach of warranty shall be as set forth above. The buyer agrees that no other remedy (including, but not limited to, incidental or consequential damages for lost profits, lost sales, injury to person or property, or any other incidental or consequential loss) shall be available. Any action for breach of warranty must be brought within two (2) years of the date of sale.

Graco makes no warranty, and disclaims all implied warranties of merchantability and fitness for a particular purpose in connection with accessories, equipment, materials or components sold but not manufactured by Graco. These items sold, but not manufactured by Graco (such as electric motors, switches, hose, etc.), are subject to the warranty, if any, of their manufacturer. Graco will provide purchaser with reasonable assistance in making any claim for breach of these warranties.

In no event will Graco be liable for indirect, incidental, special or consequential damages resulting from Graco supplying equipment hereunder, or the furnishing, performance, or use of any products or other goods sold hereto, whether due to a breach of contract, breach of warranty, the negligence of Graco, or otherwise.

## **FOR GRACO CANADA CUSTOMERS**

The parties acknowledge that they have required that the present document, as well as all documents, notices and legal proceedings entered into, given or instituted pursuant hereto or relating directly or indirectly hereto, be drawn up in English. Les parties reconnaissent avoir convenu que la rédaction du présente document sera en Anglais, ainsi que tous documents, avis et procédures judiciaires exécutés, donnés ou intentés à la suite de ou en rapport, directement ou indirectement, avec les procédures concernées.

# Graco Information

**TO PLACE AN ORDER**, contact your Graco distributor, or call one of the following numbers to identify the distributor closest to you:

**1-800-328-0211 Toll Free**

**612-623-6921**

**612-378-3505 Fax**

*All written and visual data contained in this document reflect the latest product information available at the time of publication.*

*Graco reserves the right to make changes at any time without notice.*

This manual contains English. MM 310109

**Graco Headquarters:** Minneapolis

**International Offices:** Belgium, China, Japan, Korea

**GRACO INC. P.O. BOX 1441 MINNEAPOLIS, MN 55440-1441**

Copyright 2002, Graco Inc. is registered to I.S. EN ISO 9001

**[www.graco.com](http://www.graco.com)**

Revised 8/2008