

3 IN. AND 6.5 IN. RAM

## Low Level Shutoff Kit

310294K

EN

*250 psi (1.7 MPa, 17.2 bar) Maximum Air Inlet Pressure*

### Part No. 918478, Series A

Low Level Shutoff Kit

### Part No. 918396, Series A

Low Level Shutoff Kit

### Part No. 241652, Series A

Low Level Shutoff Kit With Audible Alarm



#### Important Safety Instructions

Read all warnings and instructions in this manual.  
Save these instructions.

## Table of Contents

Warnings .....	2
Installation .....	4
Parts .....	5
Graco Standard Warranty .....	8
Graco Information .....	8

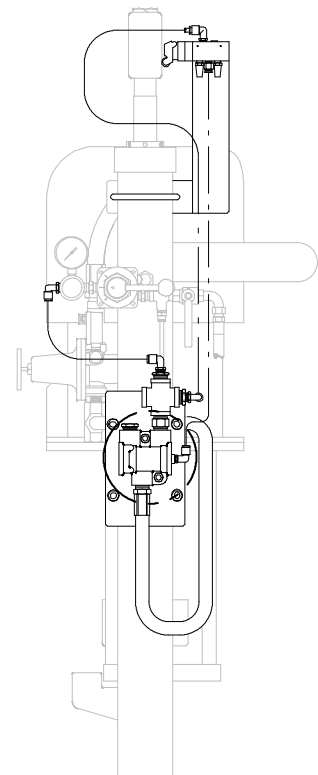

# Symbols

## Warning Symbol



This symbol alerts you to the possibility of serious injury or death if you do not follow the instructions.

## Caution Symbol



This symbol alerts you to the possibility of damage to or destruction of equipment if you do not follow the instructions.

## WARNINGS



INSTRUCTIONS

### EQUIPMENT MISUSE HAZARD

Equipment misuse can cause the equipment to rupture or malfunction and result in serious injury.

- This equipment is for professional use only.
- Read all instruction manuals, tags, and labels before operating the equipment.
- Use the equipment only for its intended purpose. If you are not sure, call your Graco distributor.
- Do not alter or modify this equipment. Use only genuine Graco parts and accessories.
- Check equipment daily. Repair or replace worn or damaged parts immediately.
- Do not exceed the maximum working pressure stated on the equipment or in the **Technical Data** for your equipment. Do not exceed the maximum working pressure of the lowest rated component in your system.
- Use fluids and solvents which are compatible with the equipment wetted parts. Refer to **Technical Data** section of all equipment manuals. Read the fluid and solvent manufacturer's warnings.
- Wear hearing protection when operating this equipment.
- Comply with all applicable local, state, and national fire, electrical, and safety regulations.

# WARNINGS



## MOVING PARTS HAZARD

Moving parts, such as the ram follower plate/pump inlet can pinch fingers.

- Do not operate the equipment with the guard removed.
- Keep clear of all moving parts when starting or operating the equipment.
- Keep hands and fingers away from the priming piston during operation and whenever the pump is charged with air.
- Keep clear of the follower plate, pump fluid inlet, and lip of the fluid container when raising or lowering the ram.
- Before checking or servicing the ram or pump, follow the **Pressure Relief Procedure** in the ram or pump manual.



## TOXIC FLUID HAZARD

Hazardous fluid or toxic fumes can cause serious injury or death if splashed in the eyes or on the skin, inhaled, or swallowed.

- Know the specific hazards of the fluid you are using.
- Store hazardous fluid in an approved container. Dispose of hazardous fluid according to all local, state and national guidelines.
- Always wear protective eyewear, gloves, clothing and respirator as recommended by the fluid and solvent manufacturer.
- Avoid exposure to heated material fumes.
- Provide adequate ventilation.

# Installation

## Prepare the Site

**NOTE:** Always use Genuine Graco Parts and Accessories, available from your Graco distributor. If you supply your own accessories, be sure they are adequately sized and pressure rated for your system.

Bring a compressed air supply line from the air compressor to the pump location. Be sure all air hoses are properly sized and pressure-rated for your system. Use only electrically conductive hoses. The air hose should have a 3/4 npsm(m) thread.

Before installing any air line components, blow out the air lines to remove scale and other debris. Use pipe compound or tape sparingly and only on male threads.

Install a bleed-type shutoff valve in the air line upstream from all other air line components, to isolate them for servicing.

## Application

The low level shutoff kit is designed to shut the ram off when the drum becomes empty.

## Typical Low Level Shutoff Kit Installation

### **⚠ WARNING**

Never leave fingers between the ram plate and the drum when the ram plate is being operated.

### **⚠ WARNING**

Never enter the operating area of the ram, when the ram is in the top position. When the air pressure is lost or in the case of leaks in the air pressure system, the ram plate may drop.

The typical installation, shown on the cover of this manual, is only a guide. See the system manual for your application or contact your Graco distributor for assistance in designing a system to meet your needs.

See your ram manual if installing a new ram or relocating an existing ram.

## Low Level Shutoff Kit Setup

Install the low level shutoff as shown in the parts drawing for your model (see pages 5-7). See also Fig. 1.

**NOTE:** During system operation, as the ram approaches the drum bottom, the top of the ram contacts the limit valve switch. The switch shuts off air to the air motor. This allows changing out of material drums.

**NOTE:** The position of the limit valve on the ram determines when the ram air motor is turned off. During operation this position can be adjusted as desired.

Adjust limit valve to trip with the ram plate 1" from base plate.

**NOTE:** Do not remove factory installed plugs from pilot ports.

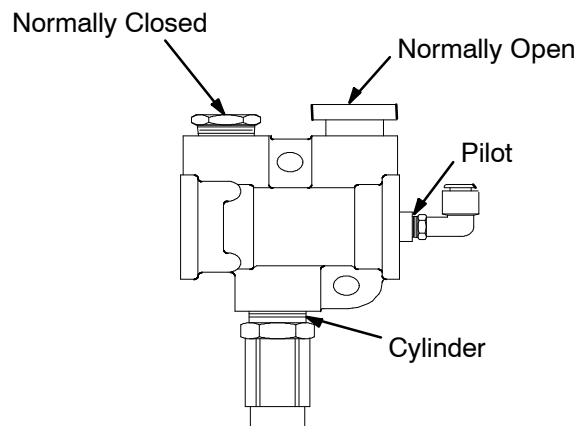
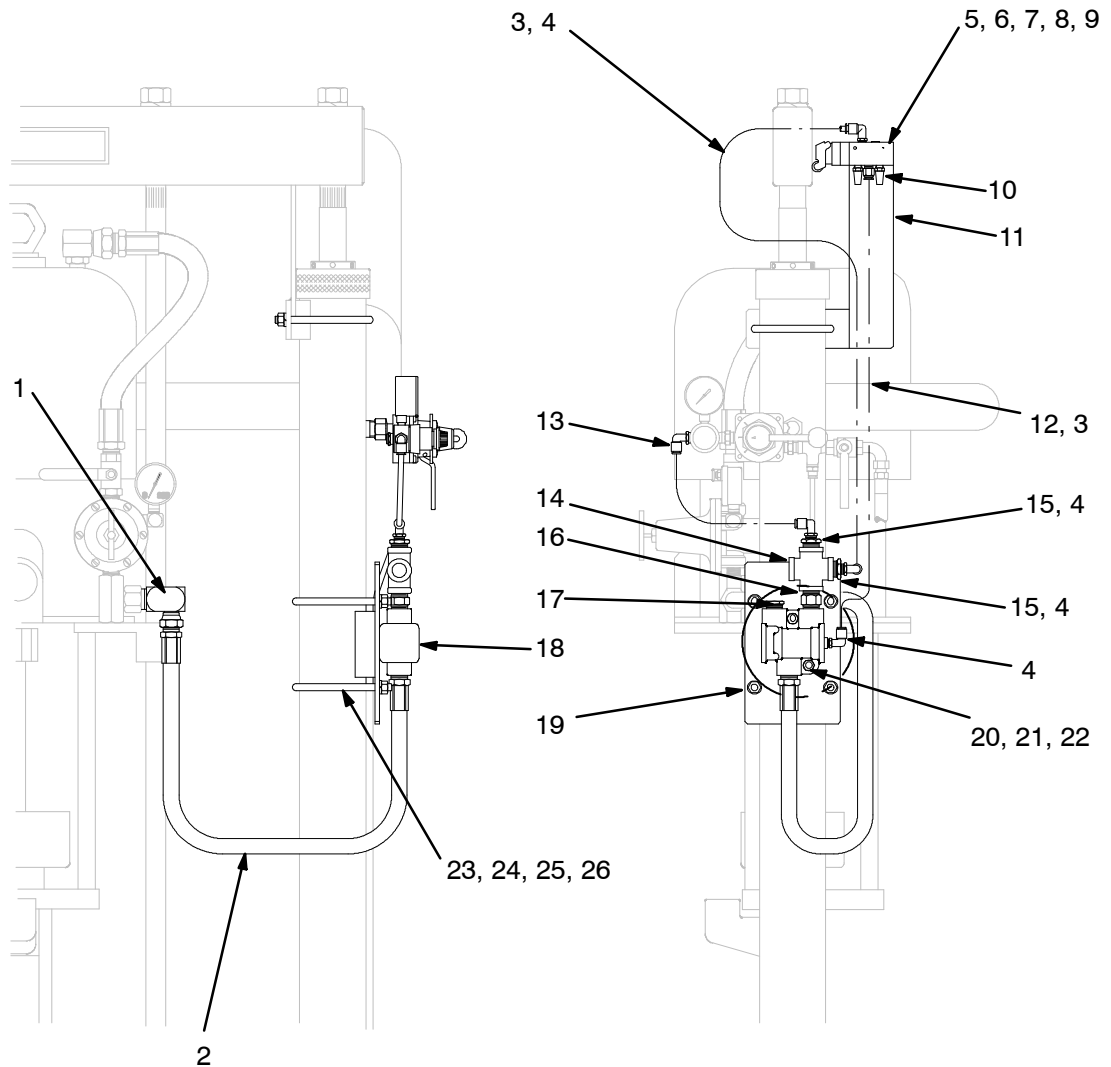

Fig. 1

# Parts

## Model 918478 Low Level Shutoff

Includes items 1-26



8586A

Ref No.	Part No.	Description	Qty	Ref No.	Part No.	Description	Qty
1	C50359	UNION, red., swivel 3/4P X 1/25	1	14	520074	PIPE, cross cs pl 1/2p	1
2	205418	HOSE, air, 1/2 I.D. 1/2P	6 ft	15	100323	BUSHING, red, hex cs pl 1/2p X 1/8p	2
3	C12509	TUBE, nylon, round, 1/4 in. OD	34 in	16	158491	NIPPLE, hex, cs pl 1/2p	1
4	111162	FITTING, 90 deg., tube 1/4t X 1/8p	4	17	517355	VENT, breather 1/2	1
5	C06182	VALVE, limit 1/8 N.P.T.	1	18	104632	VALVE, air 1/2p	1
6	C19965	SCREW, S.H.C. #6-32 X 1 1/4	2	19	C50065	PLATE, mounting	1
7	100813	WASHER, flat brass #6	4	20	111303	NUT, hex, 5/16-18	2
8	802731	WASHER, lock #6	2	21	100214	WASHER, lock, cs pl 5/16	2
9	100072	NUT, hex #6-32	2	22	102547	SCREW, cap,hex hd	2
10	C06061	MUFFLER, 1/8" N.P.T.	2	23	C24332	U-BOLT, 3/8-16	3
11	C50064	BRACKET, limit valve	1	24	C19200	WASHER, flat, 3/8	6
12	113208	FITTING, tube 1/4t X1/8p	1	25	100133	WASHER, lock, 3/8	6
13	C19391	FITTING, 90 deg., tube 1/4t X 1/4p	1	26	100307	NUT, hex 3/8-16	6

# Parts

## Model 918396 Low Level Shutoff

Includes items 1-42

Ref No.	Part No.	Description	Qty	Ref No.	Part No.	Description	Qty
1	C11037	INSERT	1	24	100721	PLUG, pipe	1
2	C11033	FILTER, air	1	25	156971	NIPPLE	1
3	C11039	INSERT, interface	1	26	104984	TEE, pipe	1
4	C11034	LUBRICATOR, air	1	27	120389	FITTING, tube	1
5	158491	NIPPLE, hex, cs pl 1/2p	2	28	104165	FITTING, tube	1
6	103475	TEE, pipe	1	30	C12509	TUBE, nylon, round, 1/4 in. OD	74 in
7	C38211	FITTING, tube	1	31	100643	SCREW, cap	2
8	C12508	TUBING; nylon	20 in.	32	100016	LOCKWASHER	2
10	156684	UNION, adapter	1	33	C11055	KIT, mounting, filter/regulator/lubricator	1
11	128863	ELBOW, swivel; 1/8 npt	3	34	104092	SCREW, cap, socket hd	4
16	100020	LOCKWASHER	10	35	112776	WASHER, plain	4
17	617351	PLATE, mounting	1	36	214656	HOSE, air, 1/2 I.D. 1/2P	6 ft
18	103926	SCREW, cap, socket hd	4	37	100896	BUSHING, pipe	1
19	617352	BRACKET, limited switch mounting	1	38	104460	SCREW, cap, socket hd	2
20	C06019	VALVE, limit	1	39	100166	NUT, hex	2
21	110826	SCREW, cap, socket hd	4	40	115126	VALVE, air, 3-way	1
22	183565	WASHER, plain	4	41	194695	PLATE, guard	1
23	100179	NUT, hex	8	42	194696	PLATE	1

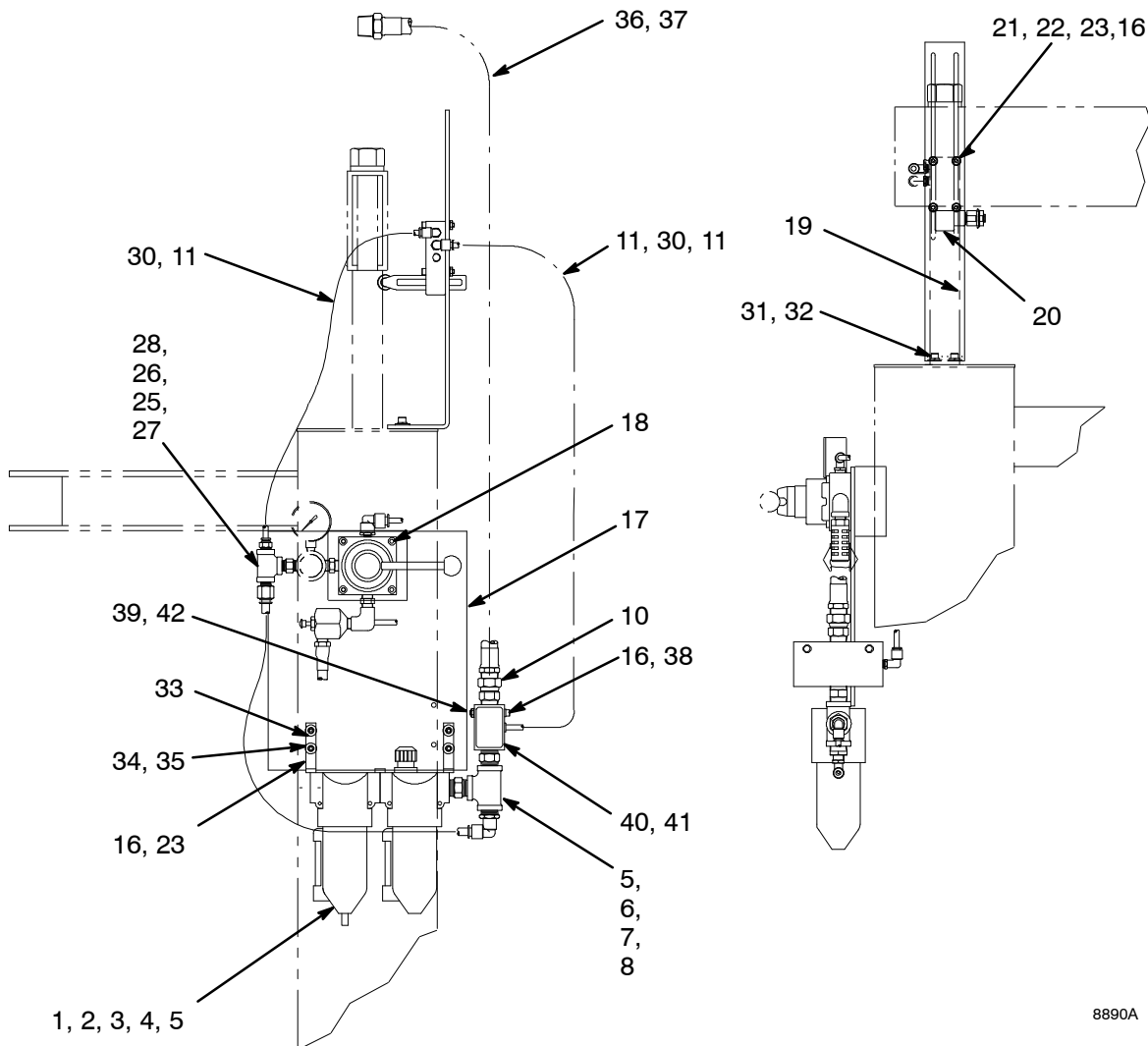

8890A

# Parts

## Model 241652 Low Level Shutoff

Includes items 1-34

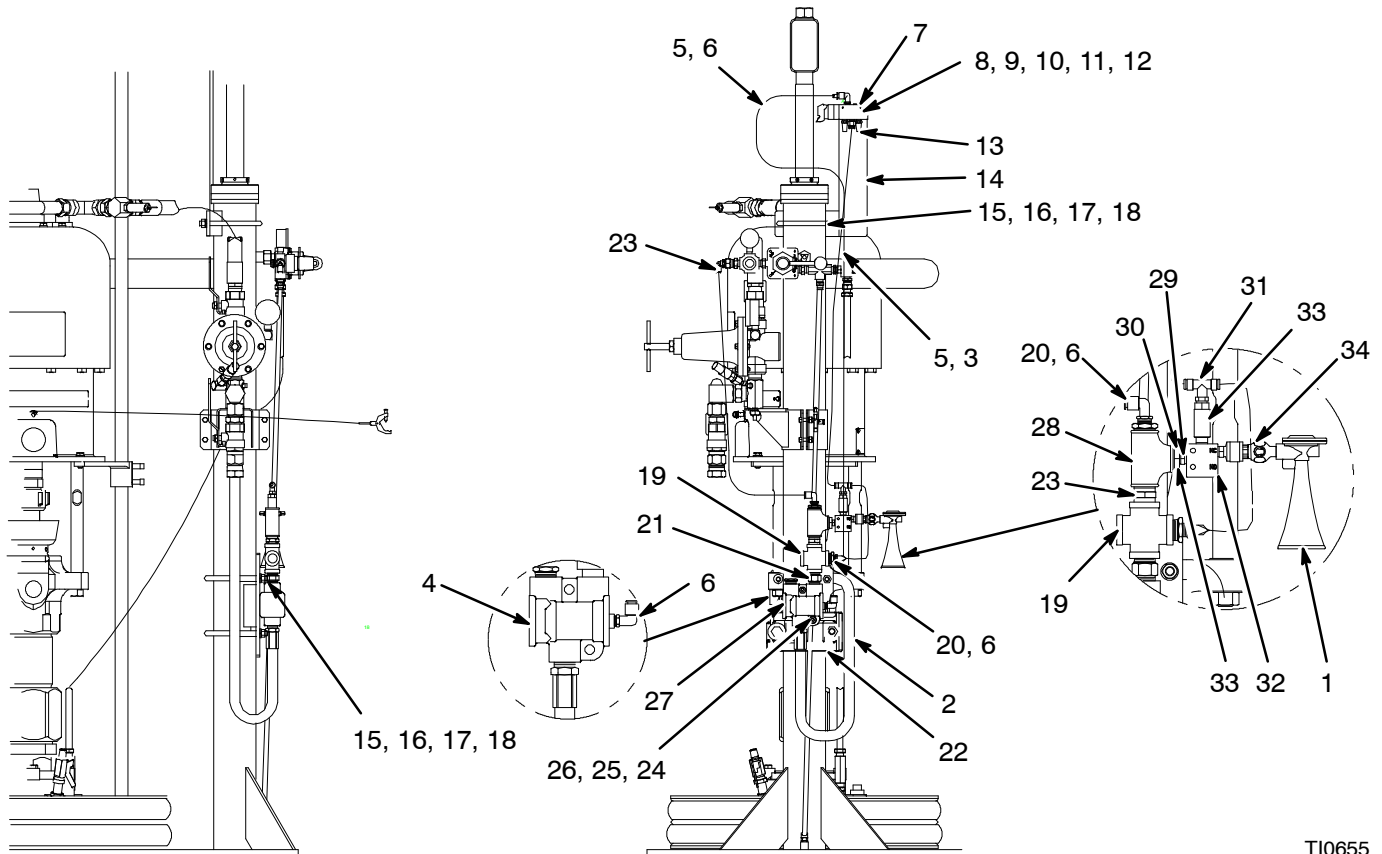

TI0655

Ref No.	Part No.	Description	Qty	Ref No.	Part No.	Description	Qty
1	511270	ALARM, air horn	1	18	100307	NUT, hex 3/8-16	6
2	205418	HOSE, air, 1/2 I.D. 1/2P	6 ft	19	520074	PIPE, cross cs pl 1/2p	1
3	113208	FITTING, tube 1/4t X1/8p	1	21	158491	NIPPLE, hex, cs pl 1/2p	2
4	104632	VALVE, air 1/2p	1	22	C50065	PLATE, mounting	1
5	C12509	TUBE, nylon, round, 1/4 in. OD	34 in	23	C19391	FITTING, 90 deg., tube 1/4t X 1/4p	1
6	111162	FITTING, 90 deg., tube 1/4t X 1/8p	4	24	101036	SCREW, cap, hex hd	2
7	100139	PLUG, pipe	1	25	100214	WASHER, lock, cs pl 5/16	2
8	C06182	VALVE, limit 1/8 NPT	1	26	111303	NUT, hex, 5/16-18	2
9	C19965	SCREW, shc #6-32 X 1 1/4	2	27	517355	VENT, breather 1/2	1
10	100813	WASHER, flat brass #6	4	28	101846	TEE, pipe	1
11	100068	WASHER, lock, spring	2	29	103656	NIPPLE, pipe, hex	2
12	100072	NUT, hex #6-32	2	30	100329	BUSHING, pipe	2
13	C06061	MUFFLER, 1/8" NPT	2	31	596832	FITTING, tee, tube	1
14	C50064	BRACKET, limit valve	1	32	502526	VALVE, air 3-way spring return	1
15	C24332	U-BOLT, 3/8-16	3	33	501014	ACTUATOR, air 1/8 NPTF	1
16	C19200	WASHER, flat, 3/8	6	34	205528	VALVE, needle	1
17	100133	WASHER, lock, 3/8	6				

# Graco Standard Warranty

Graco warrants all equipment manufactured by Graco and bearing its name to be free from defects in material and workmanship on the date of sale to the original purchaser for use. With the exception of any special, extended, or limited warranty published by Graco, Graco will, for a period of twelve months from the date of sale, repair or replace any part of the equipment determined by Graco to be defective. This warranty applies only when the equipment is installed, operated and maintained in accordance with Graco's written recommendations.

This warranty does not cover, and Graco shall not be liable for general wear and tear, or any malfunction, damage or wear caused by faulty installation, misapplication, abrasion, corrosion, inadequate or improper maintenance, negligence, accident, tampering, or substitution of non-Graco component parts. Nor shall Graco be liable for malfunction, damage or wear caused by the incompatibility of Graco equipment with structures, accessories, equipment or materials not supplied by Graco, or the improper design, manufacture, installation, operation or maintenance of structures, accessories, equipment or materials not supplied by Graco.

This warranty is conditioned upon the prepaid return of the equipment claimed to be defective to an authorized Graco distributor for verification of the claimed defect. If the claimed defect is verified, Graco will repair or replace free of charge any defective parts. The equipment will be returned to the original purchaser transportation prepaid. If inspection of the equipment does not disclose any defect in material or workmanship, repairs will be made at a reasonable charge, which charges may include the costs of parts, labor, and transportation.

**THIS WARRANTY IS EXCLUSIVE, AND IS IN LIEU OF ANY OTHER WARRANTIES, EXPRESS OR IMPLIED, INCLUDING BUT NOT LIMITED TO WARRANTY OF MERCHANTABILITY OR WARRANTY OF FITNESS FOR A PARTICULAR PURPOSE.**

Graco's sole obligation and buyer's sole remedy for any breach of warranty shall be as set forth above. The buyer agrees that no other remedy (including, but not limited to, incidental or consequential damages for lost profits, lost sales, injury to person or property, or any other incidental or consequential loss) shall be available. Any action for breach of warranty must be brought within two (2) years of the date of sale.

Graco makes no warranty, and disclaims all implied warranties of merchantability and fitness for a particular purpose in connection with accessories, equipment, materials or components sold but not manufactured by Graco. These items sold, but not manufactured by Graco (such as electric motors, switches, hose, etc.), are subject to the warranty, if any, of their manufacturer. Graco will provide purchaser with reasonable assistance in making any claim for breach of these warranties.

In no event will Graco be liable for indirect, incidental, special or consequential damages resulting from Graco supplying equipment hereunder, or the furnishing, performance, or use of any products or other goods sold hereto, whether due to a breach of contract, breach of warranty, the negligence of Graco, or otherwise.

## **FOR GRACO CANADA CUSTOMERS**

The parties acknowledge that they have required that the present document, as well as all documents, notices and legal proceedings entered into, given or instituted pursuant hereto or relating directly or indirectly hereto, be drawn up in English. Les parties reconnaissent avoir convenu que la rédaction du présente document sera en Anglais, ainsi que tous documents, avis et procédures judiciaires exécutés, donnés ou intentés à la suite de ou en rapport, directement ou indirectement, avec les procédures concernées.

## Graco Information

For the latest information about Graco products, visit [www.graco.com](http://www.graco.com).

**TO PLACE AN ORDER**, contact your Graco distributor or call to identify the distributor closest to you:

**Phone:** 612-623-6921 or **Toll Free:** 1-800-328-0211 **Fax:** 612-378-3505

*All written and visual data contained in this document reflects the latest product information available at the time of publication.  
Graco reserves the right to make changes at any time without notice.*

Original instructions. This manual contains English. MM 310294

**Graco Headquarters:** Minneapolis

**International Offices:** Belgium, China, Japan, Korea

**GRACO INC. P.O. BOX 1441 MINNEAPOLIS, MN 55440-1441**

Copyright 2002, Graco Inc. is registered to ISO 9001

[www.graco.com](http://www.graco.com)

Revised July 2020