

# XM<sup>TM</sup> PFP

## Plural-Component Sprayer

3A2989ZAF

EN

For spraying two-component passive fire protection (PFP) intumescent epoxies. For professional use only.



### Important Safety Instructions

Read all warnings and instructions in this manual and in all supplied manuals before using the equipment. Save all instructions.

*See page 3 for model information, including maximum working pressure and approvals.*

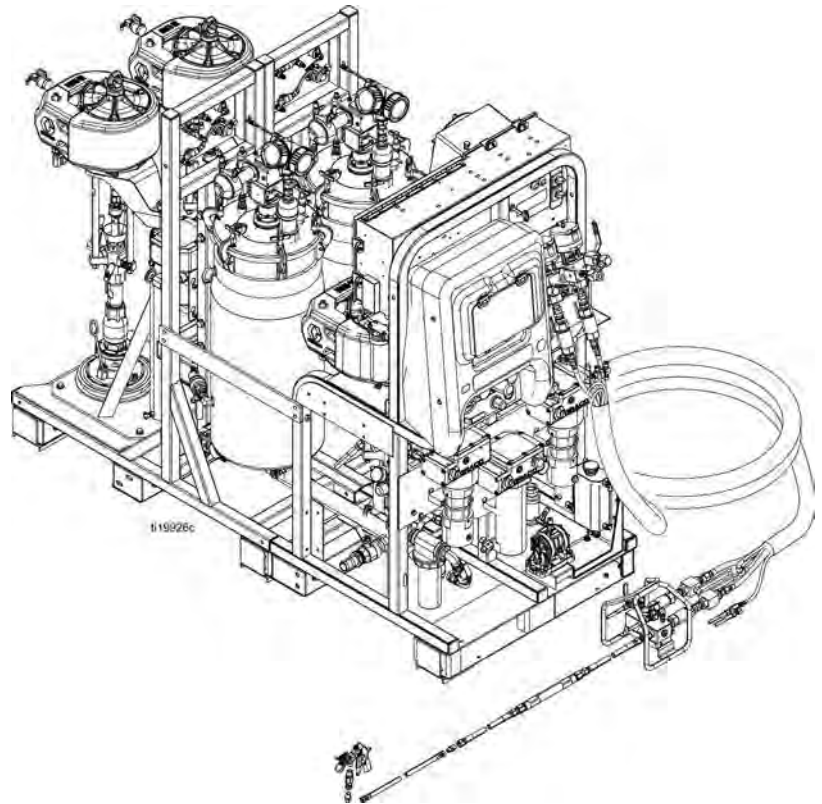

# Contents



<b>Related Manuals</b> .....	<b>2</b>
<b>Models</b> .....	<b>3</b>
<b>Warnings</b> .....	<b>4</b>
Keep Components A and B Separate .....	7
Components A and B .....	7
Changing Materials .....	7
<b>Component Identification</b> .....	<b>8</b>
<b>Grounding</b> .....	<b>8</b>
<b>Pressure Relief Procedure</b> .....	<b>9</b>
<b>Flush Mixed Material</b> .....	<b>11</b>
<b>Troubleshooting</b> .....	<b>13</b>
<b>Repair</b> .....	<b>13</b>
Replace Air Filter Element .....	13
User Interface/Control Box .....	15
Junction Box (Non-Hazardous Location Models) .....	20
Purge Box (Hazardous Location Units) .....	21
Air Controls .....	24
Dosing Valve Assembly .....	26
Sensors .....	27
Pump Assembly (System Module) .....	28
Pail Feed RAM Pump Assembly (Feed Module) .....	29
Flush Pump .....	29
Heaters .....	30
Replace Radar Level Sensor .....	31
Set Up a New Radar Level Sensor .....	32
<b>Electrical Schematics</b> .....	<b>34</b>
Non-Hazardous Location Schematic .....	34
Hazardous Location Schematics .....	41
<b>Parts</b> .....	<b>50</b>
XM PFP System Subassemblies .....	51
Base System (262878, 262941) Subassemblies .....	64
Feed Module Sub-Assemblies .....	78
Accessories .....	84
<b>Dimensions</b> .....	<b>85</b>
<b>Technical Specifications</b> .....	<b>86</b>
<b>Graco Standard Warranty</b> .....	<b>88</b>

# Related Manuals

Manuals are available at [www.graco.com](http://www.graco.com).

Manual in English	Description
3A2776	XM PFP Setup - Operation
3A2988	XM PFP Mix Manifold - Instructions - Parts
3A2799	XHF™ Spray Gun - Instructions
<b>Heaters</b>	
309524	Viscon® HP High Pressure Fluid Heater Instructions - Parts
3A2954	Viscon HF High Flow, High Pressure Fluid Heater - Instructions - Parts
<b>Pumps, Motors, Supply Systems</b>	
308553	Husky™ 307 Air-Operated Diaphragm Pumps - Instructions - Parts
308652	Husky™ 205 Air-Operated Diaphragm Pumps - Instructions - Parts
311762	Xtreme® Lowers - Instructions - Parts
312375	Check-Mate® Displacement Pumps Instructions - Parts
312376	Check-Mate Pump Packages - Instructions - Parts
312792	Merkur® Pump Repair - Parts
312794	Merkur Pump Assembly Instructions - Parts
312796	NXT Air Motor Instructions - Parts
313526	Supply Systems - Operation
313527	Supply Systems Repair - Parts
312374	Air Control Instructions - Parts
<b>Accessories</b>	
332073	Hot Water Flush Kit - Instructions
3A2987	Air Dryer Kit - Instructions
406691	Hose Rack - Parts
334931	Caster Kit - Instructions
<b>Other</b>	
313342	Dosing Valve Instructions - Parts
306861	Ball Valves Instructions - Parts
307005	High Pressure Swivel Instructions - Parts
308169	Air Filters, Lubricators, and Kits - Instructions - Parts
407061	Simulation XM PFP Display Module - Instructions
3A1244	Graco Control Architecture Module Programming - Instructions
334939	1:1 Ratio Adapter Kit - Instructions
3A3072	Heater Upgrade Kit - Instructions
3A5423	XL6500 and XL3400 Air Motors - Parts
3B0244	Overflow Tank Kit - Instructions - Parts

# Models



System	Base System	Series	Location	Ratio Range	Approvals
24W626	262878	C	Non-Hazardous	1:1 to 1.5:1	<p>Not for use in explosive atmospheres or hazardous locations.</p> 
262869				1.5:1 to 4:1	
262898					
262945	262941	B	Hazardous	1:1 to 1.5:1	
262943				1.5:1 to 4:1	









See **Technical Specifications**, page 88, for additional information.

Maximum Fluid Working Pressure	Maximum Air Working Pressure
<p><i>A and B Materials:</i> 6000 psi (41 MPa, 414 bar)</p> <p><i>Flushing Fluid:</i> 4500 psi (31 MPa, 310 bar)</p> <p><i>Heating Fluid:</i> 100 psi (0.7 MPa, 7 bar)</p>	<p><i>Supply</i> 150 psi (1.0 MPa, 10.3 bar)</p> <p><i>Maximum Setpoint</i> Main Pump: 100 psi (0.7 MPa, 7 bar) Feed Pump: 65 psi (0.45 MPa, 4.5 bar)</p>

# Warnings

The following warnings are for the setup, use, grounding, maintenance, and repair of this equipment. The exclamation point symbol alerts you to a general warning and the hazard symbols refer to procedure-specific risks. When these symbols appear in the body of this manual or on warning labels, refer back to these Warnings. Product-specific hazard symbols and warnings not covered in this section may appear throughout the body of this manual where applicable.

 <span style="font-size: 2em; font-weight: bold; margin-left: 10px;">DANGER</span>	
	<p><b>SEVERE ELECTRIC SHOCK HAZARD</b></p> <p>This equipment can be powered by more than 240 V. Contact with this voltage will cause death or serious injury.</p> <ul style="list-style-type: none"> <li>• Turn off and disconnect power at main switch before disconnecting any cables and before servicing equipment.</li> <li>• This equipment must be grounded. Connect only to grounded power source.</li> <li>• All electrical wiring must be done by a qualified electrician and comply with all local codes and regulations.</li> </ul>

 <span style="font-size: 2em; font-weight: bold; margin-left: 10px;">WARNING</span>	
  	<p><b>SPECIAL CONDITIONS FOR SAFE USE</b></p> <ul style="list-style-type: none"> <li>• Potential risk of electrostatic discharge. See instructions for guidance to minimize the risk of electrostatic discharge.</li> <li>• The system must be earthed using copper conductors according to the installation instructions. All intrinsically safe circuits must be connected to ground at one point.</li> <li>• For information on the required dimensions of the flameproof joints contact the holder of this certificate (Graco Inc.); Flame-path joints are not intended to be repaired.</li> <li>• Special fasteners for securing equipments covers on the flameproof heaters shall have a minimum yield strength of 1,100 MPa and be corrosion resistant and sized M8 x 1.25 x 30.</li> </ul>
   	<p><b>FIRE AND EXPLOSION HAZARD</b></p> <p>Flammable fumes, such as solvent and paint fumes, in <b>work area</b> can ignite or explode. Paint or solvent flowing through the equipment can cause static sparking. To help prevent fire and explosion:</p> <ul style="list-style-type: none"> <li>• Use equipment only in well ventilated area.</li> <li>• Eliminate all ignition sources; such as pilot lights, cigarettes, portable electric lamps, and plastic drop cloths (potential static sparking).</li> <li>• Ground all equipment in the work area. See <b>Grounding</b> instructions.</li> <li>• Never spray or flush solvent at high pressure.</li> <li>• Keep work area free of debris, including solvent, rags and gasoline.</li> <li>• Do not plug or unplug power cords, or turn power or light switches on or off when flammable fumes are present.</li> <li>• Use only grounded hoses.</li> <li>• Hold gun firmly to side of grounded pail when triggering into pail. Do not use pail liners unless they are anti-static or conductive.</li> <li>• <b>Stop operation immediately</b> if static sparking occurs or you feel a shock. Do not use equipment until you identify and correct the problem.</li> <li>• Keep a working fire extinguisher in the work area.</li> </ul>



# WARNING



## SKIN INJECTION HAZARD

High-pressure fluid from gun, hose leaks, or ruptured components will pierce skin. This may look like just a cut, but it is a serious injury that can result in amputation. **Get immediate surgical treatment.**

- Do not spray without tip guard and trigger guard installed.
- Engage trigger lock when not spraying.
- Do not point gun at anyone or at any part of the body.
- Do not put your hand over the spray tip.
- Do not stop or deflect leaks with your hand, body, glove, or rag.
- Follow the **Pressure Relief Procedure** when you stop spraying and before cleaning, checking, or servicing equipment.
- Tighten all fluid connections before operating the equipment.
- Check hoses and couplings daily. Replace worn or damaged parts immediately.



## BURN HAZARD

Equipment surfaces and fluid that's heated can become very hot during operation. To avoid severe burns:

- Do not touch hot fluid or equipment.



## MOVING PARTS HAZARD





Moving parts can pinch, cut or amputate fingers and other body parts.

- Keep clear of moving parts.
- Do not operate equipment with protective guards or covers removed.
- Pressurized equipment can start without warning. Before checking, moving, or servicing equipment, follow the **Pressure Relief Procedure** and disconnect all power sources.





# WARNING

 	<p><b>EQUIPMENT MISUSE HAZARD</b></p> <p>Misuse can cause death or serious injury.</p> <ul style="list-style-type: none"> <li>• Do not operate the unit when fatigued or under the influence of drugs or alcohol.</li> <li>• Do not exceed the maximum working pressure or temperature rating of the lowest rated system component. See <b>Technical Specifications</b> in all equipment manuals.</li> <li>• Use fluids and solvents that are compatible with equipment wetted parts. See Technical Data in all equipment manuals. Read fluid and solvent manufacturer's warnings. For complete information about your material, request Safety Data Sheet (SDS) from distributor or retailer.</li> <li>• Do not leave the work area while equipment is energized or under pressure.</li> <li>• Turn off all equipment and follow the <b>Pressure Relief Procedure</b> when equipment is not in use.</li> <li>• Check equipment daily. Repair or replace worn or damaged parts immediately with genuine manufacturer's replacement parts only.</li> <li>• Do not alter or modify equipment. Alterations or modifications may void agency approvals and create safety hazards.</li> <li>• Make sure all equipment is rated and approved for the environment in which you are using it.</li> <li>• Use equipment only for its intended purpose. Call your distributor for information.</li> <li>• Route hoses and cables away from traffic areas, sharp edges, moving parts, and hot surfaces.</li> <li>• Do not kink or over bend hoses or use hoses to pull equipment.</li> <li>• Keep children and animals away from work area.</li> <li>• Comply with all applicable safety regulations.</li> </ul>
	<p><b>TOXIC FLUID OR FUMES HAZARD</b></p> <p>Toxic fluids or fumes can cause serious injury or death if splashed in the eyes or on skin, inhaled, or swallowed.</p> <ul style="list-style-type: none"> <li>• Read Safety Data Sheets (SDSs) to know the specific hazards of the fluids you are using.</li> <li>• Store hazardous fluid in approved containers, and dispose of it according to applicable guidelines.</li> </ul>
	<p><b>SPLATTER HAZARD</b></p> <p>Hot or toxic fluid can cause serious injury if splashed in the eyes or on skin. During blow off of platen, splatter may occur.</p> <ul style="list-style-type: none"> <li>• Use minimum air pressure when removing platen from drum.</li> </ul>
	<p><b>PERSONAL PROTECTIVE EQUIPMENT</b></p> <p>Wear appropriate protective equipment when in the work area to help prevent serious injury, including eye injury, hearing loss, inhalation of toxic fumes, and burns. Protective equipment includes but is not limited to:</p> <ul style="list-style-type: none"> <li>• Protective eyewear, and hearing protection.</li> <li>• Respirators, protective clothing, and gloves as recommended by the fluid and solvent manufacturer.</li> </ul>

## Keep Components A and B Separate



Cross-contamination can result in cured material in fluid lines which could cause serious injury or damage equipment. To prevent cross-contamination:

- **Never** interchange component A and component B wetted parts.
- Never use solvent on one side if it has been contaminated from the other side.

## Components A and B

### IMPORTANT!

Material suppliers can vary in how they refer to plural component materials.

Be aware that in this manual:

**Component A** refers to resin or major volume.

**Component B** refers to the hardener or minor volume.

This equipment doses the B component into the A component flow. An integration hose must always be used after the mix manifold and before the static mixer.

## Changing Materials

### NOTICE

Changing the material types used in your equipment requires special attention to avoid equipment damage and downtime.

- When changing materials, flush the equipment multiple times to ensure it is thoroughly clean.
- Always clean the fluid inlet strainers after flushing.
- Check with your material manufacturer for chemical compatibility.
- When changing between epoxies and urethanes or polyureas, disassemble and clean all fluid components and change hoses. Epoxies often have amines on the B (hardener) side. Polyureas often have amines on the B (resin) side.

# Component Identification

See sprayer Setup - Operation manual for component identification, **Related Manuals**, page 2.

## Grounding



The equipment must be grounded to reduce the risk of static sparking and electric shock. All internal earth grounding must use only copper wires. See **Electrical Schematics**, page 34, for wire size. Electric or static sparking can cause fumes to ignite or explode. Improper grounding can cause electric shock. Grounding provides an escape wire for the electric current.

All components shipped from the factory are electrically bonded through ground wires. Ground the electrical connection properly according to local codes.

# Pressure Relief Procedure



Follow the Pressure Relief Procedure whenever you see this symbol.

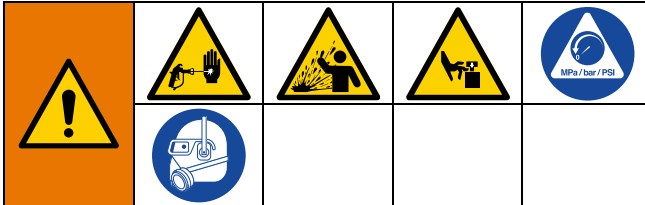

This equipment stays pressurized until pressure is manually relieved. To help prevent serious injury from pressurized fluid, such as skin injection, splashing fluid and moving parts, follow the Pressure Relief Procedure when you stop spraying and before cleaning, checking, or servicing the equipment.

1. Engage trigger lock.

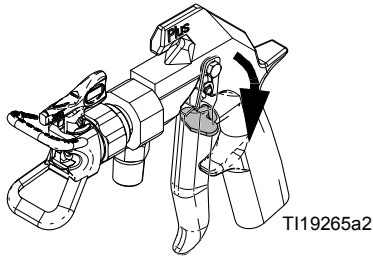

2. If the system will be shut down for more than a few hours, perform **Park Fluid Pump Rods** procedure in XM PFP Operation manual to prevent fluid hardening on the pump shaft.

3. Press  (Stop button).

4. Slide the feed pump air supply valve (DF) and director valve air supply valve (DA) to the OFF position.

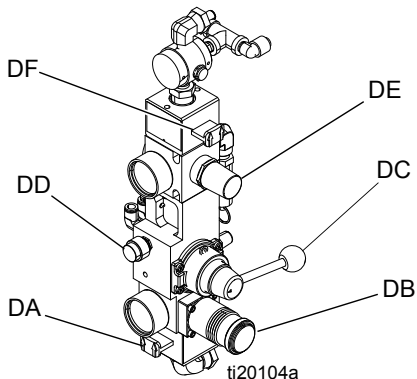
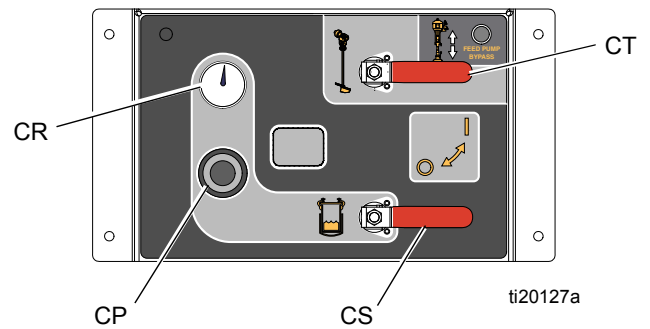

**FIG. 1: Feed Pump Controls**

## NOTICE

The material may expand when air pressure is removed. This can cause the tank to overflow and damage the parts attached to the tank lid. To prevent overflowing the tank, never relieve air pressure in the tank unless the tank is less than half full. Verify tank material level on the user interface **Supply Screen**.

5. **If necessary to relieve tank air pressure:** close both feed system air control ball valves (CT, CS) and back out the air pressure regulator (CP). Open the valves on the tank lids for full tank de-pressurization. Pressure gauge (CR) should read 0 psi.



**FIG. 2**

6. Open mix manifold ball valves.

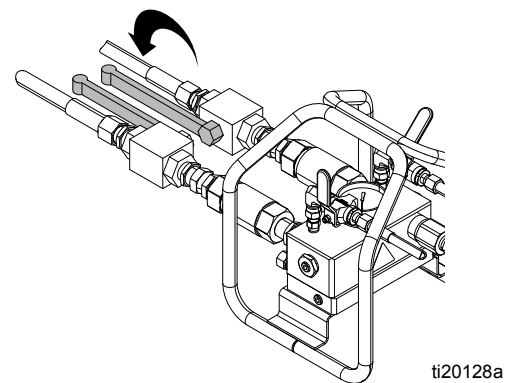

## Pressure Relief Procedure

7. Open recirculation ball valves.

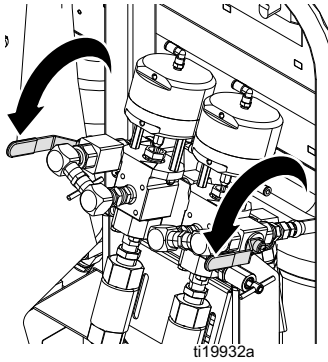

10. Engage trigger lock.

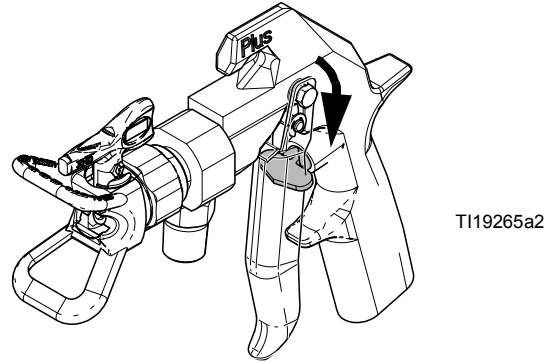

8. Disengage trigger lock.

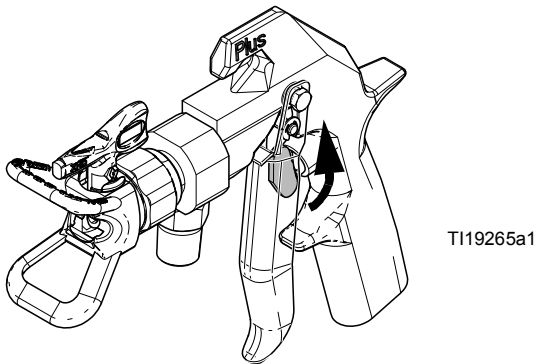

11. Close mix manifold material ball valves.

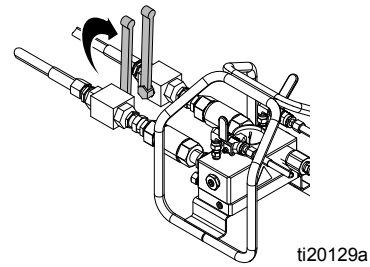

9. Hold a metal part of the gun firmly to a grounded metal pail. Trigger gun to relieve pressure in material hoses. Use a pail lid with a hole to dispense through. Seal around hole and gun with a rag to prevent splash back.

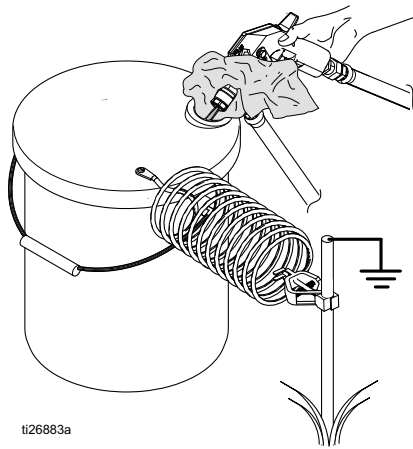

12. Perform **Flush Mixed Material** procedure on page 11 to prevent mixed material curing in the system and to relieve pressure in the solvent lines.
13. If the system will be shutdown for more than a few hours, fill pump A and B packing nuts with throat seal liquid (TSL™).

**NOTE:** Fluid pressure in the system is now relieved.

# Flush Mixed Material

To avoid fire and explosion:

- Flush equipment only in a well-ventilated area.
- Ensure main power is off and heater is cool before flushing.
- Do not turn on heater until fluid lines are clear of solvent.

This procedure flushes out mixed material from system to prevent it from curing in the system.

**NOTE:** Pot life of the mixed materials in the system is much shorter than the dry time of dispensed epoxy because mixed material pot life or working time decreases with increased temperature.

Follow this procedure when you are finished spraying if the pot life of the mixed materials in the system could expire before you spray again.

1. If necessary, **Prime Flush Pump**. See operation manual for instructions, **Related Manuals**, page 2.
2. Press to stop the metering pumps.
3. Trigger gun into a waste container to relieve pressure then engage trigger lock.
4. Remove spray tip.
5. Close mix manifold ball valves.

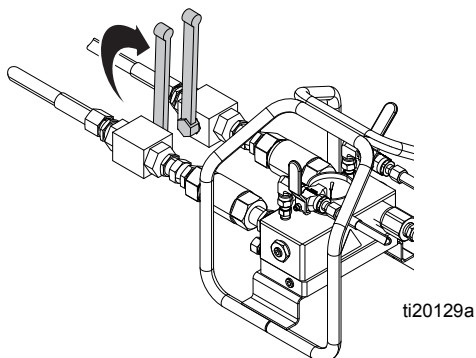

6. Open one of the flush ball valves on the mix manifold.
7. Disengage trigger lock and trigger gun into a grounded pail. Use a pail lid with a hole to dispense through. Seal around hole and gun with a rag to prevent splash back.
8. Open flush pump air supply valve (CB). Pull out and slowly turn flush pump air regulator (CG) clockwise to increase air pressure. Use lowest pressure needed to flush material out of hose.

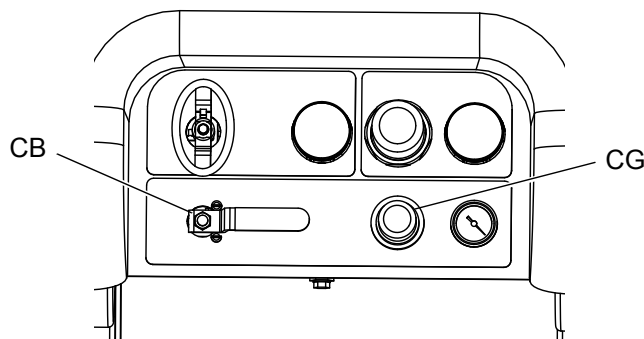

9. Continue dispensing until clean flushing fluid is dispensed.

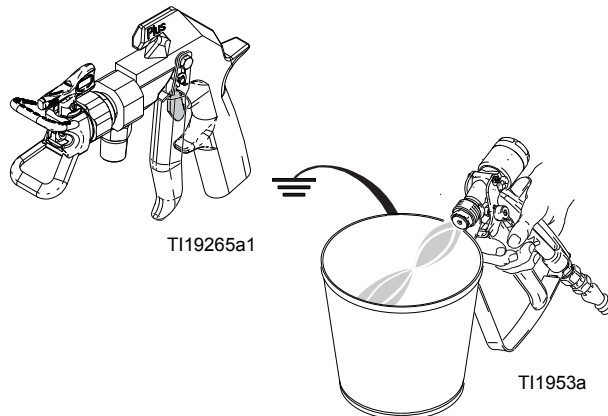

10. Close the open flush valve. Open the other flush valve. Continue dispensing long enough for any remaining mixed material.
11. Close flush pump air supply valve.

## Flush Mixed Material

12. Trigger gun to relieve pressure in flush lines then engage trigger lock.

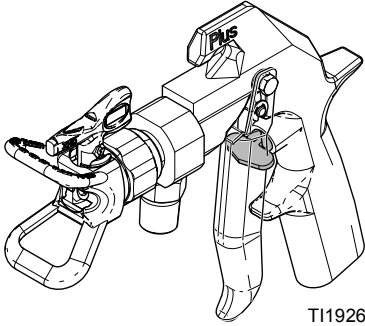

T119265a2

14. Use a rag and solvent to clean spray tip then reinstall on gun.

15. Remove the static mixer. Clean the mix element then re-install the mixer.

13. Close flush ball valves.

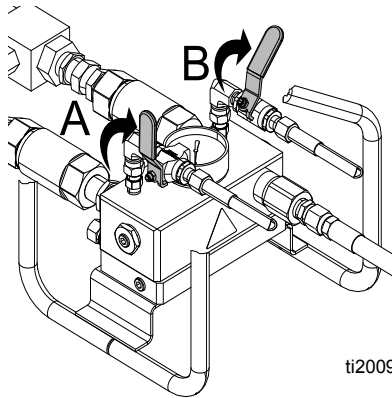

ti20095a

# Troubleshooting

See sprayer Setup - Operation manual for troubleshooting details, **Related Manuals**, page 2.

## Repair

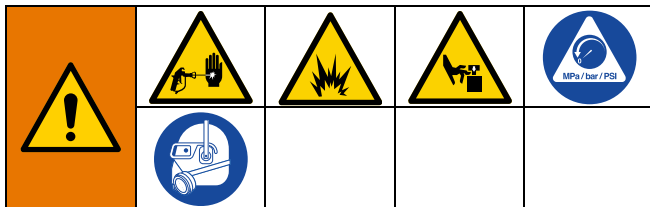

Follow **Pressure Relief Procedure** on page 9 if service time may exceed pot life time, before servicing fluid components, and before transporting sprayer.

## Replace Air Filter Element

There are two air filters on all systems: the Control Air Regulator Filter and the Main Air Inlet Manifold Filter. Hazardous location systems also have a Purge Box Air Inlet Filter. Check filters weekly and replace element as needed.

--	--	--	--	--

To reduce the risk of serious injury, do not service air filter until air line is depressurized. Removing a pressurized air filter bowl could cause serious injury.

### Control Air Regulator Filter

1. Close main air shutoff valve on air supply line and the main air shutoff valve (E).

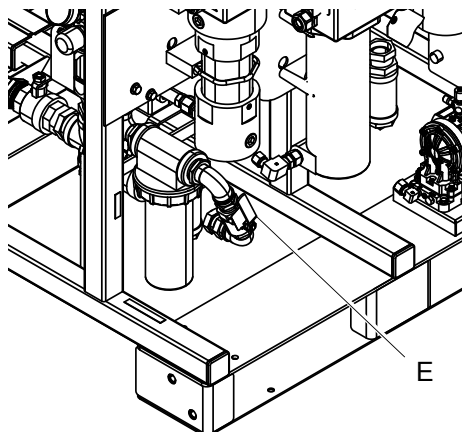

2. Remove four nuts (21) and then remove front and rear shrouds (19, 20).

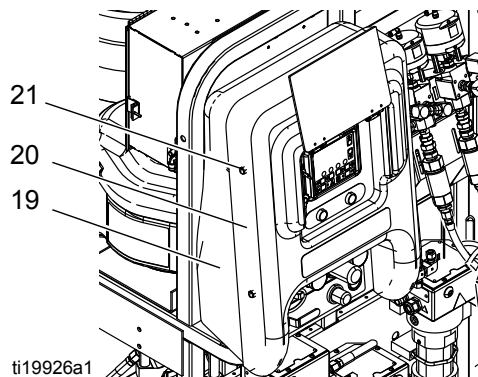

3. Unscrew filter bowl from Control Air Regulator (644), page 64.
4. Remove and replace element (644a), page 64.

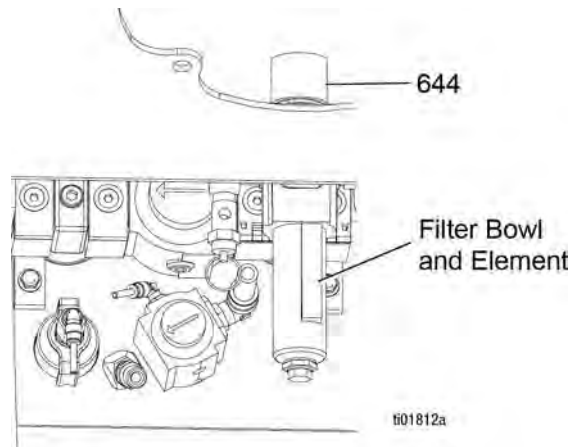

5. Screw filter bowl on securely.
6. Replace front and rear shrouds (19, 20) using four nuts (21).

### Main Air Inlet Manifold Filter

1. Close the main air shutoff valve on the air supply line and the main air shutoff valve (E).
2. Unscrew filter bowl collar from Main Air Inlet Manifold Filter (701).

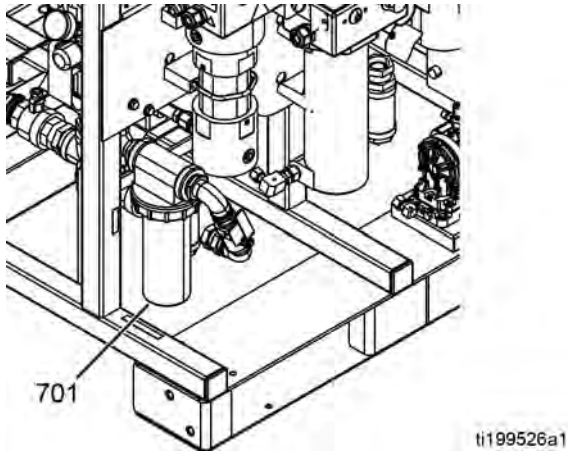

3. Remove and replace filter element (701a). See **Air Filter (24P899)**, page 78.
4. Reassemble filter bowl.

### Purge Box Air Inlet Filter

1. Close the main air shutoff valve on the air supply line and the main air shutoff valve (E).
2. Unscrew filter bowl from Purge Box Air Inlet Filter (163).

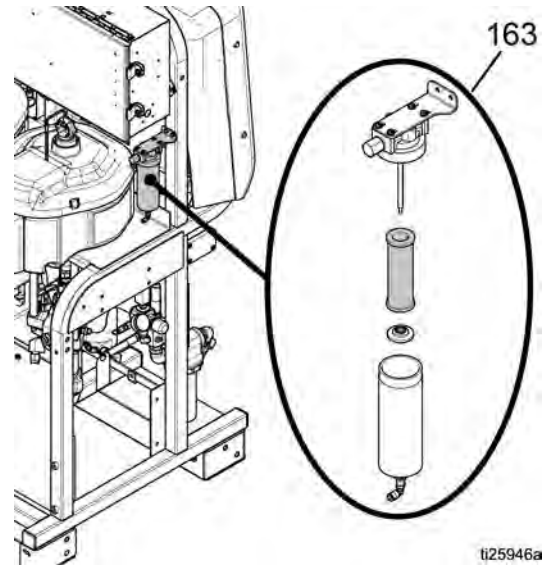

3. Remove and replace filter element (163a).
4. Reassemble filter bowl.

## User Interface/Control Box



### Remove Shroud and Front Panel of Control Box

1. Close main air shutoff valve on air supply line and on system. Depressurize air line.
2. Remove four nuts (21) and then remove front and rear shrouds (19, 20).

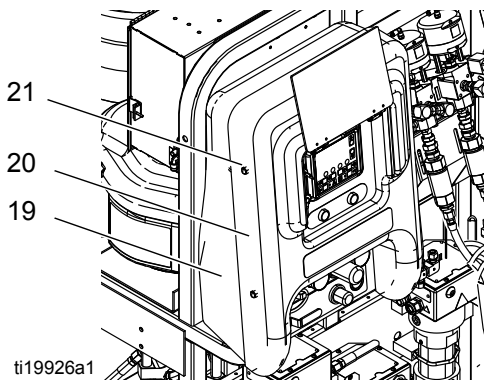

3. Remove four nuts (17); leave two nuts on left side of panel tight. Open front panel of control box (16). See FIG. 3.

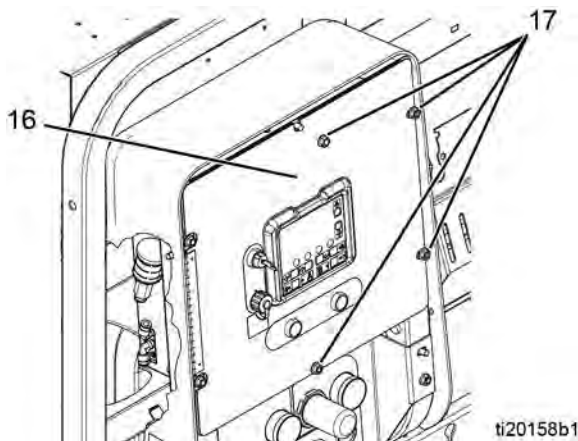

FIG. 3

### Replace Single Solenoid Module

1. Remove Shroud and Front Panel of Control Box, page 15.
2. Disconnect power.
3. Disconnect solenoid cable connector (542) from the solenoid (509a) being replaced. See **Electrical Schematics**, if necessary. For hazardous location systems see **Sensors Schematic Control Box** on page 46. For non-hazardous location systems see **Sensors Schematic Control Box** on page 38.
4. Remove two screws (509d) from the solenoid being replaced then remove solenoid (509a). See FIG. 4.

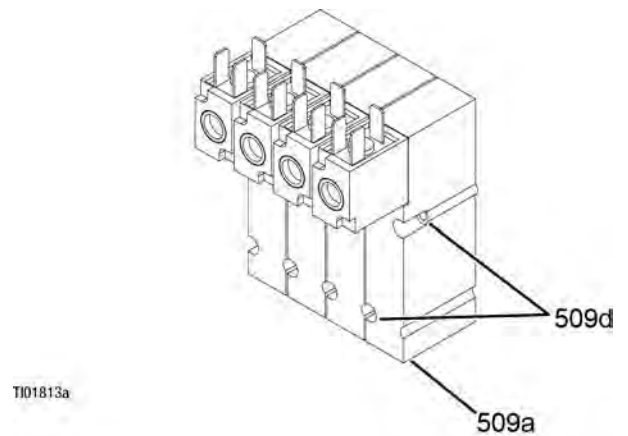
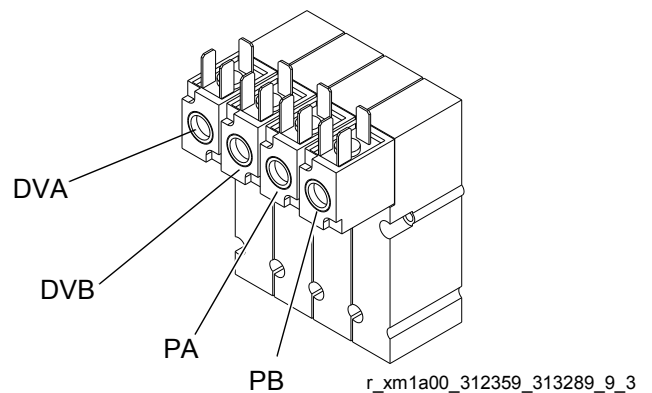

FIG. 4

5. Use screws (509d) to install new solenoid (509a).
6. Reconnect solenoid cable connectors (542).

**NOTE:** From left to right, solenoid functions are as follows:

- Dosing valve A (DVA) (normally open)
- Dosing valve B (DVB) (normally open)
- Pump A (PA) (normally closed)
- Pump B (PB) (normally closed)



## Replace USB Module

1. **Remove Shroud and Front Panel of Control Box**, page 15.
2. Disconnect power.
3. Disconnect CAN cables and USB cable from USB module (519).
4. Remove two mounting screws (555) from USB module and remove module from base. If base (519a) needs to be replaced, remove four screws (556) and ground screw (557), then remove base.

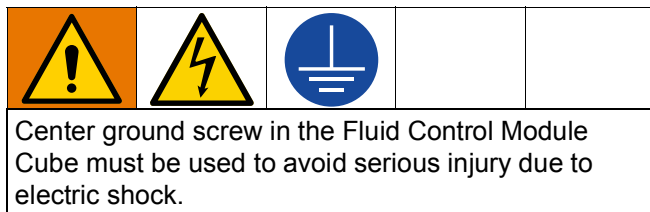
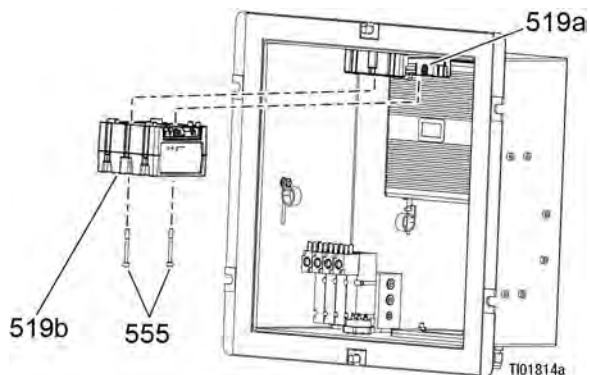

5. Follow previous steps in reverse order to install new USB module.
6. Load software. See **Upgrade Software**, page 19.
7. Reinstall front panel of control box and reinstall shrouds.

## Replace Fluid Control Module (FCM)

**NOTE:** The USB module does not need to be removed prior to replacing the FCM.

1. **Remove Shroud and Front Panel of Control Box**, page 15.
2. Disconnect power.
3. Remove all cables from FCM (507). Take note of cable locations.
4. Loosen four mounting screws (535).

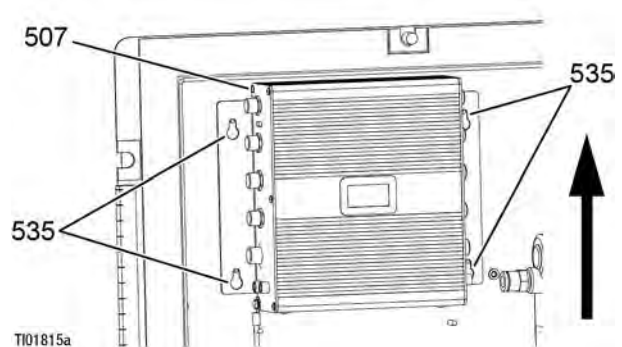

5. Slide FCM up and out of keyhole slots.
6. Follow steps in reverse order to install new FCM.
7. Load software. See **Upgrade Software**, page 19.
8. Most of the system configuration is stored in the FCM. Use the display to change the configuration to the values in the old FCM. See XM PFP operation manual for instructions.
9. Reinstall front panel of control box and reinstall shrouds.

## Replace Alarm

1. Remove Shroud and Front Panel of Control Box, page 15.
2. Disconnect power.
3. Disconnect alarm wires from alarm (517).
4. Unscrew alarm and replace.

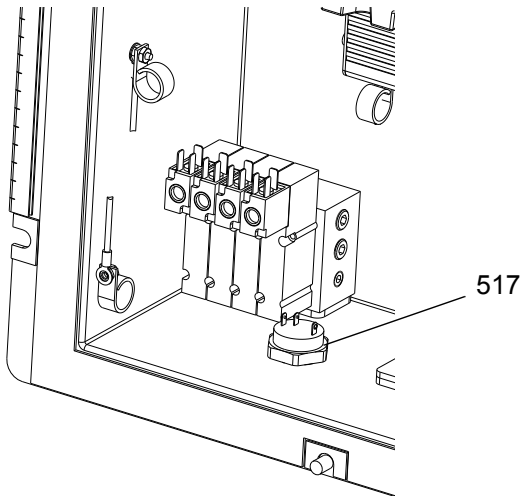

5. Screw in new alarm. Reconnect alarm wires.
6. Reinstall front panel of control box and reinstall shrouds.

## Display

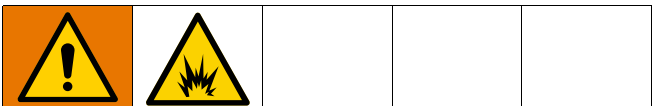

To prevent fire and explosions, do not replace the display battery in a hazardous location.

## Replace Display Battery

### NOTICE

To avoid damaging circuit board, wear a grounding strap.

1. Remove Shroud and Front Panel of Control Box, page 15.
2. Disconnect power.

3. Remove four screws (504f) then remove access cover (504e).

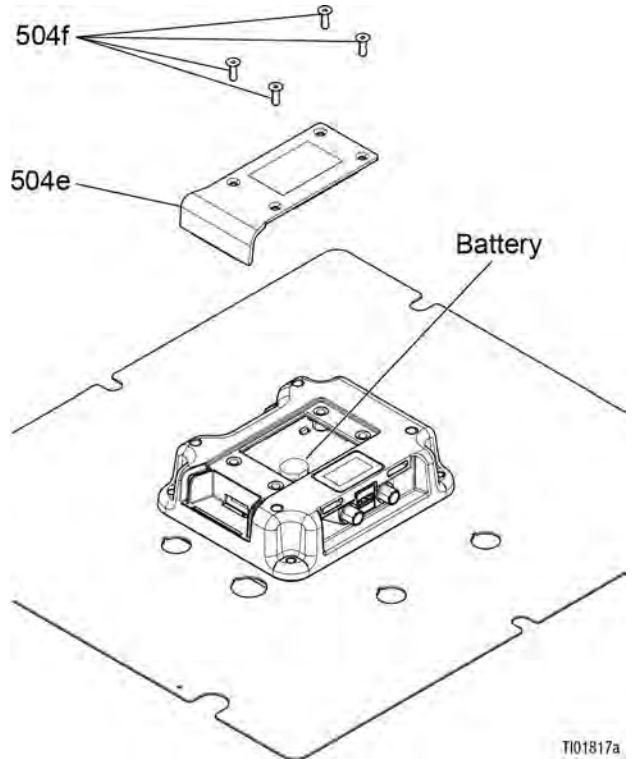

4. Use a flat head screwdriver to pry out old battery.

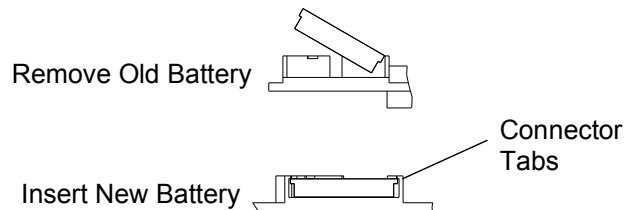

5. Replace with new battery. Ensure battery fits under connector tabs before snapping other end in place.

**NOTE:** Use only Panasonic CR2032 batteries for replacement.

6. Use screws (504f) to install access cover (504e).
7. Reinstall front panel of control box and reinstall shrouds.

## Replace Display

Order display kit (504) for replacement.

### NOTICE

To avoid damaging circuit board, wear a grounding strap.

1. **Remove Shroud and Front Panel of Control Box**, page 15.
2. Disconnect power.
3. Disconnect CAN cable from display module.
4. Remove four screws (504b) from rear display panel (504c) while holding front display panel (504d) in place.

**NOTE:** To ease removal use clear tape to hold front display panel (504d) in place.

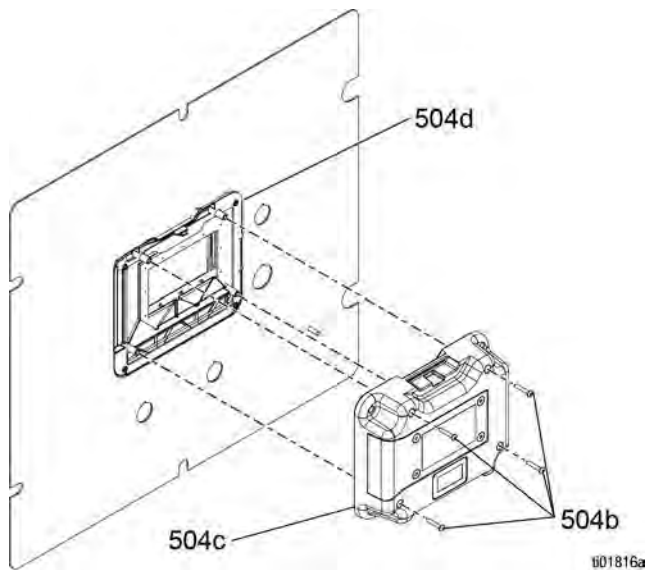

5. Remove rear display panel (504c) and disconnect display cable and key switch cable (539) from circuit board.

6. Remove front display panel (504d) and gasket (504g).

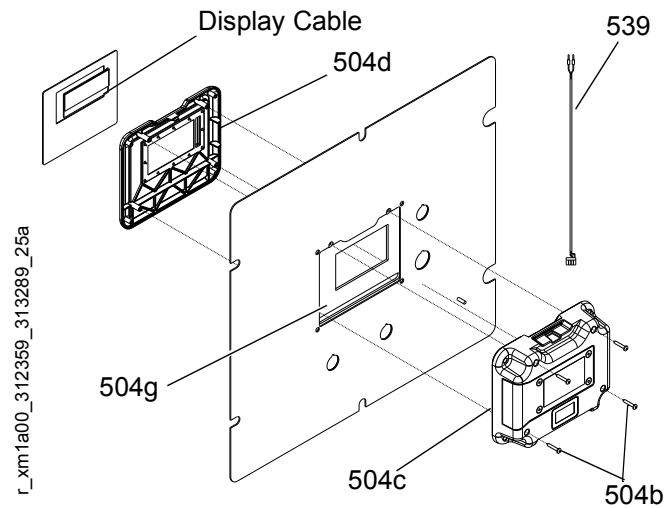

7. Discard old display assembly.
8. Place new front display panel (504d) and gasket (504g) on front panel of control box (16).

**NOTE:** To ease installation use clear tape to hold front display panel in place.

9. Carefully connect display cable and key switch cable to new circuit board.
10. Install new rear display panel (504c) and secure with four screws (504b). Ensure key switch cable protrudes from opening in top of display module.
11. Reconnect CAN cable to display module.
12. Reconnect power.
13. Load software. See **Upgrade Software**, page 19.
14. Install access cover (504e) and screws (504f).
15. Reinstall front panel of control box and reinstall shrouds.
16. Configure system settings as they were set on old display. See XM PFP Operation manual for instructions.

## Upgrade Software

1. Download all USB logs. The new software will erase the USB logs. See operation manual for instructions to Download Data from USB.
2. Turn off power to the system.
3. **Remove Shroud and Front Panel of Control Box**, page 15.
4. Remove four screws (504f) then remove access cover (504e).

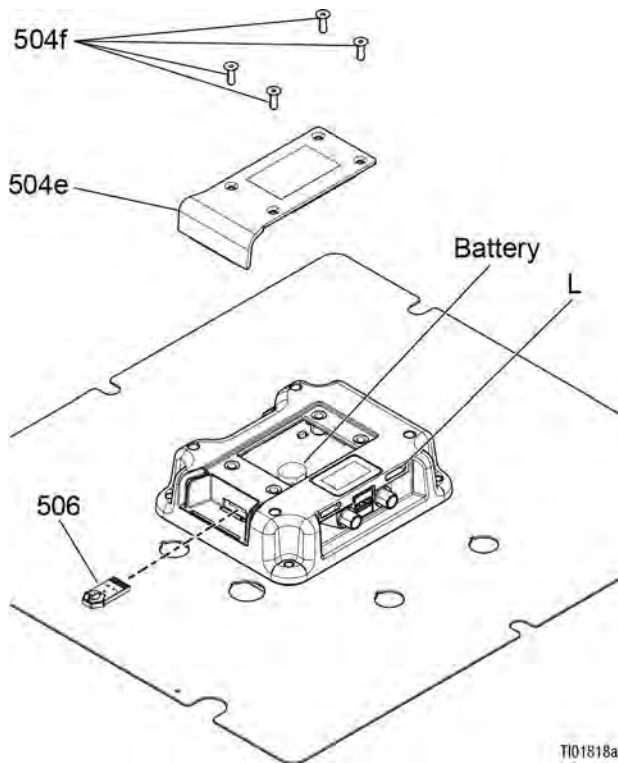



5. Insert and press token (506) firmly into slot.

**NOTE:** There is no preferred orientation of token.

6. Turn power on.
7. The red indicator light (L) will flash until new software is loaded on the display module.
8. All system modules will be automatically updated. See Graco Control Architecture Module Programming manual for details.
9. Remove token.
10. Use screws (504f) to install access cover (504e).
11. Reinstall front panel of control box and reinstall shrouds.

## Junction Box (Non-Hazardous Location Models)

				
All electrical wiring must be done by a qualified electrician and comply with all local codes and regulations.				

### Replace High Power Temperature Control Module (HPTCM)

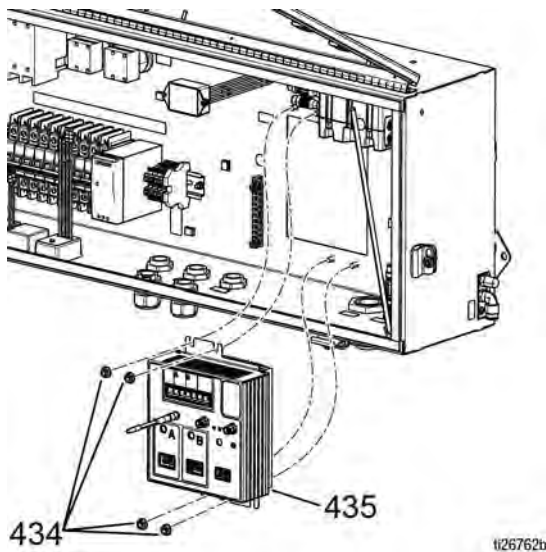

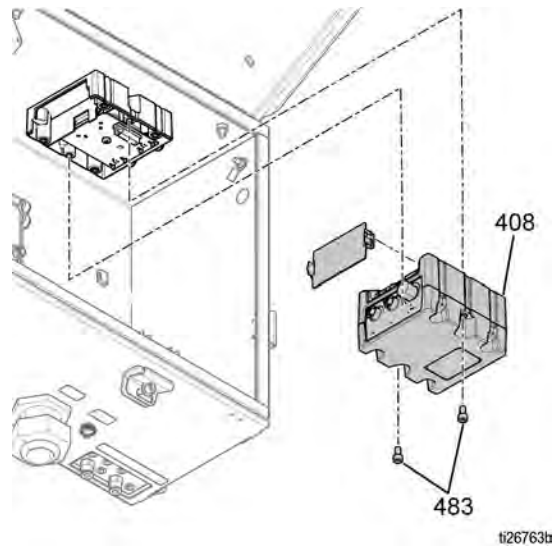

1. Turn system main power switch OFF.
2. Open junction box.
3. Unplug all connections on the HPTCM (435).
4. Remove four nuts (434) securing HPTCM then remove HPTCM.
5. Install HPTCM and reattach HPTCM connections. See **Electrical Schematics**, page 34.
6. Close junction box.
7. Load software. See **Upgrade Software**, page 19.

### Replace Fluid Control Module (FCM3)





1. Turn system main power switch OFF.
2. Open junction box.
3. Unplug all connections on the FCM3 (408).
4. Remove two screws (483) securing FCM3 then remove FCM3. If base needs to be replaced, remove four screws (406) and ground screw (407), then remove base.

				
Center ground screw in the Fluid Control Module Cube must be used to avoid serious injury due to electric shock.				

5. Follow previous steps in reverse order to install new FCM3.
6. Reattach FCM3 connections.
7. Close junction box.
8. Load software. See **Upgrade Software**, page 19.

## Purge Box (Hazardous Location Units)

				
All electrical wiring must be done by a qualified electrician and comply with all local codes and regulations.				

### Replace High Power Temperature Control Module (HPTCM)

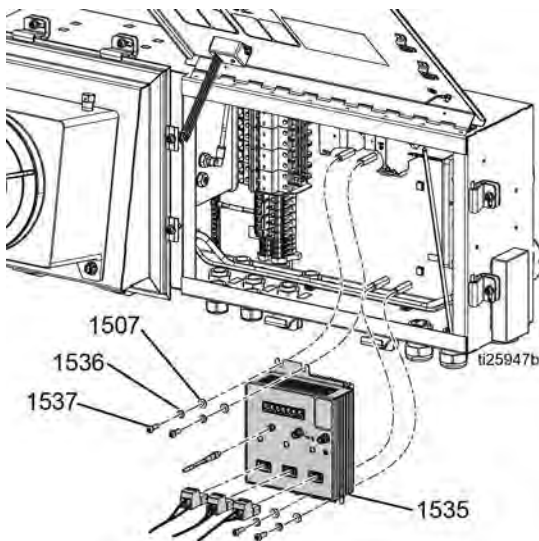

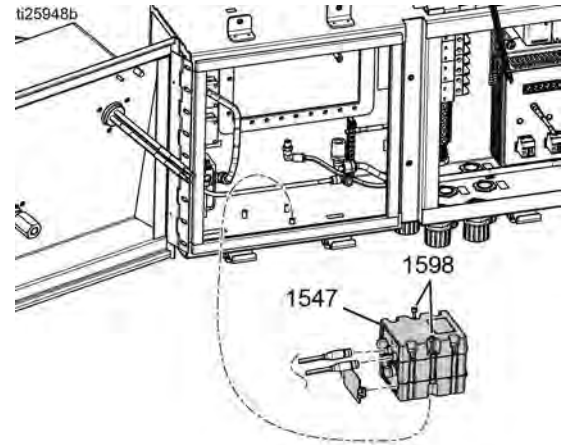

1. Turn system main power switch OFF.
2. Open purge box.
3. Unplug all connections on the HPTCM (1535).
4. Remove screws (1537) and washers (1536, 1507) securing HPTCM, then remove HPTCM.
5. Install HPTCM (1535) and reattach HPTCM connections. See **Electrical Schematics**, page 42.
6. Close purge box.
7. Load software. See **Upgrade Software**, page 19.

### Replace Fluid Control Module Cube (FCM3)



1. Turn main system power OFF by closing Metering Pump Air Control Valve.
2. Open the purge box and remove the purge controller (not shown) to access the FCM mounting screws. For removal instructions, see **Replace Purge Controller**, page 22.
3. Unplug all connections on the FCM3 (1547).
4. Loosen two screws (1598) securing FCM3 then remove FCM3. If base needs to be replaced, remove four screws (1546) and ground screw (1545), then remove base.

				
Center ground screw in the Fluid Control Module Cube must be used to avoid serious injury due to electric shock.				

5. Follow steps in reverse order to install new FCM3.
6. Reattach FCM3 connections.
7. Reinstall purge controller. See **Replace Purge Controller**, page 22.
8. Close purge box.
9. Load software. See **Upgrade Software**, page 19.

## Replace Purge Controller

**NOTE:** For hazardous location systems only.

1. Turn main system power OFF by closing Metering Pump Air Control Valve.
2. Disconnect four air tubes from the purge controller (1504).
3. Remove seven mounting screws (1504b), door (1504c), and door gasket (1504a). Remove the purge controller (1504) and gasket (1549) from the back of the purge box.
4. Install new gasket (1549) on purge controller (1504), then insert the purge controller and new gasket from the back of the purge box. Install door gasket (1504a) and door (1504c), then connect to frame with mounting screws (1504b).
5. Connect air tubes to purge controller fittings.

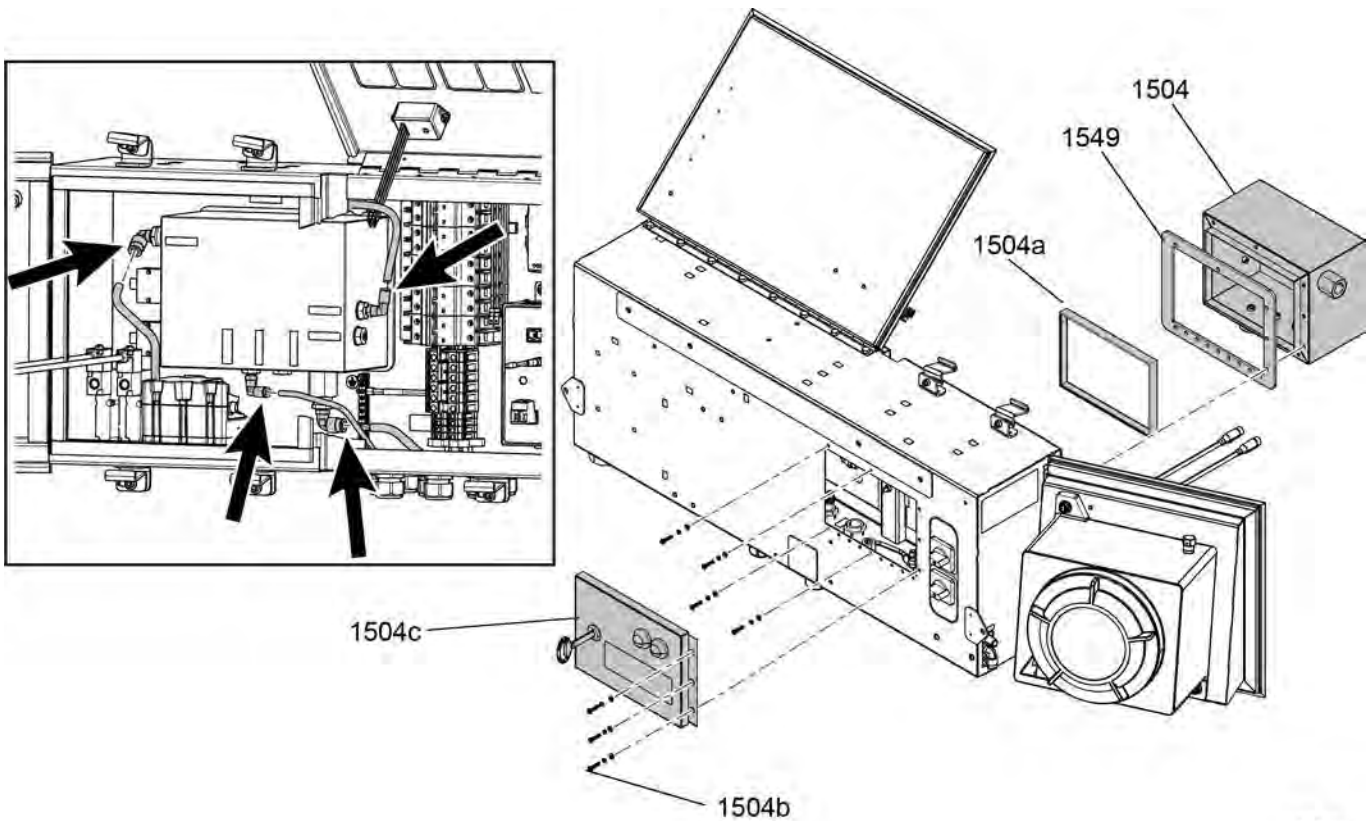

t01819a

### Multi-zone 3 Channel Barrier (For Hazardous Location Systems only)

1. Turn main power off by closing the Metering Pump Air Control Valve.
2. Open purge box.
3. Disconnect CAN cables, ground wire (1527), and air tubing from fittings.

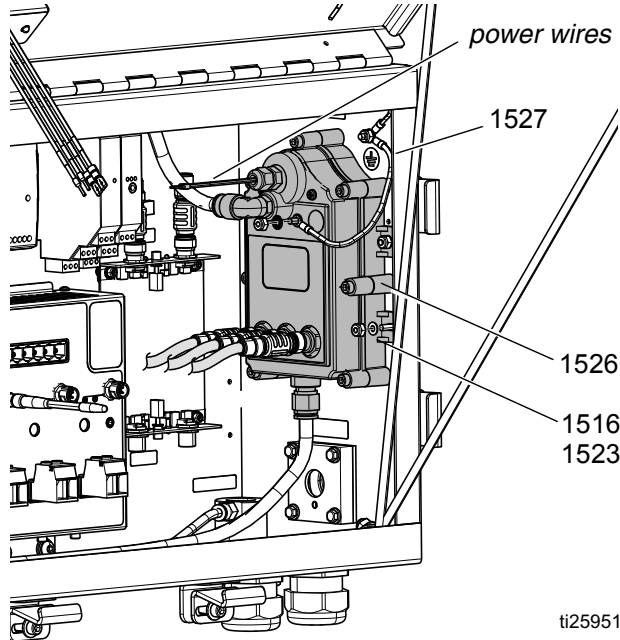

4. Disconnect red and black power wires from terminal blocks. See **CAN Network and DC Power Schematic**, page 44.
5. Remove nuts (1516) and washers (1523) and multi-zone 3 channel barrier module (1526).
6. Secure a new multi-zone 3 channel barrier module (1526) in purge box with nuts (1516) and washers (1523).
7. Reconnect the CAN cables, air tubing, ground wire, and power wiring.
8. Close purge box.

## Air Controls

### Remove Control Box Shrouds

1. Close main air shutoff valve on air supply line and on system. Depressurize air line.
2. Remove four nuts (21) and then remove front and rear shrouds (19, 20).

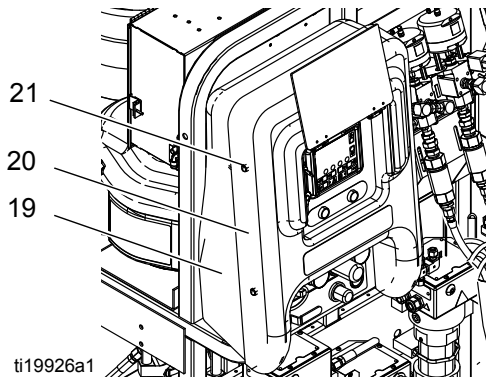

### Remove Air Control Assembly (18)

1. Remove Control Box Shrouds.
2. Disconnect air motor air lines (67) and system air line (67).
3. Remove four nuts (17) from front of air controls (18). See FIG. 5, page 25.
4. Pull out assembly (18).
5. Follow steps in reverse order to reinstall air control assembly.

### Replace Flush Pump Air Ball Valve (626)

1. Remove Air Control Assembly (18).
2. Remove two screws (630) from front of air control bracket (619). See FIG. 5, page 25.
3. Disconnect air line (632) running to ball valve assembly (626).
4. Replace with new ball valve assembly.
5. Follow steps in reverse order to reassemble.

### Replace Flush Pump Air Regulator (625)

1. Remove Air Control Assembly (18).
2. Remove regulator nut (631), and disconnect air lines (632, 633) running to regulator (625). See FIG. 5 on page 25.
3. Remove old regulator assembly (625) and replace with new regulator assembly.
4. Follow steps in reverse order to reassemble.

### Replace System Air Regulator (645)

1. Remove Air Control Assembly (18).
2. Remove regulator nut (640).
3. Remove screws from quick clamps (642) and open clamps at hinge.
4. Remove old regulator assembly (645) and replace with new regulator assembly.
5. Follow steps in reverse order to reassemble.



## Dosing Valve Assembly



1. Turn main power off.
2. Follow **Pressure Relief Procedure**, page 9.
3. Disconnect all fluid lines from dosing valves (28 or 29). See FIG. 6.
4. Open control box cover. See **User Interface/Control Box**, page 15.
5. Disconnect pressure sensor (831) from FCM (507). See **Electrical Schematics**, page 46.
6. Remove two screws (31) securing dosing valve to bracket.
7. Remove dosing valves.
8. Unscrew dosing valve nipple fitting (36 or 37) from dosing valve outlet.
9. See **Ratio Control Valve Assemblies (262887, 262888)** on page 79 for further disassembly illustration, if necessary.
10. Follow steps in reverse order to reassemble dosing valve assembly. See **Ratio Control Valve Assemblies (262887, 262888)** on page 79 for assembly illustration and specifications.

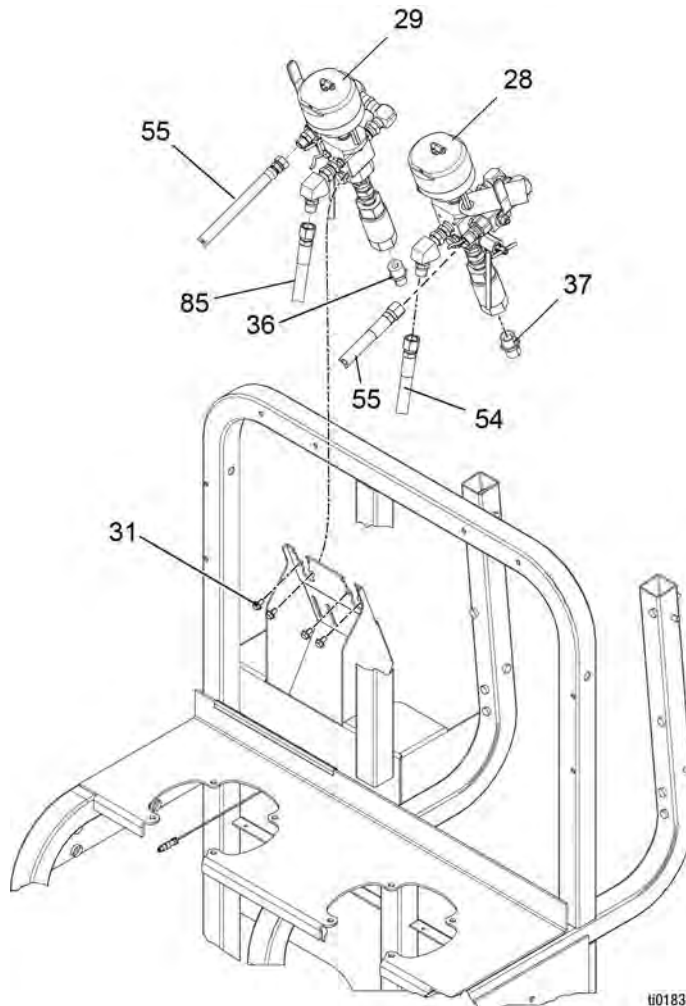

FIG. 6

t01831

## Sensors



### Replace Fluid Pressure Sensor

1. Close main air shutoff valve on air supply line and on system.
2. Follow **Pressure Relief Procedure**, page 9.
3. Open control box cover. See **User Interface/Control Box**, page 15.
4. Disconnect pressure sensor (831) from dosing valve. See **Ratio Control Valve Assemblies (262887, 262888)** on page 79.
5. Disconnect other end of pressure sensor (831) from FCM (507). See **Electrical Schematics**, page 46.
6. Follow steps in reverse order to reassemble.

### Hose Bundle Temperature Sensor (93)

1. Disconnect the M8 cable connection going into the hose bundle.
2. Open up the hose bundle wrap and insulation until sensor (93) can be removed easily without pulling on cable.
3. Remove sensor (93).

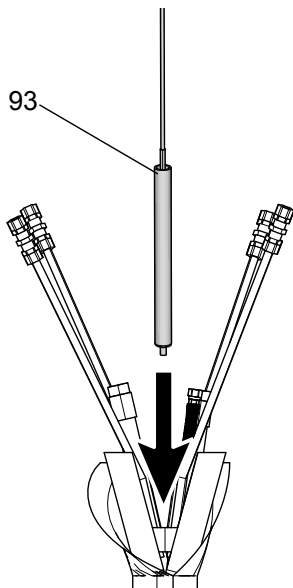

4. Push new sensor fully into insulated portion of hose bundle.
5. Close insulation and hose bundle wrap and re-tape. Ensure there is no stress on the cable.
6. Reconnect M8 connector.

### Replace Temperature (RTD) Sensors

This procedure applies to:

- Tank sensors mounted in the side of each tank near the bottom (209). See parts illustration on page 59.
- Glycol heater for hose outlet manifold sensor (100). See parts illustration on page 55.
- For material fluid heater sensors mounted inside heater housing, see your Viscon<sup>®</sup> HF heater manual, **Related Manuals**, page 2.

1. **Close main air shutoff valve** on air supply line and on system.
2. Follow **Pressure Relief Procedure**, page 9.
3. Disconnect the M8 cable connection.
4. Loosen the compression nut. Pull sensor straight out of fitting (82 or 208).
5. Remove fitting (82 or 208).

**NOTE:** The compressed ferrule cannot be removed from the sensor. A new compression fitting must be used.

6. Apply thread sealant then replace compression fitting (82 or 208). Tighten fitting in place.
7. Position sensor (100 or 209):
  - **Tank:** Insert sensor, leaving 5/8 in. (15.8 mm) sheath outside fitting.
  - **Heater manifold:** Insert sensor, leaving 1/8 in. (3.2 mm) sheath outside fitting.
8. Install compression nut on sheath hand-tight then tighten an additional 3/4 turn.

## Pump Assembly (System Module)



Prior to servicing the pump assembly you must first remove either the entire pump assembly or the displacement pump and air motor individually.

### Remove Pump Assembly

1. Follow **Pressure Relief Procedure**, page 9.
2. Close ball valve at metering pump inlet.
3. Disconnect fluid inlet line from the displacement pump. Leave line connected to the tank.
4. Disconnect air motor.
  - a. Disconnect sensor cable, air line, and ground wire from air motor.
  - b. Remove mounting screws (5) and washers (4) holding air motor (2 or 3) to mounting bracket. See FIG. 7 on page 29.
5. Use lift ring on air motor to remove pump assembly.



To avoid serious injury from falling objects caused by the lift ring breaking, do not lift pump assembly by the lift ring when the total weight of the pump assembly exceeds 550 lb (250 kg).

6. Refer to Xtreme Displacement Pump manual 311762 to service or repair the displacement pump. Refer to your XL Air Motor manual to service or repair the air motor.
7. Reconnect ground wire and sensor cable. Follow steps in reverse order to reinstall pump assembly.

### Remove Displacement Pump

Follow these instructions for removing only the displacement pump; the air motor will remain installed.

1. Follow **Pressure Relief Procedure**, page 9.
2. Close ball valve on fluid inlet line (275).
3. Disconnect fluid inlet line from the displacement pump. Leave line connected to the tank.
4. Remove clip (2b), and slide coupling cover (2c) up to remove coupling (2a).

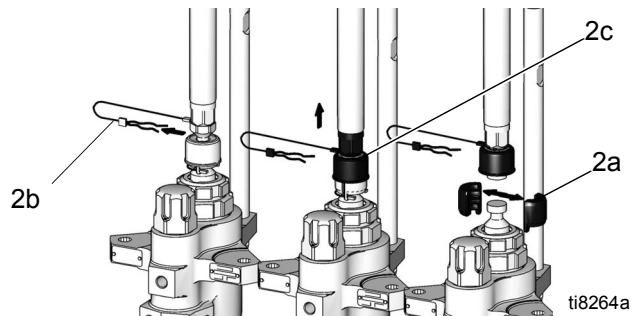

5. Use a wrench to hold the tie rod flats to keep the rods from turning. Unscrew the nuts (2e) from the tie rods (2d) and carefully remove the displacement pump (2f).

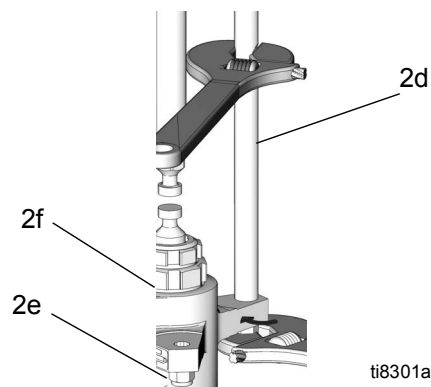

6. Refer to the Xtreme Displacement Pump manual 311762 to service or repair the displacement pump.
7. Follow steps in reverse order to reinstall displacement pump.

## Remove Air Motor

1. Follow **Pressure Relief Procedure**, page 9.
2. Disconnect displacement pump from air motor. See steps 4 and 5 under **Remove Displacement Pump**, page 28.
3. Disconnect sensor cable, air line, and ground wire from air motor.
4. Remove mounting screws (5) and washers (4) holding air motor (2 or 3) to mounting bracket.

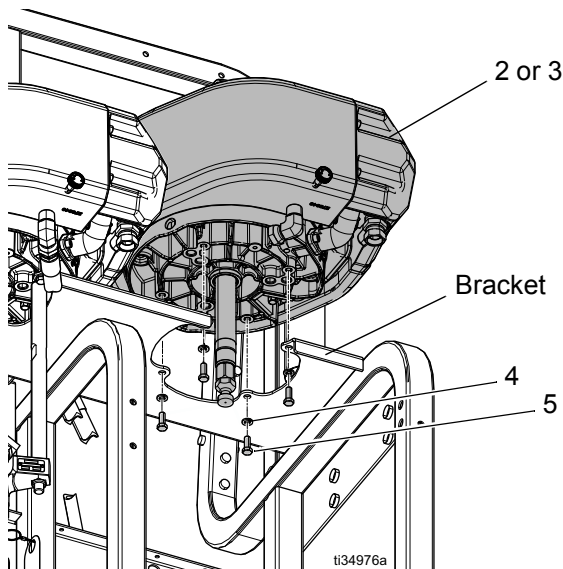

FIG. 7

5. Refer to your XL Air Motor manual to service or repair the air motor.
6. Reconnect ground wire and sensor cable. Follow steps in reverse order to reinstall air motor.

## Pail Feed RAM Pump Assembly (Feed Module)

**NOTE:** See Pail Feed RAM Pump assembly (227) in parts breakdown beginning on page 59.

See your Supply Systems manual for service and repair instructions and parts.

## Flush Pump



1. Follow **Pressure Relief Procedure**, page 9.
2. Disconnect fluid inlet line (154), fluid outlet line (57), and air line (60) from flush pump.
3. Remove four screws (153) that attach flush pump (8) to bracket (152) and remove flush pump.

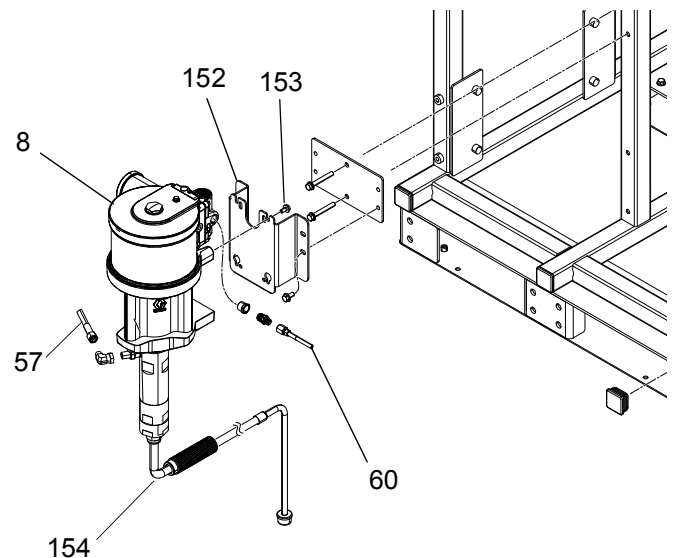

4. Refer to your Merkur Pump Assembly manual to service or repair flush pump 257463.
5. Follow steps in reverse order to reinstall flush pump.

## Heaters

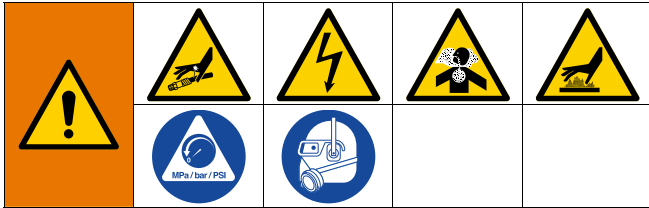

See applicable heater manual for wiring, repair, and parts information. See **Warnings** on page 4.

### Service and Repair

1. Wait for heaters to cool before beginning to repair the heaters.
2. Follow **Pressure Relief Procedure**, page 9.
3. Turn off power.
4. Disconnect fluid lines and electrical wiring from fluid heater.
5. Refer to heater manual to service or repair heater.
6. Reconnect fluid lines and electrical wiring.

### Replace

1. Wait for heaters to cool before replacing the heaters.
2. Follow **Pressure Relief Procedure**, page 9.
3. Turn off power.
4. Disconnect fluid lines and electrical wiring from fluid heater.
5. **System Module Heaters:** See FIG. 8. Loosen four mounting screws, lock washers, and plain washers on back of heater (12 or 13) that secure it to the system frame. Slide heater up and remove from mounting plate.
6. **Feed Module Heaters:** See page 60. Loosen four mounting screws, lock washers, and plain washers on back of heater (226) that secure it to the system frame. Slide heater up and remove from mounting plate.
7. Replace heater. Follow steps in reverse order to install new heater.

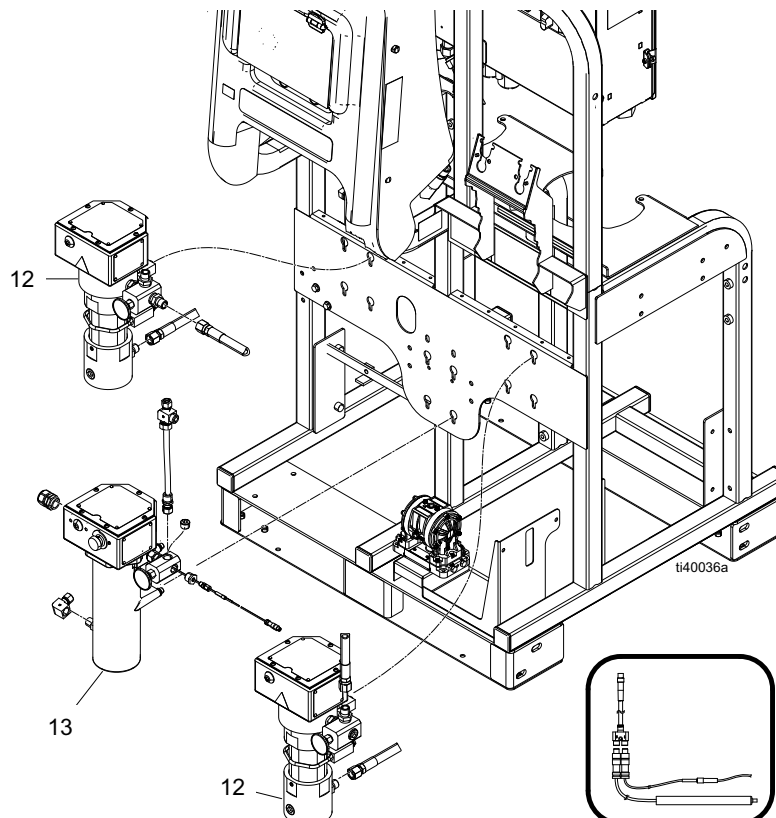

**FIG. 8: Heaters on System Module**

## Replace Radar Level Sensor



**NOTE:** Order radar level sensor kit 26C587. See **Feed Modules** on page 59 for kit contents.

**NOTE:** Tank level sensors changed in 2014. The old sensors were red. The new sensors are blue. The blue sensors can be used as direct replacements for the red sensors.

1. With the tank empty, close the tank air supply ball valve, then open the valve (1010) on the Tank Air Manifold Assembly (218) to de-pressurize the tank. See FIG. 9.

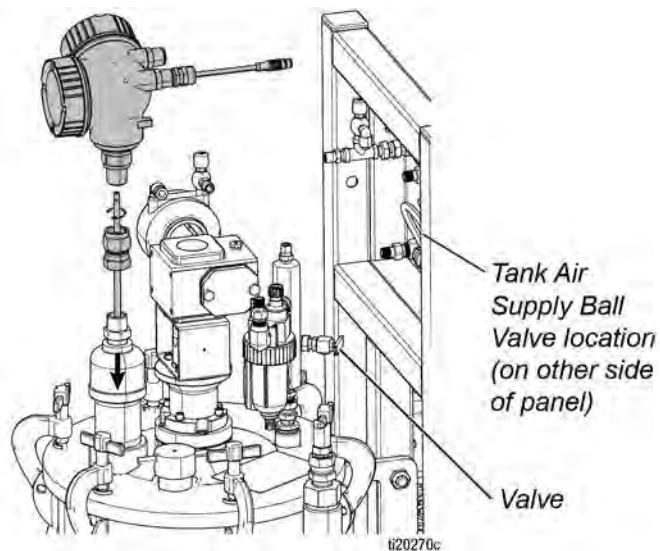

**FIG. 9: Level Sensor Installation**

2. Disconnect cable at the bottom of the feed module.  
Always use the new cable supplied with the sensor. It has different connections than the old sensor.
3. Disconnect 3/4 in. union that holds the level sensor on top of the tank.
4. Pull the old sensor straight up out of the tank.
5. Remove plugs from new sensor and discard plugs. Move fittings from old sensor to new sensor.
6. If the sensor rod was removed for shipping, apply blue thread-lock to the threads in the end of the rod.
7. Feed the rod into the sensor head and screw the threaded end into the sensor head.
8. Use a wrench to hold the 3/8 in. flats on the sensor rod. Tighten to approximately 25 - 30 in-lb (2.8 - 3.4 N•m). Do not over-tighten.
9. Reconnect sensor to tank lid using 3/4 in. union.
10. Reconnect sensor cable.
11. See **Set Up a New Radar Level Sensor**, page 32.

## Set Up a New Radar Level Sensor

Level sensors need to have three settings setup after installing on the tank of the PFP machine. The tank must be empty, or the level needs to be at least below the bottom of the installed probe with the tank cover closed.

1. Open the sensor head cover over the display:
  - a. Loosen the securing clamp with an Allen wrench (if clamp is present).
  - b. Unscrew the round cover and pull away.

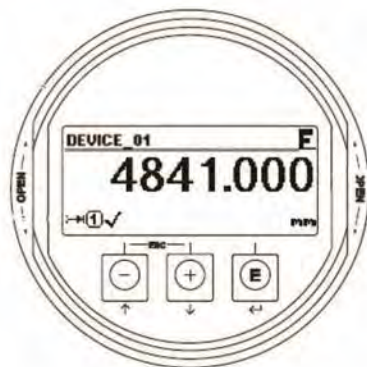
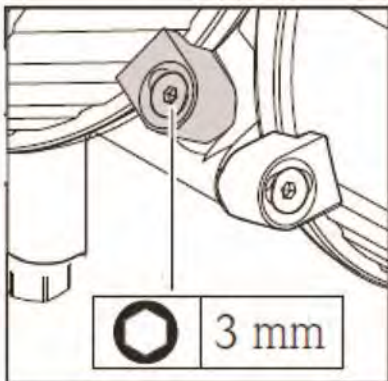

ti24380a

**NOTE:** Use the operating keys to navigate within the operating menu and to select options from a list.

Key	Meaning
	<p><b>“Minus” Key</b></p> <ul style="list-style-type: none"> <li>In a selection list, this key will move the selection bar upward.</li> <li>In an input matrix, this key will move the selection bar backward.</li> </ul>
	<p><b>“Plus” Key</b></p> <ul style="list-style-type: none"> <li>In a selection list, this key will move the selection bar downward.</li> <li>In an input matrix, this key will move the selection bar forward.</li> </ul>
	<p><b>“Enter” Key</b></p> <ul style="list-style-type: none"> <li>Opens the marked sub-menu or parameter.</li> <li>Confirms a changed parameter value.</li> </ul>
	<p><b>“Escape” Key combination (press keys simultaneously)</b></p> <ul style="list-style-type: none"> <li>Closes a parameter without accepting the changes.</li> <li>Quits the current menu layer and returns to the next higher layer.</li> </ul>

2. Turn power on the machine. Set **EMPTY CAL**, then **FULL CAL**, then do a mapping of the Empty Tank.
3. Set **EMPTY CAL** to 0.666 meters:
  - a. Press **E**, then **+**, until setup appears, then press **E**.
  - b. Press **+** until **EMPTY CAL** appears, then press **E**.
  - c. Press **+** until decimal point (.) appears, then press **E**.
  - d. Press **+** until 6 appears, then press **E**.
  - e. Press **+** until 6 appears, then press **E**.
  - f. Press **+** until 6 appears, then press **E**.
  - g. Press and hold **E** until the hourglass appears, then release.

4. Set **FULL CAL** to 0.418 meters.
  - a. Press **+** to get to **FULL CAL**, then press **E**.
  - b. Press **+** until decimal point (.) appears, then press **E**.
  - c. Press **+** until 4 appears, then press **E**.
  - d. Press **+** until 1 appears, then press **E**.
  - e. Press **+** until 8 appears, then press **E**.
  - f. Press and hold **E** until the hourglass appears, then release.
5. Map **EMPTY TANK**.
  - a. Press **+** to get to **MAPPING**, then press **E**.
  - b. Press **+** to get to **CONFIRM DISTANCE**, then press **E**.
  - c. Press **+** until **TANK EMPTY** appears, then press **E**.
  - d. Press **+** under the check mark to confirm, **END OF SEQUENCE** will appear. Press **E**.
  - e. You are now finished. Press **+** and **-** together to go back. Repeat until Main Screen appears.
6. The transmitter display should show nothing in the tank. Check the level display on the PFP machine control. It should also show the tank as empty.
7. These settings can now be locked from display control so they will not be inadvertently changed.
8. Set display to lock ON:
  - a. Turn display counter-clockwise to release it as shown below (2).
  - b. Set the dip switch to the lock position as shown below (3).
  - c. Replace display.
  - d. Replace screw on lid.
  - e. Engage cover securing clamp (if clamp is present).

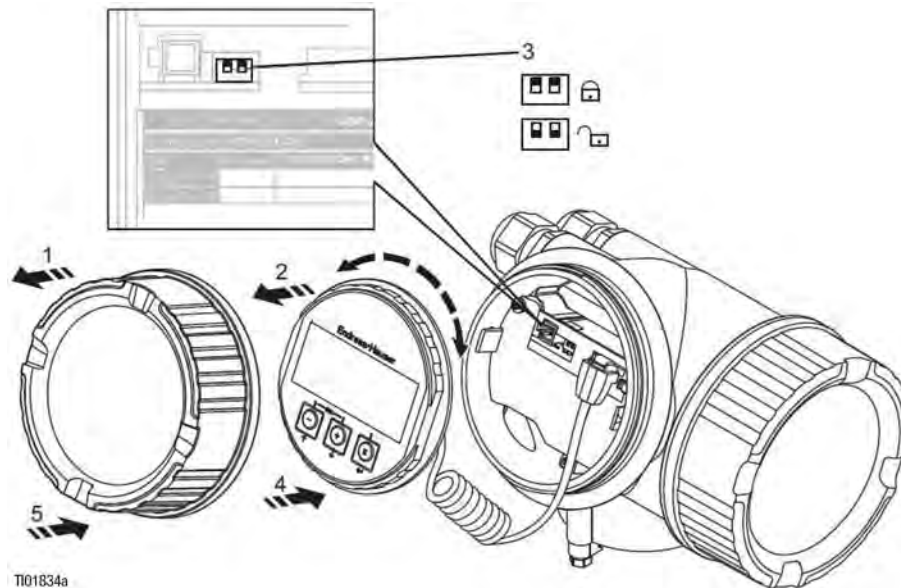

# Electrical Schematics

## Non-Hazardous Location Schematic

### AC Power Schematic

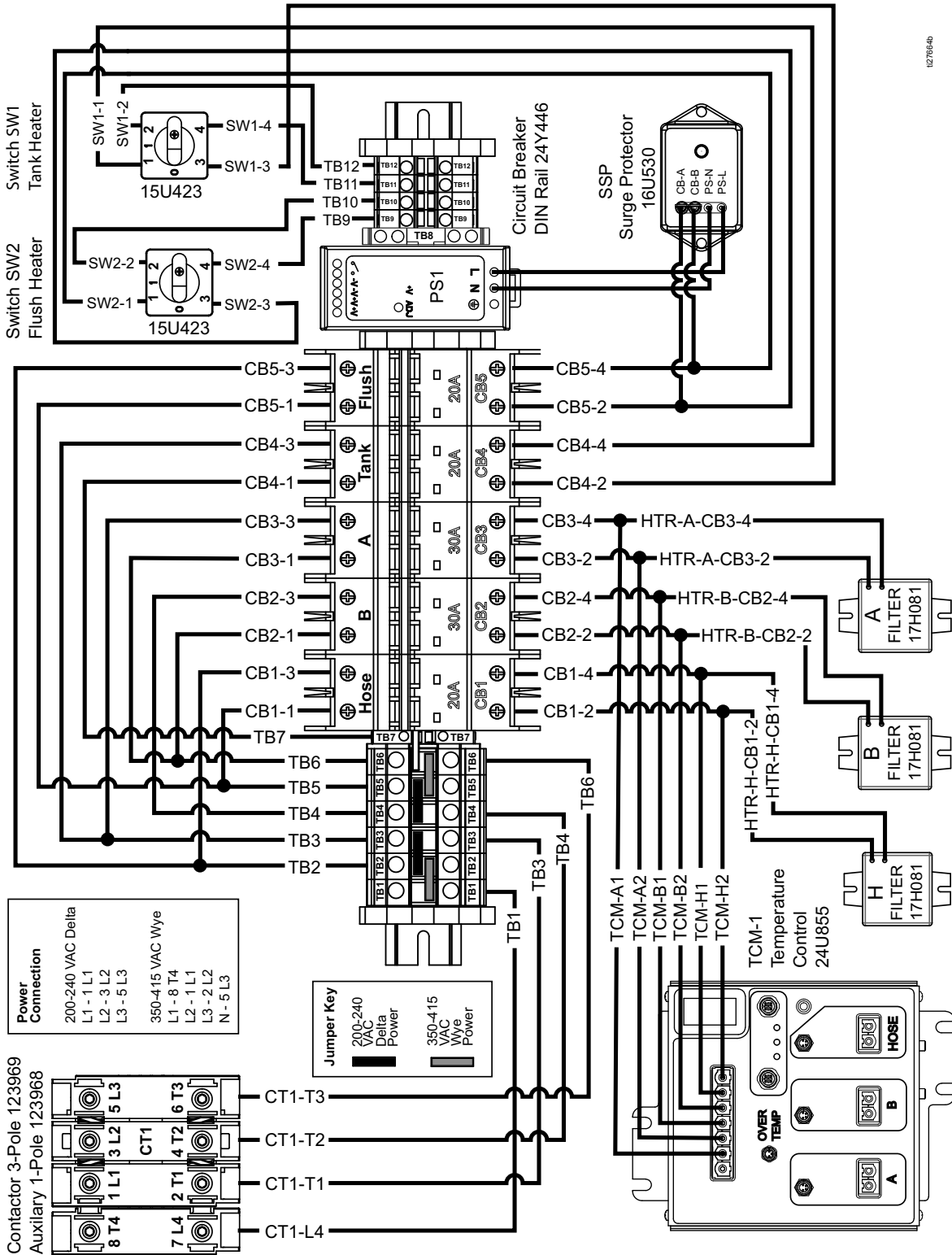

1278540

Heater Schematic

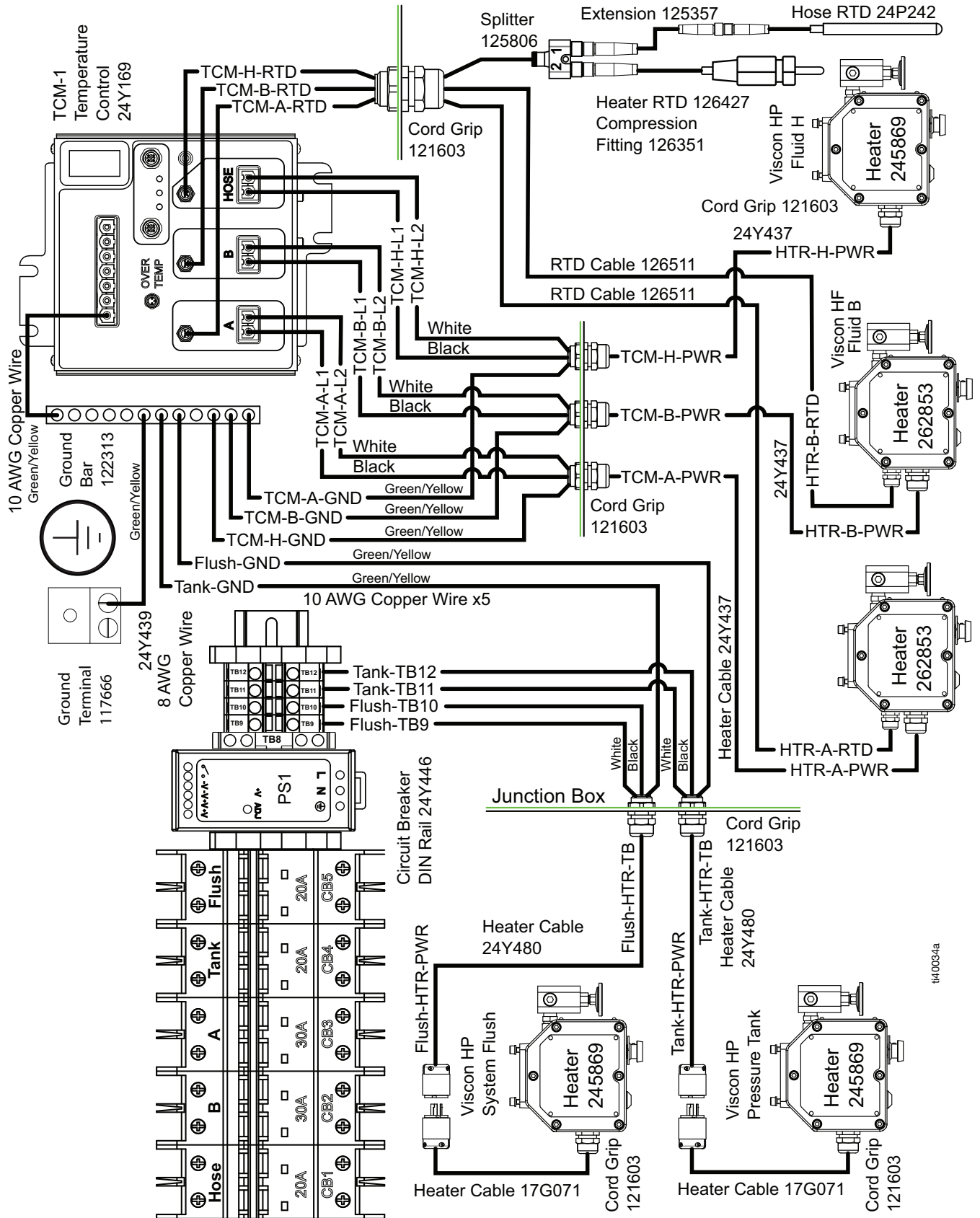

14-0034a

CAN Network Schematic

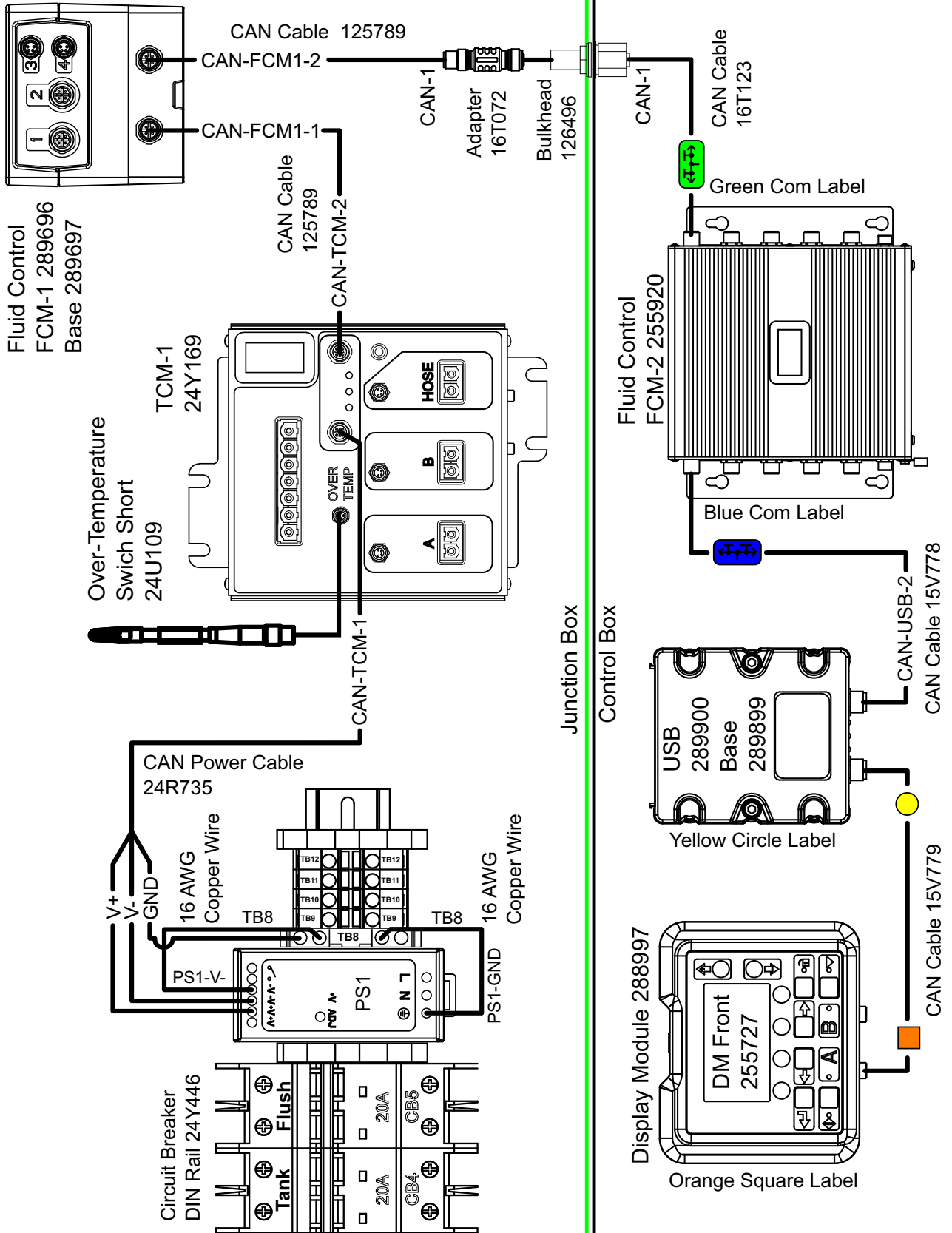

Sensor Schematic Junction Box

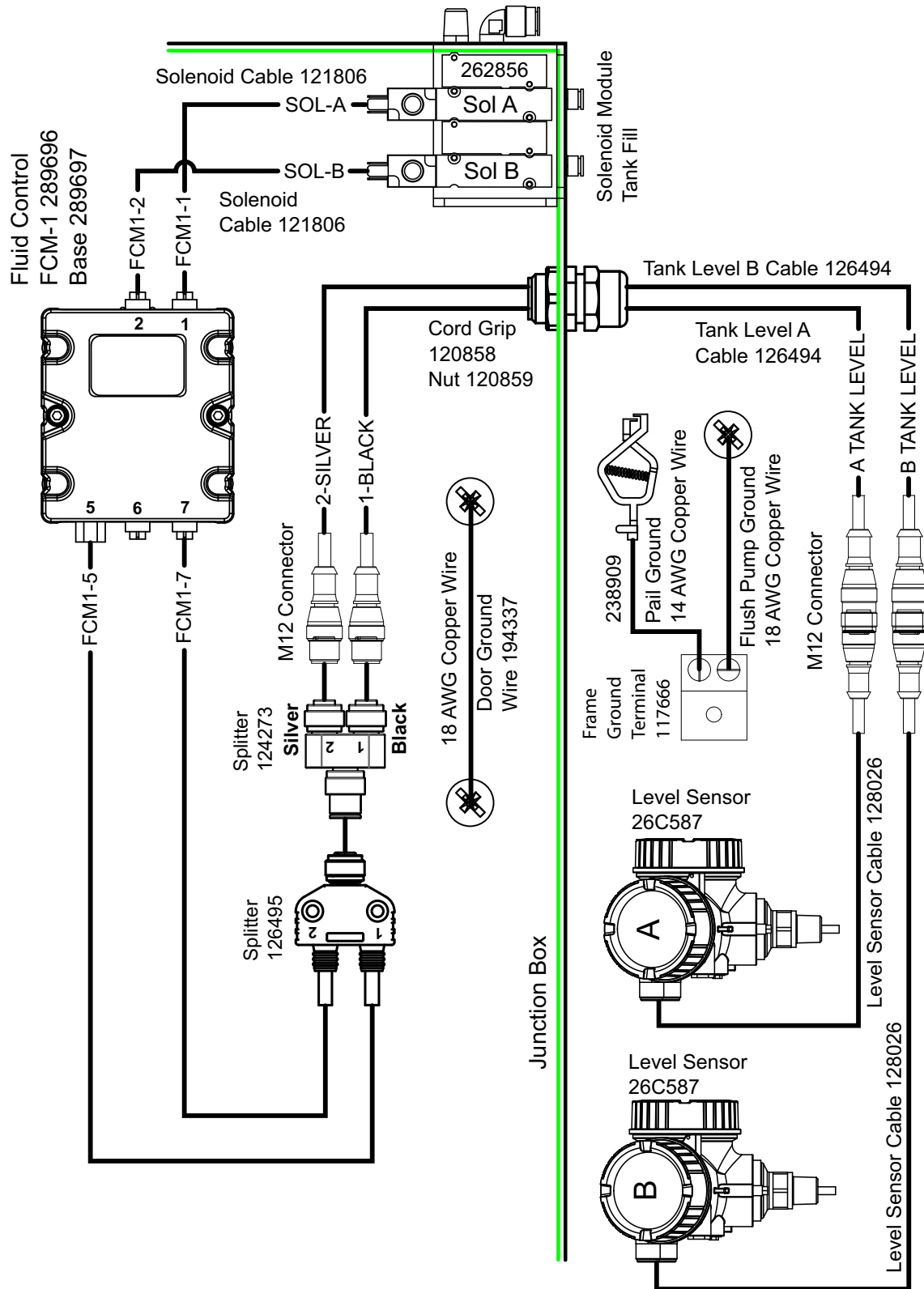

Sensors Schematic Control Box

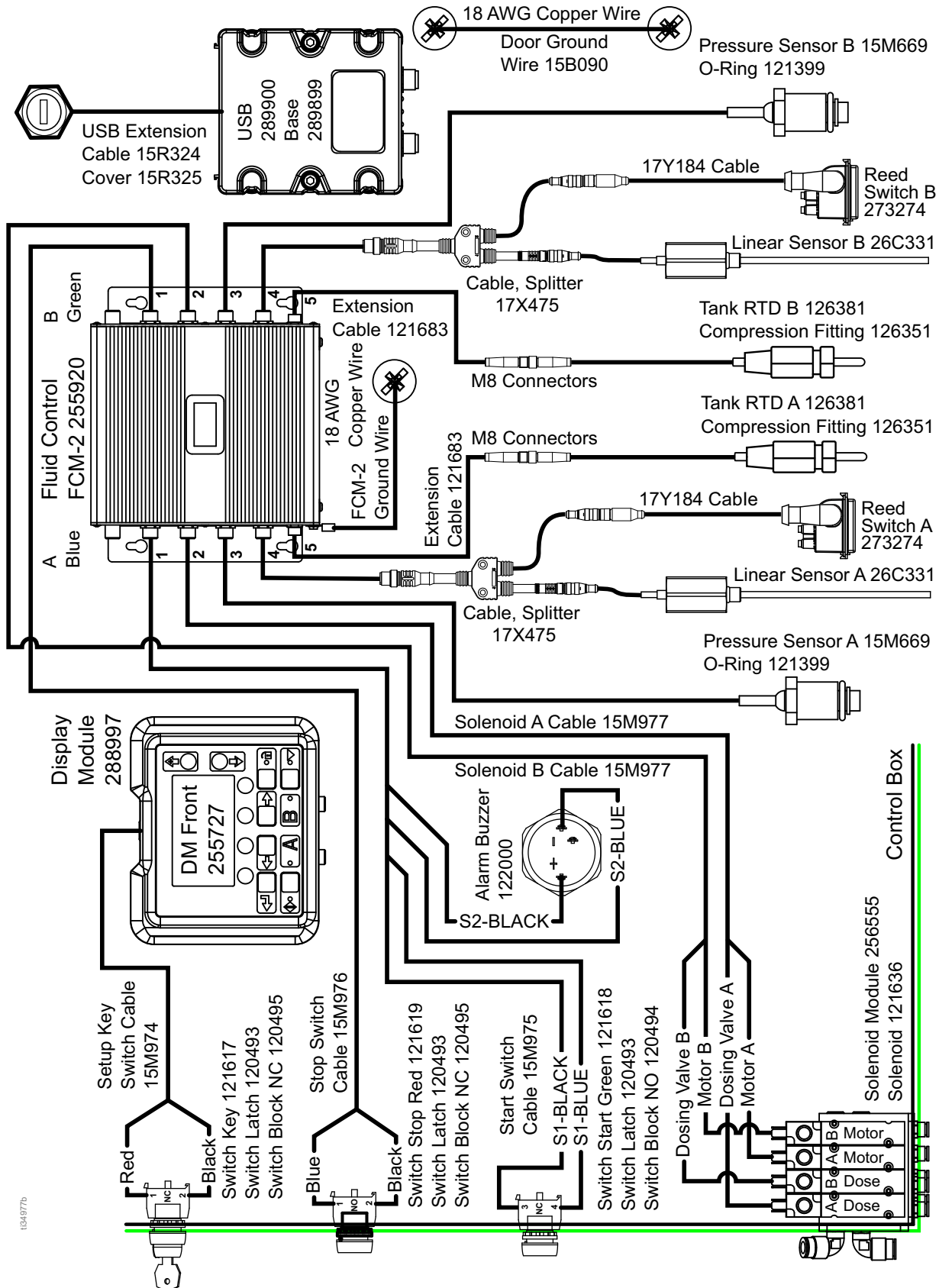

# Non-Hazardous XM PFP Air Logic Schematic

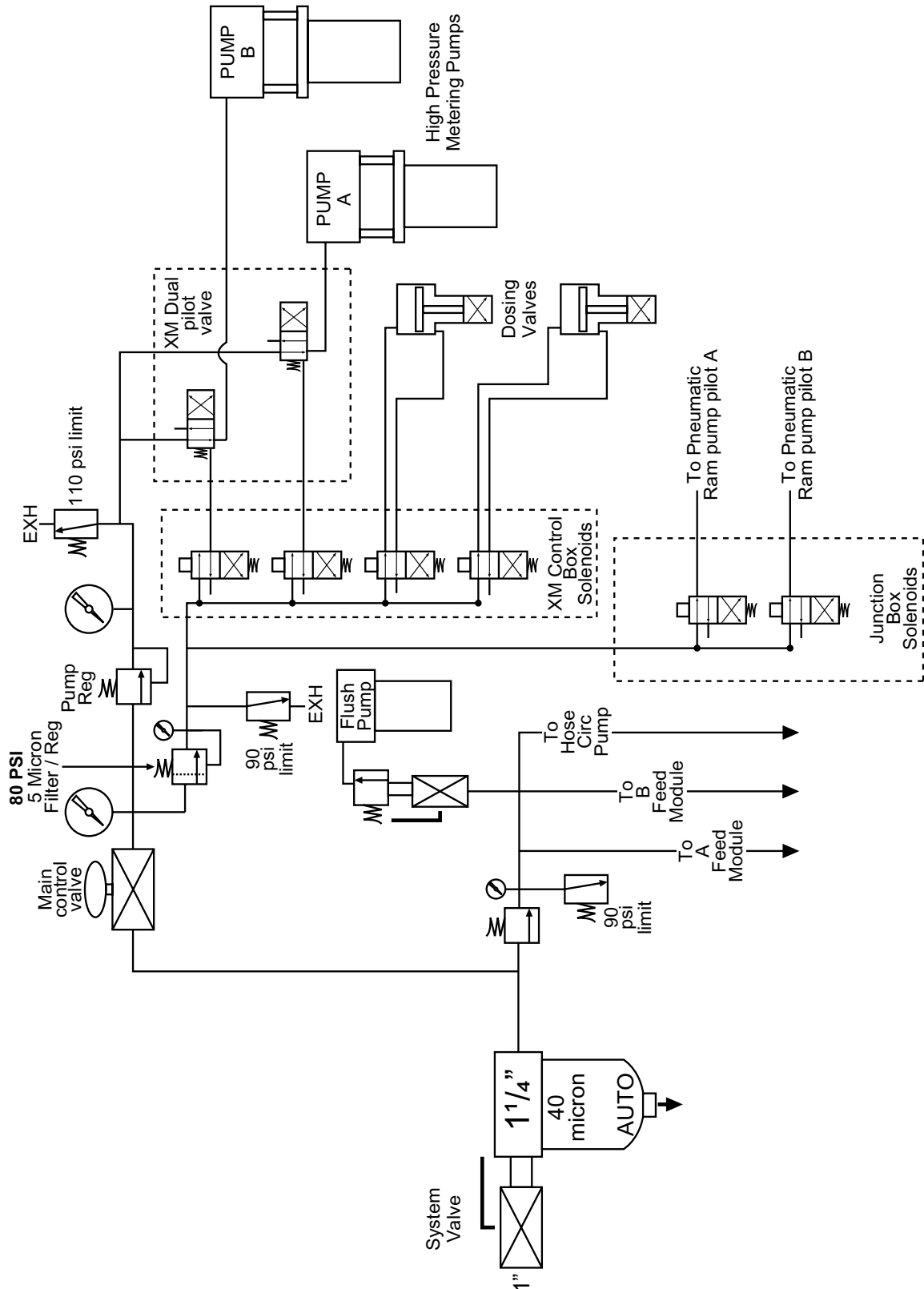

# Feed Module Air Controls Schematic

## Non-Hazardous Locations

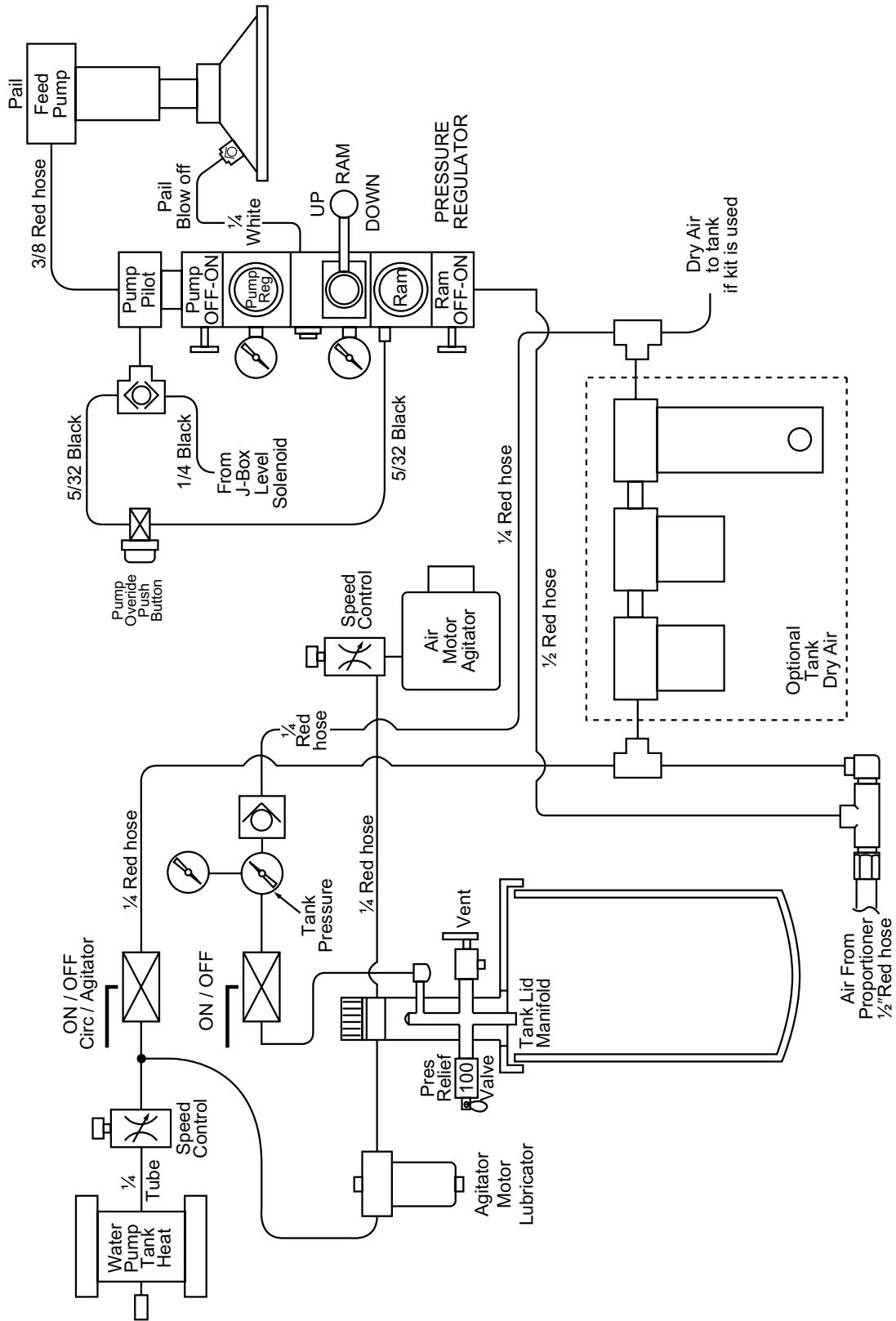

# Hazardous Location Schematics

## AC Power Schematic Explosion Proof Box

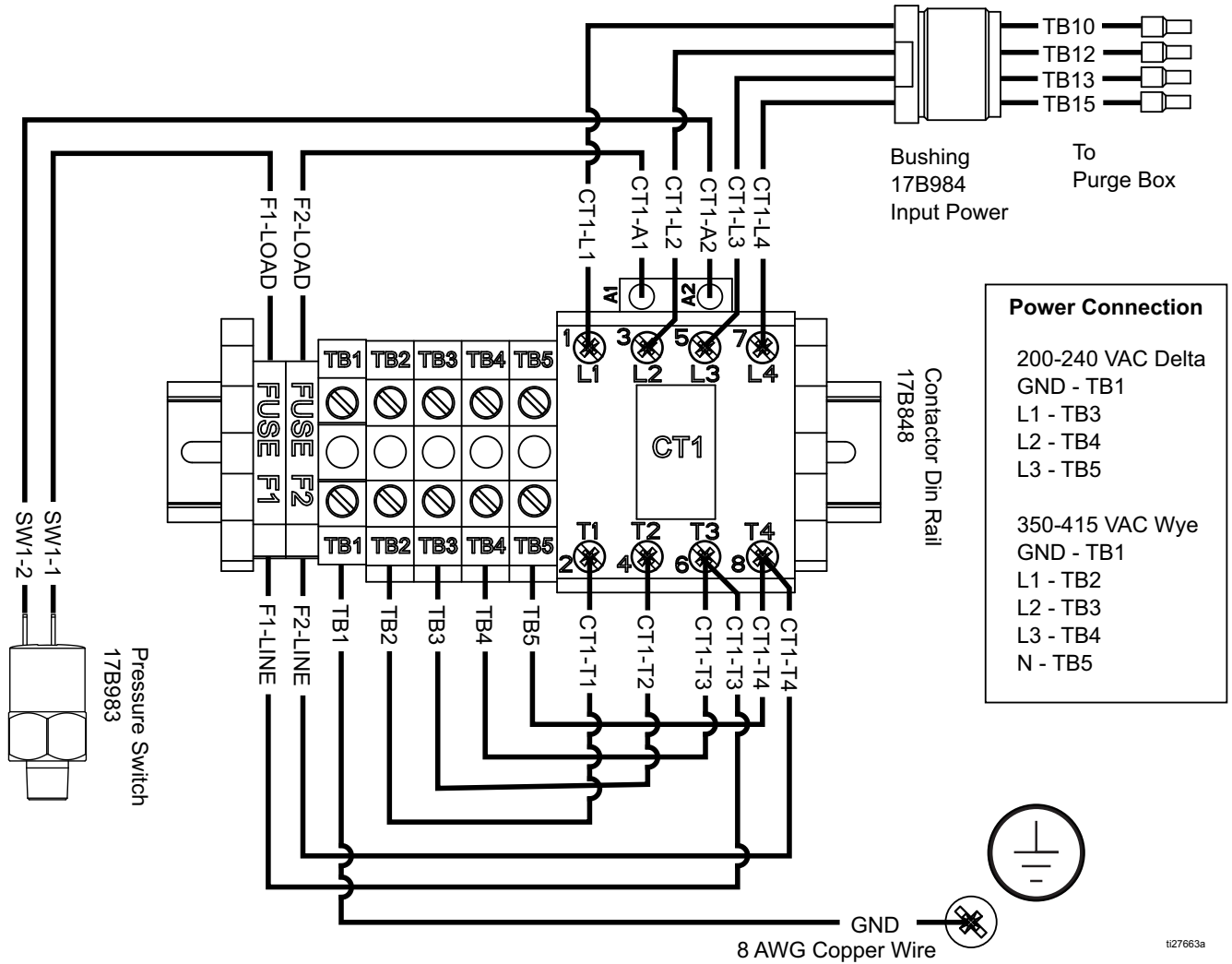



### Heater Schematic Purge Box

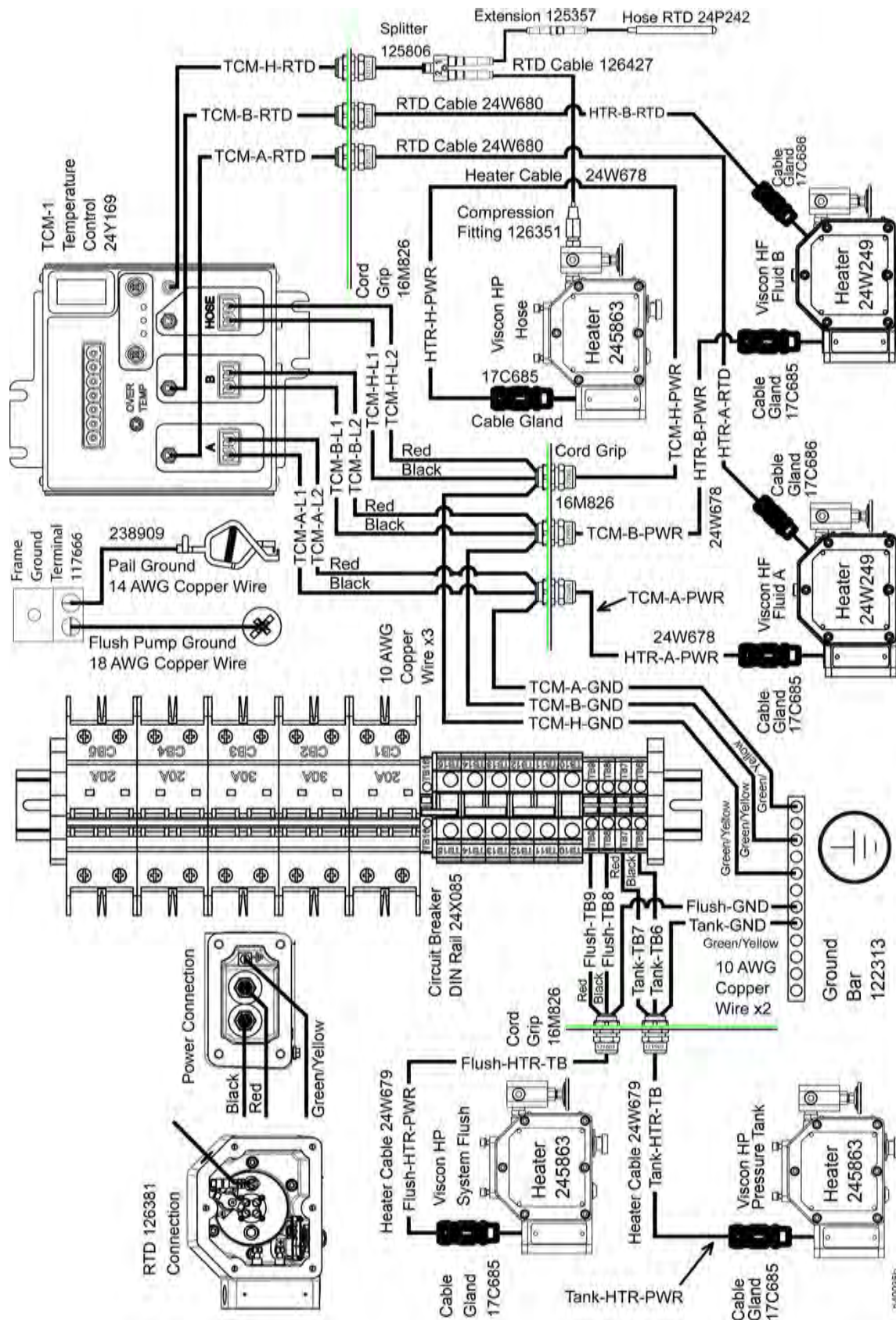

CAN Network and DC Power Schematic

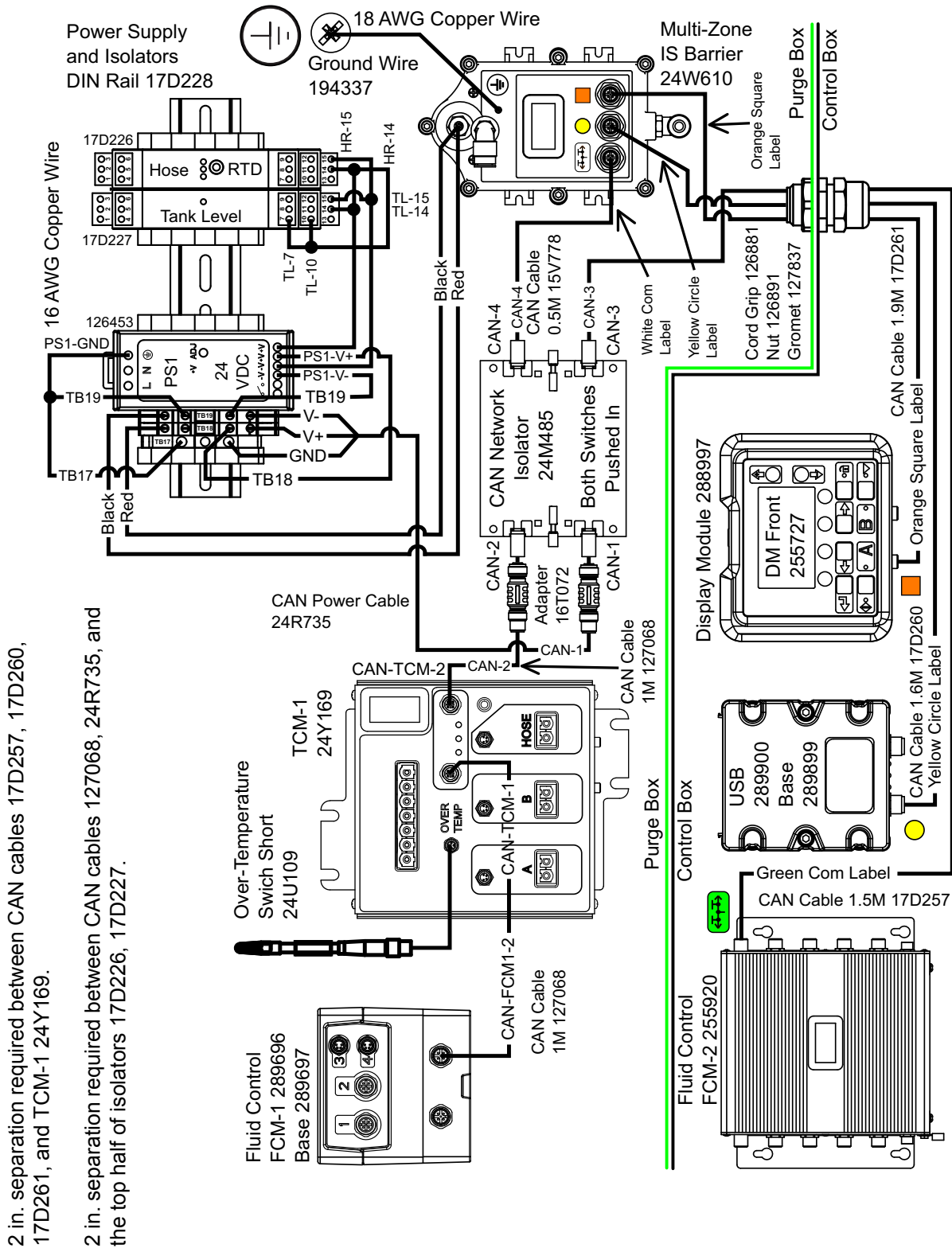

2 in. separation required between CAN cables 17D257, 17D260, 17D261, and TCM-1 24Y169.

2 in. separation required between CAN cables 127068, 24R735, and the top half of isolators 17D226, 17D227.

Sensors Schematic Purge Box

2 in. separation required between sensor cables 17D201, 17D202 and CAN network isolator 24M485 on previous page.

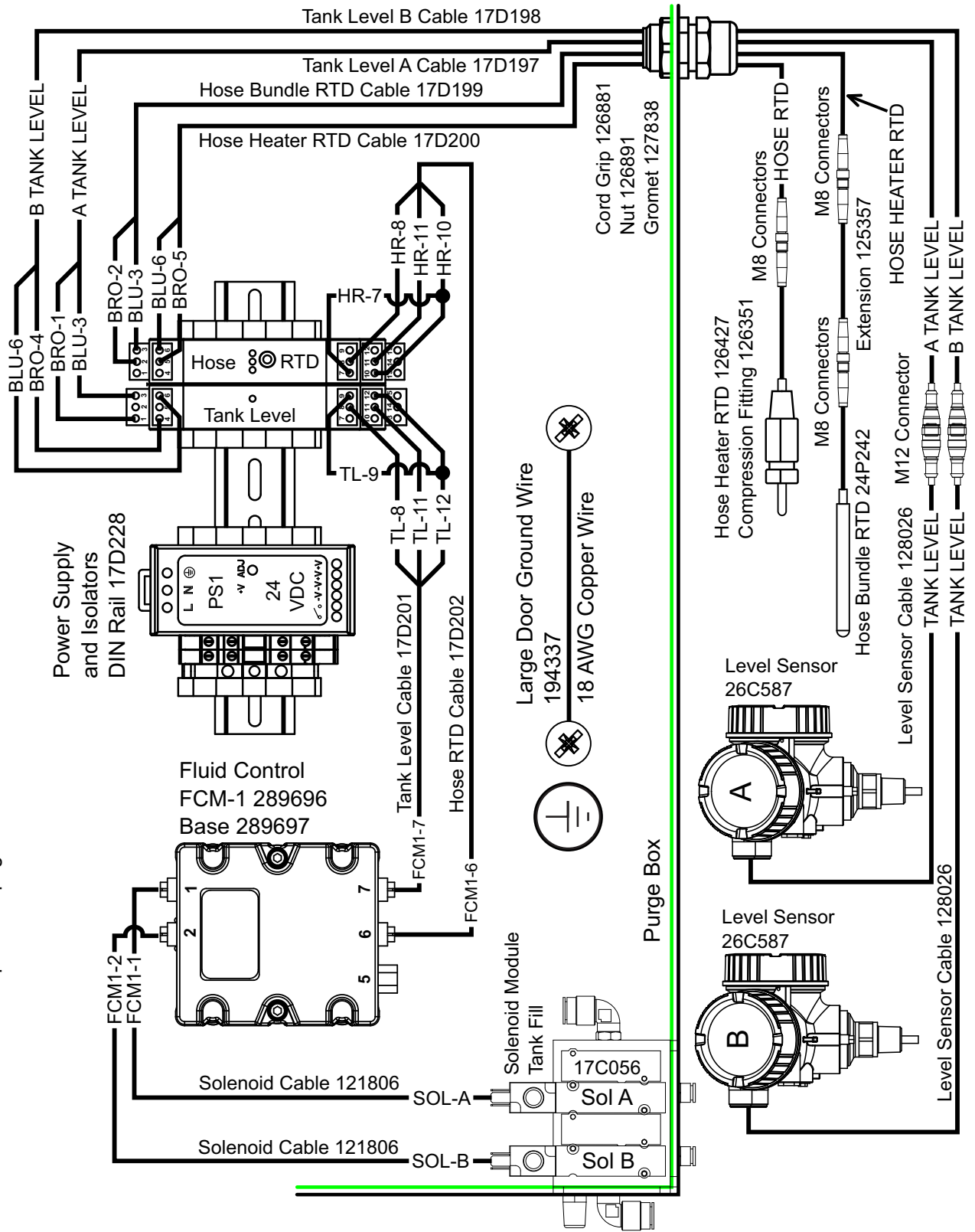

Sensors Schematic Control Box

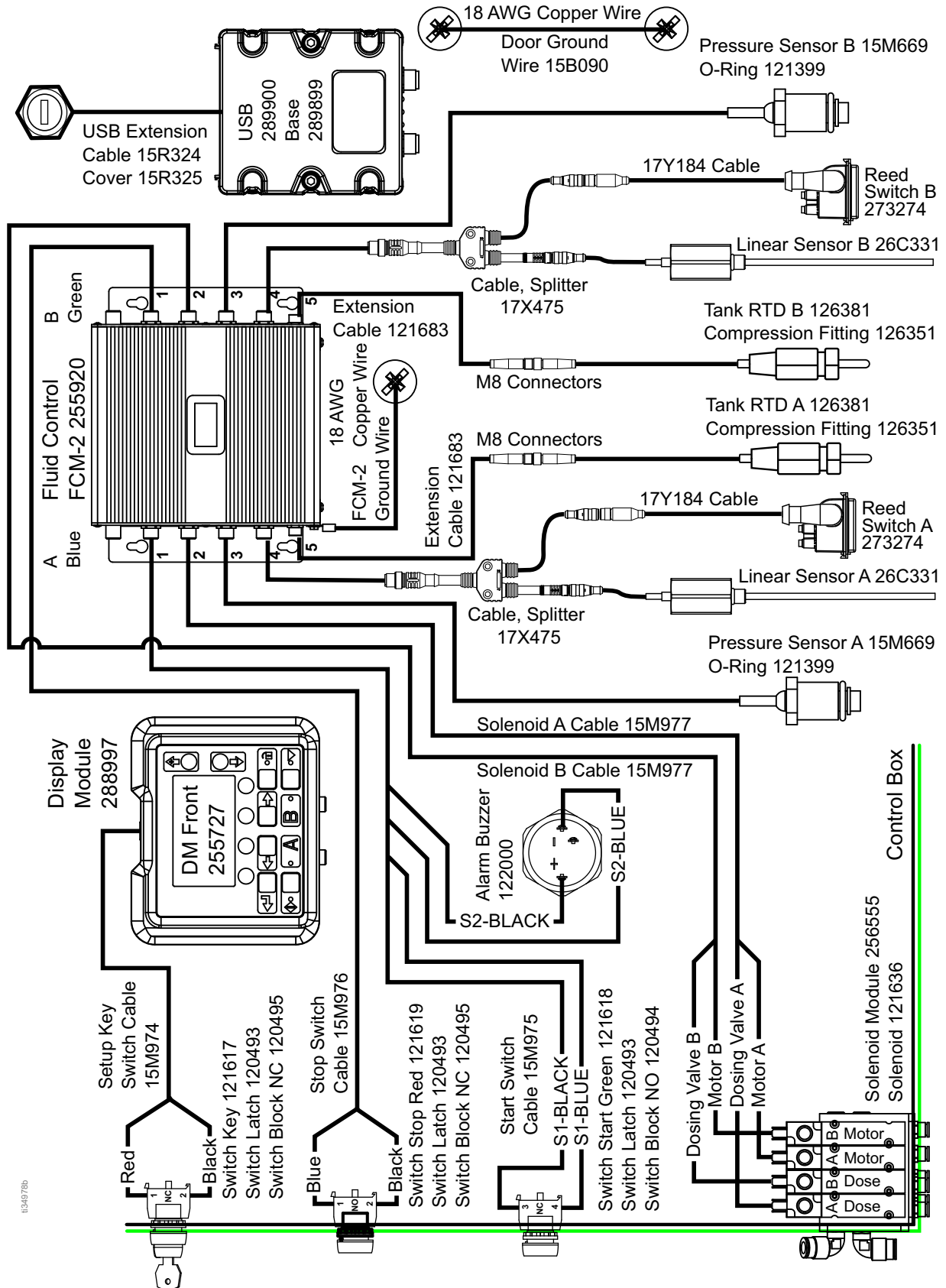

15349786

# Hazardous XM PFP Air Logic Schematic

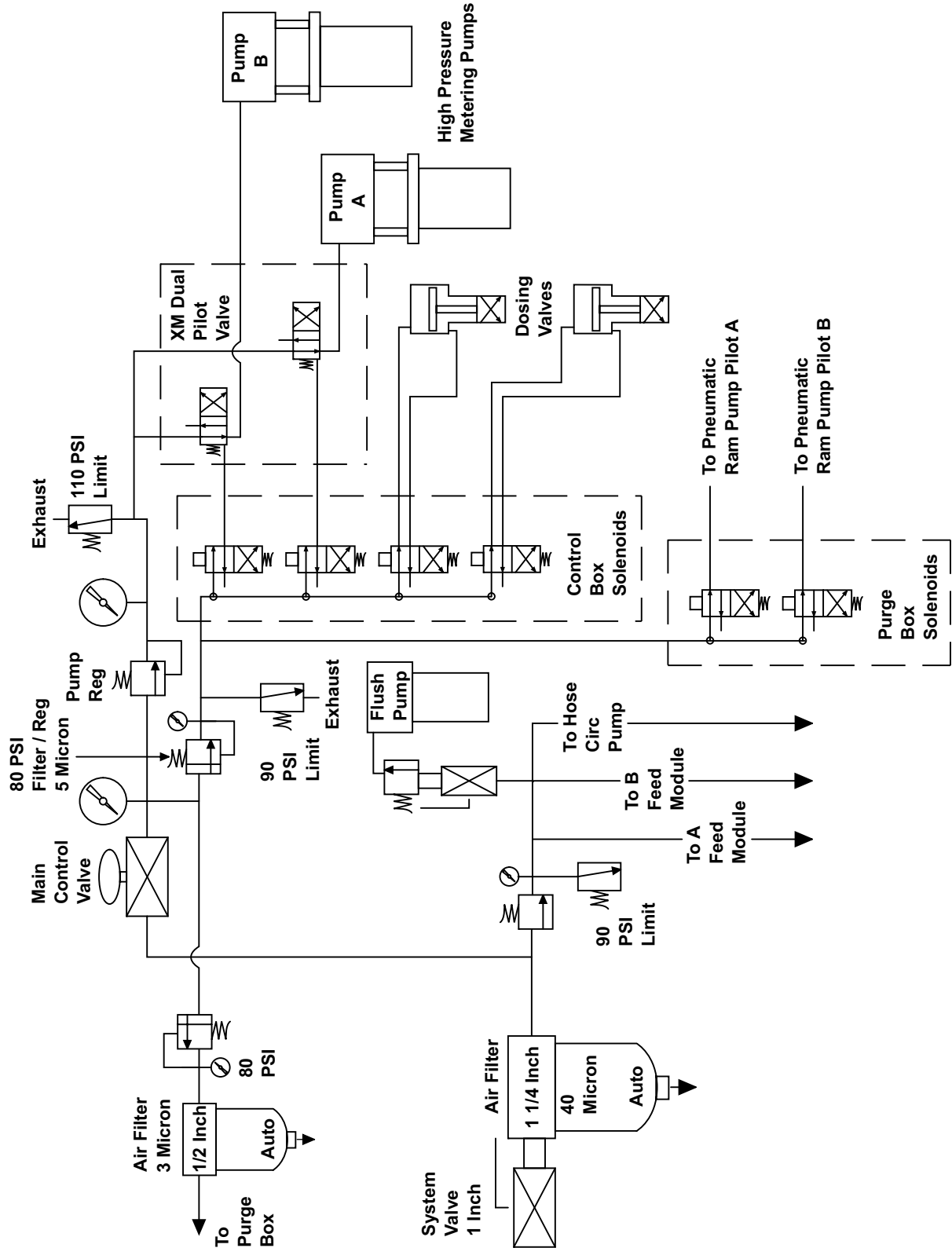

# Feed Module Air Controls Schematic

## Hazardous Locations

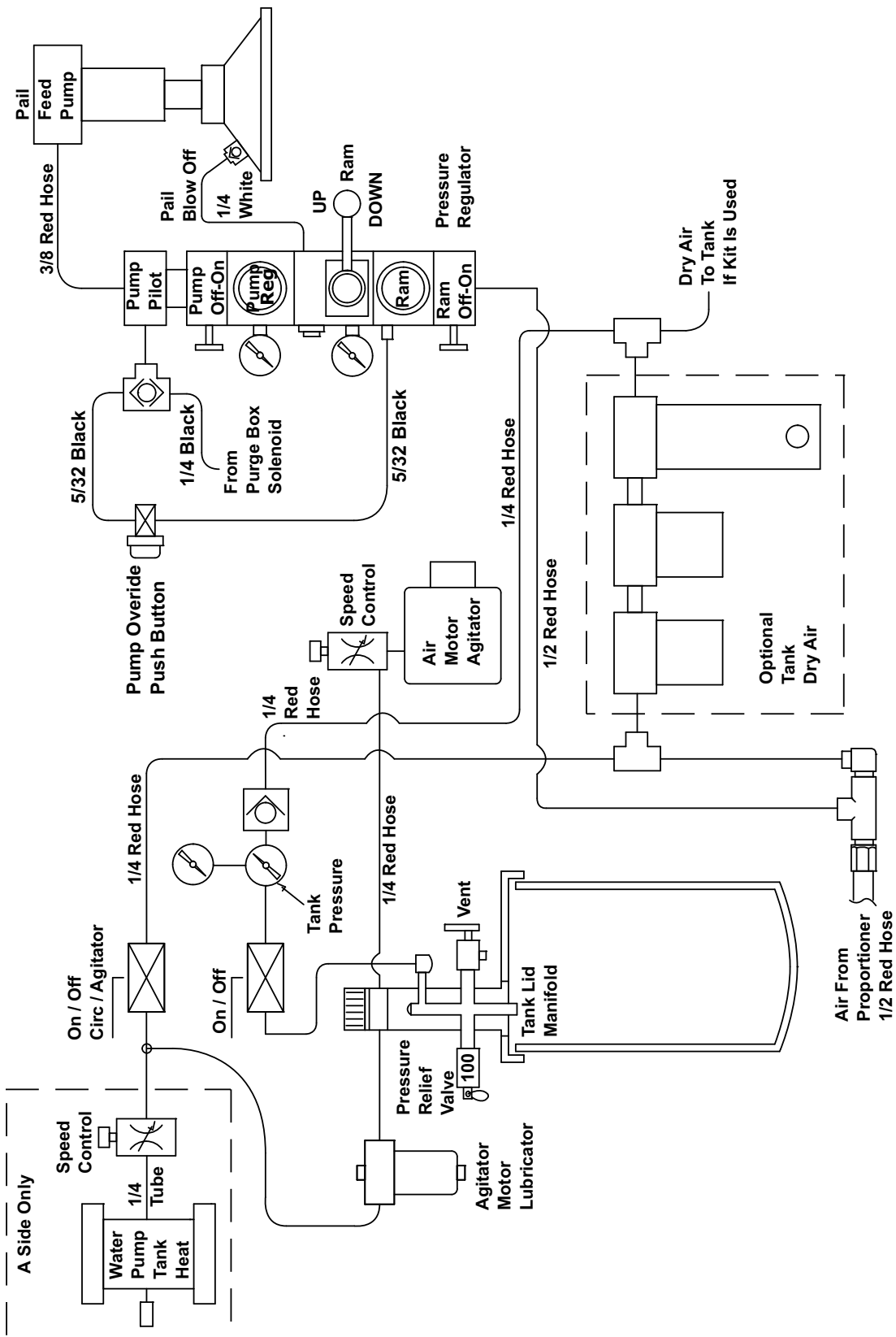

# Hazardous Location Purge Box Air Controls Schematic

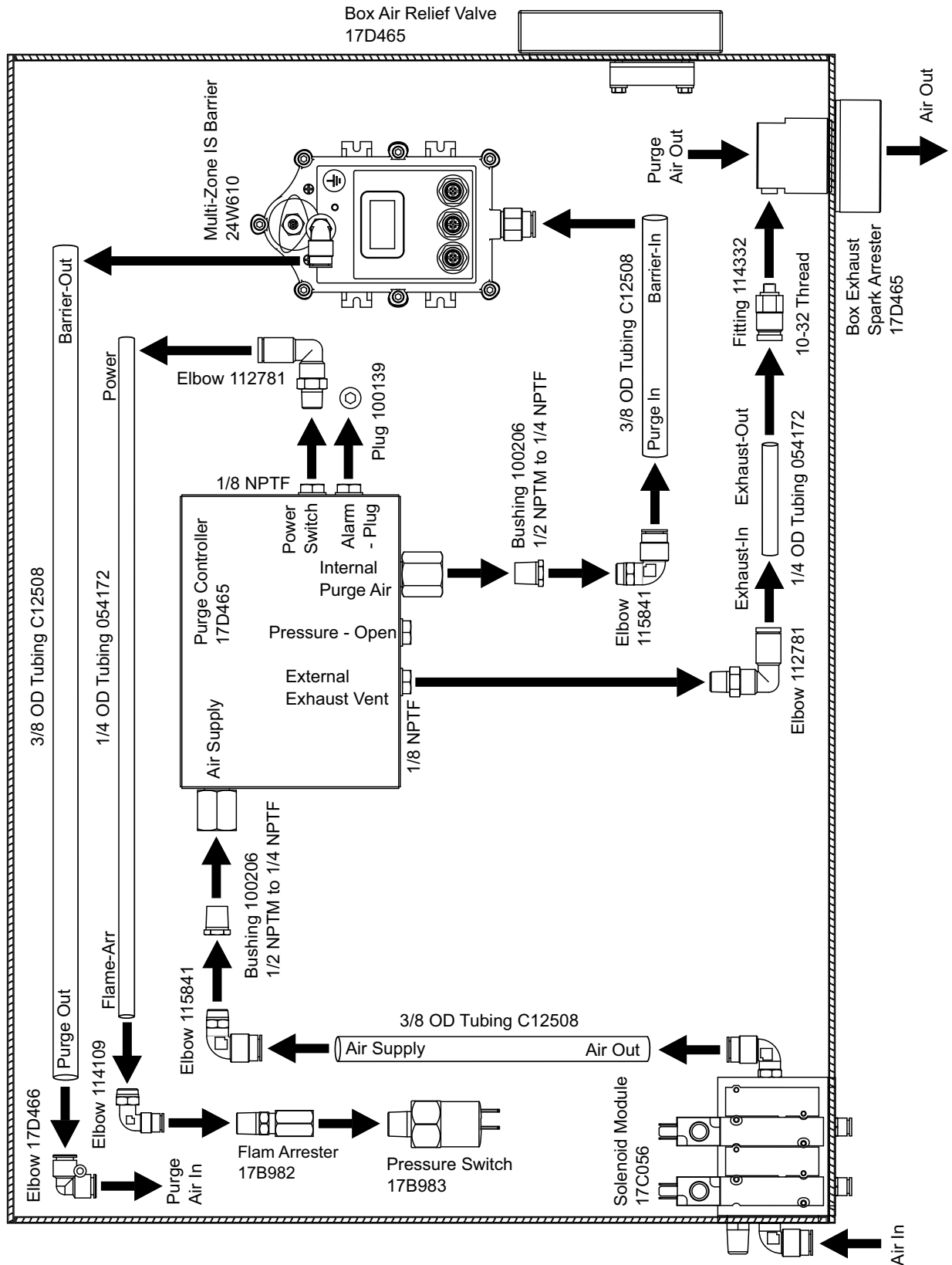

# Parts

System	Location	Ratio Range	Item and Quantity			
			(1) Base System	(2) Feed Skid	(3) Hose Bundle	Included Accessories
262869	Non-Hazardous	1.5:1 to 4:1	262878	24P202	16T121	
24W626		1:1 to 1.5:1			16T122	
262898	Non-Hazardous	1.5:1 to 4:1	262878	24P202	16T121	24P833 Mix Line and Gun Kit 262896 Air Dryer
262943	Hazardous	1.5:1 to 4:1	262941	24W987	16T121	24X113 Ex Hot Water Flush
262945		1:1 to 1.5:1			16T122	

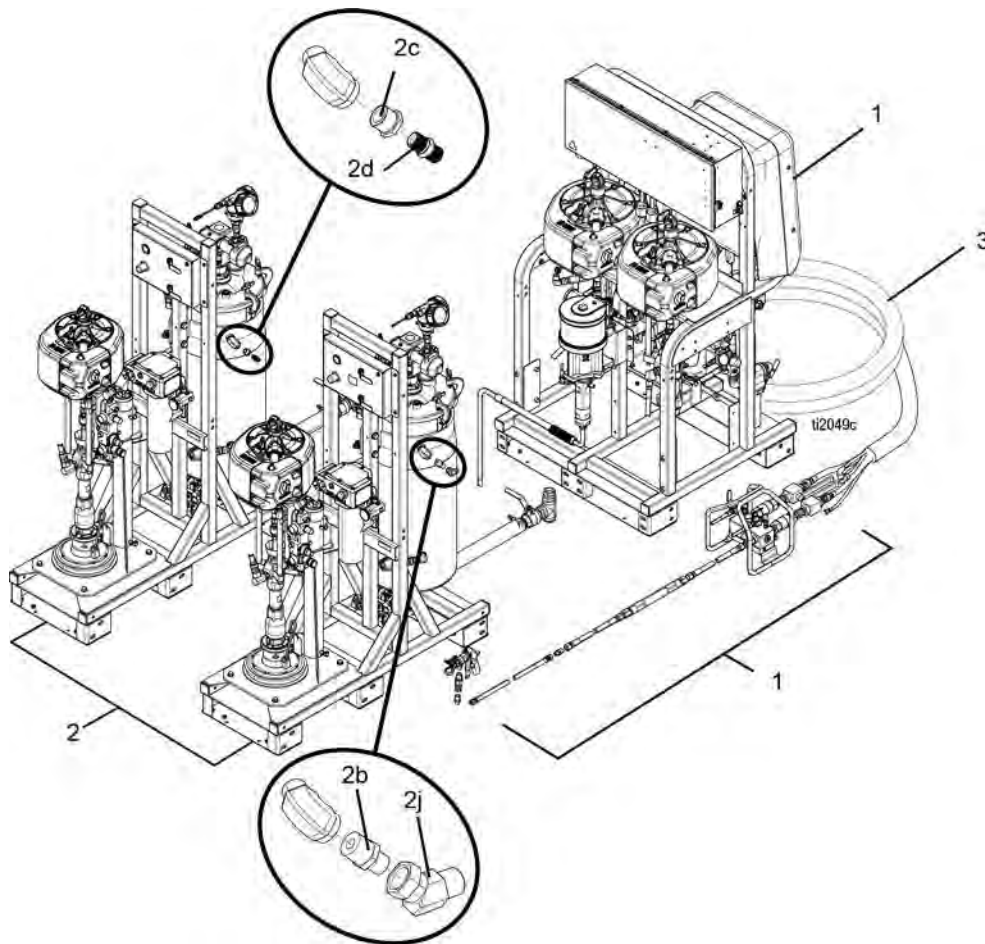

Ref.	Part	Description	Qty.
2b	C20461	NIPPLE, reducing	1
2c	100505	BUSHING	1
2d	156849	NIPPLE	1
2f	---	LABEL, A/B Identification (not shown)	1
2g	---	HOSE, nylon (not shown)	2.5
2h	---	CABLE TIE (not shown)	8
2j	222297	UNION, adapter	1

All machines are set up for 1/2 in. ID A and 3/8 in. ID B circulation return hoses. All machines come with kit 24X461 to convert to 1/2 in. A and 1/2 in. B return hoses for materials with very high viscosity B material.

--- Not for sale.

# XM PFP System Subassemblies

Non-Hazardous Location Base System (262878)  
Hazardous Location Base System (262941)

Page 1 of 5

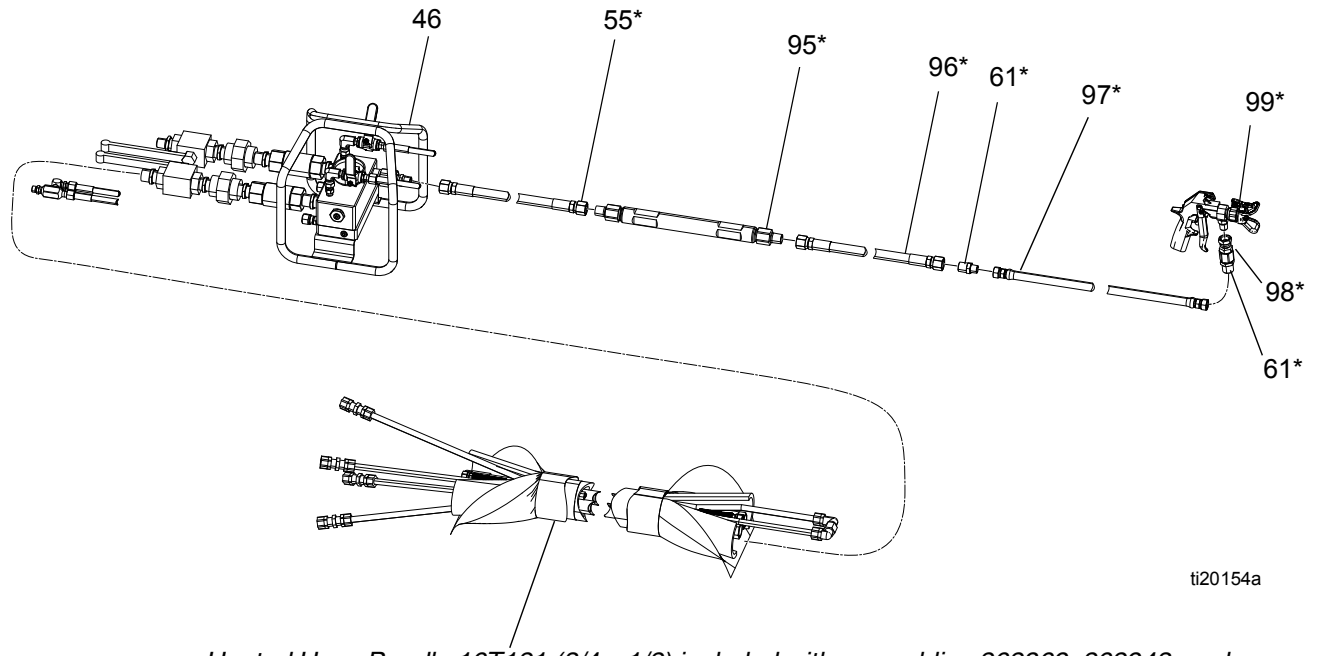

ti20154a

*Heated Hose Bundle 16T121 (3/4 x 1/2) included with assemblies 262869, 262943, and 262898.*

*Heated Hose Bundle 16T122 (3/4 x 3/4) included with assembly 262945 and 24W626.*

**NOTE:** Apply pipe sealant to all non-swiveling pipe threads.

*\* Parts Included in Mix Replacement Kit 24P833*

Base System (262878, 262941) page 2 of 5

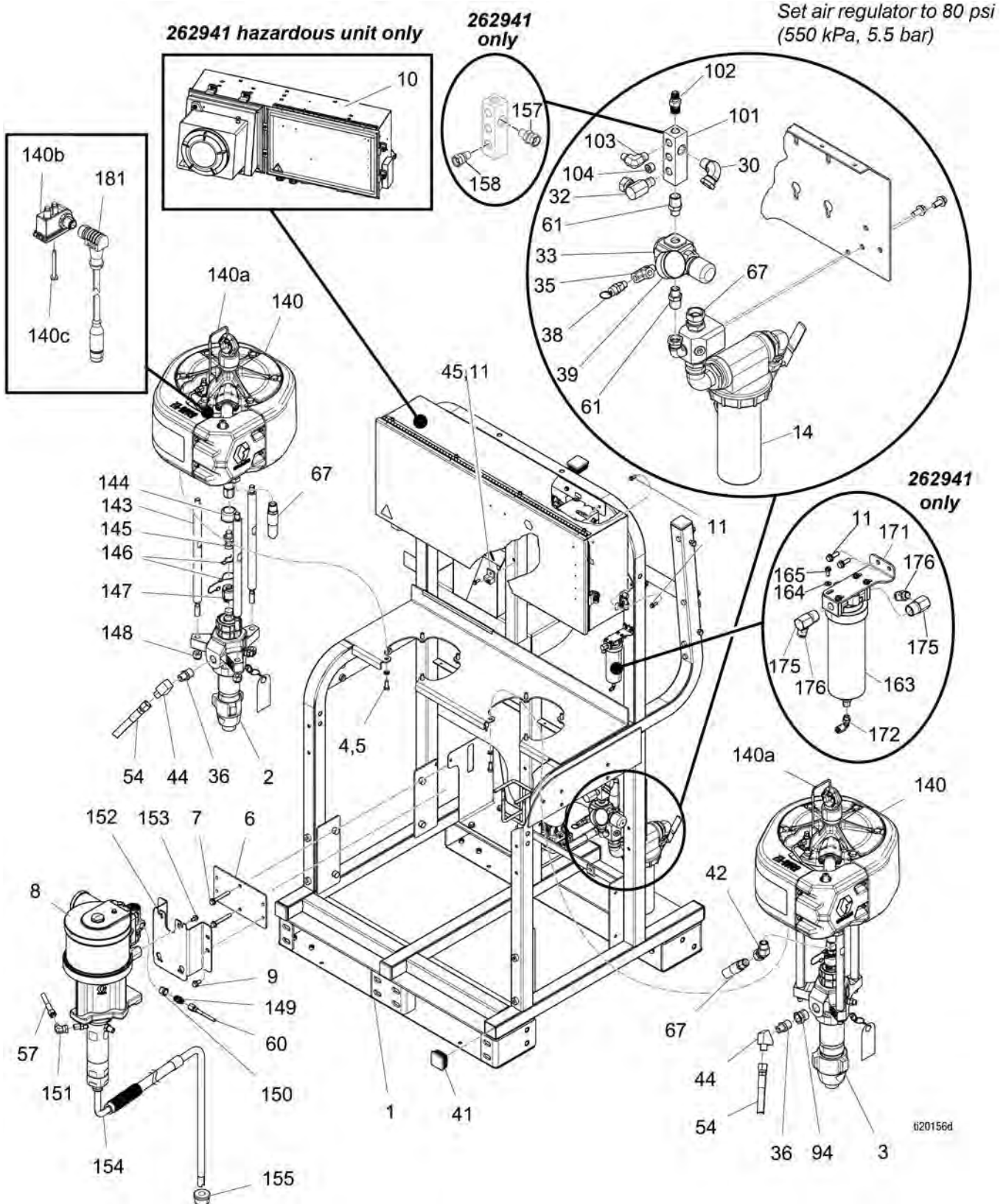

Base System (262878, 262941) page 3 of 5

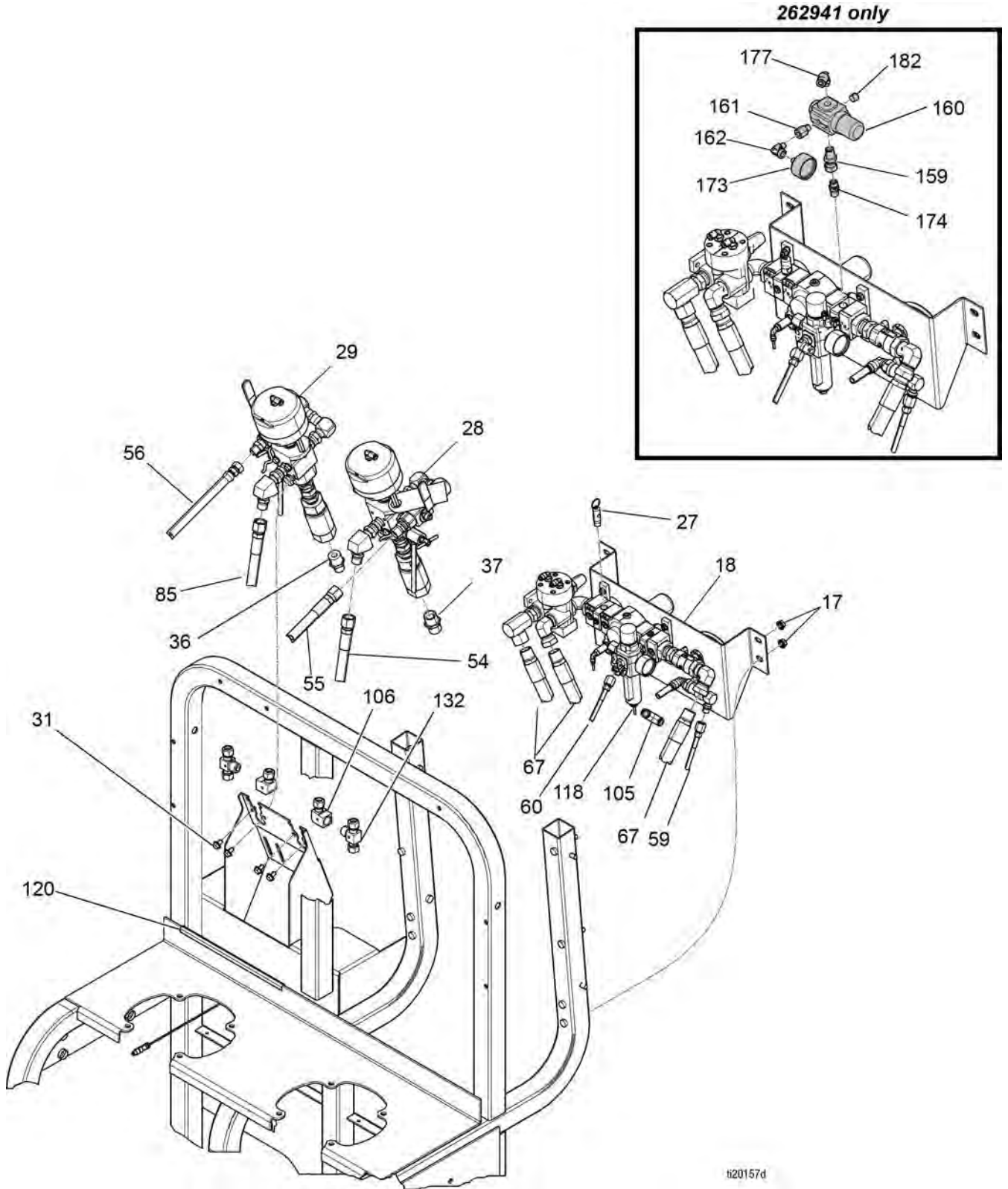

120157d

**NOTE:** Apply pipe sealant to all non-swiveling pipe threads.

Base System (262878, 262941) page 4 of 5

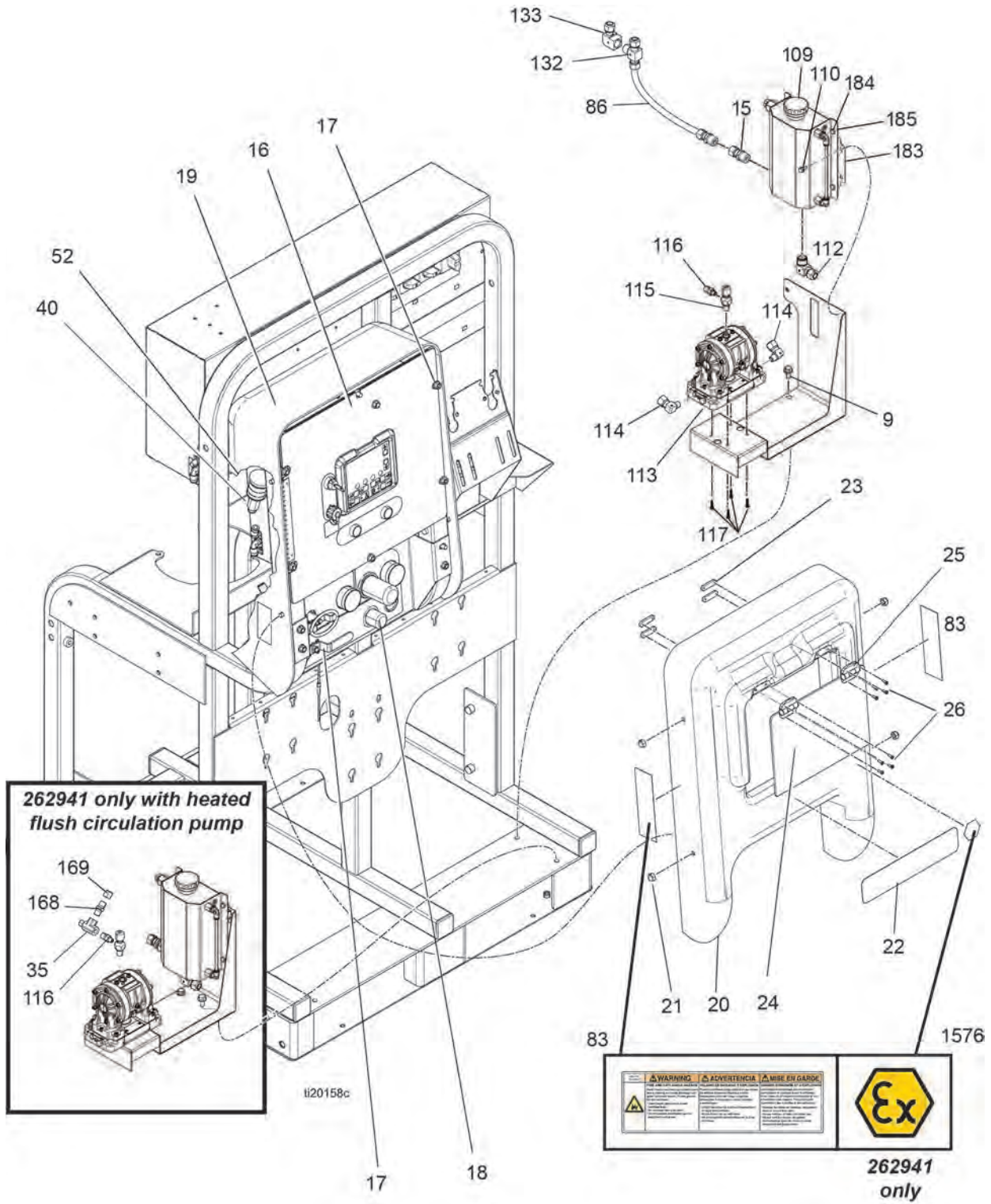

**NOTE:** Apply pipe sealant to all non-swiveling pipe threads.

Base System (262878, 262941) page 5 of 5

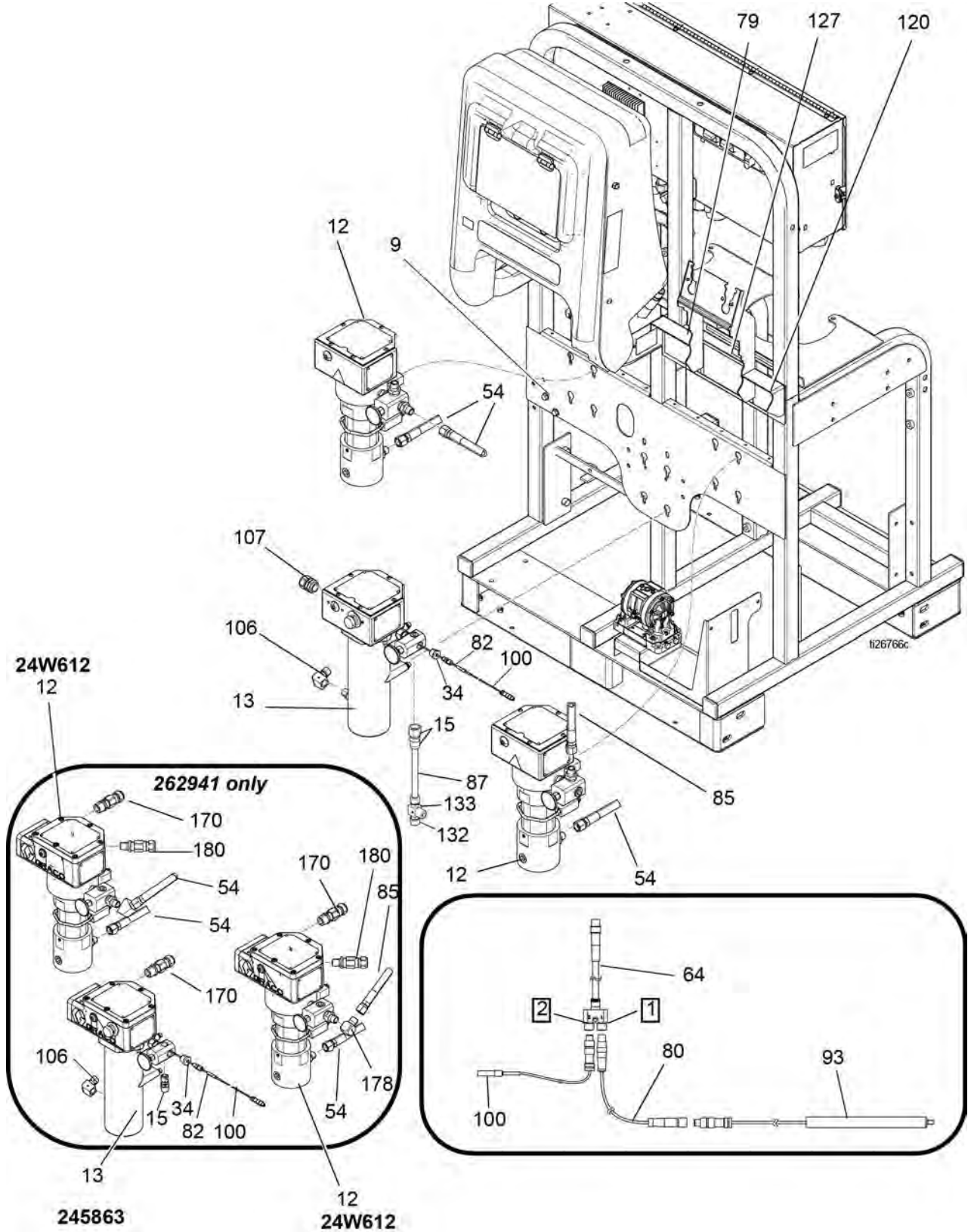

**NOTE:** Apply pipe sealant to all non-swiveling pipe threads.

**Base System (262878, 262941)**

Ref.	Part	Description	Qty.	Ref.	Part	Description	Qty.
						Model 262878	2
1	262875	FRAME	1	38	116643	VALVE, safety, relief, air	1
2	L180C9	PUMP; B side lower	1	39	101689	GAUGE, press, air	1
3	L220C9	PUMP; A side lower	1	40	121688	CONNECTOR, 3/8 npti x 3/8 tube	1
4	100133	WASHER, lock, 3/8	8			ptc	
5	100101	SCREW, cap, hex head	8	41	115313	PLUG, tube	8
6	256169	PLATE, flush pump	1	42	105281	3/4 npt, 45 degree	1
7	121488	SCREW, hex head, flanged	2	44	15M987	FITTING, elbow, 60 degree	2
8	W30CAS	PUMP, solvent, 6.0 in, 75 cc; see 312794	1	45	117666	TERMINAL, ground	1
				46	262893	MANIFOLD, mix; see manual	1
9	112395	SCREW, cap, flange head	8			3A2988	
10	24Y247	JUNCTION BOX; see page 73	1	47	---	SEALANT, pipe, stainless steel	1
	24W074	PURGE BOX, explosion proof; 262941 only, see page page 65	1	48	---	LUBRICANT, thread	1
				49	---	SEALANT, anaerobic	1
11	113796	SCREW, flanged, hex head <i>Model 262878</i>	6	50	206995	FLUID, TSL, 1 qt.	1
		<i>Model 262941</i>	10	52	108636	MUFFLER	1
12	262853	HEATER, Viscon HF	2	53▲	15X393	LABEL, warning, USB, all languages	1
	24W612	HEATER, Viscon HF; 262941 only	2	54	H75003	HOSE, coupled, 7250 psi, 0.50 in. ID, 3 ft	3
13	245869	HEATER, Viscon HP	1				
	245863	HEATER, Viscon HP; 262941 only	1	55‡	H75004	HOSE, coupled, 7250 psi, 0.50 in. ID, 4 ft	
14	24P899	FILTER, air, 1-1/4, assembly, page 78	1			Model 262878	3
						Model 262941	3
15	126899	FITTING, compression, straight	2	56	H73806	HOSE, coupled, 7250 psi, 0.375 in. ID, 6 ft	1
16	255771	BOX, control, air/electric, page 76	1				
17	112958	NUT, hex, flanged	10	57	H42506	HOSE, coupled, 4500 psi, 0.25 in. ID, 6 ft	1
18	255761	MODULE, air controls, upper, page 64	1				
19	16P815	COVER, shroud, rear	1	58	205418	HOSE, coupled, air, 1/2 x 6 ft	2
20	256177	COVER, shroud, front	1	59	16P244	HOSE, coupled, air, 5/16 x 3 ft	2
21	117623	NUT, cap, 3/8-16	4	60	248208	HOSE, coupled, air, 5/16 x 4 ft	1
22	16T209	LABEL, XM PFP	1	61‡	159239	FITTING, nipple, pipe, reducing	4
23	15T567	NUT, backup plate, hinge	4	62	17L724	FLASH DRIVE, USB, 2.0	1
24	15T568	DOOR, control shroud	1	63	121456	CONNECTOR, power, male, 3 pin	1
25	121471	HINGE, friction, positioning	2	64	125806	CABLE, splitter, M8, 4-pin, female/female/male, 1.5 m	1
26	112380	SCREW, mach, pan head	8				
27	113498	VALVE, safety, 110 psi	1	66	16T123	CABLE, GCA, CAN, male/female, 1.0 m (not shown)	1
28	262887	VALVE, ratio control, left; page 79	1	67	240900	HOSE, coupled, air, 30 in. x 3/4 in.	3
29	262888	VALVE, ratio control, right; page 79	1	68	054172	TUBE, nylon, round, black, 1/4 in.	26.5
				69	054175	TUBE, nylon, round, natural, 1/4 in.	8.5
30	C19024	FITTING, elbow, swivel	1				
31	111801	SCREW, cap, hex head	8	70	551390	SIGHTGLASS, beaker, graduated (not shown)	10
32	217430	FITTING, swivel, union, 90 degree	1				
33	15T536	REGULATOR, air, 3/8 npt	1	71	114958	STRAP, tie	20
34	100329	BUSHING, pipe	1	73	238909	WIRE, grounding assembly	1
35	116504	FITTING, tee, run <i>Model 262878</i>	1	74	C12508	TUBING, nylon, round, black, 3/8 in.	4.7
		<i>Model 262941</i>	2				
36	C20461	FITTING, nipple, reducing, hex Model 262878	3	76	109025	TERMINAL, ring	1
				79	16P856	LABEL, codes, alerts; all languages	1
37	160032	FITTING, nipple					

Ref.	Part	Description	Qty.	Ref.	Part	Description	Qty.
80	125357	CABLE, M8, 4-pin, male/female, 1 meter	1	122	100679	SCREW, cap, hex head	8
82	126351	FITTING, compression, thermocouple	1	123	115211	SCREW, cap, hex head	2
83▲	15T468	LABEL, warning	2	124	---	SCREW, hex head with serrated face flange base, 1/2-13	8
85	H75002	HOSE, coupled, 7250 psi, 0.5 in. (12 mm) ID, 2 ft	1	125	109570	WASHER, plain	20
86	054961	TUBE, 0.375 in. (9.5 mm) ID blue nylon	6	126	112731	NUT, hex, flanged	10
87	054960	TUBE, 0.375 in. (12 mm) ID red nylon	1.5	127▲	15W598	LABEL, warning	1
88	114601	CONDUIT, flexible, non-metallic	3.5	128	15U654	LABEL, identification, A/B	1
92	15T258	TOOL, wrench, Xtreme, 145/290 (not shown)	1	129	---	FLUID, ethylene glycol/water	2
93	24P242	SENSOR, RTD, 1k ohm, insulated	1	131	16F366	FITTING, 1/4 in. x 1/4 in. push to connect	2
94	158586	FITTING, bushing	1	132	126895	FITTING, tee, tube x tube x nptm	2
95‡	16T316	MIXER, static, assembly, page 83	1	135	121683	CABLE, M8, 4-pin, male/female, 3 meter	2
96‡	H75010	HOSE, coupled, 7250 psi, 0.50 ID, 10 ft	1	136	122032	NUT, wire	2
97‡	H73803	HOSE, coupled, 7250 psi, 0.375 ID, 3 ft	1	137	15V778	CABLE, CAN, female-female, 20 in.	1
98‡	24P834	SWIVEL, straight	1	138	15V779	CABLE, CAN, female-female, 34 in.	1
99‡	262854	GUN, spray	1	140	XL65D2	MOTOR, 6500 with sensor	2
100	126427	SENSOR, RTD, 1K ohm, 4 pin, 8 in.	1	140a	26C331	LINEAR SENSOR ASSEMBLY	
101	158990	MANIFOLD, air	1	140b	273274	REED, switch	
102	165198	FITTING, nipple, reducing	1	141	100133	WASHER, lock	8
103	121858	FITTING, elbow, 3/8 npte x 1/4 npte	1	142	100101	SCREW	8
104	101754	PLUG, pipe	1	143	257150	ROD, tie	6
105	119798	CONNECTOR, tee, push-tube	1	144	197340	COVER, coupler	2
106	126896	FITTING, elbow, tube	3	145	15H392	ROD, adapter	2
107	121603	GRIP, cord, 0.51-0.71, 3/4	1	146	244820	CLIP, hairpin lanyard	2
108	16T745	BRACKET, water circulation, mount	1	147	244819	COUPLING, assembly rod	2
109	2002997	TANK, overflow, 2L, aluminum	1	148	101712	NUT, nyloc	6
110	113161	SCREW, flange, hex head	2	149	157350	ADAPTER, 3/8 x 1/4	1
112	126898	FITTING, elbow	1	150	100081	BUSHING	1
113	24P835	PUMP, diaphragm, 205	1	151	116395	UNION, 90 degree, 1/4 male x 3/8 swivel	1
114	126897	FITTING, elbow	2	152	256561	PLATE, mount, pump	1
115	206264	VALVE, needle	1	153	111799	SCREW, M8 x 1.25 x 16 mm	4
116	151519	FITTING, nipple, reducing; Model 262878 and 24W648	1	154	24W662	HOSE, siphon	1
	16D939	FITTING, nipple, reducing; Model 262941	1	155	181073	STRAINER, inlet	1
117	15R472	FASTENER, hex head, flanged, 1/4 x 1	4	157‡	190451	UNION, adapter	1
118	054760	TUBE, polyurethane, round, black	5	158‡	162505	FITTING, union, swivel	1
119	100028	WASHER, lock	1	159‡	156823	FITTING, union, swivel	1
120	115901	TRIM, edge, protection	2	160‡	116513	REGULATOR, air	1
121	16T171	STRAP, frame connector	2	161‡	16T421	ADAPTER, pipe hex	1
				162‡	112307	FITTING, street elbow	1
				163‡	234402	KIT, filter, air	1
				163a	24V097	KIT, repair, desiccant air (not shown)	1
				164‡	102360	WASHER, flat	4
				165‡	---	SCREW, mach, slot hex washer hd, 10-24 x 1/2 in.	4
				166‡	24P834	SWIVEL, straight, PTFE	1

## Parts

Ref.	Part	Description	Qty.
167	† ---	NIPPLE, 3/8 - 1/4 npt x 2.6 in.	1
168	† 156971	FITTING, nipple short	1
169	† ---	FITTING, cap, hex, 1/4 npt(f)	1
170	† 24W678	CABLE, assembly, armored	3
171	† ---	BRACKET, air filter	1
172	† 112698	ELBOW, male, swivel	1
173	† 113911	GAUGE, pressure, air	1
174	† 162453	FITTING, 1/4 npsm x 1/4 npt	1
175	† 166999	FITTING, elbow, street, 1/2M x 1/4F	2
176	† 122161	FITTING, air	2
177	† 115841	FITTING, elbow	1
178	† 158683	FITTING, elbow, 90°	1
179	† 17D946	LABEL, cord wrap (not shown)	1
180	† 24W680	CABLE, assembly, armored	2
181	† 17Y184	CABLE, GCA, M12-5P	2
182	† 100721	PLUG, pipe	1
183	† 2003028	BRACKET, adapter, tank, painted	2
184	† 100157	SCREW, cap, hex hd	4
185	† 102040	NUT, lock, hex	4

--- *Not for sale.*

▲ *Replacement safety labels, tags and cards are available at no cost.*

† *262941 only.*

‡ *Included in mix line and gun kit 24P833.*

### 24X461 1:1 Fitting Kit

Use to convert the B side recirculation parts on 262941 for 1:1 ratio materials. See manual 334939 for detailed instructions.

# Feed Modules

Page 1 of 2

**B Side Feed Module, 24Y098**  
**A Side Feed Module, hazardous**  
**area unit, see items 226 and 325**  
**A Side Feed Module, 24Y097**

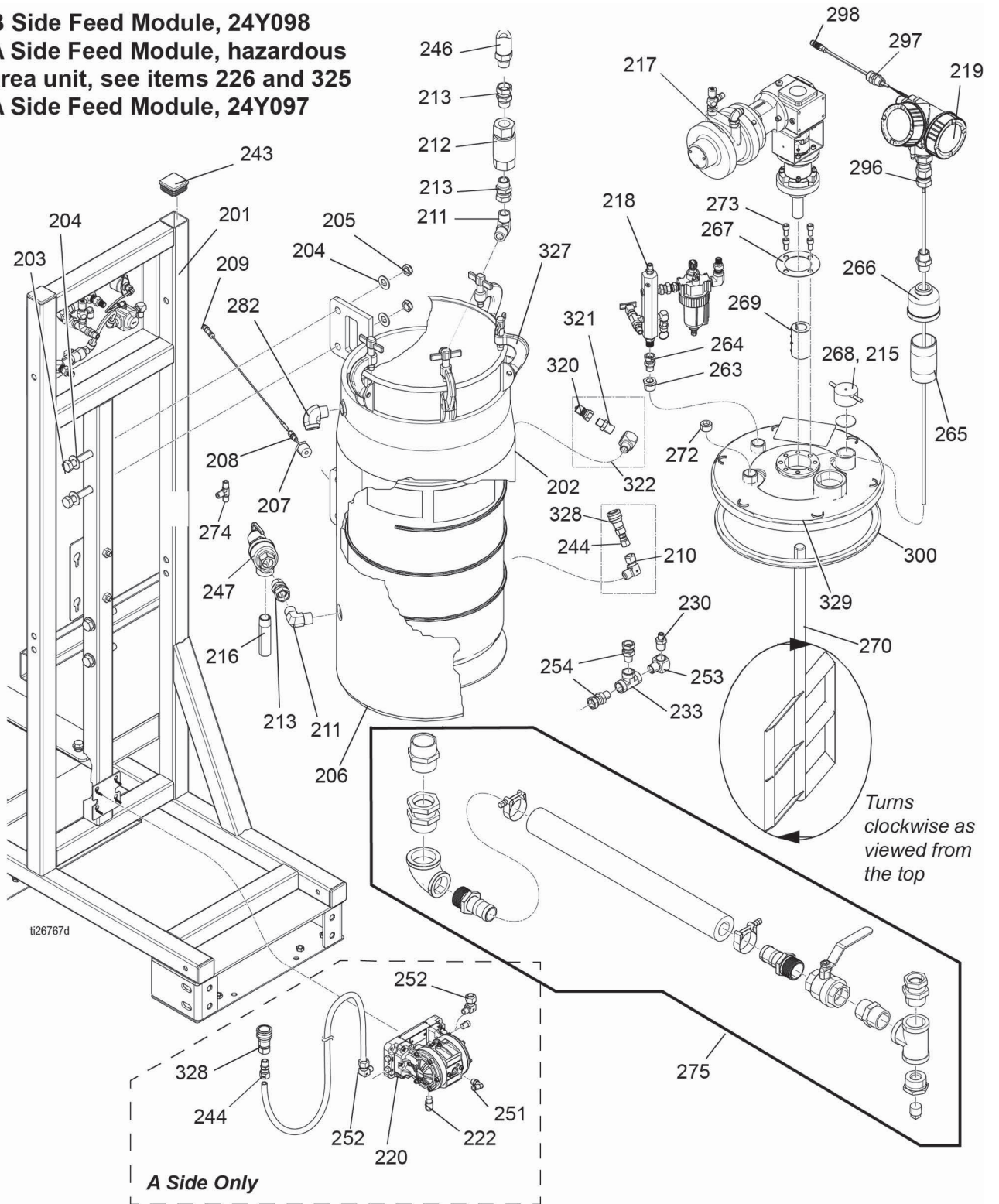

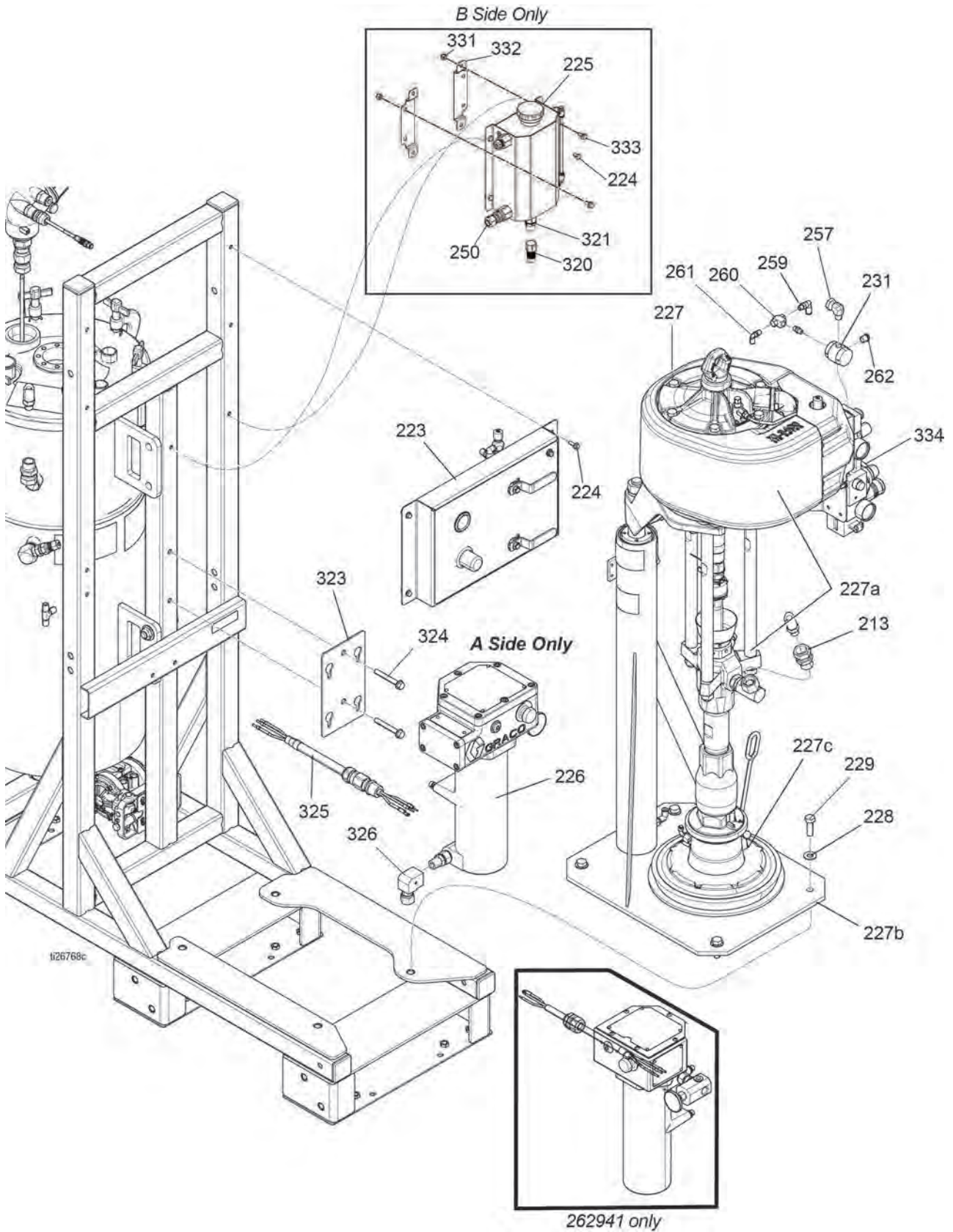

## Feed Modules Continued

Ref.	Part	Description	Qty.	Ref.	Part	Description	Qty.	
201	262841	FRAME	1	227c	16U676	PLATEN, pail, see 3A3113	1	
202	24M683	TANK, pressure, assembly	1	228	GC2041	WASHER, flat, std, 1/2	4	
203	---	BOLT, hex head, 3.25 in. long, 5/8-11	4	229	100017	SCREW, cap, hex head	4	
204	111841	WASHER, plain 5/8	8	230	162449	FITTING, nipple, reducing	4	
205	---	NUT, self-locking hex, nylon insert, 5/8-11	4	231	104633	VALVE, pilot	1	
206	16R869	COVER, tank wrap	1	232	---	SEALANT, pipe, stainless steel	1	
207	120870	BUSHING, pipe, hex head, 3/4 npt x 1/8 npt, steel	1	233	103475	FITTING, tee, pipe	1	
208	126351	FITTING, compression, thermocouple	1	234	054960	TUBE, 0.375 in. (9.5mm) ID red nylon	3.8	
209	126381	SENSOR, RTD, 1k ohm, 4 pin, 3 in.	1	235	054961	TUBE, 0.375 in. (9.5mm) ID blue nylon	4.2	
210	126898	FITTING, elbow	2	236	205418	HOSE, coupled	1	
211	295847	FITTING, elbow, 90, 3/4 mpt	2	237	109130	HOSE, coupled, 48 in.	1	
212	16T481	VALVE, check, page 85	1	238	16P244	HOSE, coupled, 3 feet	3	
213	157785	FITTING, swivel	4	239	15B772	HOSE, air, 18 inch	3	
215	171988	GASKET, inspection cap	1	240	054172	TUBE, nylon, round	12	
216	16T619	FITTING, nipple, thread on one end	1	241	054753	TUBE, nylon, round, black	8	
217	24P885	AGITATOR, assembly, air, page 80	1	242	054139	TUBE, 0.375 in. ID black nylon	5.5	
218	262857	MANIFOLD, assembly, air, page 82	1	243	115313	PLUG, tube	6	
219	26C587	SENSOR ASSEMBLY, level	2	244	126900	FITTING, 1/2 tube x 3/8 npt(m)	1	
220	24P835	PUMP, diaphragm	1	246	236425	HOSE, coupled	1	
223	262860	PANEL, assembly, air, all (A) side supply modules, page 84	1	247	16T244	VALVE, pressure relief, 3/4 in. female npt	1	
	---	PANEL, assembly, air, Model 24Y098 (B) side, page 84	1	248	---	TIE, cable, 14 in.	20	
224	113796	SCREW, flanged, hex head	8	250	126899	FITTING, compression, straight	2	
225	2002997	TANK, overflow, 2L, aluminum	1	251	112782	ELBOW, swivel, 90 degree	1	
226	245869	HEATER, Viscon, non-hazardous area (A) side only, Model 24Y097	1	252	126897	FITTING, elbow	2	
	245863	HEATER, Viscon; (A) side hazardous area unit	1	253	115764	FITTING, elbow, 90 degree	1	
227†	262868	SUPPLY, unit, 40:1, 0 volt, S20, 20L	1	254	190451	UNION, adapter	2	
	227a	26C434	PUMP AND MOTOR, see pump manual	1	255	---	LABEL, part description	1
	227b	257620	S20 RAM, see 313527	1	257	116395	FITTING, swivel, elbow	1
					258	103656	FITTING, pipe, hex	1
					259	198171	FITTING, elbow	1
					260	593538	VALVE, shuttle 1/8 nptf	1
					261	112781	ELBOW, swivel, 90 degree	1
					262	24K976	MUFFLER, 1/4 npt	1
					263	100505	BUSHING, pipe	1
					264	155665	UNION, adapter	1
					265	16R985	FITTING, nipple, 2 npt	1
					266	16R983	FITTING, adapter, 2 npt to 3/4 npt	1

Parts

Ref.	Part	Description	Qty.	
267	24P837	GASKET, agitator	1	--- Not for sale.
268	210575	CAP, filler	1	† See Supply Systems manuals 313526 and 313527 for detailed instructions and parts list for the S20 Supply Unit (262868).
269	16T245	COUPLING, shaft, one piece clamp	1	‡ Included in radar level sensor kit 26C587. See <b>Replace Radar Level Sensor</b> on page 31.
270	26C543	BLADE, agitator	1	** Included in pressure tank assembly 24M683.
272	102726	PLUG, pipe headless	1	
273	109212	SCREW, socket cap head	1	<b>NOTE:</b> 26C587 Level sensor with the blue head replaces the 24P884 sensor with the red head.
274	115219	FITTING, tee, 1/4 npt	1	26C587 includes (296, 297, 298).
275	262820	KIT, fluid outlet, flexible; page 86	1	
282	122327	FITTING, elbow, street; 3/4-14 npt	1	
296‡	156172	FITTING, union, swivel	1	
297‡	260067	FITTING, strain relief	1	
298‡	127172	CABLE, M12, 5-pin, 4-wire	1	
299	102726	PLUG, pipe, headless	1	
300**	---	GASKET, santoprene	1	
320	17D307	FITTING, nipple, quick coupling	1	
321	159239	FITTING, nipple, pipe, reducing	1	
322	158683	FITTING, elbow, 90 degree	1	
323	17D204	BRACKET, mount, Viscon Heater	1	
324	121488	SCREW, hex head, flanged	2	
325	24Y438	CABLE, assembly, armored, (non-hazardous), (A) side only	1	
	24W679	CABLE, assembly, hazardous area (A) side only	1	
326	126896	ELBOW, 1/2 in. tube x 1/2 nptf	1	
327**	420036	CLAMP, pressure pot	6	
328	17D306	FITTING, coupler, quick coupling	1	
329**	---	COVER, pressure, tank	1	
330	202659	FLUID, lubrication, 16oz (not shown)	1	
331	102040	NUT, lock, hex	4	
332	2003028	BRACKET, adapter, tank	2	
333	100157	SCREW, cap, hex, hd	4	
334	---	CONTROL, air	1	

### Heated Hose Bundle

16T121 - 3/4 in. x 1/2 in.

16T122 - 3/4 in. x 3/4 in.

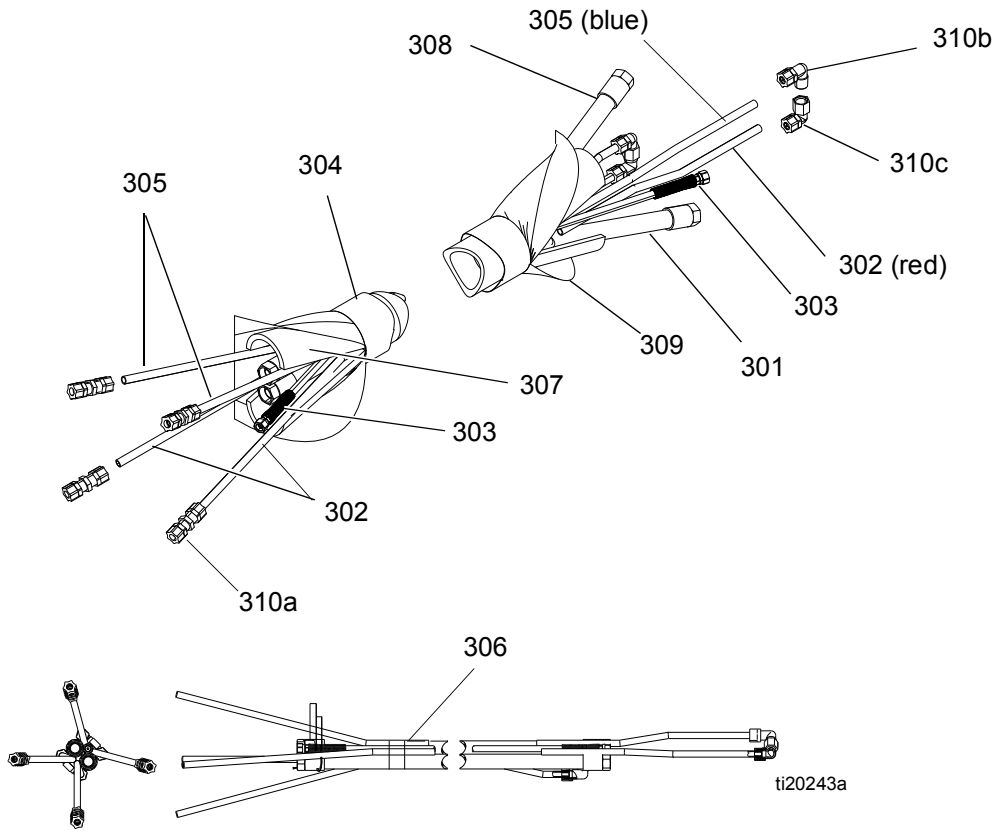

Ref.	Part	Description	Qty.	Ref.	Part	Description	Qty.
301	H77550	HOSE, coupled, 3/4 in., 6500 psi Model 16T121 Model 16T122	1 2	309	16T138	JACKET, scuff, 50 ft (15.2 m)	1
302	16X027	KIT, tube, 0.375 (9.5mm) ID red nylon	2	310	16U666	KIT, tube fittings	1
303	H42550	HOSE, coupled, 4500 psi, 1/4 in. ID, 50 ft (15.2 m)	1	310a	126894	UNION, 1/2 in. tube x 1/2 in. tube	4
304	---	LABEL, identification	1	310b	126898	ELBOW, 1/2 in. tube x 1/2 nptm	2
305	16X028	KIT, tube, 0.375 in. (9.5mm) ID blue nylon	2	310c	126896	ELBOW, 1/2 in. tube x 1/2 nptf	2
306	---	TAPE, electrical	1	311	16U111	KIT, fittings, hose connection (not shown)	1
307	---	TUBE, insulation, 2-5/8 in. ID, 50 ft (15.2 m)	1	311a	C20487	NIPPLE, hex (not shown)	2
308	H75050	HOSE, coupled, 7250 psi, 1/2 in. ID, 50 ft (15.2 m); Model 16T121 only	1	311b	158491	NIPPLE (not shown)	1
				311c	156823	UNION, swivel (not shown)	2
				311d	156971	NIPPLE, short (not shown)	1
				--- Not for sale.			

## Base System (262878, 262941) Subassemblies

### System Air Controls Module (255761)

NOTE: For Feed Module Air Panel (262860) parts, see page 84.

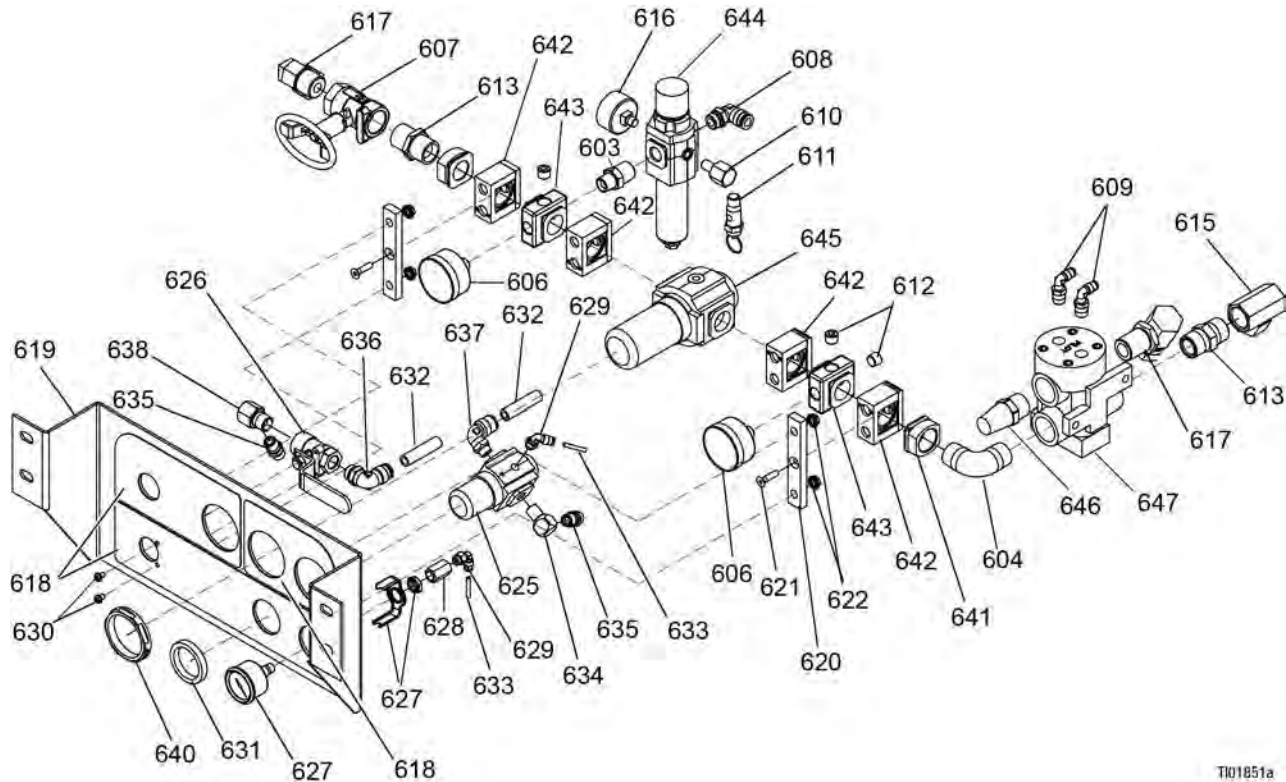

T101851a

Ref.	Part	Description	Qty.	Ref.	Part	Description	Qty.
603	157350	NIPPLE, pipe; 1/2 x 3/8 npt	1	630	100264	SCREW, machine, pan head	2
604	108307	ELBOW, pipe, male	1	631	116514	NUT, regulator	1
606	101689	GAUGE, press, air	2	632	054760	TUBE, polyurethane, round, black; 1.25 in.	-
607	117346	VALVE, ball, vented	1	633	---	TUBE, polyurethane, round; 0.6 ft.	-
608	114316	ELBOW, male, swivel	1	634	100840	ELBOW, street	1
609	114109	ELBOW, male, swivel; 1/4 OD tube	2	635	162453	FITTING; 1/4 npsm x 1/4 npt	2
610	158962	ELBOW, street; 1/4(f) x 1/8(m)	1	636	114114	ELBOW, male, swivel	1
611	116643	VALVE, safety, relief, air	1	637	114128	ELBOW, male, swivel	1
612	100721	PLUG, pipe	3	638	164259	ELBOW, street	1
613	119992	PIPE, nipple; 3/4 x 3/4 npt	2	640†	122336	NUT, panel, regulator	1
615	156589	ADAPTER, union; 90 deg.	1	641†	113440	ADAPTER	2
616	113911	GAUGE, pressure, air	1	642†	113431	CLAMP, quick	4
617	160327	ADAPTER, union; 90 deg.	2	643†	113442	BLOCK, porting	2
618	15T119	LABEL, control	1	644†	15R488	REGULATOR	1
619	---	BRACKET, air controls	1	644a	123454	FILTER, element; 5 micron	1
620	15R437	BRACKET, adapter, air controls	2	645†	15R487	REGULATOR	1
621	---	SCREW, machine, hex flat head	2	646†	15R486	MUFFLER	1
622	115942	NUT, hex, flange head	4	647†	15R485	VALVE, dual pilot	1
625	116513	REGULATOR, air	1				
626	121457	VALVE, ball, air, panel mounted	1				
627	121424	GAUGE, pressure, panel mount, 1.5 in.	1				
628	100451	COUPLING	1				
629	114151	ELBOW, male, swivel	2				

† Included in Air Controls Kit 255772 (purchase separately).

--- Not for sale.

# Purge Box (Hazardous Area Machines)

Page 1 of 4

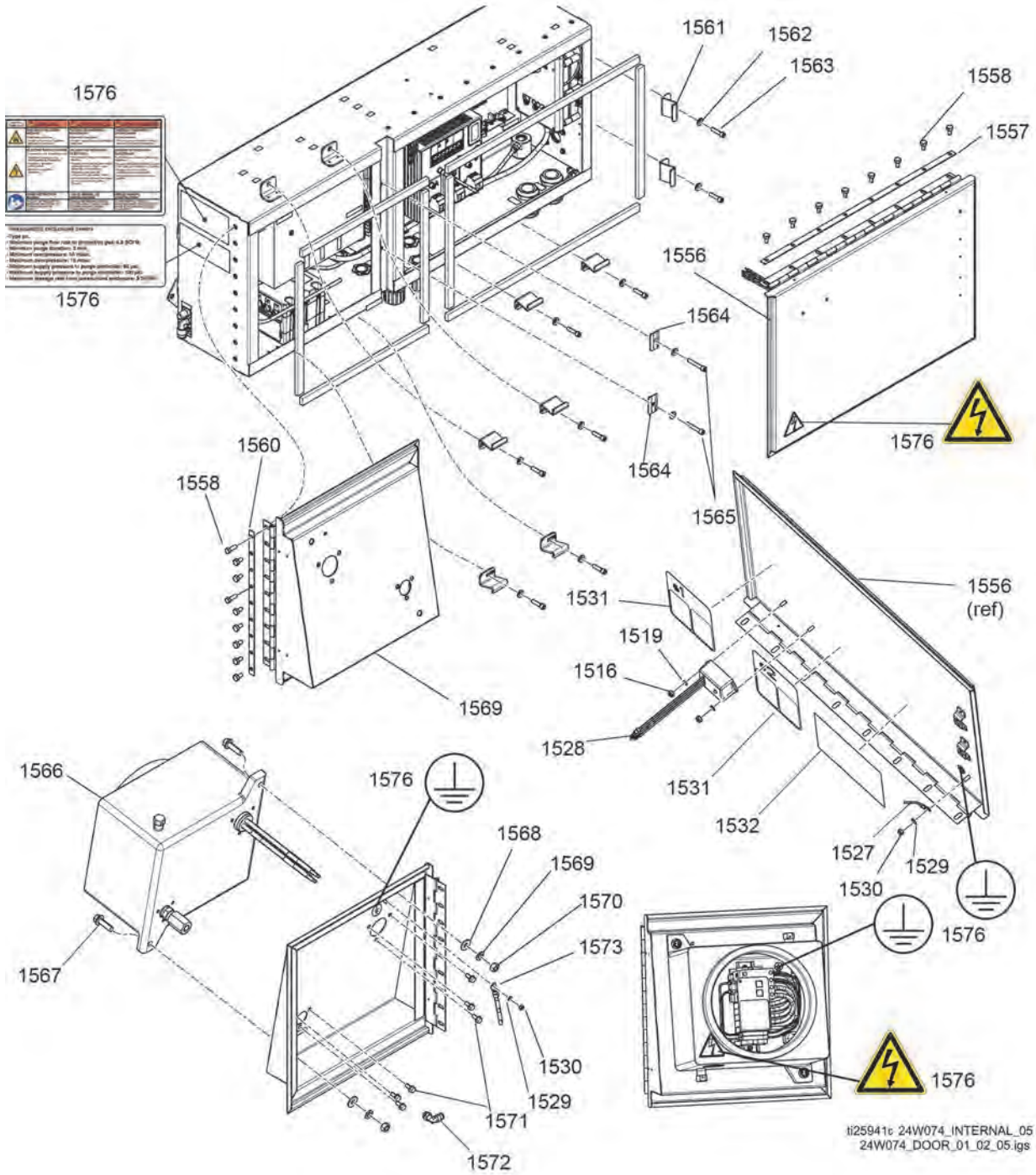

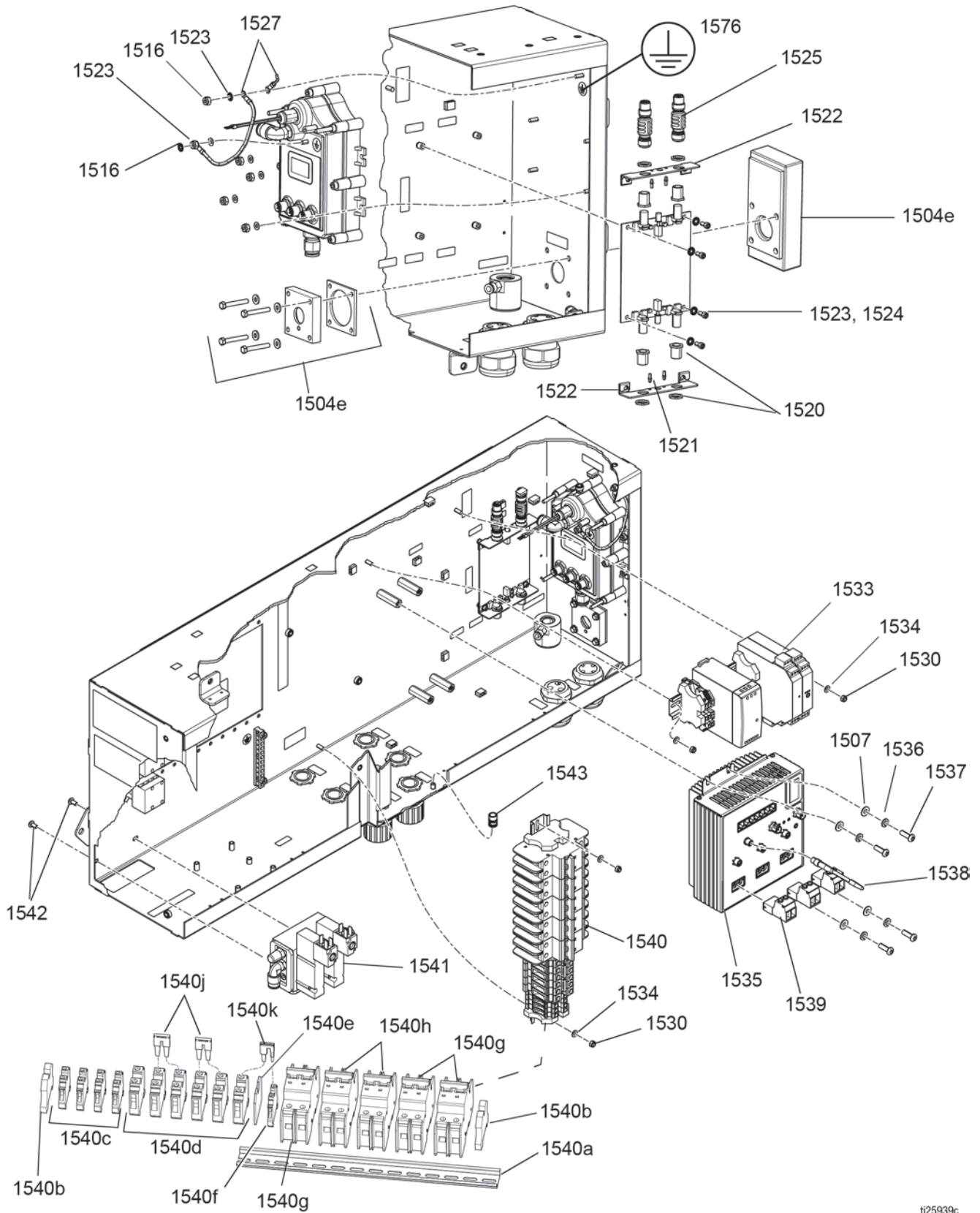

t125939c

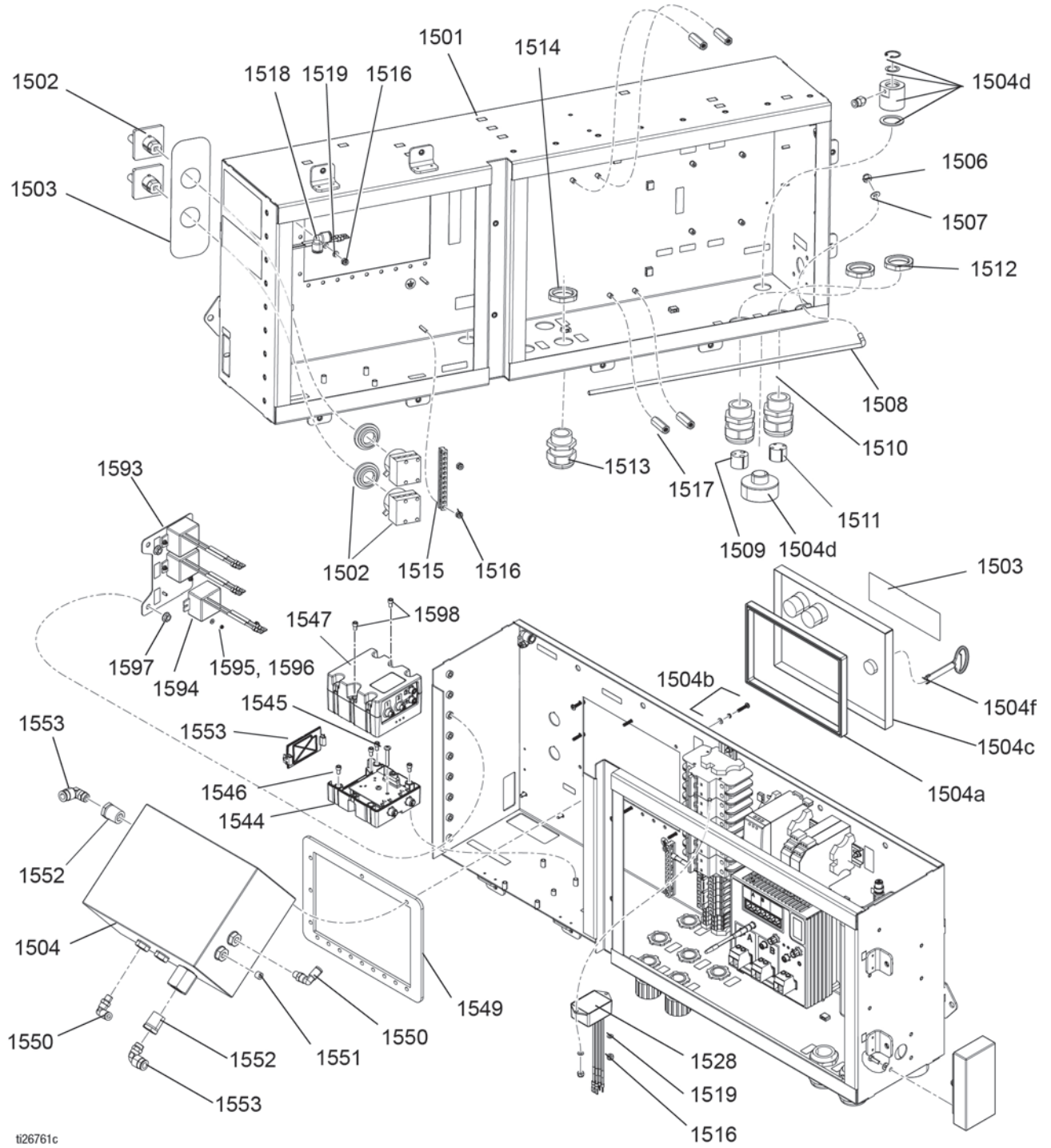

ti26761c

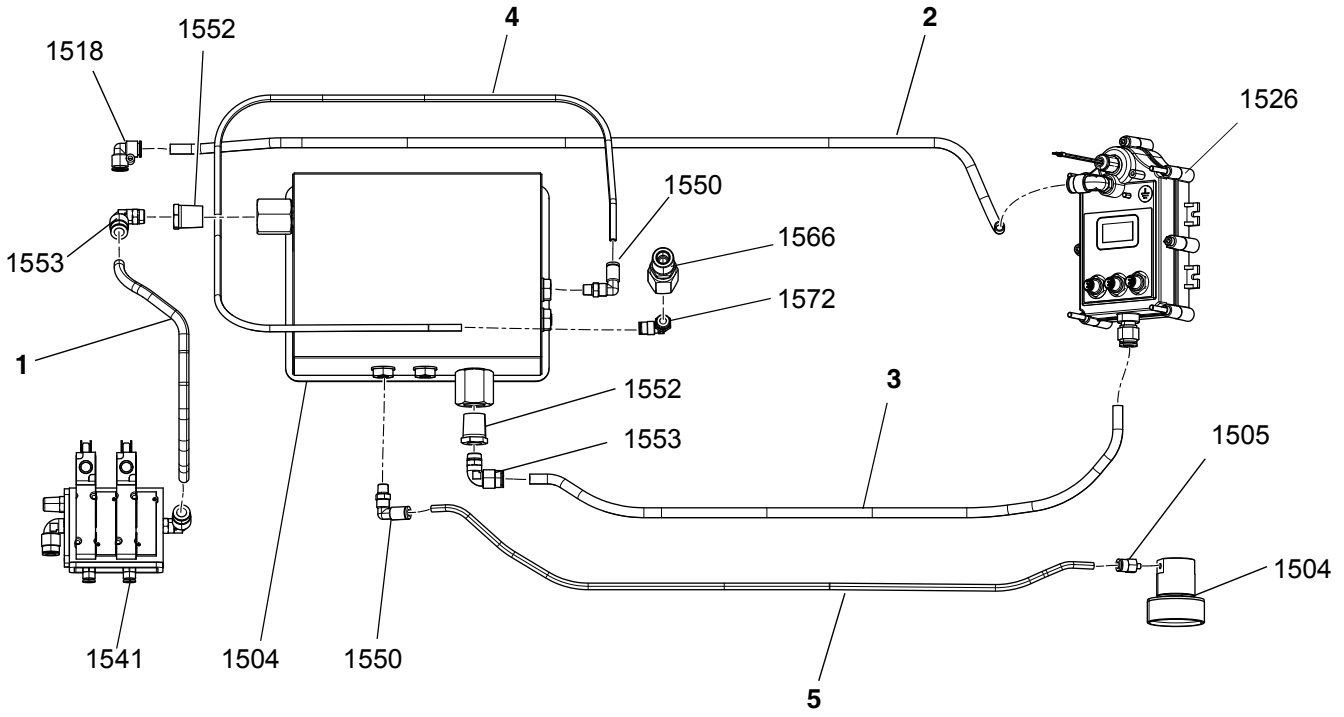

ti25945a 24W074\_AIRLINES

Tubing	Ref	Length in (mm)
1	1574	13 (330.2)
2		35 (889)
3	1575	26 (660.4)
4		39 (990.6)
5		30 (762)

**Purge Box (Hazardous Area Machines)**

Ref.	Part	Description	Qty.	Ref.	Part	Description	Qty.
1501	24W069	ENCLOSURE	1	1532	127111	ENVELOPE, packing, self-adhesive	1
1502	15U423	SWITCH, 2P, 25A	2	1533	17D228	RAIL, purge, haz loc, isolation	1
1503	17D815	LABEL, purge box, XM PFP, haz loc	1	1534	116876	WASHER, flat	4
1504	17D465	CONTROL BOX, purge	1	1535	24Y169	MODULE, gca, mzhp	1
1504a	---	GASKET, purge box door	1	1536	100016	WASHER, lock	4
1504b	---	SCREW, mounting, purge box	7	1537	112689	SCREW, button hd	4
1504c	---	DOOR, purge box	1	1538	24U109	CABLE, over-temp, switch short	1
1504d	---	ASSEMBLY, exhaust port, purge box	1	1539	24R754	CONNECTOR, power, male, 2 pin	3
1504e	---	ASSEMBLY, relief valve, purge box	1	1540	24X085	RAIL, purge, circuit breakers; includes 1540a-1540k	1
1504f	---	KEY, purge box	1	1540a	514014	RAIL	1
1505	114332	FITTING, connector, male	1	1540b	---	BLOCK, clamp end	2
1506	102040	NUT, lock, hex	1	1540c	---	BLOCK, terminal	4
1507	100086	WASHER, plain	5	1540d	126382	BLOCK, terminal	6
1508	24W820	BRACE, prop, door	1	1540e	---	BLOCK, terminal, 2 cond, 6.2 mm	1
1509	127837	GROMMET, CAN, 3 cable	1	1540f	17A314	CIRCUIT, breaker, 2P, 20A, UL489, AB	1
1510	127838	GROMMET, sensor, 4 cable	1	1540g	17A316	CIRCUIT, breaker, 2P, 30A, UL489, AB	3
1511	126881	BUSHING, strain relief	2	1540h	126384	BRIDGE, plug-in, jumper	
1512	126891	NUT, bushing	2	1540j	---	BRIDGE, plug-in jumper, reducing	2
1513	15N110	CORD, grip, 1 in.	7	1540k	24R755	CONNECTOR, power, female, 7 pin	1
1514	15N111	NUT, bushing	7	1541	17C056	MODULE, solenoid, pfp, exp proof	1
1515	122313	BAR, ground, kit	1	1542	106084	SCREW, mach, pnh	2
1516	109466	NUT, lock, hex	13	1543	24W821	MAGNET, prop, door	1
1517	17D464	NUT, coupling, hex, 1/4-20 x 1.5	4	1544	289697	MODULE, GCA, cube, base	1
1518	17D466	FITTING, push connect, 3/8 3/8 90	1	1545	126687	SCREW, mach, pnh	1
1519	107584	WASHER, plain	10	1546	104371	SCREW, cap sch; 10 x 0.375	4
1520	24M485	BOARD, assy, GCA, CAN ISO, IS	1	1547●	289696	MODULE, GCA, cube, FCM (includes 2 of 1598)	1
1521	121645	LIGHT	4	1548	277674	ENCLOSURE, cube door	1
1522	16N621	BRACKET, board, circuit	2	1549	24W073	GASKET, controller, purge	1
1523	102063	WASHER, lock, ext	6	1550	112781	ELBOW, swivel, 90°	2
1524	103229	SCREW, cap sch	4	1551	100139	PLUG, pipe	1
1525	16T072	ADAPTER, cable, CAN, IS TO NON IS	2	1552	100206	BUSHING, pipe	2
1526	24W610	MODULE, XMPFP, exp atmosphere	1	1553	115841	FITTING, elbow	2
1527	194337	WIRE, grounding, door	2	1555	17B838	STRIP, foam neoprene 0.313 x 0.625	9.5
1528	16U530	MODULE, surge protector	2	1556	24W052	ENCLOSURE, door, large	1
1529	100718	WASHER	2				
1530	115483	NUT, lock	6				
1531	17D814	LABEL, power, XM PFP, haz loc	1				

Parts

<b>Ref.</b>	<b>Part</b>	<b>Description</b>	<b>Qty.</b>
1557	24W070	ENCLOSURE, hinge, backer, long	1
1558	100333	SCREW, cap, hex hd	17
1559	24W054	ENCLOSURE, door, small	1

Ref.	Part	Description	Qty.	Ref.	Part	Description	Qty.
1560	24W072	ENCLOSURE, hinge, backer, short	1	1590	17D867	LABEL, cord wrap, XM PFP, haz loc (not shown)	1
1561	17C058	LATCH, enclosure, hd	8	1591	125871	TIE, cable, 7.5 in (not shown)	21
1562	331103	WASHER, washer	10	1593	17F587	BRACKET, line filter	1
1563	C19810	SCREW, cap, socket hd	8	1594	17F662	FILTER, line, ssr, assembly	3
1564	24W116	LATCH, enclosure, center	2	1595	188773	WASHER, flat	6
1565	596936	SCREW, cap, socket hd, 1/4 x 1.5	2	1596	C27076	NUT	6
1566	17B850	BOX, power, explosion proof, page 72	1	1597	115942	NUT, hew, flange head	2
1567	124431	SCREW, head, washer, hex, 3/8-16	2	1598	114135	SCREW, mounting manifold	2
1568	100023	WASHER, flat	2	1599	24R902	KIT, FCM3 (includes 1544, 1547, 1548, 1600) (not shown)	1
1569	100133	WASHER, lock, 3/8	2	1600	17E110	TOKEN (not shown)	1
1570	100307	NUT, hex	2	--- Not for sale.			
1571	113161	SCREW, flange, hex hd	6	▲ Replacement safety labels, tags and cards are available at no cost.			
1572	114109	FITTING, elbow, male, swivel	1	● Base electronic components do not have XM PFP-specific software installed. Therefore, use software upgrade token (485) to install software before use.			
1573	17D194	CABLE, ground, box, purge	1				
1574	C12508	TUBING, nylon, round	6.2				
1575	054172	TUBE, nylon, rd	5.75				
1576▲	17D866	LABEL, safety, purge box, multi	1				
1577	121000	CABLE, CAN, f x f, 0.5m (not shown)	1				
1578	121806	CABLE, solenoid (not shown)	2				
1579	127068	CABLE, CAN, female/female 1.0m (not shown)	2				
1580	17D197	CABLE, sensor, ISO to level, A (not shown)	1				
1581	17D198	CABLE, sensor, ISO to level, B (not shown)	1				
1582	17D199	CABLE, sensor, ISO to RTD, hose (not shown)	1				
1583	17D200	CABLE, sensor, ISO to RTD, heater (not shown)	1				
1584	17D201	CABLE, sensor, ISO to FCM 3, tank level (not shown)	1				
1585	17D202	CABLE, sensor, ISO to FCM3, RTD (not shown)	1				
1586	17D257	CABLE, I.S. CAN, fem-fem, 1.5m (not shown)	1				
1587	17D260	CABLE, GCA, I.S., CAN, m/f, 1.6m (not shown)	1				
1588	17D261	CABLE, male A to fem B code, 1.9m (not shown)	1				
1589	24R735	CABLE, CAN power, m12 fem, pigtail (not shown)	1				

### Explosion Proof Power Box (Hazardous Area Machines)

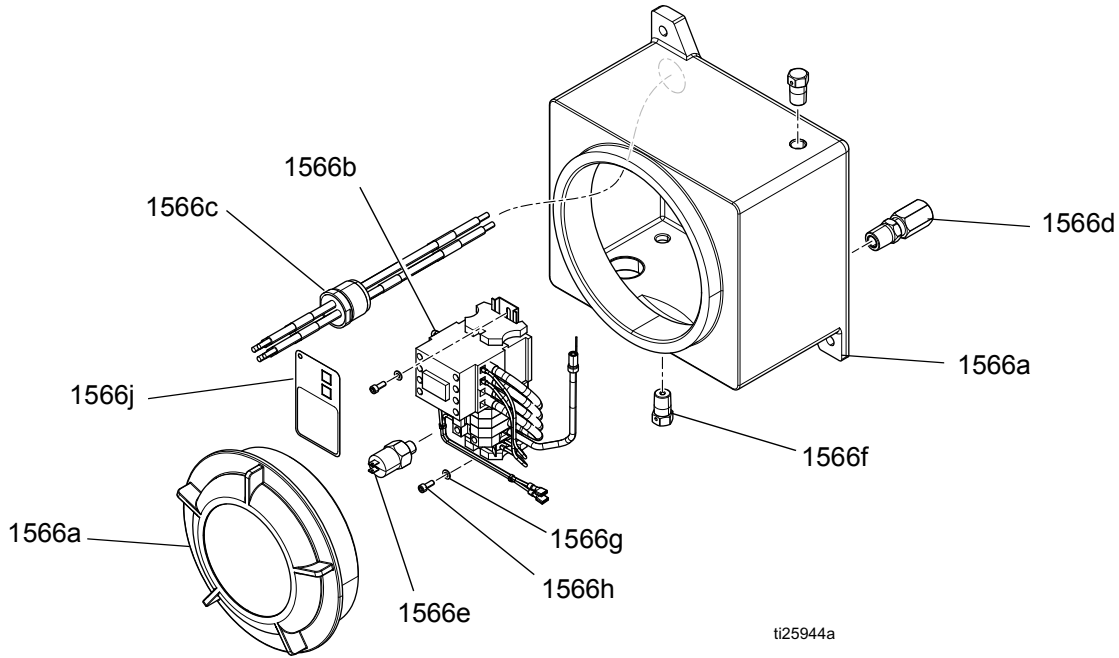

ti25944a

Ref.	Part	Description	Qty.
1566a	17B849	BOX, explosion proof	1
1566b	17B848	RAIL, power, disconnect	1
1566c	17B984	BUSHING, line	1
1566d	17B982	FITTING, arrestor, flame	1
1566e	17B983	SWITCH, pressure	1
1566f	24X158	BREATHER, drain	2
1566g	116876	WASHER, flat	2
1566h	120039	FASTENER, schs, 10-32 x 1/2 in.	2
1566j	17D816	LABEL, hang tag, XM PFP, haz	1
1566k	125871	TIE, cable 7.5 in	1

### Junction Box (Non-Hazardous Area Machines)

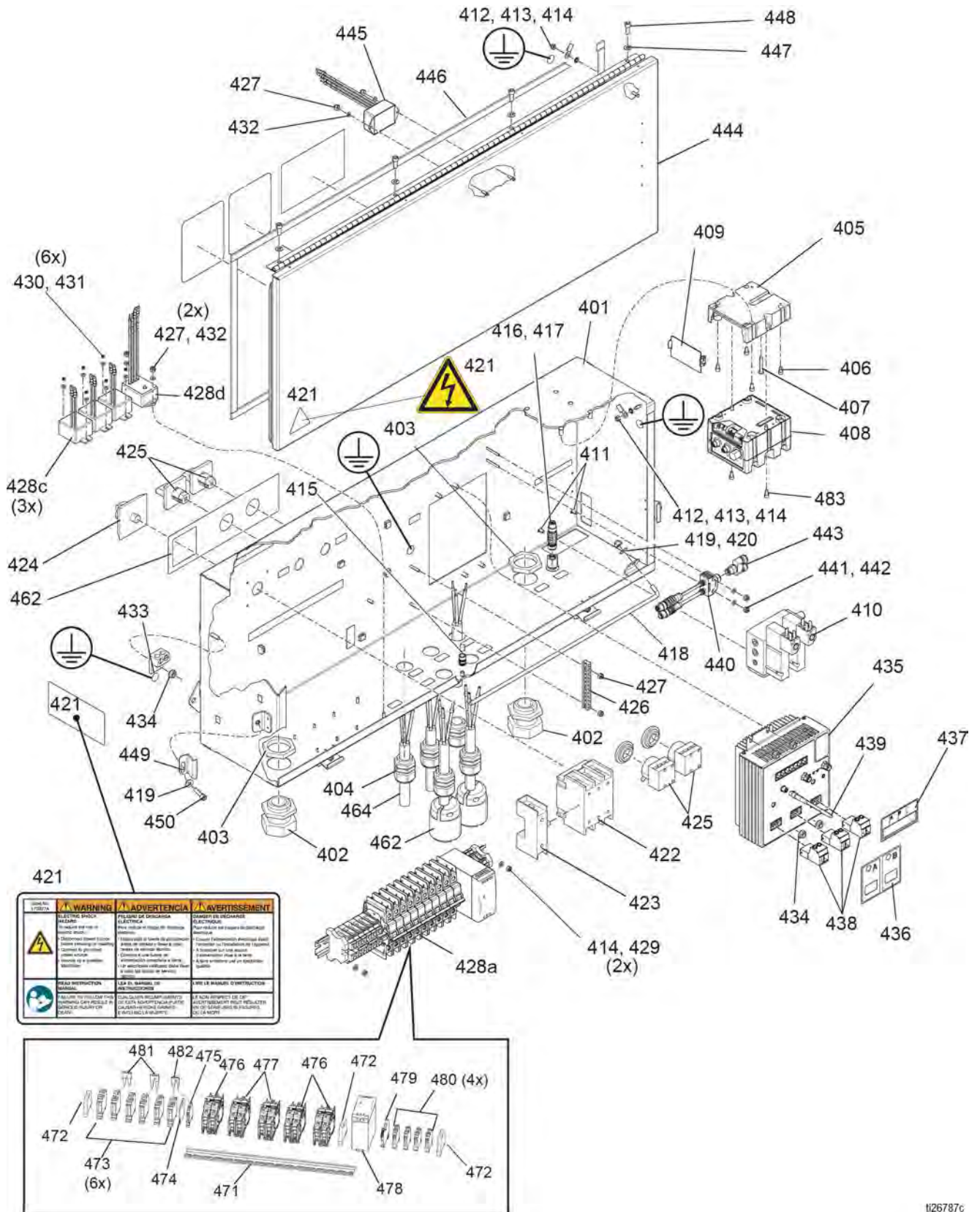

Model No. 1226787C	⚠️ WARNING	⚠️ ADVERTENCIA	⚠️ AVERTISSEMENT
	<b>ELECTRIC SHOCK</b> Risk of electric shock. Disconnect power before working on this equipment. Do not touch live parts. Use proper safety procedures. See the manual for more information.	<b>Peligro de Choque Eléctrico</b> Riesgo de choque eléctrico. Desconecte el suministro de energía antes de trabajar en este equipo. No toque las partes vivas. Utilice los procedimientos de seguridad adecuados. Consulte el manual para obtener más información.	<b>DANGER DE DÉCHARGE ÉLECTRIQUE</b> Risque de décharge électrique. Déconnectez l'alimentation avant de travailler sur cet équipement. Ne touchez pas les parties sous tension. Utilisez les procédures de sécurité appropriées. Consultez le manuel pour plus d'informations.
	<b>READ INSTRUCTIONS</b> Read the manual for important safety information.	<b>LEE EL MANUAL DE INSTRUCCIONES</b> Consulte el manual para obtener información importante sobre seguridad.	<b>LIRE LE MANUEL D'INSTRUCTIONS</b> Lisez le manuel pour obtenir des informations importantes sur la sécurité.

Parts

**Junction Box (Non-Hazardous Area Machines)**

Ref.	Part	Description	Qty.				
				436	17F844	LABEL, ID, multi-zone, lower a b	1
				437	17F921	LABEL, ID, multi-zone, upper a b	1
				438	24R754	CONNECTOR, power, male, 2 pin	3
				439	24U109	CABLE, over-temp, switch short	1
				440	126495	CABLE, splitter, 4-20ma, 2 circuit	1
				441	151395	WASHER, flat	2
				442	C19862	NUT, lock, hex	1
				443	124273	CONNECTOR, splitter	1
				444	17G504	DOOR, weldment	1
				445	16U530	MODULE, sys surge protector	1
				446	070689	STRIP, foam, neoprene	8
				447	100016	WASHER, lock	4
				448	121112	SCREW, cap, socket head	4
				449	17G423	CLAMP, door latch	4
				450	C19810	SCREW, cap, socket hd	4
				451	24Y439	WIRE, chassis ground (not shown)	1
				452	125789	CABLE, can, f x f, 0.5M (not shown)	2
				453	126494	CABLE, M12, 5p, 4 wire with drain (not shown)	2
				454	121806	CABLE, solenoid (not shown)	2
				455	24R735	CABLE, can power, m12 fem, pigtail (not shown)	1
				456	126511	CABLE, gca, m8, 4-pin, 1.5m, m x f, mold (not shown)	2
				457	125806	CABLE, splitter, m8, 4-pin, ffm 1.5M (not shown)	1
				458	16T439	LABEL, cord wrap (not shown)	1
				460	125871	TIE, cable, 7.50 inch (not shown)	14
				462	24Y480	CABLE, assembly, junction box (not shown)	2
				464	24Y437	CABLE, assembly, Viscon heater	3
				471	16T119	RAIL, mounting, 16 in.	1
				472	120838	BLOCK, clamp end	3
				473	126382	BLOCK, terminal	6
				474	126383	COVER, end	1
				475	24X086	BLOCK, terminal, 2 cond, 6.2 mm	1
				476	17A314	CIRCUIT, breaker, 2P, 20A, UL489, AB	3
				477	17A316	CIRCUIT, breaker, 2P, 30A, UL489, AB	2
				478	126453	POWER SUPPLY, 24V	1
				479	24R722	BLOCK, terminal PE, quad, AB	1
				480	17D195	BLOCK, terminal, 2 cond, 8.2 mm	4
				481	126384	BRIDGE, plug-in, jumper	2
				482	24X087	BRIDGE, plug-in, jumper, rdng	1
				483	114135	SCREW, mounting manifold	2
				484	24R902	KIT, FCM3 (includes 405, 408, 409, 485) (not shown)	1
				485	17E110	TOKEN (not shown)	1
401	---	ENCLOSURE, weldment	1				
402	120858	BUSHING, strain relief, m40 thread	2				
403	120859	NUT, strain relief, m40 thread	2				
404	121603	GRIP, cord, 0.51-0.71, 3/4	5				
405	289697	MODULE, gca, cube, base	1				
406	104371	SCREW, cap sch 10 x 0.375	4				
407	126687	SCREW, mach, pnh	1				
408 ●	289696	MODULE, GCA, cube, FCM (includes 2 of 483)	1				
409	277674	ENCLOSURE, cube door	1				
410	262856	MODULE, solenoid, pfp	1				
410a	121636	VALVE, solenoid	2				
410b	15A798	GASKET, outlet	1				
410c	15A799	GASKET, inlet	1				
411	106084	SCREW, mach, pnh	2				
412	555629	WASHER, #10 external tooth lock	2				
413	194337	WIRE, grounding, door	1				
414	115483	NUT, lock	4				
415	24W821	MAGNET, prop, door	1				
416	126496	CONNECTOR, thru, m12, mx, reverse key	1				
417	16T072	ADAPTER, cable, can, is to non is	1				
418	24W820	BRACE, prop, door	1				
419	331103	WASHER, washer 0.562 0.250 0.060.st	5				
420	102040	NUT, lock, hex	1				
421 ▲	17G327	LABEL, safety, junction	1				
422	123969	SWITCH, disconnect, 100 amp	1				
423	123968	SWITCH, disconnect, 100 amp	1				
424	123967	KNOB, operator disconnect	1				
425	15U423	SWITCH, 2p, 25a	2				
426	122313	BAR, ground, kit	1				
427	109466	NUT, lock, hex	6				
428	---	RAIL, breaker assembly	1				
428a	24Y294	RAIL, circuit breaker (includes 471-482)	1				
428b	24R755	CONNECTOR, power, female (not shown)	1				
428c	17H081	FILTER, line, ssr assembly	3				
428d	16U530	MODULE, system surge protector	1				
428e	---	FERRULE, wire, 10 awg (not shown)	24				
429	116876	WASHER, flat	2				
430	188773	WASHER, flat	6				
431	C27076	NUT	6				
432	107584	WASHER, plain	2				
433	117666	TERMINAL, ground	1				
434	115942	NUT, hex, flange head	5				
435 ●	24Y169	MODULE, gca, mzhp	1				

▲ Replacement safety labels, tags and cards are available at no cost.

--- Not for sale.

- *Base electronic components do not have XM PFP-specific software installed. Therefore, use software upgrade token (485) to install software before use.*
- † *Includes software token (485) and instruction sheet.*

### Control Box (255771)

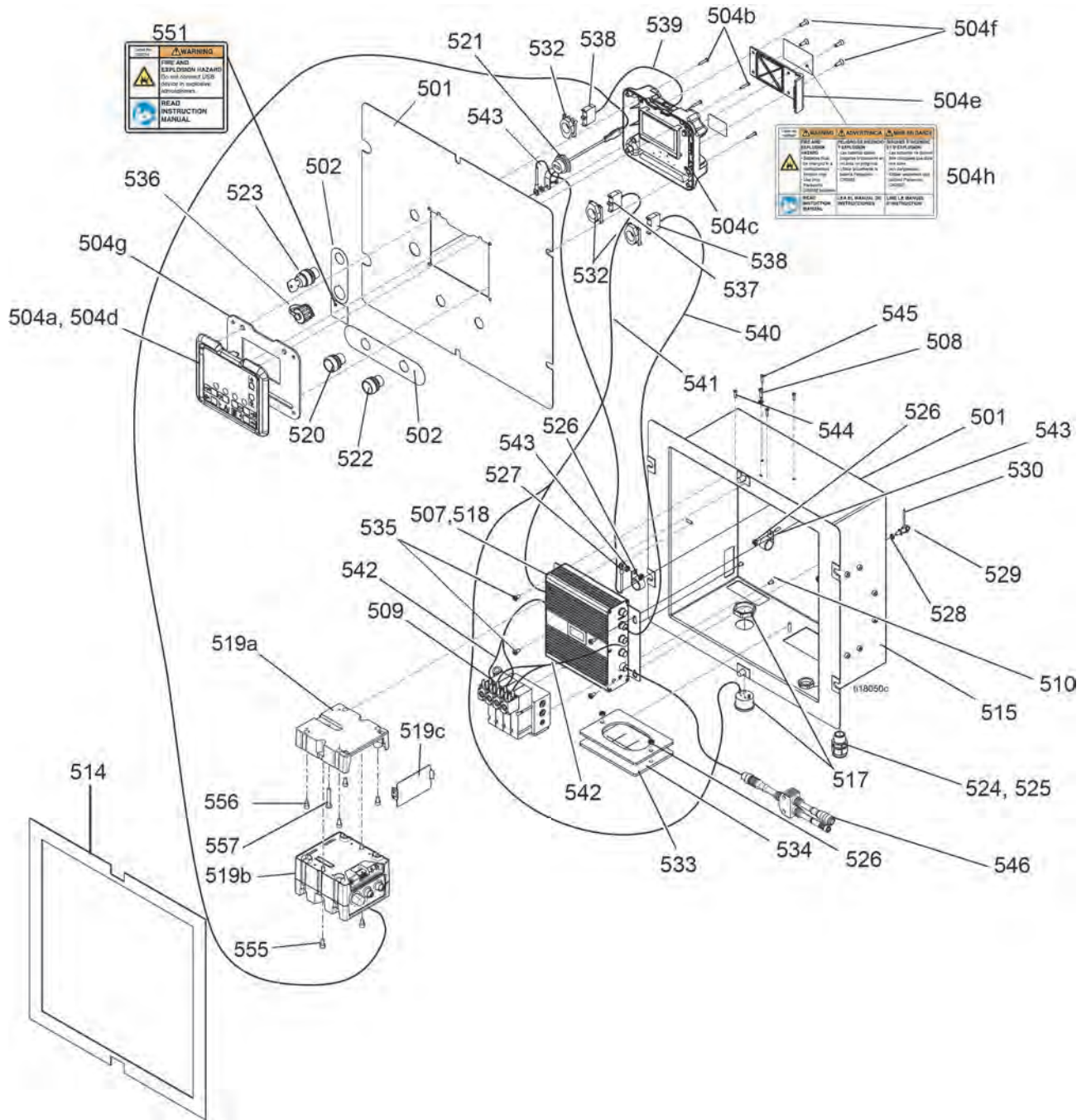

Ref.	Part	Description	Qty.	Ref.	Part	Description	Qty.
501	---	BOX, control	1	523a	123412	KEY, replacement (not shown)	1
502	---	LABEL, control display	1	524	117745	BUSHING, strain relief (pair)	1
503†‡	262641	KIT, replacement, USB (includes 506, 519) (not shown)	1	525	117625	NUT, locking	1
504‡	257484	MODULE, display, kit (includes 504a, 504b, 504c, 504d, 504e, 504f, 504g, 504h)	1	526	113505	NUT, keps, hex head	6
504a	15M483	SHIELD, membrane, display (qty. 10)	1	527	15B090	WIRE, grounding, door	1
504b	121946	SCREW, pan hd, #6 x 7/8 in.	4	528	---	WASHER, lock, external, 1/4 in.	1
504c‡	288997	CASE, rear, display module, IS version	1	529	15R343	CLAMP, ground, electrical	1
504d	255727	CASE, front, data module	1	530	---	WIRE, copper	3
504e	277463	COVER, access, low level display	1	531	172953	LABEL, designation (not shown)	2
504f	113768	SCREW, socket, flat head	4	532	120493	LATCH, mounting	3
504g	15R458	GASKET, control, front	1	533	15H189	BOOT, wire feed through	1
504h▲	15W958	LABEL, warning, panel battery	1	534	15G816	COVER, plate, wire	1
505†‡	262642	KIT, replacement, display (includes 504, 506)	1	535	110637	SCREW, machine, pan head	4
506	17E110	TOKEN, software (not shown)	1	536	15R325	COVER, dust, bulkhead, receptacle	1
507†‡	262643	KIT, replacement, FCM (includes 506, 518)	1	537	120494	BLOCK, switch, normally open	2
508	---	SCREW, pan head	4	538	120495	BLOCK, switch, normally closed	4
509	256555	MODULE, solenoid, IS version	1	539	15M974	HARNESS, key switch	1
509a	121636	VALVE, solenoid, din connector (includes 2 of 509d) (not shown)	4	540	15M975	HARNESS, start/alarm	1
509b	15A798	GASKET, solenoid, outlet (not shown)	1	541	15M976	HARNESS, stop	1
509c	15A799	GASKET, solenoid, inlet/exhaust (not shown)	1	542	15M977	HARNESS, solenoid	1
509d	---	SCREW (not shown)	8	543	121988	RETAINER, routing, wire harness	1
510	106084	SCREW, machine, pan head	2	544	195875	SCREW, machine, pan head	1
514	15R379	GASKET, box, control	1	545	102063	WASHER, lock	1
515	---	LABEL	1	546	15U542	CABLE, motor	2
516	15B056	LABEL, air motor/dosing valve (not shown)	1	551▲		LABEL, warning, lock	1
517	122000	ALARM, panel mount	1	552	15X214	English (not shown)	-
518‡	255920	MODULE, fluid control	1	553	15X393	LABEL, warning, USB (not shown)	1
519‡	257088	MODULE, USB, assy. (includes 519a, 519b, 519c) (not shown)	1	554	122829	CONDUIT, 0.75 ft (not shown)	-
519a	289899	BASE	1	555	114135	SCREW, mounting, manifold	2
519b‡	289900	MODULE, USB (includes 2 of 555)	1	556	104371	SCREW, cap sch 10x.375	4
519c	277674	DOOR, module	1	557	126687	SCREW, mach, pnh	1
520	121618	SWITCH, start, push button, green	1	▲ Replacement safety labels, tags, and cards are available at no cost.			
521	15R324	HARNESS, USB, plug/bulkhead; 32 in.	1	--- Not for sale.			
522	121619	SWITCH, stop, push button, red	1	‡ Base electronic components do not have XM PFP-specific software installed. Therefore, use software upgrade token (506) to install software before use.			
523	121617	SWITCH, 2 position, key, controls	1	† Includes software token (506) and instruction sheet.			

### Air Filter (24P899)

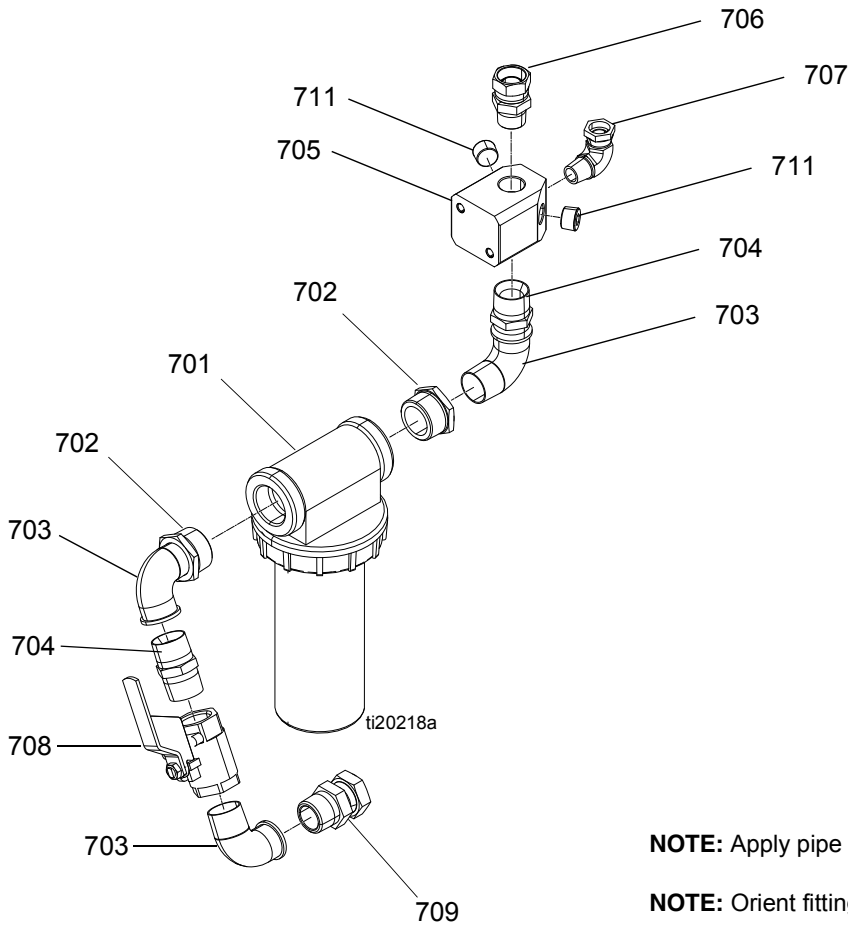

**NOTE:** Apply pipe sealant to all non-swiveling pipe threads.

**NOTE:** Orient fittings approximately as shown.

Ref.	Part	Description	Qty.
701	16T236	FILTER, air, 1-1/4, auto drain	1
701a	106204	FILTER ELEMENT (not shown)	1
702	---	BUSHING, 1-1/4 x 1 npt carbon steel	2
703	110300	FITTING, elbow, street, pipe	3
704	158585	FITTING, nipple	2
705	16R951	MANIFOLD, air distribution	1
706	157785	FITTING, swivel	1
707	C19024	FITTING, elbow, swivel	1
708	113163	VALVE, ball, vented, 1.00 in.	1
709	160022	FITTING, union, adapter	1
710	---	SEALANT, pipe, stainless steel	1
711	100361	PLUG, pipe	2

--- Not for sale.

### Ratio Control Valve Assemblies (262887, 262888)

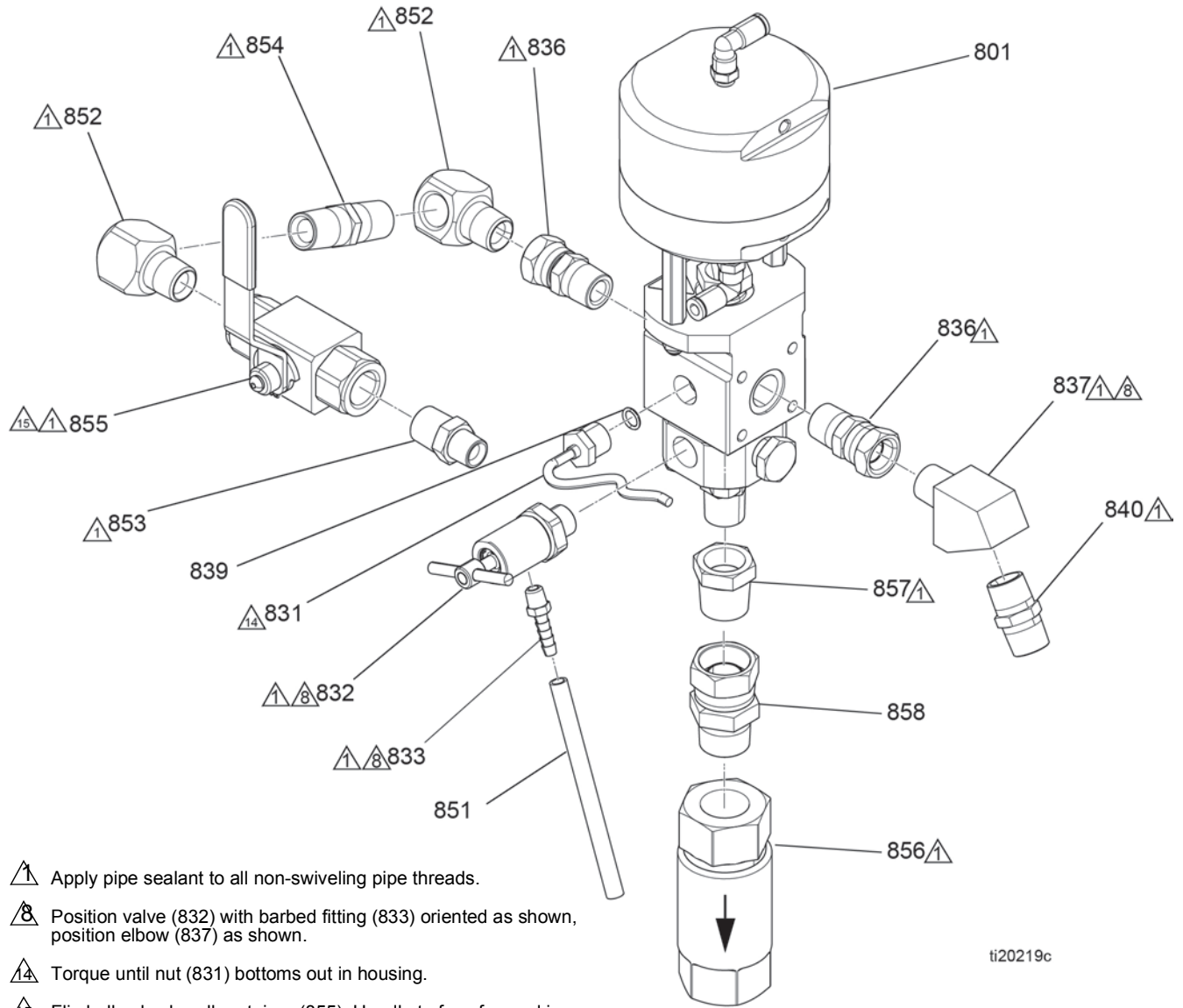

- Apply pipe sealant to all non-swiveling pipe threads.
- Position valve (832) with barbed fitting (833) oriented as shown, position elbow (837) as shown.
- Torque until nut (831) bottoms out in housing.
- Flip ball valve handle retainer (855). Handle to face forward in open position.

ti20219c

Ref.	Part	Description	Qty.	Ref.	Part	Description	Qty.
801†	255478	VALVE, dosing	1	853	159239	FITTING, nipple, pipe, reducing (B side only)	1
831	15M669	SENSOR, pressure, fluid outlet	1	854	156877	FITTING, nipple, long	1
832	2002400	VALVE, pressure, bleed, PFP	1	855	2001446	VALVE, ball, 1/2 in.	1
833	116746	FITTING, barbed, plated	1	856	16T481	VALVE, check; see page 85	1
836	156684	FITTING, union, adapter	2	857	16C475	FITTING, bushing, pipe	1
837	15M987	FITTING, elbow, 60 degree	1	858	157785	FITTING, swivel	1
839	121399	PACKING, o-ring	1				
840	158491	FITTING, nipple (B side only - Qty 1) (A side only - Qty 2)					
851	116750	TUBE, nylon	1				
852	158683	FITTING, elbow, 90 degree	2				

† See Dosing Valve Instructions - Parts manual referenced on page 4 for further details.

# Feed Module Sub-Assemblies

## Air Powered Agitator (273299)

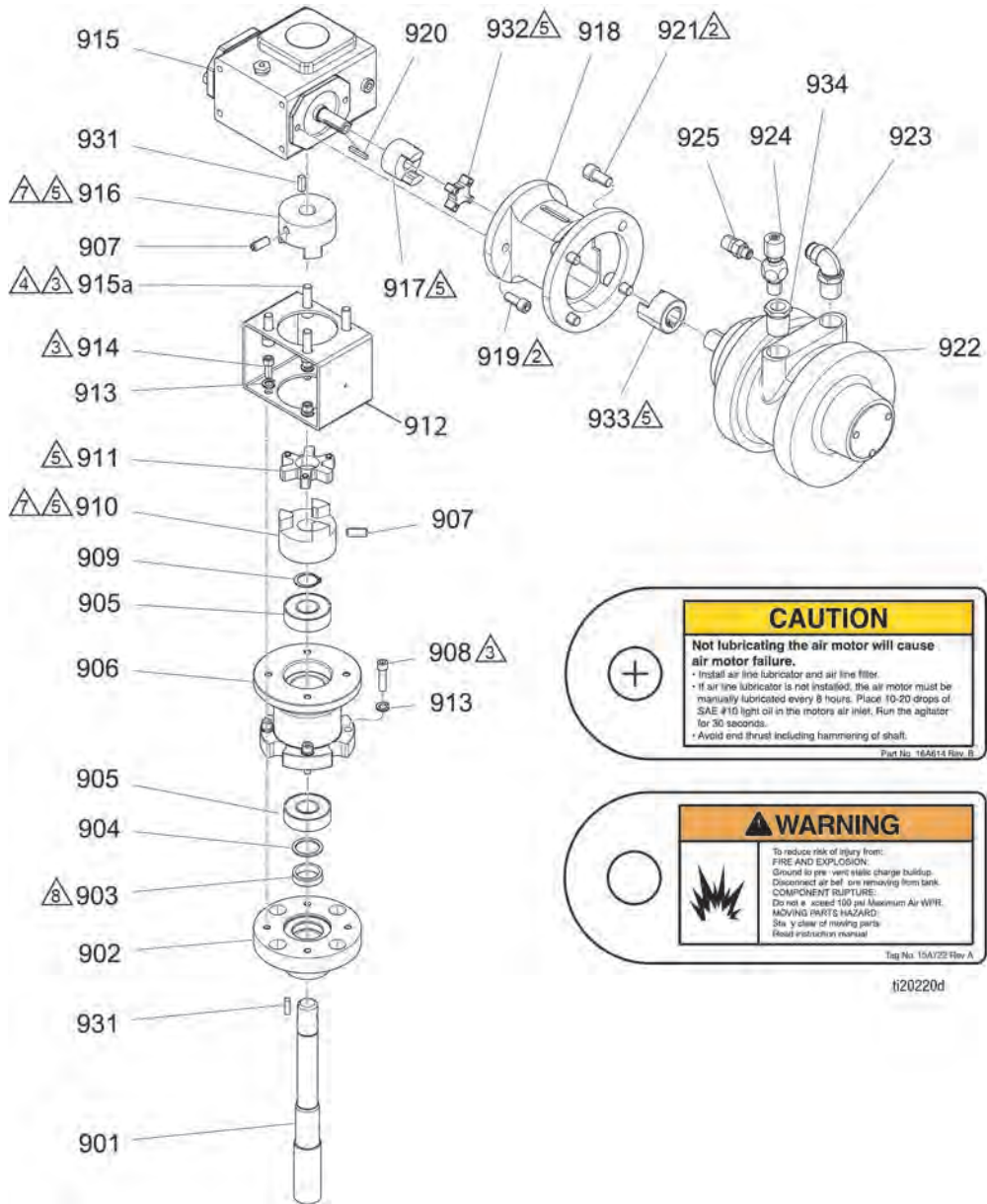

- ⚠ Apply low strength threadlocker.
- ⚠ Apply medium strength thread locker.
- ⚠ Remove four screws from gear reducer (915), pass them through bracket (912) and back into gear reducer (915) then torque to 150-170 in-lb (17-19 N•m).
- ⚠ Leave a 0.015 in. gap between each half of couplings (910, 911, 916, 917, 932, 933).

- ⚠ When ordering a replacement coupling: Remove set screw supplied with couplings (910, 916) and discard. Replace with set screw (907) from original couplings.
- ⚠ Open side of u-cup seal (903) must face down inside housing (902).

**NOTE:** Apply pipe sealant to all non-swiveling pipe threads.



i20220d

**Air Powered Agitator (273299)**

Ref.	Part	Description	Qty.
901	16P919	SHAFT, AGITATOR	1
902	16U219	HOUSING, AGITATOR	1
903	122772	SEAL, 0.875X1.125, PTFE	1
904	15Y360	SPACER, SEAL, SHAFT, ASME, AGIT	1
905	122774	BEARING, BALL, 3/4BOREX1-3/4DIAX1/2	2
906	16P920	HOUSING, BEARING, AGITATOR	1
907	125303	SCREW, SHSS, 5/16-18 X 0.75	2
908	112222	SCREW, CAP.SCH	4
909	122776	RING, RET, EXT, 0.750, MS	1
910	122761	COUPLING, ALIGNMENT, HUB	1
911	122760	COUPLING, ALGNMNT, DISK, HYTREL	1
912	16P922	BRACKET, ADAPTER, AGITATOR, PAINTED	1
913	C19209	WASHER, LOCK	8
914	121112	SCREW, CAP, SOCKET HEAD	4
915	181794	GEAR, REDUCER	1
915a	---	SCREW, CAP.SCH	4
916	16P923	COUPLER, ADAPTER	1
917	133350	COUPLER, FLEXIBLE, HUB, 1/2	1
918	19C944	ADAPTER, AIR MOTOR TO GEARBOX	1
919	129551	SCREW, 5/16-18 X 0.75	2
920	564142	KEY, SQUARE, 0.125 X 0.875 LG	1
921	551204	SCREW, SHCS 3/8 X 3/4	4
922	101487	MOTOR, AIR	1
923	126898	FITTING, PTC, ELBOW, 1/2 MPT, 3/8 OD	1
924	206264	VALVE, NEEDLE	1
925	16D939	FITTING, NIPPLE, REDUCING	1
926	070408	SEALANT, PIPE, SST	1
927	070311	SEALANT, ANAEROBIC	1
928	070269	SEALANT, ANAEROBIC, BLUE	1
929▲	17Z460	TAG, SAFETY, WARNING, MULTIPLE	1
930▲	16A614	TAG, LABEL, CAUTION	1
931	120376	KEY, SQUARE, 0.188	2
932	133351	COUPLER, FLEXIBLE, SPIDER GEAR	1
933	133349	COUPLER, FLEXIBLE, HUB, 3/4	1
934	100206	BUSHING, PIPE	1

--- Not for sale.

▲ Replacement safety labels, tags and cards are available at no cost.

### Tank Air Manifold Assembly (262857)

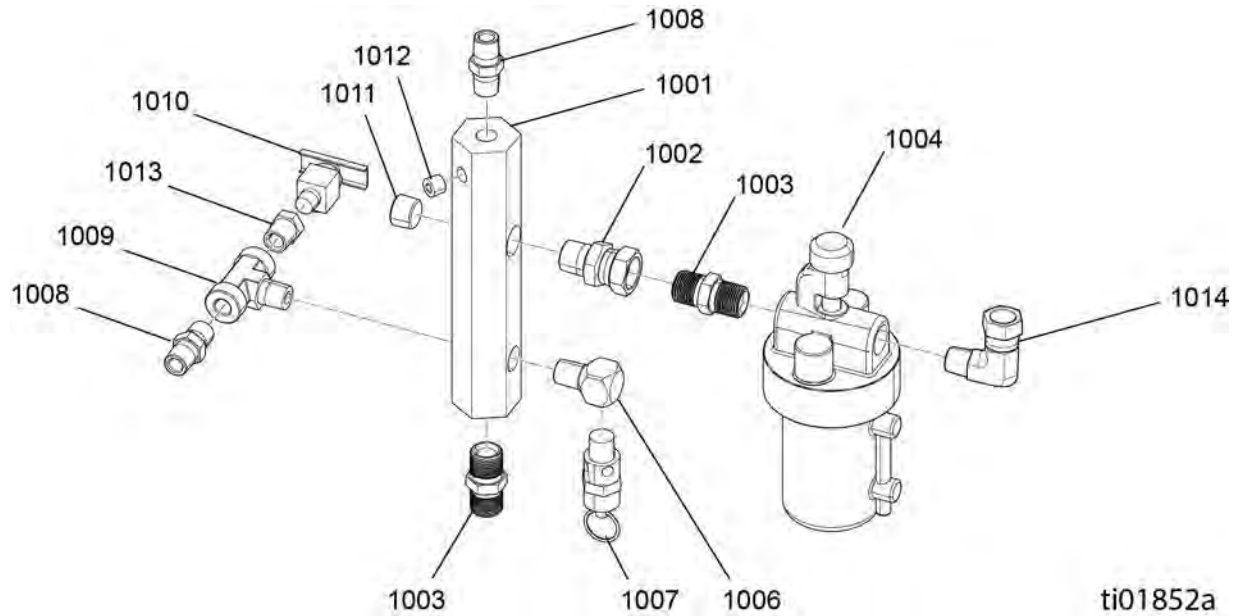

ti01852a

**NOTE:** Apply pipe sealant to all non-swiveling pipe threads.

**NOTE:** Orient fittings approximately as shown.

Ref.	Part	Description	Qty.
1001	189016	MANIFOLD, air, inlet	1
1002	155665	UNION, adapter	1
1003	156849	PIPE, nipple	2
1004	214847	LUBRICATOR, air line	1
1006	100840	FITTING, elbow, street	1
1007	116643	VALVE, safety, 90 psi	1
1008	156971	FITTING, nipple, short	2
1009	108638	FITTING, pipe, tee	1
1010	101759	FITTING, drain cock	1
1011	101754	PLUG, pipe	1
1012	100139	PLUG, pipe	1
1013	100030	BUSHING	1
1014	155494	FITTING, elbow, street	1
1015	---	SEALANT, pipe, stainless steel	1

--- Not for sale.

**Static Mixer (16T316)**

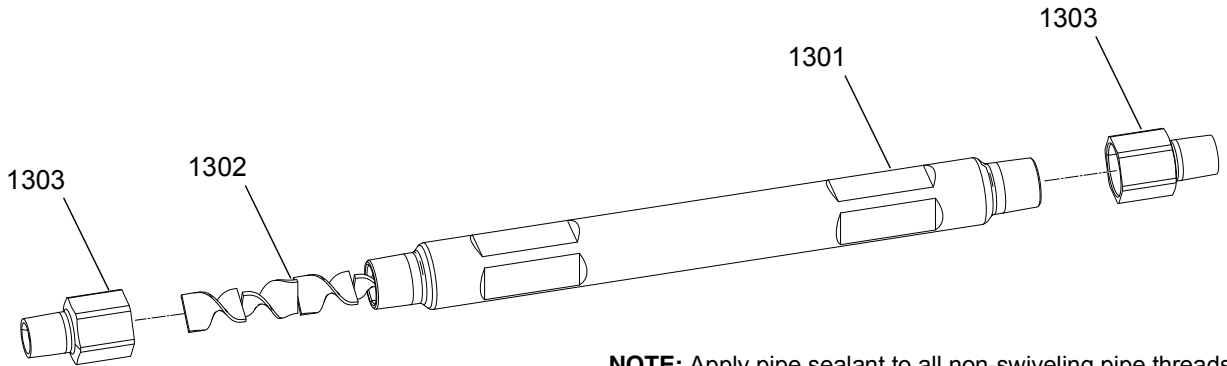

**NOTE:** Apply pipe sealant to all non-swiveling pipe threads.

Ref.	Part	Description	Qty.
1301	16T116	TUBE, mixer	1
1302	24P886	MIXER, 12 element, stainless steel	1
1303	16T315	BUSHING, reducing 3/4 nptf x 1/2 npt	2
1304	---	SEALANT, pipe, stainless steel	1

--- Not for sale.

### Feed Module Air Panel (262860)

**NOTE:** For **System Air Controls Module (255761)** parts, see page 64.

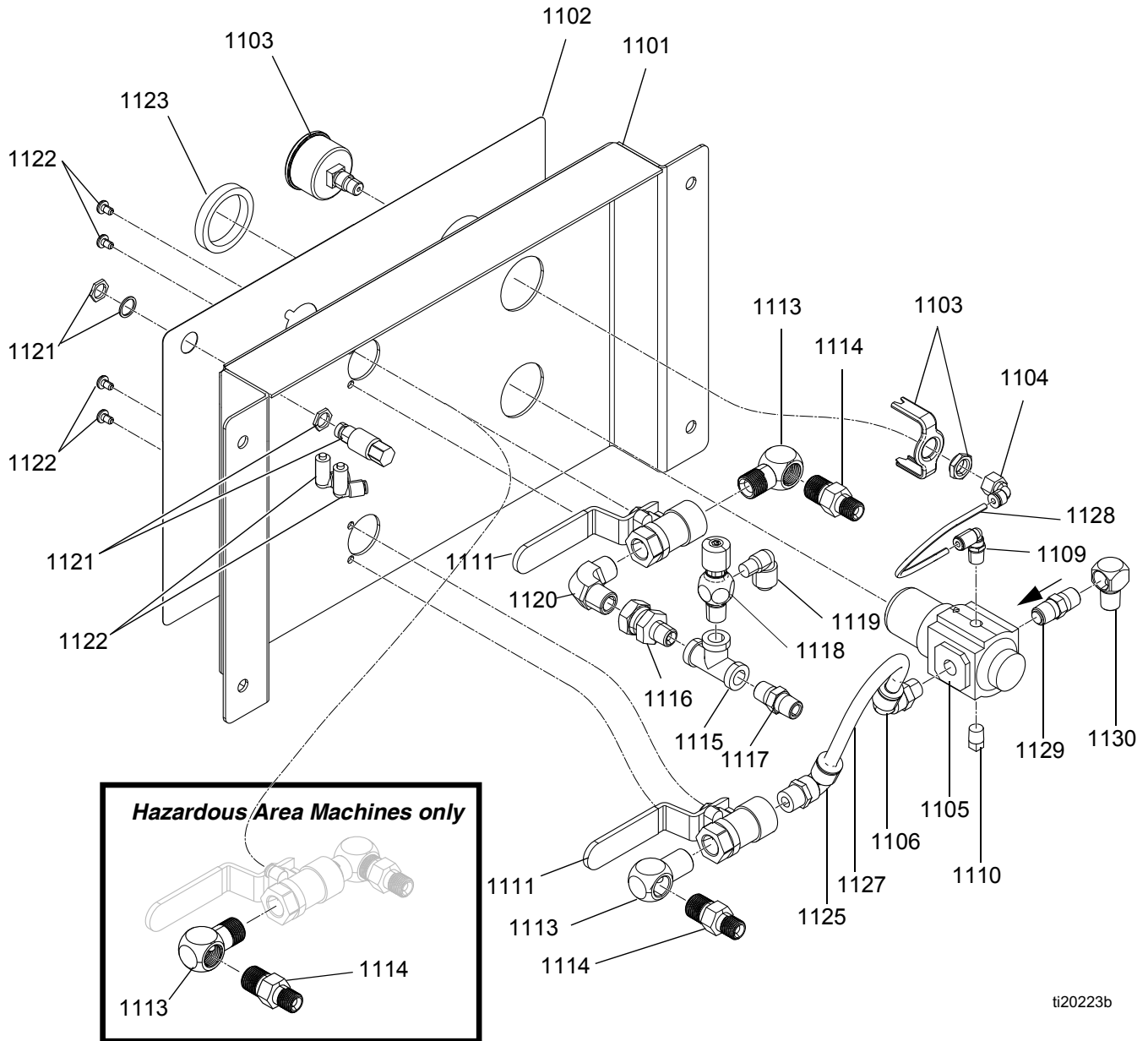

ti20223b

**NOTE:** Apply pipe sealant to all non-swiveling pipe threads.

**Air Panel**

Ref.	Part	Description	Qty.
1101	---	BRACKET, air control	1
1102	---	LABEL, instructions	1
1103	121424	GAUGE, pressure, panel mount, 1.5 in.	1
1104	15T498	FITTING, 90 degree, swivel, 5/32 in. tee x 1/8 in. female npt	1
1105	116513	REGULATOR, air	1
1106	121141	FITTING, elbow, swivel, 3/8 tee, 1/4 in. male npt	1
1109	198171	FITTING, elbow	1
1110	100403	PLUG, pipe	1
1111	121457	VALVE, ball, air, panel mounted	2
1113	155699	FITTING, elbow, street (262860: Qty 2) (262844: Qty. 3)	
1114	165198	FITTING, nipple, reducing (262860: Qty 2) (262844: Qty. 3)	
1115	104984	FITTING, tee, pipe	1
1116	157705	UNION, swivel	1
1117	156971	FITTING, nipple, short	1
1118	206264	VALVE, needle	1
1119	114367	FITTING, tube, qd, 90 degree elbow	1
1120	109544	FITTING, elbow, pipe, male	1
1121	110914	VALVE, button, push	1
1122	100264	SCREW, mach, panhead	4
1123	116514	NUT, regulator mount	1
1124	109193	FITTING, tube, male, elbow	2
1125	16F151	FITTING, elbow, swivel, 3/8 tee, 3/8 npt	1
1126	---	SEALANT, pipe, stainless steel	1
1127	054134	TUBE, nylon, 3/8 in. OD	1.1
1128	517305	TUBE, nylon, 5/32 in. OD	0.7
1129	122056	VALVE, check, brass, 1/4 MBE	1
1130	100840	FITTING, elbow, street	1

--- Not for sale.

**Check Valve (16T481)**

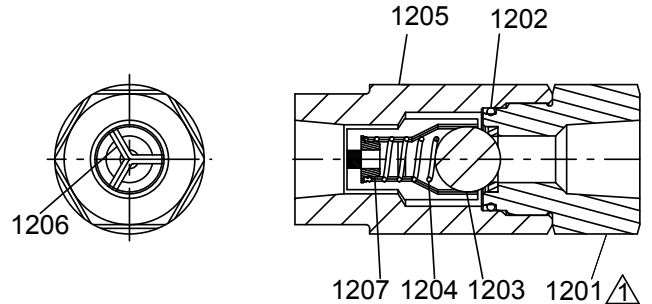
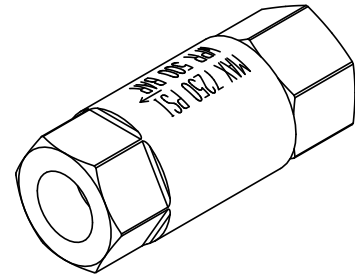

Torque to 75-80 ft-lb (102-108 N•m).

Ref.	Part	Description	Qty.
1201	16T479	NUT, seat	1
1202	102595	PACKING, o-ring	1
1203	102972	BALL, metallic	1
1204	108361	SPRING, compression	1
1205	16T477	HOUSING, ball check	1
1206	181492	GUIDE, ball	3
1207	181535	RETAINER, spring	1

--- Not for sale.

### Flexible Fluid Connection Kit (262820)

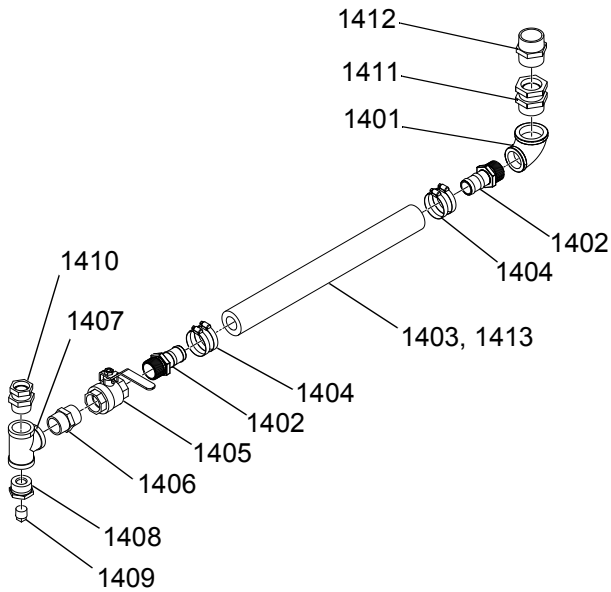

### Accessories

Part	Description	Qty.
17G061	BAG, 100 pack, polyethylene, (see <b>Batch Dispense or Ratio Test</b> in sprayer Setup - Operation manual)	1
24P833	KIT, mix wetted parts, contains one set of spare parts from the mix manifold outlet to the spray tip.	1
24X113	KIT, hot water flush, for hazardous area machines, see form 332073	1
24Y132	KIT, hot water flush, for non-hazardous area machines, see form 332073	1

Ref.	Part	Description	Qty.
1401	120291	PIPE, elbow female	1
1402	125995	FITTING, hose, barbed, 1-1/2 npt	2
1403	126320	HOSE, 1-1/2 ID, 200 psi, 3 ft; for side to side configuration	1
1404	126889	CLAMP, hose	2
1405	121440	VALVE, ball, 1-1/2 npt	1
1406	121441	FITTING, nipple, hex, 1-1/2 npt	1
1407	121443	FITTING, tee, 1-1/2npt	1
1408	101496	BUSHING, pipe	1
1409	104663	PLUG, pipe	1
1410	121445	SWIVEL, reducing, 1-1/2 x 1-1/4	1
1411	121436	FITTING, swivel, male, 2 in.	1
1412	121435	FITTING, nipple, hex, 2 in.	1
1413	17D794	HOSE, 1-1/2 ID, 200 psi, 13 in; for front to back configuration	1

# Dimensions

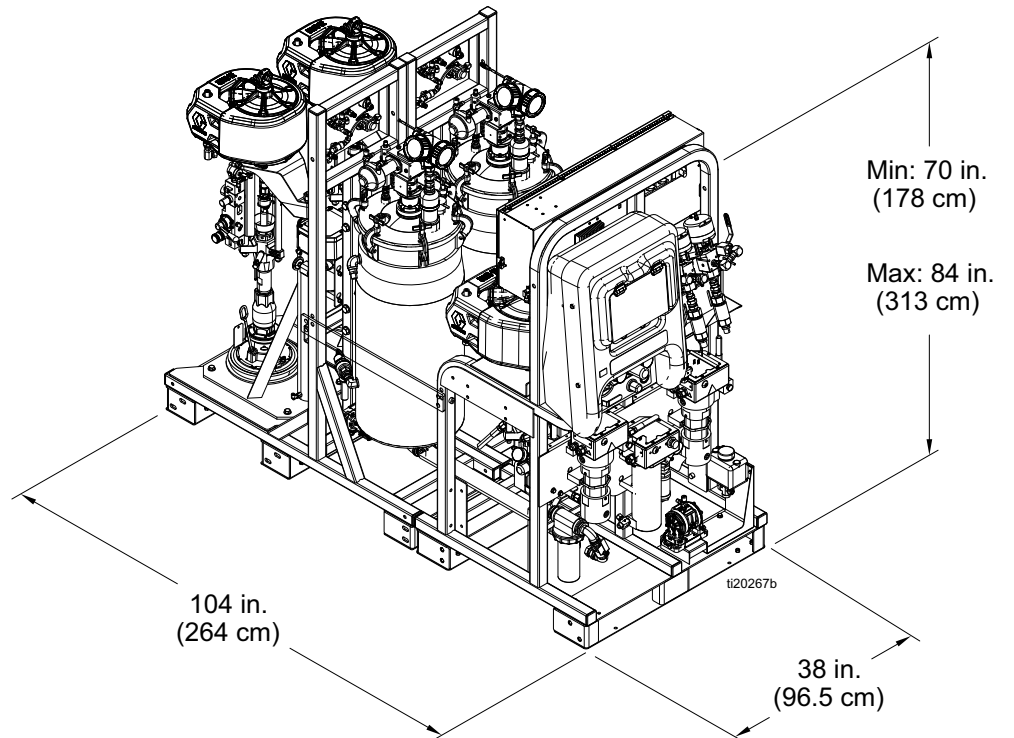
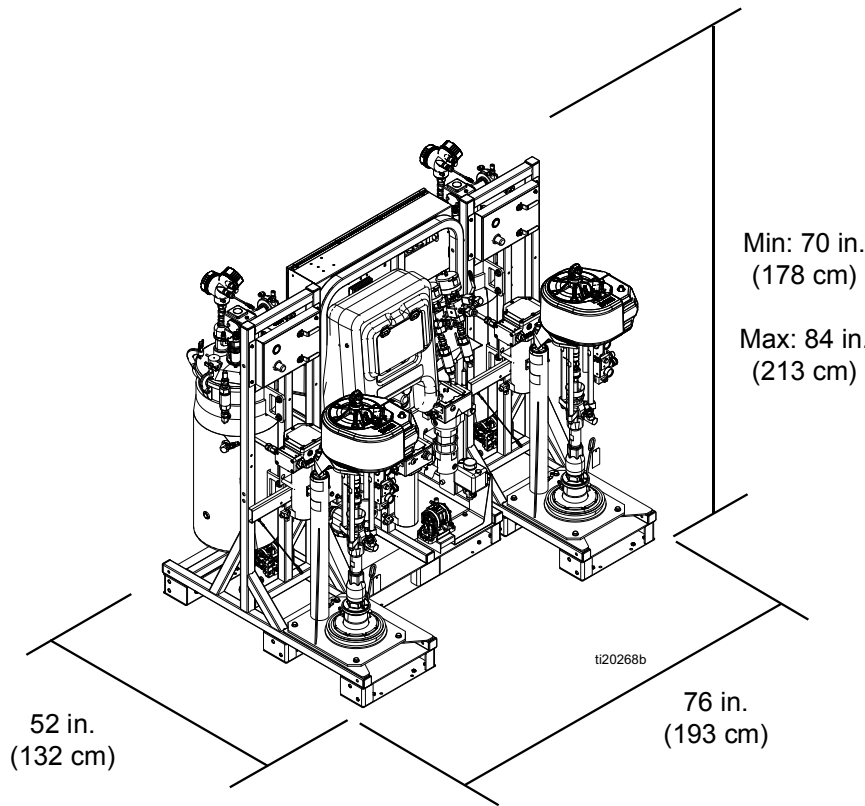

# Technical Specifications

<b>XM PFP</b>		
	<b>US</b>	<b>Metric</b>
Ratio Tolerance Range (before alarm)	+/- 5%	
Maximum Flow Rate (measured with oil)	3 gallons per minute	13.6 liters per minute
Fluid Viscosity Range	Handles mastic materials which are loaded into heated tanks with ram-fed priming piston pumps	
Air Inlet	1 in. npt(f)	
Fluid Inlets	Pail (Feed Pumps)	
Maximum Fluid Working Pressure for A and B Materials	6000 psi	41 MPa, 414 bar
Maximum Fluid Working Pressure for Flushing Fluid	4500 psi	31 MPa, 310 bar
Maximum Fluid Working Pressure for Heating Fluid	100 psi	0.7 MPa, 7 bar
Maximum Fluid Temperature	160°F	70°C
System Inlet Supplied Air Pressure Range	80-150 psi	0.5-1.0 MPa, 5.5-10.3 bar
Maximum Main Pump Air Pressure	100 psi	0.7 MPa, 7 bar
Maximum Feed Pump Air Pressure	65 psi	0.45 MPa, 4.5 bar
Maximum Tank Air Pressure	90 psi	0.6 MPa, 6 bar
Air Filtration	40 micron main filter, 5 micron control air filter	
Ambient Operating Temperature Range	32 to 130 °F	0 to 54 °C
Environmental Conditions Rating	Altitude up to 13,123 ft	Altitude up to 4000 m
System Weight (empty, no fluid)	2175 lb	987 kg
<b>Mix Ratio Range</b>		
262869, 262943, 262898	1.5:1 to 4:1	
24W626, 262945	1:1 to 1.5:1	
<b>Air Consumption</b>		
Minimum	100 scfm	2.8 meter <sup>3</sup> /min
Maximum	250 scfm	7.1 meter <sup>3</sup> /min
Typical Application	125-175 scfm	3.5-5.0 meter <sup>3</sup> /min
<b>Power Requirements</b>		
Voltage (can be set with jumpers)	Option 1: 200-240 VAC, 3 phase DELTA (3 wire plus ground) Option 2: 350-415 VAC, 3 phase WYE (4 wire including neutral plus ground)	
Wattage	18,800 watts (non-hazardous location) 18,900 watts (hazardous location) 22,900 watts (with hazardous location flush water heater) 23,400 watts (with optional non-hazardous flush water heater)	

All written and visual data contained in this document reflects the latest product information available at the time of publication. Graco reserves the right to make changes at any time without notice.

Original instructions. This manual contains English. MM 3A2989

**Graco Headquarters:** Minneapolis

**International Offices:** Belgium, China, Japan, Korea

**GRACO INC. AND SUBSIDIARIES • P.O. BOX 1441 • MINNEAPOLIS MN 55440-1441 • USA**  
Copyright 2021, Graco Inc. All Graco manufacturing locations are registered to ISO 9001.

www.graco.com  
Revision ZAF, October 2025

<b>XM PFP</b>		
	<b>US</b>	<b>Metric</b>
Amps	200-240 VAC, 3-phase models DELTA: 63 Amps per phase full load 350-415 VAC, 3-phase models WYE: 40 Amps per phase full load	

<b>XM PFP</b>		
	<b>US</b>	<b>Metric</b>
<b>Storage</b>		
Maximum Storage Time	5 years	
Storage Maintenance	To maintain original performance, replace soft seals after 5 years of inactivity.	
Ambient Storage Temperature Range	30 to 160 °F	1 to 71 °C
<b>Lifetime</b>		
Lifetime Use	Lifetime varies with use, materials sprayed, storage methods, and maintenance. Life minimum is 25 years.	
Lifetime Use Maintenance	Replace leather packings every five years or less based on use.	
End of Life Disposal	If the sprayer is in a condition that it can no longer operate, the sprayer should be taken out of service and dismantled. Individual parts should be sorted by material and disposed of properly. Key construction materials can be found in the Materials of Construction Section. Electronic components are RoHS compliant and should be disposed of properly.	
<b>Graco Four-Character Date Code</b>		
Example: A18B	Month (first character) A = January, Year (second and third characters) 18 = 2018, Series (fourth character) B = serial control number	
<b>Wetted Parts</b>		
Wetted Parts	Aluminum, ductile iron, leather, nylon, plated carbon steel, polyethylene, PTFE, stainless steel, tungsten carbide, UHMWPE	
<b>Purge Requirements</b> (For hazardous models only. Purge air is filtered to instrumentation quality by filters listed above)		
Minimum Purge Time	3 minutes	
Minimum Purge Flow	4.8 scfm	
Maximum Air Temperature	104° F	40° C
Air Filter	3 micron	
<b>Noise (dBa)</b>		
Sound Pressure *	92.2 dBA at 100 psi	92.2 dBA at 0.7 MPa, 7 bar
	85.8 dBA at 70 psi	85.8 dBA at 0.48 MPa, 4.8 bar
Sound Power **	103.2 dBA at 100 psi	103.2 dBA at 0.7 MPa, 7 bar
	96.8 dBA at 70 psi	96.8 dBA at 0.48 MPa, 4.8 bar
* Sound pressure measured 3.3 feet (1 meter) from equipment.		
** Sound power measured per ISO-9614-2.		

## California Proposition 65

CALIFORNIA RESIDENTS

 **WARNING:** Cancer and reproductive harm – [www.P65warnings.ca.gov](http://www.P65warnings.ca.gov).

# Graco Standard Warranty

Graco warrants all equipment referenced in this document which is manufactured by Graco and bearing its name to be free from defects in material and workmanship on the date of sale to the original purchaser for use. With the exception of any special, extended, or limited warranty published by Graco, Graco will, for a period of twelve months from the date of sale, repair or replace any part of the equipment determined by Graco to be defective. This warranty applies only when the equipment is installed, operated and maintained in accordance with Graco's written recommendations.

This warranty does not cover, and Graco shall not be liable for general wear and tear, or any malfunction, damage or wear caused by faulty installation, misapplication, abrasion, corrosion, inadequate or improper maintenance, negligence, accident, tampering, or substitution of non-Graco component parts. Nor shall Graco be liable for malfunction, damage or wear caused by the incompatibility of Graco equipment with structures, accessories, equipment or materials not supplied by Graco, or the improper design, manufacture, installation, operation or maintenance of structures, accessories, equipment or materials not supplied by Graco.

This warranty is conditioned upon the prepaid return of the equipment claimed to be defective to an authorized Graco distributor for verification of the claimed defect. If the claimed defect is verified, Graco will repair or replace free of charge any defective parts. The equipment will be returned to the original purchaser transportation prepaid. If inspection of the equipment does not disclose any defect in material or workmanship, repairs will be made at a reasonable charge, which charges may include the costs of parts, labor, and transportation.

**THIS WARRANTY IS EXCLUSIVE, AND IS IN LIEU OF ANY OTHER WARRANTIES, EXPRESS OR IMPLIED, INCLUDING BUT NOT LIMITED TO WARRANTY OF MERCHANTABILITY OR WARRANTY OF FITNESS FOR A PARTICULAR PURPOSE.**

Graco's sole obligation and buyer's sole remedy for any breach of warranty shall be as set forth above. The buyer agrees that no other remedy (including, but not limited to, incidental or consequential damages for lost profits, lost sales, injury to person or property, or any other incidental or consequential loss) shall be available. Any action for breach of warranty must be brought within two (2) years of the date of sale.

**GRACO MAKES NO WARRANTY, AND DISCLAIMS ALL IMPLIED WARRANTIES OF MERCHANTABILITY AND FITNESS FOR A PARTICULAR PURPOSE, IN CONNECTION WITH ACCESSORIES, EQUIPMENT, MATERIALS OR COMPONENTS SOLD BUT NOT MANUFACTURED BY GRACO.** These items sold, but not manufactured by Graco (such as electric motors, switches, hose, etc.), are subject to the warranty, if any, of their manufacturer. Graco will provide purchaser with reasonable assistance in making any claim for breach of these warranties.

In no event will Graco be liable for indirect, incidental, special or consequential damages resulting from Graco supplying equipment hereunder, or the furnishing, performance, or use of any products or other goods sold hereto, whether due to a breach of contract, breach of warranty, the negligence of Graco, or otherwise.

## **FOR GRACO CANADA CUSTOMERS**

The Parties acknowledge that they have required that the present document, as well as all documents, notices and legal proceedings entered into, given or instituted pursuant hereto or relating directly or indirectly hereto, be drawn up in English. Les parties reconnaissent avoir convenu que la rédaction du présente document sera en Anglais, ainsi que tous documents, avis et procédures judiciaires exécutés, donnés ou intentés, à la suite de ou en rapport, directement ou indirectement, avec les procédures concernées.

## Graco Information

For the latest information about Graco products, visit [www.graco.com](http://www.graco.com).

For patent information, see [www.graco.com/patents](http://www.graco.com/patents).

**TO PLACE AN ORDER**, contact your Graco distributor or call 1-800-690-2894 to identify the nearest distributor.

*All written and visual data contained in this document reflects the latest product information available at the time of publication.  
Graco reserves the right to make changes at any time without notice.*

Original instructions. This manual contains English. MM 3A2989

**Graco Headquarters:** Minneapolis

**International Offices:** Belgium, China, Japan, Korea

**GRACO INC. AND SUBSIDIARIES • P.O. BOX 1441 • MINNEAPOLIS MN 55440-1441 • USA**  
**Copyright 2021, Graco Inc. All Graco manufacturing locations are registered to ISO 9001.**

[www.graco.com](http://www.graco.com)  
Revision ZAF, October 2025