

# EFP-350 XT Electric Feed Pump

X021719EN

Rev. D

***For transfer and supply of solvent-borne and waterborne coatings.  
Not approved for use in explosive atmospheres or hazardous (classified) locations.  
For professional use only.***

**Models: 2009958, 2009959, 2009960, 2011456**  
350 psi (2.4 MPa, 24.1 bar) Maximum Working Fluid Pressure

See page 3 for model information, including maximum working pressure and approvals.



### **Important Safety Instructions**

Read all warnings and instructions in this manual before using the equipment. Be familiar with the proper control and usage of the equipment. Save these instructions.

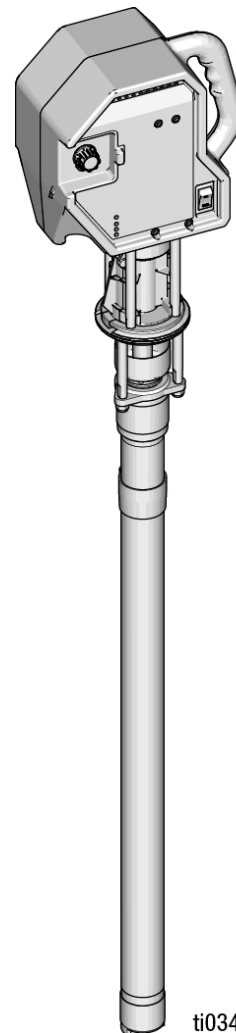



ti03448a



# Contents

|   |           |   |           |
|---|-----------|---|-----------|
| <b>Models</b> .....                                 | <b>3</b>  | <b>Available Models</b> .....                           | <b>35</b> |
| Related Manuals .....                               | 3         | Model 2009958 .....                                     | 35        |
| Translated Manuals .....                            | 3         | Model 2009959 .....                                     | 35        |
| <b>Safety Symbols</b> .....                         | <b>4</b>  | Model 2011456 .....                                     | 35        |
| <b>General Warnings</b> .....                       | <b>5</b>  | Model 2009960 .....                                     | 35        |
| <b>Important Isocyanate (ISO) Information</b> ..... | <b>8</b>  | Available Repair Kits.....                              | 36        |
| Isocyanate Conditions .....                         | 8         | Torque Specifications (for all parts drawings) ..       | 36        |
| Material Self-Ignition .....                        | 9         | <b>Parts, Kits</b> .....                                | <b>37</b> |
| Keep Components A and B Separate .....              | 9         | Kit, Shroud (2010541).....                              | 37        |
| Moisture Sensitivity of Isocyanates .....           | 9         | Kit, Electronics (2010542).....                         | 38        |
| Foam Resins with 245 fa Blowing Agents .....        | 9         | Kit, Encoder (2010553).....                             | 39        |
| Changing Materials .....                            | 9         | Kit, Driver (2010547).....                              | 40        |
| <b>Component Identification</b> .....               | <b>10</b> | Kit, Ball-Screw (2010550).....                          | 41        |
| Driver .....  | 10        | Kit, Driver, Pro-Connect (2010551) .....                | 41        |
| Lower .....   | 11        | Pump Lower Kits* .....                                  | 42        |
| <b>Description of Controls</b> .....                | <b>12</b> | Kit, Lower, Pro-Connect,<br>Parts List (2010552)* ..... | 42        |
| <b>Typical Installations</b> .....                  | <b>13</b> | Kit, Pump Lower, Rebuild,<br>Parts List (25N586)* ..... | 42        |
| <b>Grounding</b> .....                              | <b>15</b> | Kit, Pump Lower, Parts List (2008657)* .....            | 43        |
| <b>Pressure Relief Procedure</b> .....              | <b>16</b> | Kit, Potentiometer (20B425).....                        | 44        |
| <b>Setup</b> .....                                  | <b>17</b> | Kit, ProConnect Clamp (2007115) .....                   | 44        |
| Install the Pump Lower .....                        | 17        | Kit, IEC Field Wireable Plug (26D296) .....             | 44        |
| Install Fluid Supply Hose .....                     | 17        | Kit, IEC EU Plug (814-0339).....                        | 44        |
| Install Driver .....                                | 18        | Kit, IEC North America 120V Plug (17N758) ..            | 44        |
| <b>Operation</b> .....                              | <b>20</b> | Kit, IEC Australia Plug (242005) .....                  | 44        |
| Connect Power .....                                 | 20        | Kit, Power Switch (2010665) .....                       | 44        |
| Priming the Pump .....                              | 20        | Kit, Fan (2010996) .....                                | 44        |
| Controlling and Adjusting the Pump .....            | 21        | <b>Accessories</b> .....                                | <b>45</b> |
| Flushing .....                                      | 22        | <b>Wire Routing</b> .....                               | <b>47</b> |
| Parking/Shutdown .....                              | 23        | Fan .....   | 47        |
| Remove the Driver .....                             | 24        | Encoder Board .....                                     | 47        |
| Remove the Pump Lower .....                         | 25        | Power Switch/Power Port .....                           | 47        |
| Watchdog™ .....                                     | 25        | Ground Choke Board .....                                | 47        |
| <b>Maintenance</b> .....                            | <b>27</b> | Motor .....   | 47        |
| Pump Lower Adjustments* .....                       | 27        | Potentiometer .....                                     | 47        |
| Shutdown and Care of the Pump Lower* .....          | 27        | <b>Product Dimensions</b> .....                         | <b>48</b> |
| Encoder Calibration .....                           | 28        | <b>Technical Specifications</b> .....                   | <b>49</b> |
| Control Knob Calibration .....                      | 29        | <b>Recycling and Disposal</b> .....                     | <b>50</b> |
| <b>Troubleshooting</b> .....                        | <b>30</b> | <b>Graco Standard Warranty</b> .....                    | <b>51</b> |
| <b>ProGuard™ Codes</b> .....                        | <b>34</b> |   |           |

# Models

| Part    | Maximum Working Pressure<br>psi (MPa, bar) | Description  | Model Approvals   | Voltage  | Includes   |
|---------|--|--|---|--|--|
| 2009958 | 350 PSI<br>(2.4 Mpa,<br>24.1 bar)          | Kit, EFP-350 XT, Pump Lower, Bare                  | <br><br> | 100-120 VAC<br>50/60 Hz<br><br>200-240 VAC<br>50/60 Hz | Driver, Pump Lower                                     |
| 2009959 |  | Kit, EFP-350 XT, with Hose and Fittings            |   |  | Driver, Pump Lower, Outlet Hose & Fittings             |
| 2009960 |  | Kit, EFP-350 XT, with Hose, Fittings, and Strainer |   |  | Driver, Pump Lower, Outlet Hose & Fittings, Y Strainer |
| 2011456 |  | Pump, EFP-350 XT with Core-T4 Pump Lower           |   |  | Driver, T4 Pump Lower                                  |

## Related Manuals

| Manual in English | Description              |
|-------------------|--------------------------|
| 3A8598            | ProConnect CS Pump Lower |

## Translated Manuals







Digital versions of translated manuals for this product can be found online at [www.graco.com](http://www.graco.com). Available translations and their respective Graco manual numbers are listed here for reference.

|          |           |
|----------|-----------|
| Chinese  | X021719ZH |
| Dutch    | X021719NL |
| English  | X021719EN |
| French   | X021719FR |
| German   | X021719DE |
| Italian  | X021719IT |
| Japanese | X021719JA |
| Korean   | X021719KO |
| Polish   | X021719PL |
| Spanish  | X021719ES |
| Turkish  | X021719TR |

# Safety Symbols

The following safety symbols appear throughout this manual and on warning labels. Read the table below to understand what each symbol means.

| Symbol  | Meaning                      |
|---|------------------------------|
|    | Burn Hazard                  |
|    | Electric Shock Hazard        |
|    | Equipment Misuse Hazard      |
|   | Fire and Explosion Hazard    |
|  | Moving Parts Hazard          |
|  | Pressurized Equipment Hazard |
|  | Splash Hazard                |

| Symbol  | Meaning                            |
|---|------------------------------------|
|    | Toxic Fluid or Fumes Hazard        |
|    | Eliminate Ignition Sources         |
|    | Follow Pressure Relief Procedure   |
|    | Ground Equipment                   |
|  | Read Manual                        |
|  | Ventilate Work Area                |
|  | Wear Personal Protective Equipment |







## Safety Alert Symbol



This symbol indicates: Attention! Become Alert! Look for this symbol throughout the manual to indicate important safety messages.

# General Warnings

The following warnings apply throughout this manual. Read, understand, and follow the warnings before using this equipment. Failure to follow these warnings can result in serious injury.

|  <h2 style="margin: 0;">WARNING</h2>  |  |
|--|--|
|   | <p><b>TOXIC FLUID OR FUMES HAZARD</b></p> <p>Toxic fluids or fumes can cause serious injury or death if splashed in the eyes or on skin, inhaled or swallowed.</p> <ul style="list-style-type: none"> <li>• Read Safety Data Sheets (SDSs) for handling instructions and to know the specific hazards of the fluids you are using, including the effects of long-term exposure.</li> <li>• When spraying, servicing equipment, or when in the work area, always keep work area well-ventilated and always wear appropriate personal protective equipment. See <b>Personal Protective Equipment</b> warnings in this manual.</li> <li>• Store hazardous fluid in approved containers, and dispose of it according to applicable guidelines.</li> </ul>  |
|   | <p><b>PERSONAL PROTECTIVE EQUIPMENT</b></p> <p>Always wear appropriate personal protective equipment and cover all skin when spraying, servicing equipment, or when in the work area. Protective equipment helps prevent serious injury, including long-term exposure; inhalation of toxic fumes, mists or vapors; allergic reaction; burns; eye injury and hearing loss. This protective equipment includes but is not limited to:</p> <ul style="list-style-type: none"> <li>• A properly fitting respirator, which may include a supplied-air respirator, chemically impermeable gloves, protective clothing and foot coverings as recommended by the fluid manufacturer and local regulatory authority.</li> <li>• Protective eyewear and hearing protection.</li> </ul>   |
| <br> | <p><b>EQUIPMENT MISUSE HAZARD</b></p> <p>Misuse can cause death or serious injury.</p> <ul style="list-style-type: none"> <li>• Do not operate the unit when fatigued or under the influence of drugs or alcohol.</li> <li>• Do not exceed the maximum working pressure or temperature rating of the lowest rated system component. See <b>Technical Specifications</b> in all equipment manuals.</li> <li>• Use fluids and solvents that are compatible with equipment wetted parts. See <b>Technical Specifications</b> in all equipment manuals. Read fluid and solvent manufacturer's warnings. For complete information about your material, request Safety Data Sheets (SDSs) from distributor or retailer.</li> <li>• Do not leave the work area while equipment is energized or under pressure.</li> <li>• Turn off all equipment and follow the <b>Pressure Relief Procedure</b> when equipment is not in use.</li> <li>• Check equipment daily. Repair or replace worn or damaged parts immediately with genuine manufacturer's replacement parts only.</li> <li>• Do not alter or modify equipment. Alterations or modifications may void agency approvals and create safety hazards.</li> <li>• Make sure all equipment is rated and approved for the environment in which you are using it.</li> <li>• Use equipment only for its intended purpose. Call your distributor for information.</li> <li>• Route hoses and cables away from traffic areas, sharp edges, moving parts, and hot surfaces.</li> <li>• Do not lift pressurized equipment.</li> <li>• Do not kink or over bend hoses or use hoses to pull equipment.</li> <li>• Keep children and animals away from work area.</li> <li>• Comply with all applicable safety regulations.</li> </ul> |

# ! WARNING

|  |   |
|--|---|
|    | <p><b>FIRE AND EXPLOSION HAZARD</b></p> <p>Flammable fumes, such as solvent and paint fumes, in <b>work area</b> can ignite or explode. Paint or solvent flowing through the equipment can cause static sparking. To help prevent fire and explosion:</p> <ul style="list-style-type: none"> <li>• Use equipment only in well-ventilated area.</li> <li>• Eliminate all ignition sources, such as pilot lights, cigarettes, portable electric lamps, and plastic drop cloths (potential static sparking).</li> <li>• Ground all equipment in the work area. See <b>Grounding</b> instructions.</li> <li>• Never spray or flush solvent at high pressure.</li> <li>• Keep work area free of debris, including solvent, rags and gasoline.</li> <li>• Do not plug or unplug power cords, or turn power or light switches on or off when flammable fumes are present.</li> <li>• Use only grounded hoses.</li> <li>• Hold gun firmly to side of grounded pail when triggering into pail. Do not use pail liners unless they are anti-static or conductive.</li> <li>• <b>Stop operation immediately</b> if static sparking occurs or you feel a shock. Do not use equipment until you identify and correct the problem.</li> <li>• Keep a working fire extinguisher in the work area.</li> </ul> |
|   | <p><b>MOVING PARTS HAZARD</b></p> <p>Moving parts can pinch, cut or amputate fingers and other body parts.</p> <ul style="list-style-type: none"> <li>• Keep clear of moving parts.</li> <li>• Do not operate equipment with protective guards or covers removed.</li> <li>• Equipment can start without warning. Before checking, moving, or servicing equipment, follow the <b>Pressure Relief Procedure</b> and disconnect all power sources.</li> </ul>   |
|  | <p><b>PRESSURIZED EQUIPMENT HAZARD</b></p> <p>Fluid from the equipment, leaks, or ruptured components can splash in the eyes or on skin and cause serious injury.</p> <ul style="list-style-type: none"> <li>• Follow the <b>Pressure Relief Procedure</b> when you stop spraying/dispensing and before cleaning, checking, or servicing equipment.</li> <li>• Tighten all fluid connections before operating the equipment.</li> <li>• Check hoses, tubes, and couplings daily. Replace worn or damaged parts immediately.</li> </ul>  |

# **WARNING**



**ELECTRIC SHOCK HAZARD**

This equipment must be grounded. Improper grounding, setup, or usage of the system can cause electric shock.



- Turn off and disconnect power cord before servicing equipment.
- Connect only to grounded electrical outlets.
- Use only 3-wire extension cords.
- Ensure ground prongs are intact on power and extension cords.
- Do not expose to rain. Store indoors.
- Wait five minutes after disconnecting power cord before servicing.
- Only use an authorized service center to replace a damaged power cord.



**BURN HAZARD**

Equipment surfaces and fluid that is heated can become very hot during operation. To avoid severe burns:

- Do not touch hot fluid or equipment.

# Important Isocyanate (ISO) Information

Isocyanates (ISO) are catalysts used in two component materials.

## Isocyanate Conditions





Spraying or dispensing fluids that contain isocyanates creates potentially harmful mists, vapors, and atomized particulates.



- Read and understand the fluid manufacturer’s warnings and Safety Data Sheets (SDSs) to know specific hazards and precautions related to isocyanates.
- Use of isocyanates involves potentially hazardous procedures. Do not spray with this equipment unless you are trained, qualified, and have read and understood the information in this manual and in the fluid manufacturer’s application instructions and SDSs.
- Use of incorrectly maintained or mis-adjusted equipment may result in improperly cured material, which could cause off gassing and offensive odors. Equipment must be carefully maintained and adjusted according to instructions in the manual.
- To prevent inhalation of isocyanate mists, vapors and atomized particulates, everyone in the work area must wear appropriate respiratory protection. Always wear a properly fitting respirator, which may include a supplied-air respirator. Ventilate the work area according to instructions in the fluid manufacturer’s SDSs.
- Avoid all skin contact with isocyanates. Everyone in the work area must wear chemically impermeable gloves, protective clothing and foot coverings as recommended by the fluid manufacturer and local regulatory authority. Follow all fluid manufacturer recommendations, including those regarding handling of contaminated clothing. After spraying, wash hands and face before eating or drinking.
- Hazard from exposure to isocyanates continues after spraying. Anyone without appropriate personal protective equipment must stay out of the work area during application and after application for the time period specified by the fluid manufacturer. Generally this time period is at least 24 hours.
- Warn others who may enter work area of hazard from exposure to isocyanates. Follow the recommendations of the fluid manufacturer and local regulatory authority. Posting a placard such as the following outside the work area is recommended:



## Material Self-Ignition

|  |   |  |  |  |
|--|---|--|--|--|
|   |  |  |  |  |
| Some materials may become self-igniting if applied too thick. Read material manufacturer's warnings and Safety Data Sheets (SDSs). |   |  |  |  |

## Keep Components A and B Separate

|  |   |   |  |  |
|--|---|---|--|--|
|   |  |  |  |  |
| Cross-contamination can result in cured material in fluid lines which could cause serious injury or damage equipment. To prevent cross-contamination:  |   |   |  |  |
| <ul style="list-style-type: none"> <li>• <b>Never</b> interchange component A and component B wetted parts.</li> <li>• Never use solvent on one side if it has been contaminated from the other side.</li> </ul> |   |   |  |  |

## Moisture Sensitivity of Isocyanates

Exposure to moisture (such as humidity) will cause ISO to partially cure, forming small, hard, abrasive crystals that become suspended in the fluid. Eventually a film will form on the surface and the ISO will begin to gel, increasing in viscosity.

| NOTICE   |  |  |  |  |
|--|--|--|--|--|
| Partially cured ISO will reduce performance and the life of all wetted parts.  |  |  |  |  |
| <ul style="list-style-type: none"> <li>• Always use a sealed container with a desiccant dryer in the vent, or a nitrogen atmosphere. <b>Never</b> store ISO in an open container.</li> <li>• Use only moisture-proof hoses compatible with ISO.</li> <li>• Never use reclaimed solvents, which may contain moisture. Always keep solvent containers closed when not in use.</li> <li>• Always lubricate threaded parts with an appropriate lubricant when reassembling.</li> </ul> |  |  |  |  |

**NOTE:** The amount of film formation and rate of crystallization varies depending on the blend of ISO, the humidity, and the temperature.

## Foam Resins with 245 fa Blowing Agents

Some foam blowing agents will froth at temperatures above 90 °F (33 °C) when not under pressure, especially if agitated. To reduce frothing, minimize preheating in a circulation system.

## Changing Materials

| NOTICE  |  |  |  |  |
|---|--|--|--|--|
| Changing the material types used in your equipment requires special attention to avoid equipment damage and downtime.   |  |  |  |  |
| <ul style="list-style-type: none"> <li>• When changing materials, flush the equipment multiple times to ensure it is thoroughly clean.</li> <li>• Check with your material manufacturer for chemical compatibility.</li> <li>• When changing between epoxies and urethanes or polyureas, disassemble and clean all fluid components and change hoses. Epoxies often have amines on the B (hardener) side. Polyureas often have amines on the B (resin) side.</li> </ul> |  |  |  |  |

# Component Identification

## Driver

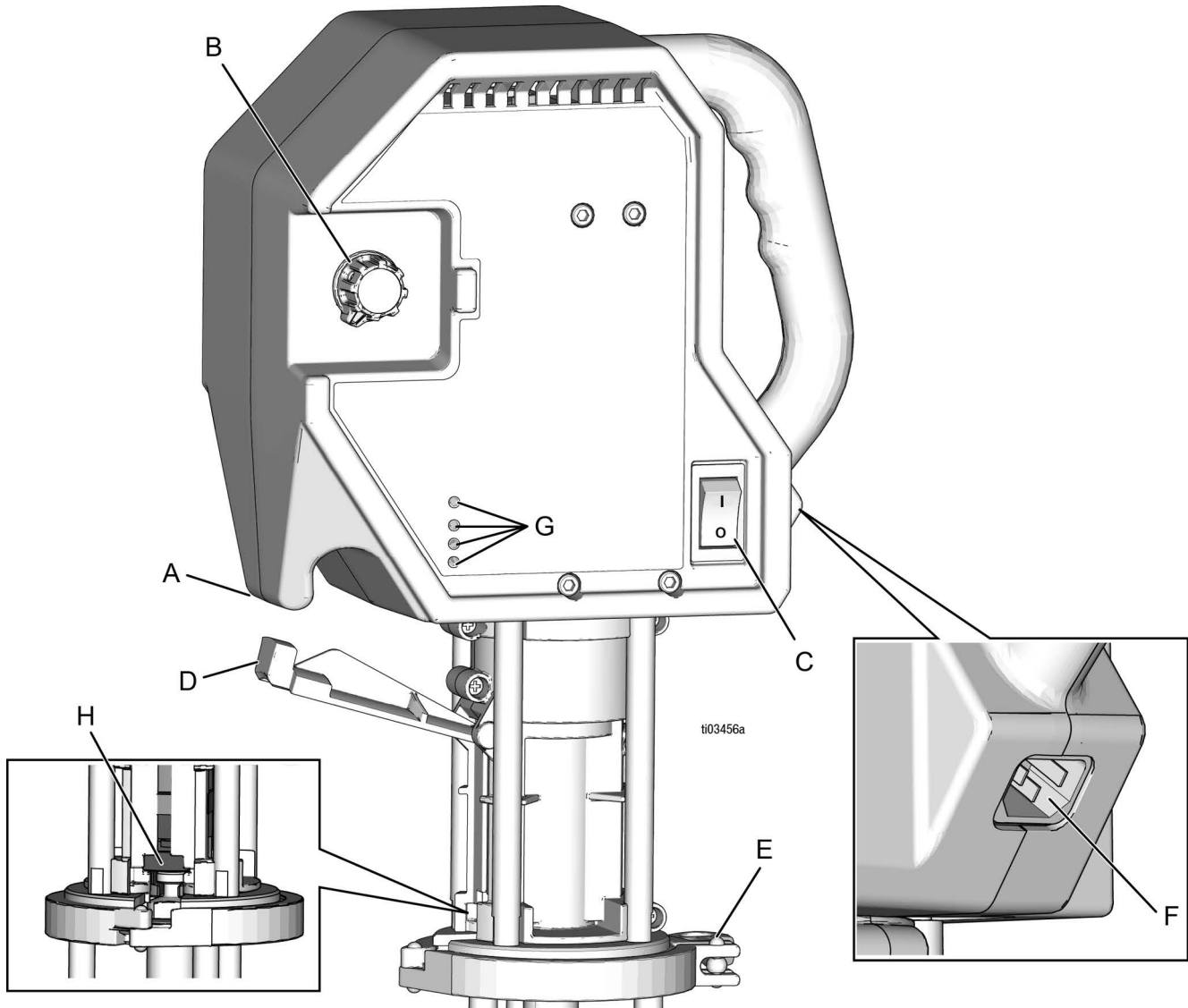

| Ref. | Description  |
|------|--------------|
| A    | Barrel Hook  |
| B    | Control Knob |
| C    | Power Switch |

| Ref. | Description             |
|------|-------------------------|
| D    | ProConnect® Access Door |
| E    | ProConnect Clamp        |
| F    | Power Port              |
| G    | Status Lights           |
| H    | ProConnect Coupler      |

# Lower

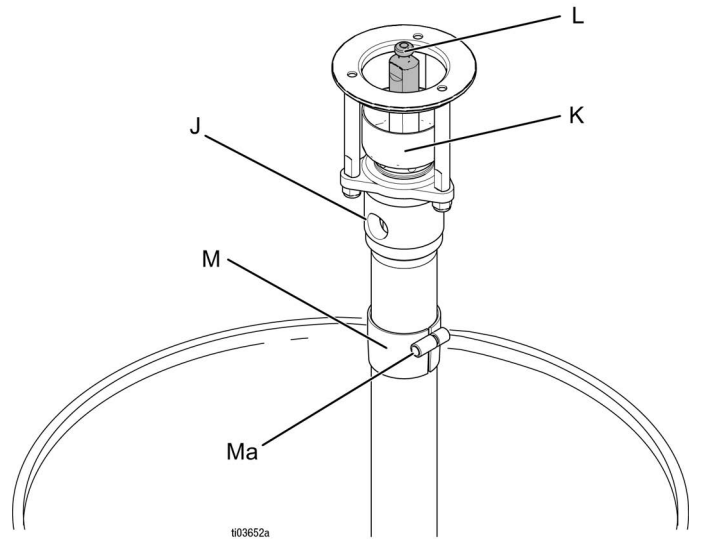
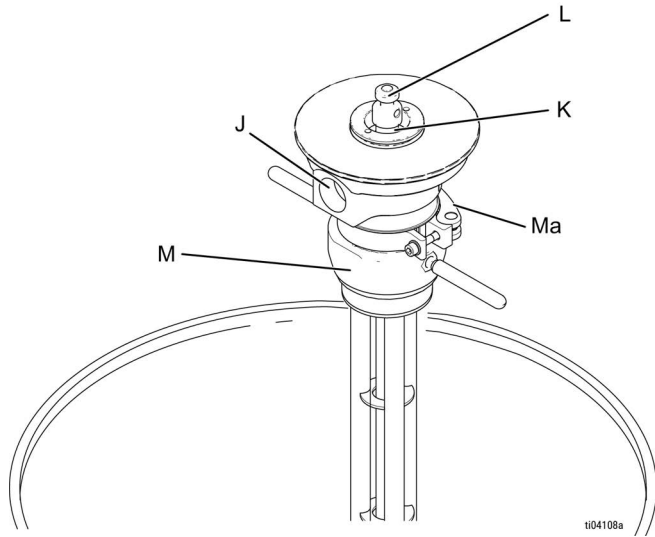

**Ref. Description**

- J Fluid Outlet Part (3/4 NPT (F))
- K Packing Nut/Wet-Cup
- L ProConnect Pump Rod
- M 2 in. NPT Bung Adapter
- Ma Bung Adapter Clamp

# Description of Controls

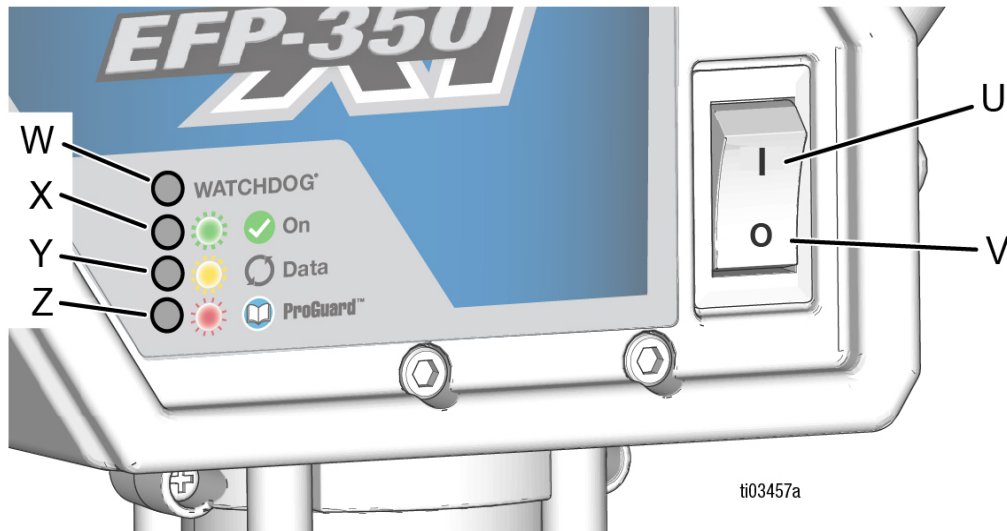
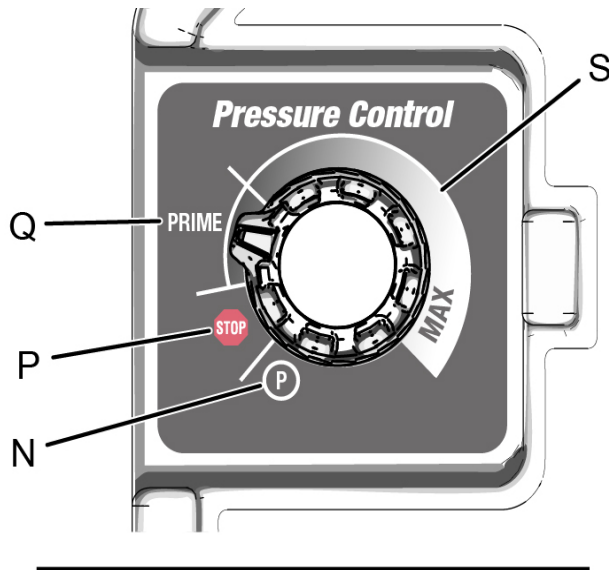

ti03457a

| Ref. | Description   |
|------|---------------|
| N    | PARK MODE     |
| P    | STOP          |
| Q    | PRIME MODE    |
| S    | PRESSURE MODE |

| Ref. | Description                   |
|------|-------------------------------|
| U    | Power ON                      |
| V    | Power OFF                     |
| W    | Watchdog™                     |
| X    | Power Status                  |
| Y    | Data Communication (not used) |
| Z    | ProGuard™                     |

# Typical Installations

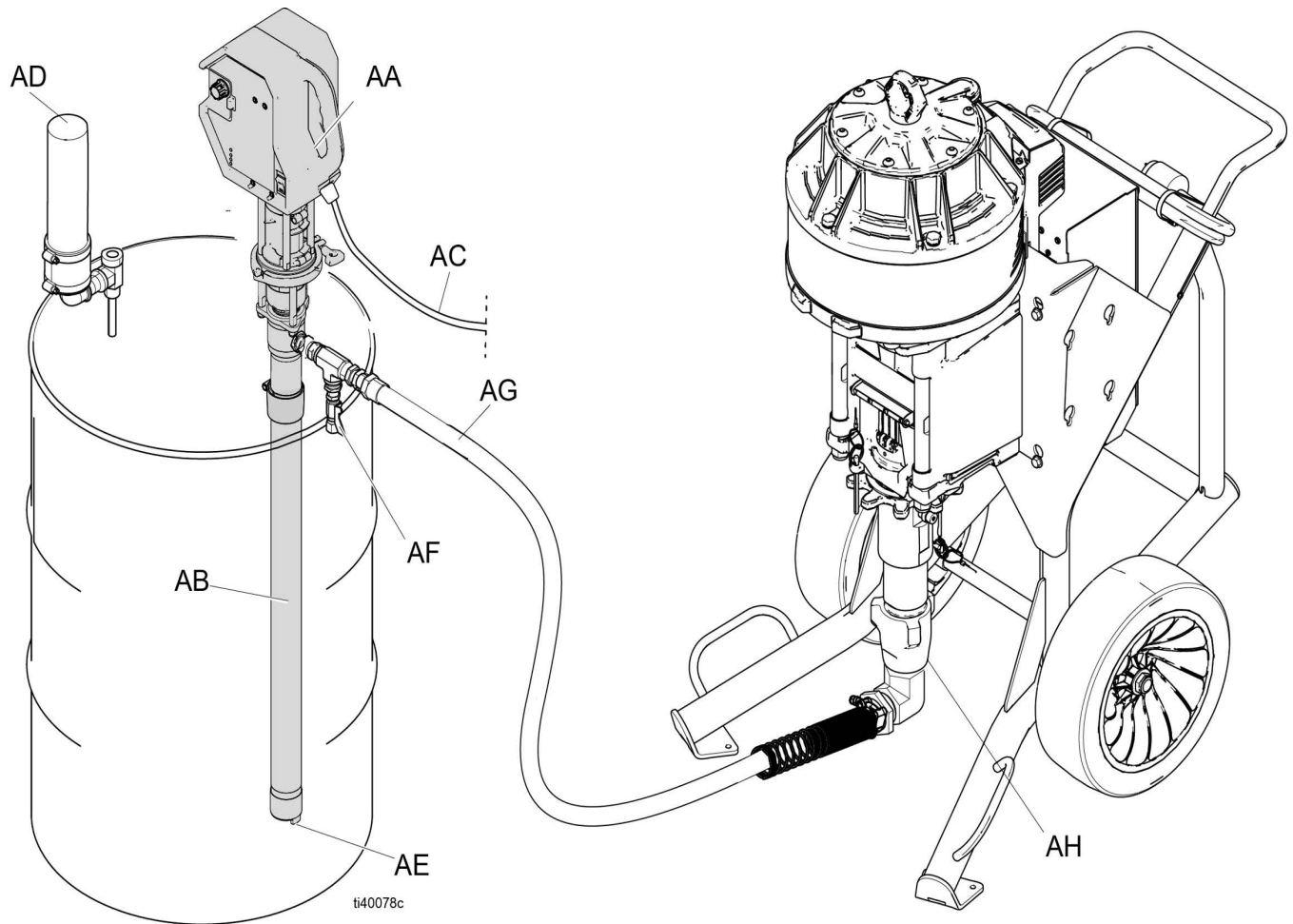

ti40078c

**Ref. Description**

- AA Driver
- AB Pump Lower
- AC Power Cable
- AD\* Desiccant Dryer
- AE Pump Fluid Inlet
- AF\* Fluid Drain Valve (required)
- AG† Fluid Supply Hose
- AH\* Sprayer Pump

\* Sold separately

† Included in certain product configurations, or sold separately.

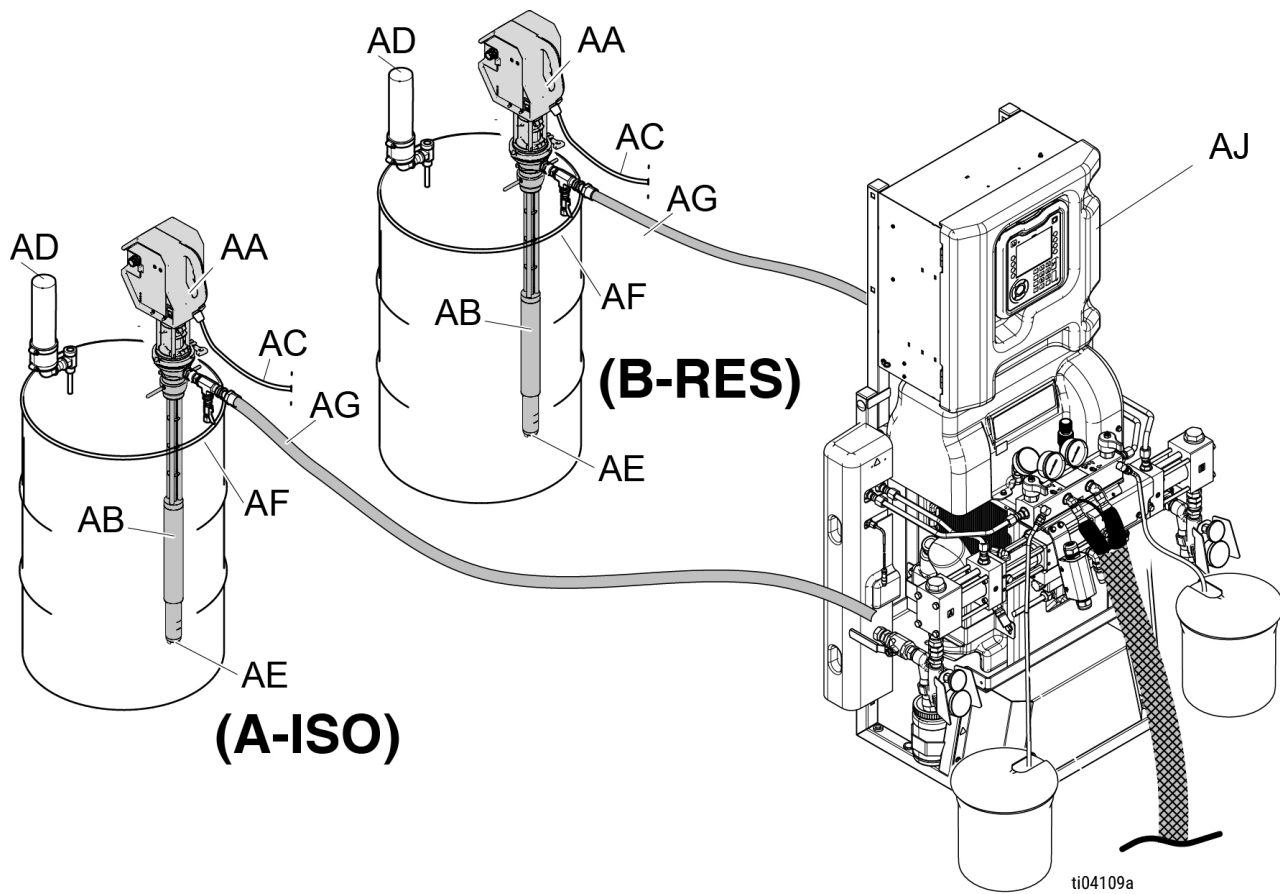

**Ref. Description**

- AA Driver
- AB Pump Lower
- AC Power Cable
- AD\* Desiccant Dryer
- AE Pump Fluid Inlet
- AF\* Fluid Drain Valve (required)
- AG† Fluid Supply Hose
- AJ\* Reactor Proportioner

\* Sold separately

† Included in certain product configurations, or sold separately.

# Grounding

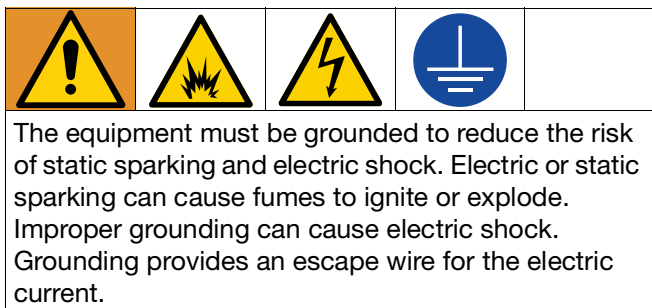

**Transfer Pump:** Grounded through the power cord.

**Fluid hoses:** use only electrically conductive hoses.

**Spray gun / Dispense valve:** ground through connection to a properly grounded fluid hose and pump.

**Fluid supply container:** follow local codes and regulations.

**Object being sprayed:** follow local codes and regulations.

**Solvent pails used when flushing:** follow local code. Use only conductive metal pails, placed on a grounded surface. Do not place the pail on a non-conductive surface, such as paper or cardboard, which interrupts grounding continuity.

**To maintain grounding continuity when flushing or relieving pressure:** hold metal part of the spray gun/dispense valve firmly to the side of a grounded metal pail, then trigger the gun/valve.

**Work area:** ground the object being sprayed, fluid supply container, and all other equipment in the work area.

# Pressure Relief Procedure



Follow the Pressure Relief Procedure whenever you see this symbol.



This equipment stays pressurized until pressure is manually relieved. To help prevent serious injury from pressurized fluid, such as splashing fluid and moving parts, follow the Pressure Relief Procedure when you stop spraying and before cleaning, checking, or servicing the equipment.

1. Engage the trigger lock on the spray gun/dispense valve.
2. Turn Control Knob (B) to STOP and turn Power Switch (C) **OFF**.

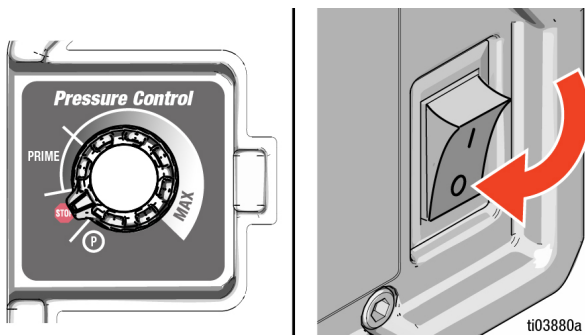

3. Disengage trigger lock on the spray gun/dispense valve.
4. Hold a metal part of the spray gun/dispense valve firmly to the side of a grounded metal pail, and trigger the spray gun/dispense valve to relieve pressure.
5. Engage the trigger lock on the spray gun/dispense valve.

6. Open the Fluid Drain Valve (AF) (required in your system), having a container ready to catch the material.

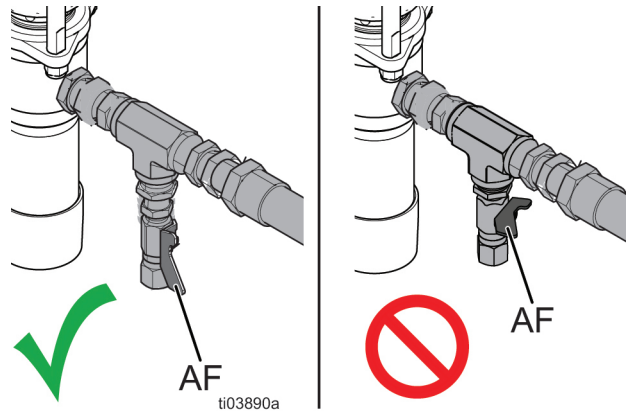

7. Leave the Fluid Drain Valve (AF) open until you are ready to spray/dispense again. If you suspect the spray tip or hose is clogged, or that pressure has not been fully relieved:
  - a. Using a wrench, **VERY SLOWLY** loosen the tip guard retaining nut or the hose end coupling to relieve pressure gradually.
  - b. Using a wrench, loosen the nut or the coupling completely.
  - c. Clear the obstruction in the hose or tip.

# Setup

## Install the Pump Lower

1. Slowly place the Pump Lower (AB) in drum through the drum bunghole.

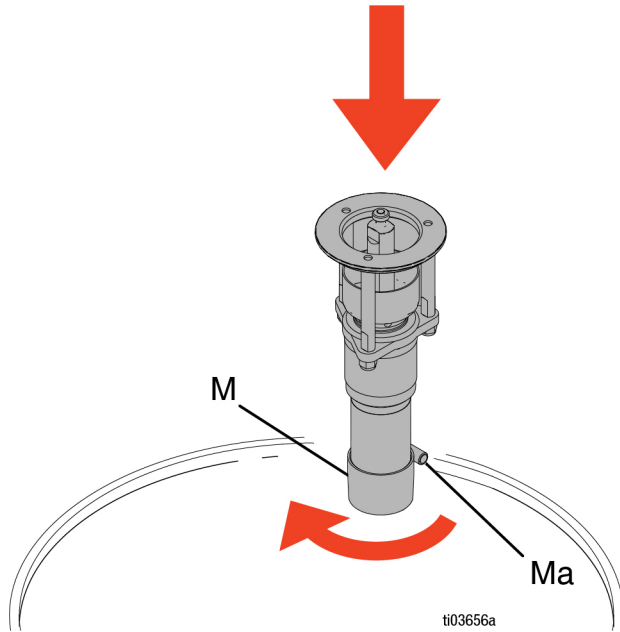

2. Screw the Bung Adapter (M) securely into the bunghole on the drum until the pump fluid inlet (AE) is a 1/2 in. (13 mm) from the bottom of drum, and tighten clamp (Ma) on the Bung Adapter (M) to hold the Pump Lower (AB) in place.
3. If using moisture sensitive material, install Desiccant Dryer kit(s) (AD). See your desiccant kit manual for instructions.

## Install Fluid Supply Hose





A Fluid Drain Valve (AF) is required in the system to help reduce the risk of serious injury, including splashing fluid in the eyes or on the skin, and injury from moving parts when adjusting or repairing the pump.

The Fluid Drain Valve (AF) helps relieve pressure in the displacement pump, hose, and gun when shutting off the pump. Actuating the gun to relieve pressure may not be sufficient, especially if there is a clog in the hose or the spray gun.

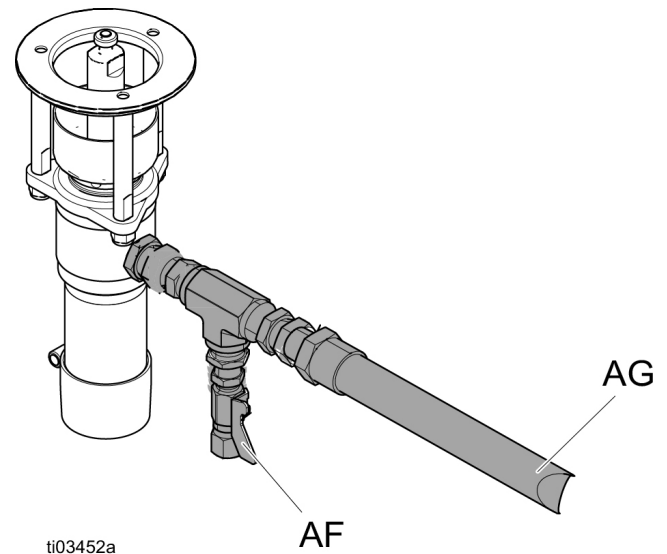
1. Apply thread sealant to all non-swivel connections and install the outlet fitting (not supplied on all models) and required Fluid Drain Valve (AF) to the pump lower outlet.
2. Install Fluid Supply Hose (AG).



## Install Driver

|   |   |   |  |  |
|---|---|---|--|--|
|    |  |  |  |  |
| <p>Never use the power cord to lift or adjust the pump. Lifting or adjusting the pump with the power cord can damage the cord and cause injury from electric shock.</p> |   |   |  |  |

1. Turn the Driver Power Switch (C) **OFF**.

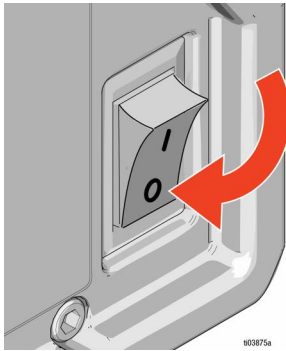

2. If the Pump Lower (AB) has not been parked, set the Pump Rod (L) height to 0.84 in. (21 mm) so that it can couple to the Driver ProConnect Coupler (H).

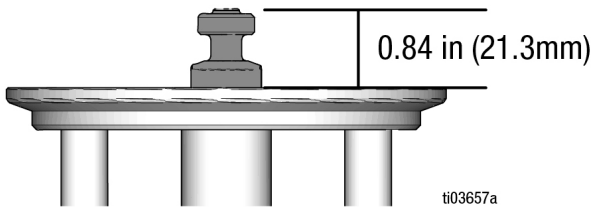

3. Open the ProConnect Access Door (D) and verify Driver (AA) is parked. See **Parking/Shutdown**, page 23 for instructions on how to park the Driver (AA).

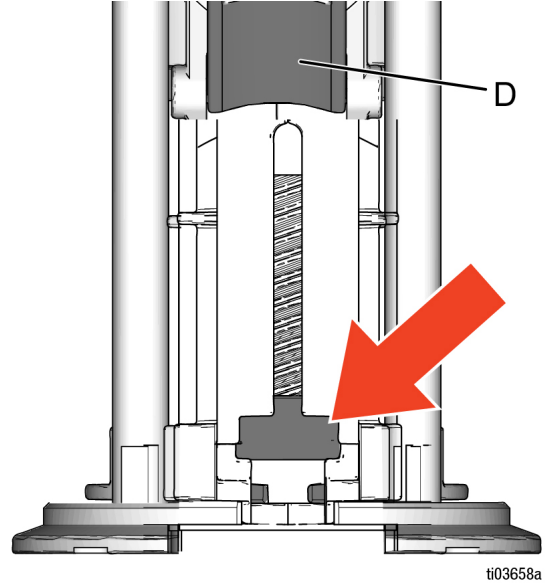

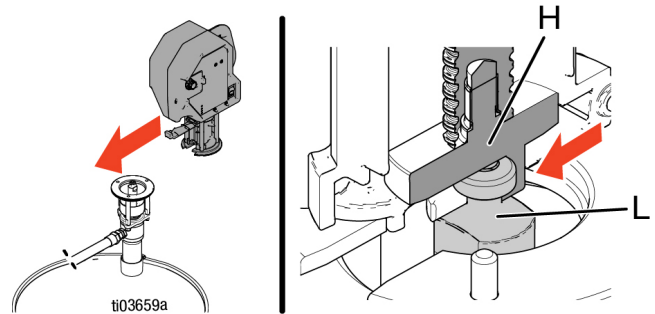

4. Slide the Driver (AA) onto the Pump Lower (AB). The notch in the ProConnect Coupler (H) should align with the button head on ProConnect Pump Rod (L).

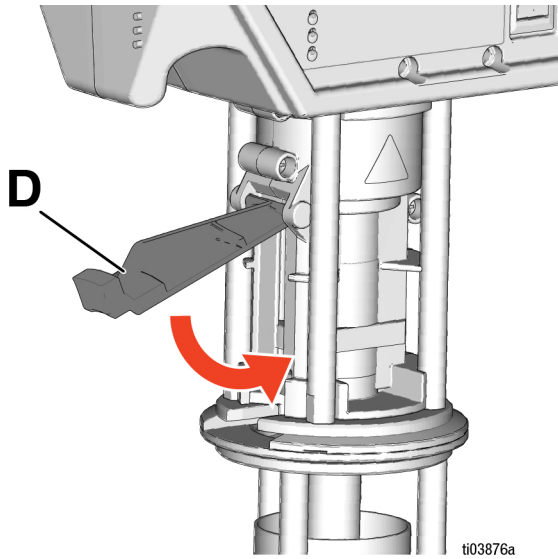

5. Close the ProConnect Access Door (D).



|  |  |  |  |  |
|--|--|--|--|--|
|                                        |  |  |  |  |
| <p>Always keep the ProConnect Access Door (D) closed and secured with the clamp to prevent injury from moving parts.</p> |  |  |  |  |

6. Install the ProConnect Clamp (E). Use a screwdriver or rod to tighten the wing nut one half-turn past finger tight.

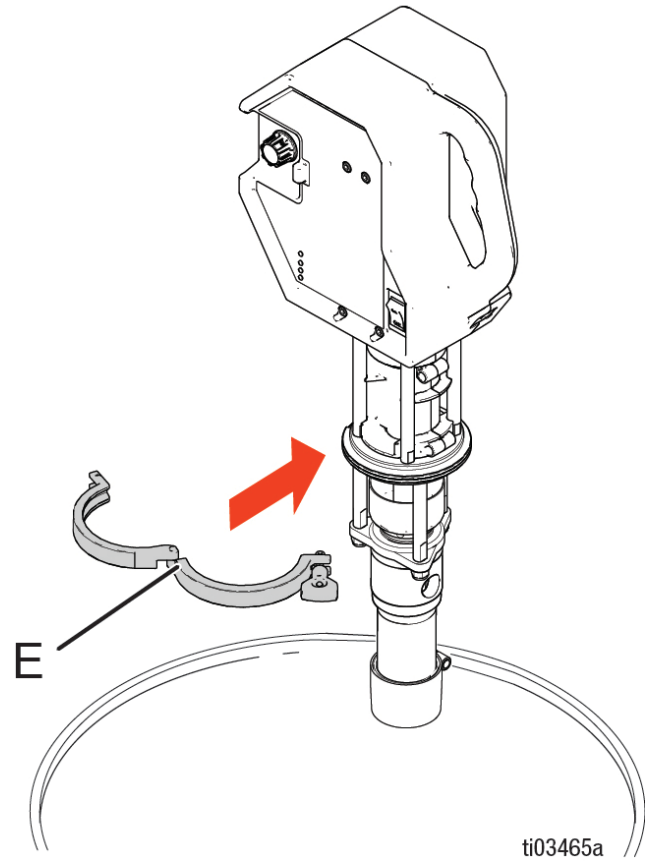

# Operation

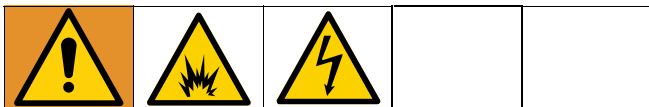

Improperly installed or connected equipment may result in serious injury from fire, explosion, or electric shock. Follow local codes and regulations.

## Connect Power

Plug the power cable into Power Port (F). Connect to a 100-120VAC, 50/60 Hz or 200-240VAC, 50/60 Hz power source with a circuit breaker not exceeding 20A.

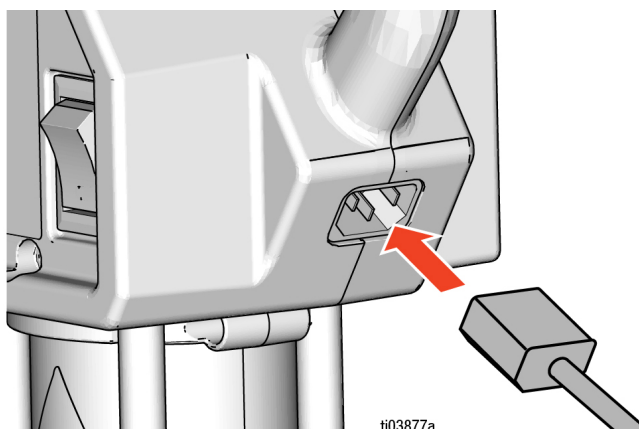

**NOTICE**  
Do not operate if the Pump Lower (AB) and Driver (AA) are not properly coupled together or without the ProConnect Clamp (E) installed and tightened. Damage to the equipment could occur.

## Flush Before Using Equipment



To avoid fire and explosion, always ground equipment and waste container. To avoid static sparking and injury from splashing, always flush at the lowest possible pressure.

The equipment was tested with lightweight oil, which is left in the fluid passages to protect parts. To avoid contaminating your fluid with oil, flush the equipment with a compatible solvent before using the equipment.

See **Flushing**, page 22. If the pump is being used to supply a circulating system, allow the solvent to circulate until the pump is thoroughly flushed.

## Priming the Pump

1. See **Setup**, page 17.
2. Turn the power **ON** by using the Power Switch (C) on the Driver (AA).

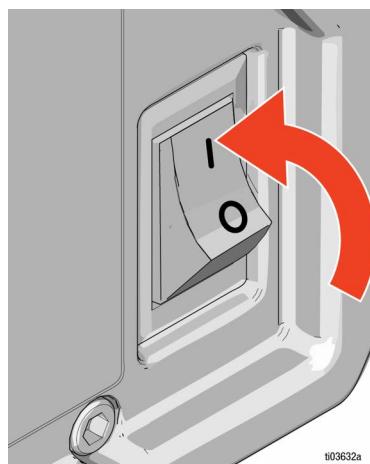

**NOTE: Pressure Relief Procedure**, page 16, is recommended prior to power-up. Residual fluid pressure in the system can interrupt the startup sequence.

3. Verify the Fluid Drain Valve (AF) is closed.

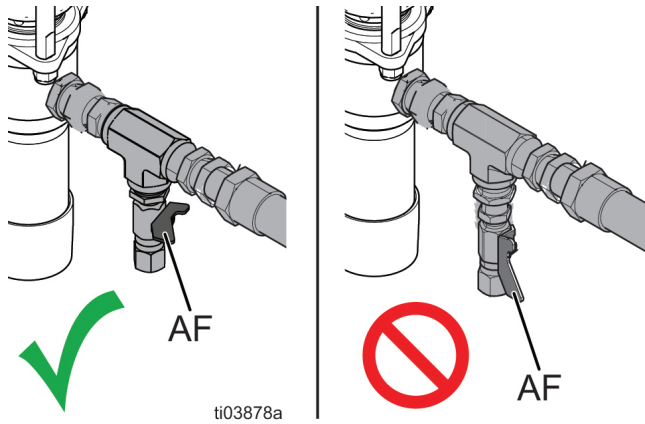

4. Hold a metal part of the spray gun/dispense valve firmly to the side of a grounded metal pail and hold the trigger open. Slowly move the Control Knob (B) on the Driver (AA) to PRIME MODE. If the Electric Feed Pump is being used to supply fluid to the inlet of another pump or spray machine, initiate the priming sequence on that machine at this time.

**NOTE:** Anytime the Power Switch (C) is cycled, the Driver (AA) will run an automated calibration sequence. During this sequence, the pump may move slower than anticipated for several strokes. Once the calibration sequence is complete, the pump will increase to the intended speed.

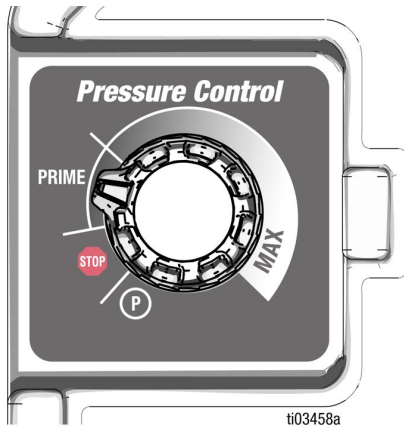

5. Cycle the pump slowly until all air is pushed out and the pump and hoses are fully primed. The speed of the pump while in PRIME MODE will be the slowest with the Control Knob (B) in the furthest counter-clockwise position and faster as the Knob (B) is turned clockwise through PRIME.
6. Release the gun/valve trigger and engage the trigger lock. The pump should stall against pressure when the trigger is released.

## Controlling and Adjusting the Pump

1. Turn the power **ON** by using the Power Switch (C) on the Driver (AA).

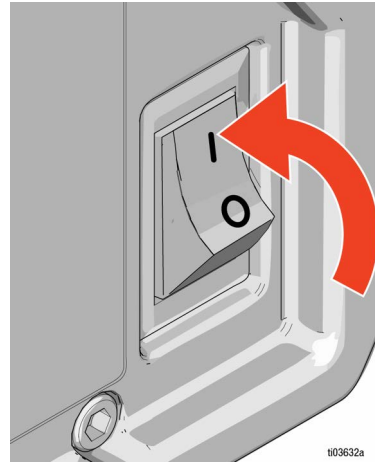

**NOTE: Pressure Relief Procedure**, page 16, is recommended prior to power-up. Residual fluid pressure in the system can interrupt the startup sequence.

2. Perform **Priming the Pump**, page 20.
3. Set the Control Knob (B) to the lowest pressure setting in PRESSURE MODE (S).

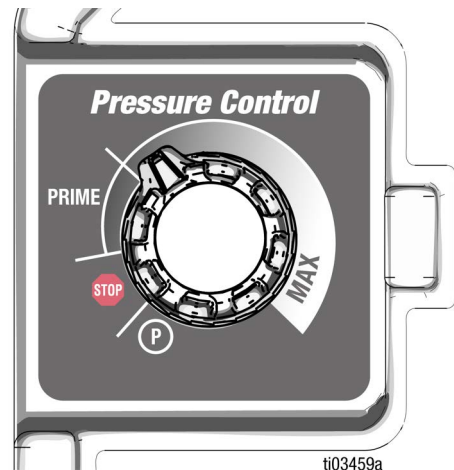

4. With the pump and hoses primed, the pump will start and stop as the gun/valve is opened and closed. In a circulating system, the pump will run intermittently and will speed up and slow down as the system demands until the Control Knob (B) is placed in the STOP (P) position, PARK MODE (N), or the Power Switch (C) is turned **OFF**.

- Slowly increase the system pressure to the desired level by rotating the Control Knob (B) clockwise in the PRESSURE MODE (S) region. Always use the lowest pressure necessary to get the desired results. Higher pressure than necessary, can negatively effect performance and cause premature wear of the pump components.

**NOTICE**

Never allow the pump to run dry of fluid being pumped. A dry pump will quickly accelerate to a high speed, possibly damaging itself. If the pump accelerates quickly or is running too fast, stop immediately and check the fluid supply. If the supply container is empty and air has been pumped into the lines, refill the container and prime the pump and the lines with fluid, or flush and leave it filled with a compatible solvent. Be sure to eliminate all air from the fluid system.

**NOTE:** This system is equipped with Watchdog™ to help protect the pump in the scenario described in the previous section. See **Watchdog™**, page 25, for more information on enabling this feature.

## Flushing



To avoid fire and explosion, always ground equipment and waste container. To avoid static sparking and injury from splashing, always flush at the lowest possible pressure.

**Solvent pails when flushing:** Follow local code. Use only conductive metal pails, placed on a grounded surface. Do not place the pail on a non-conductive surface, such as paper or cardboard, which interrupts grounding continuity.

**To maintain grounding continuity when flushing or relieving pressure:** Hold a metal part of the spray gun or dispense valve firmly to the side of a grounded metal pail, then start the pump.

Flush with a fluid that is compatible with the fluid being pumped. Check with the fluid manufacturer or supplier for recommended flushing fluids and flushing frequency.

- Follow the **Pressure Relief Procedure**, page 16.
- If flushing through a spray gun, remove the nozzle/spray tip.
- Hold a metal part of the spray gun/dispense valve firmly to the side of a grounded metal pail.
- To start the pump, turn the Power Switch (C) **ON** and move the Control Knob (B) to PRIME MODE (Q). Always use the lowest possible fluid pressure when flushing.

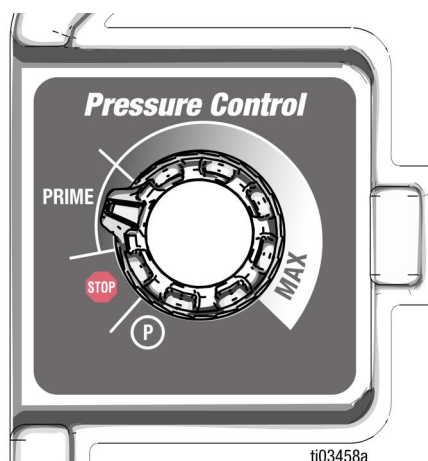

ti03458a

5. Trigger the gun/dispense valve.
6. Once any/all air has been purged from the system, increase flow to speed flushing by turning the Control Knob (B) clockwise through PRIME MODE (Q).
7. Flush the system until flushing solvent is clear at the system outlet.
8. Follow the **Pressure Relief Procedure**, page 16.
9. If using a nozzle/spray tip, clean it separately before re-installing.

**NOTE:** A minimum of five gallons (19 liters) of solvent is recommended for flushing.

## Parking/Shutdown

1. Turn the power **ON** by using the Power Switch (C) on the Driver (AA).



2. Follow the **Pressure Relief Procedure**, page 16.

3. Park the pump by moving the Control Knob (B) to PARK (N). Pressure must be relieved within three seconds for Driver (AA) to move to park position. If pressure is not relieved in that time, cycle the Control Knob (B) in and out of PARK MODE to re-initialize the park sequence.

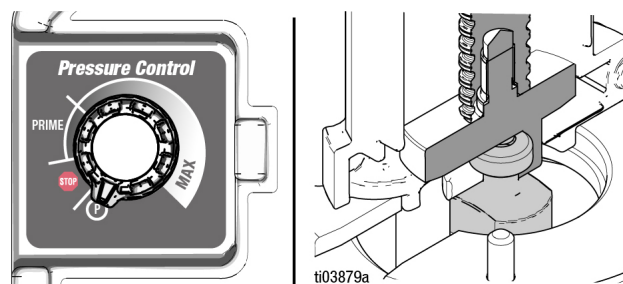

**NOTE:** If Driver (AA) failed to park this could be due to reaching maximum fluid pressure of the system. Hold a metal part of the spray gun/dispense valve to the side of a grounded metal pail and trigger the gun/dispense valve.

**NOTE:** Parking the pump increases seal life on the pump and increases the ease of aligning the ProConnect features on the transfer pump. The pump will automatically park at the bottom of the stroke when in PARK (N) mode.

4. Turn Control Knob (B) to Stop and turn Power Switch (C) to **OFF**.

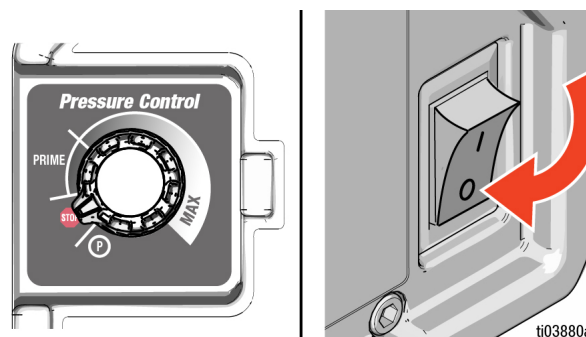

5. Follow the **Pressure Relief Procedure**, page 16.
6. Disconnect the driver power supply.

## Remove the Driver

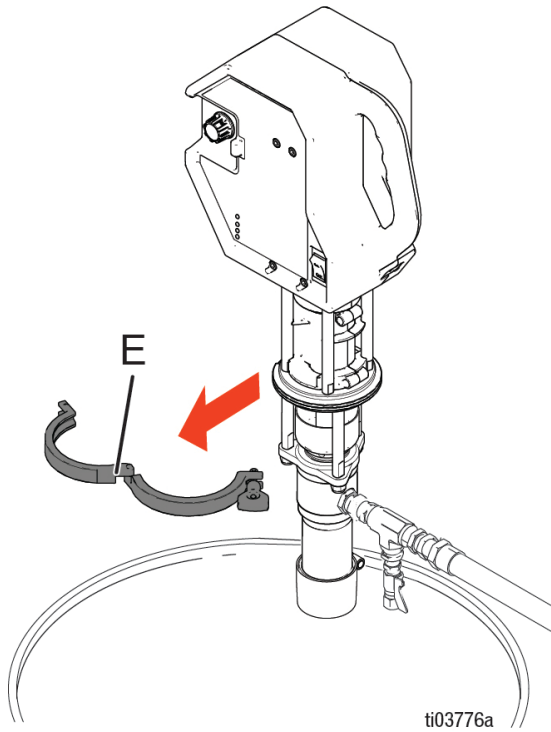

1. Follow the **Pressure Relief Procedure**, page 16.
2. Perform **Parking/Shutdown**, page 23.
3. Remove the ProConnect Clamp (E) by loosening the wing nut.

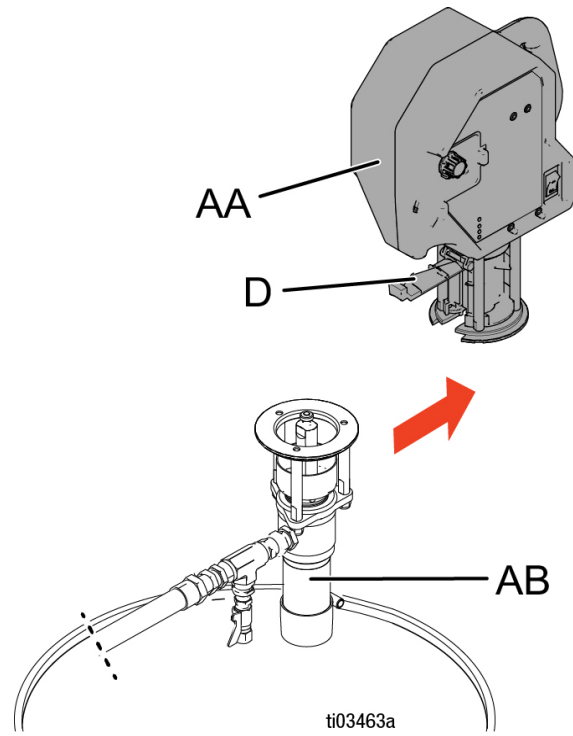

4. Open the ProConnect Access Door (D).

5. Slide the Driver (AA) away from the Pump Lower (AB) and remove the Driver (AA).



|   |  |  |  |  |  |
|---|--|--|--|--|--|
|    |  |  |  |  |  |
| <p>Never use the power cord to lift or adjust the driver. Lifting or adjusting the pump with the power cord can damage it and cause injury from electric shock.</p> |  |  |  |  |  |

## Remove the Pump Lower

1. Follow the **Pressure Relief Procedure**, page 16.
2. Follow steps under **Remove the Driver**, page 24.
3. Loosen the Bung Adapter Clamp (Ma) and unthread Bung Adapter (M).
4. Carefully lift the Pump Lower (AB) up and out of the drum.

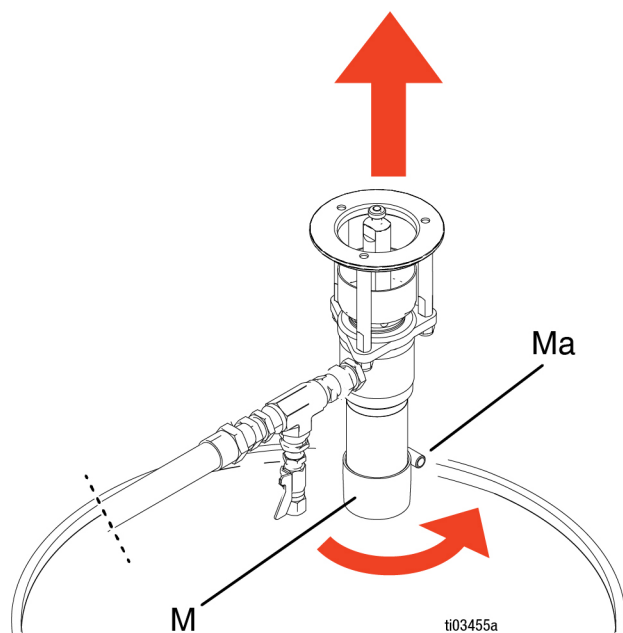

## Watchdog™

In order to protect the pump lower seals from unnecessary wear, the Watchdog Pump Protection System automatically shuts down the pump when material runs out or the pump lower is damaged. The Watchdog feature is only active while in PRESSURE MODE (S). When the Watchdog feature is active, a Watchdog event can only be triggered if the system has been in PRESSURE MODE (S) for at least 30 seconds. If a Watchdog event has been triggered, the Watchdog status light will flash. To reactivate the pump, confirm adequate material is present and move the Control Knob (B) into PRIME MODE (Q). Once primed, move the Control Knob (B) back into PRESSURE MODE (S) and continue normal operation.

Follow the steps below to enable the Watchdog feature:

1. Turn the Power Switch (C) **ON**.

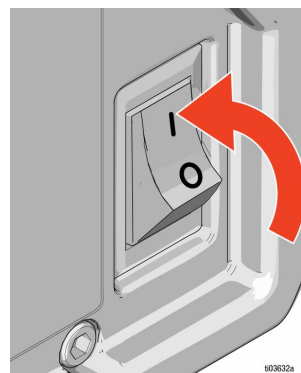

2. Within the first 10 seconds of the Power Switch (C) being turned **ON**, cycle the Control Knob (B) between STOP (P) and PARK (N) six times.

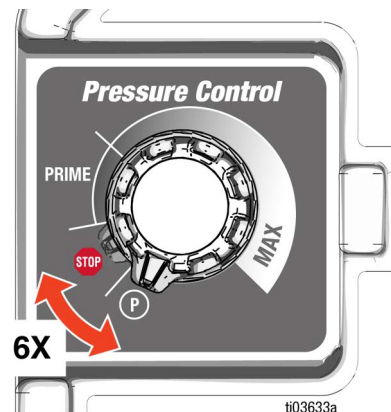

## Operation

- When the sequence is complete, the red Watchdog status light will illuminate solid red. This indicates Watchdog is enabled.

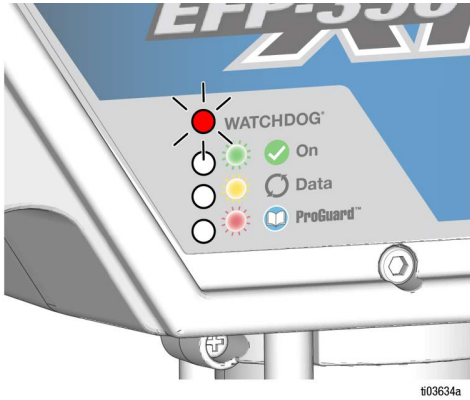

- If the sequence was entered incorrectly, toggle the Power Switch (C) and repeat step 2.
- To disable Watchdog repeat the previous sequence of steps (1-2). When this sequence is complete, the red Watchdog status light will turn off. This indicates Watchdog is disabled.

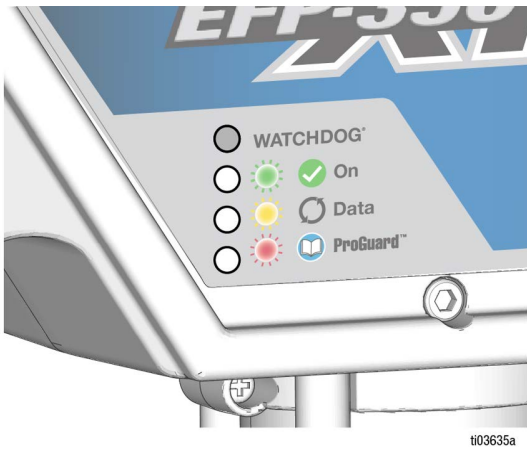

- If the sequence was entered incorrectly, toggle the Power Switch (C) and repeat step 2.

# Maintenance

## Pump Lower Adjustments\*

\* Excludes model 2011456, see manual 3A8598

The piston and intake ball travel are set for medium viscosity fluids from the factory. To adjust the travels, first perform the **Pressure Relief Procedure**, page 16, and unplug the power cord.

Remove the ball stop pin (916) from the intake valve seat (917). Move the pin to a higher set of holes to increase the Intake Ball (915) travel for thicker fluids, or to a lower set of holes to decrease the Intake Ball (915) travel for thinner fluids.

To adjust the Piston Ball (911) travel, loosen the Locknut (909) and turn the Piston (910) counterclockwise to increase the ball travel and clockwise to decrease the ball travel. For medium viscosity fluid, the ball travel should be 0.19 in. (4.8 mm).

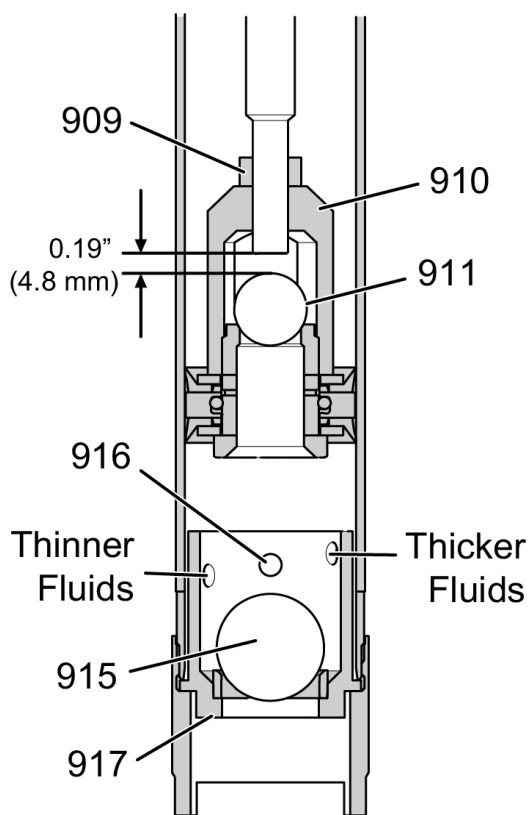

## Shutdown and Care of the Pump Lower\*

\* Excludes model 2011456, see manual 3A8598

For overnight shutdown, always perform the **Pressure Relief Procedure**, page 16, and always perform the steps listed under **Parking/Shutdown**, page 23. Parking the pump at the bottom of the stroke prevents the fluid from drying on the exposed displacement rod and damaging the throat packings.

If you are pumping fluid which dries, hardens, or sets-up, flush the system with a compatible solvent as often as necessary to prevent buildup of the fluid in the pump or hoses, see **Flushing**, page 22.

### NOTICE

Never leave the pump or hoses filled with water or air. To help prevent corrosion, flush the water and all air out of the system and leave it filled with mineral spirits or an oil-based solvent. Be sure to perform the **Pressure Relief Procedure**, page 16, after flushing.

Keep the Packing Nut/Wet-Cup (K) one half filled with Graco Throat Seal Liquid (TSL). Adjust the Packing Nut/Wet-Cup (K) weekly so it is just tight enough to prevent leakage; do not over tighten. Follow the **Pressure Relief Procedure**, page 16, before adjusting the Packing Nut/Wet-Cup (K). Then use a spanner wrench or a 0.25 in. (6.3 mm) diameter rod to tighten the Packing Nut/Wet-Cup (K).

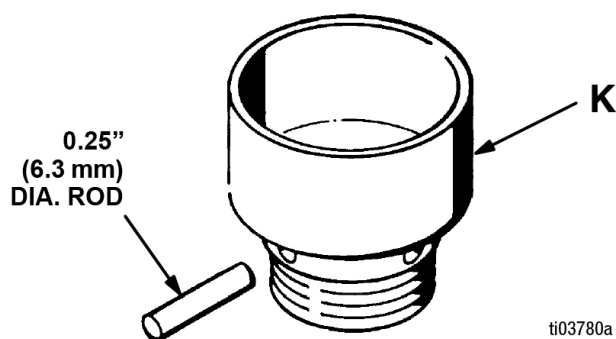



**NOTE:** Over tightening the Packing Nut/Wet-Cup (K) can cause premature wear and reduce system performance.

## Encoder Calibration

The encoder is calibrated prior to leaving the factory and is ready to use. However, if the encoder is replaced, the motor control board is replaced, or the motor is disconnected from the control board, an encoder calibration may be required to operate again.

To perform an encoder calibration, follow the steps listed:

1. Remove the Driver (AA) from the Pump Lower (AB), see **Remove the Driver**, page 24, and set on a flat surface.

|   |   |  |  |  |
|---|---|--|--|--|
|    |  |  |  |  |
| <p>To reduce risk of injury from moving parts and pinching, keep ProConnect Access Door (D) closed and leave on flat surface while operating Driver (AA).</p> |   |  |  |  |

**NOTE:** For an encoder calibration to be successful, Driver (AA) must be able to move freely.

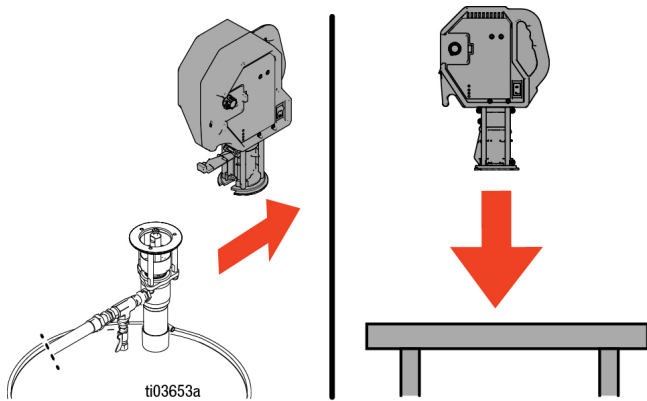

2. With the Driver (AA) completely powered down (green status light off), turn the Power Switch (C) **ON**.

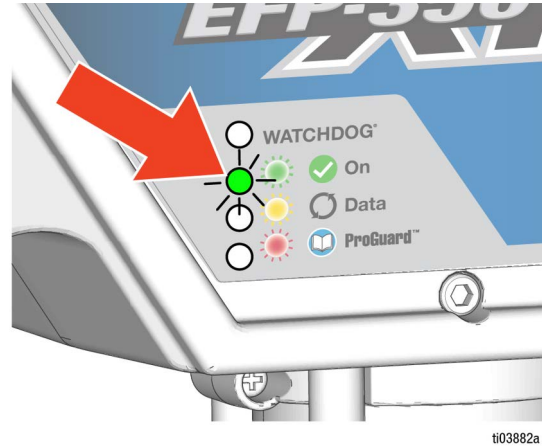

3. Within the first 10 seconds of the Driver (AA) being powered on, cycle the Control Knob (B) between STOP (P) and PRIME (Q) 12 times.

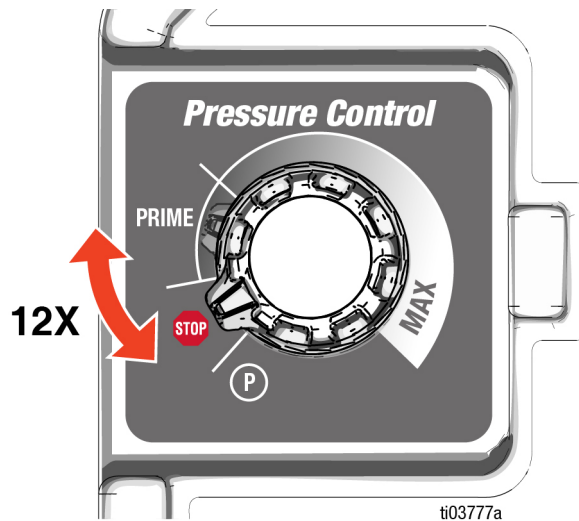

4. When the sequence is complete, the encoder calibration will initiate, and the Driver (AA) will begin to cycle slowly.

- The encoder calibration is complete when the Driver (AA) comes to a stop. If there is an issue with the encoder calibration, the ProGuard status light will flash. Determine the cause of the error (see **ProGuard™ Codes**, page 34) and repeat the steps 2-4 to attempt an encoder calibration again.

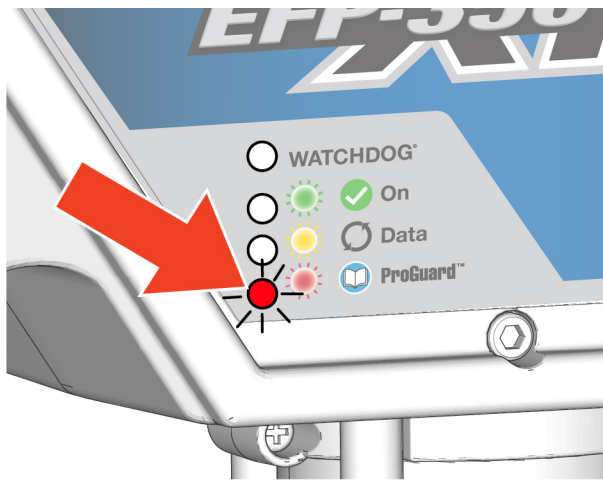

ti03883a

- After a successful encoder calibration, the pump can be returned to normal operation. Place the Driver (AA) in PARK MODE and re-install onto the Pump Lower (AB). See, **Install Driver**, page 18.

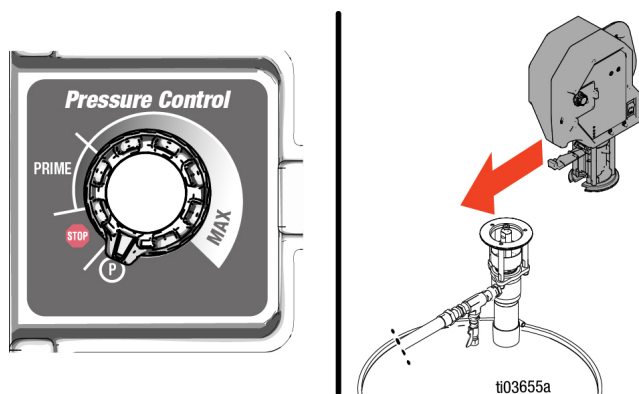

ti03655a

## Control Knob Calibration

The Control Knob (B) is calibrated prior to leaving the factory and is ready to use. However, if the control knob or the motor control board is replaced, a knob calibration may be required for the pump to operate in the indicated mode.

To calibrate the Control Knob (B), perform the following steps:

- With the Driver (AA) completely powered down (green status light off), place the Control Knob (B) in the STOP (P) position.

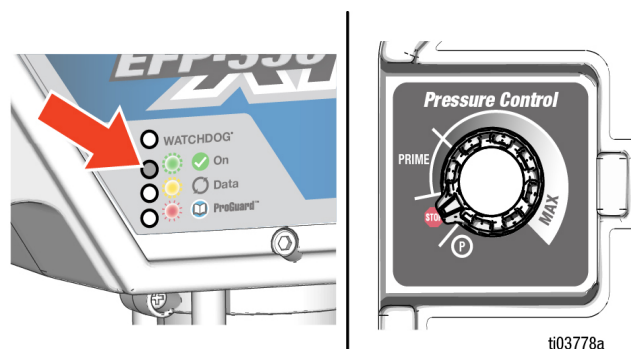

ti03778a

- Rapidly cycle the Power Switch (C) from **OFF** to **ON** 12 times within 10 seconds.

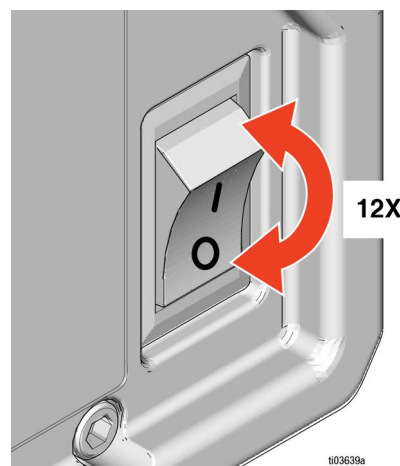

ti03639a

- When the sequence is complete, the knob calibration will initiate.
- If the Control Knob (B) was not in the STOP (P) position or the sequence was performed incorrectly, repeat the steps above to attempt a new knob calibration.

# Troubleshooting



Follow **Pressure Relief Procedure**, page 16, and unplug the power cord before checking or repairing the equipment.

**NOTE:** Check all possible problems and causes before disassembling the equipment.

| Problem                                | Cause  | Solution  |
|--|--|---|
| Driver does not power ON.              | No power.  | Turn ON/OFF Switch <b>ON</b> .  |
|  |  | Plug in Power Cord. Check for loose connection.   |
|  |  | Check incoming power. Check extension cord, check GFI, check breaker.                                       |
|  | Loose internal wires.  | Check internal wiring connections.  |
|  | Failed electrical components.  | Replace electrical components.  |
| Driver is powered on but does not run. | Residual pressure in system.   | Perform <b>Pressure Relief Procedure</b> , page 16.   |
|  | Error has occurred (ProGuard status light is flashing).                              | See <b>ProGuard™ Codes</b> , page 34.   |
|  | Contamination or clog inside pump lower, fluid hose, or downstream valve/components. | Clean/flush pump lower, fluid valve, and downstream components.   |
|  | Driver not properly attached to lower.   | Verify button head on pump rod is in the adapter on the motor.  |
| Watchdog status light blinking.        | Exhausted fluid supply.  | Refill the fluid supply and reprime the pump. (Turning control knob to PRIME MODE resets Watchdog feature). |

| Problem  | Cause  | Solution  |
|--|--|---|
| Output pressure is lower than anticipated.                 | Packing nut/wet cup (K) too tight (if applicable).   | Adjust packing nut/wet cup torque. See <b>Shutdown and Care of the Pump Lower*</b> , page 27.   |
|  | Thick material.  | Condition material per manufacturers specifications.  |
|  | Contamination or clog inside pump lower, fluid hose, or downstream valve/components.   | Clean/flush pump lower, fluid valve, and downstream components.   |
|  | Strainer is clogged (if applicable).   | Remove and clean, then reinstall.   |
|  | Worn intake/foot valve or piston valve inside pump lower.  | Rebuild pump lower.   |
|  | Control board/motor are over heating which software is cutting back pressure for protection.   | Clean inlet and outlet vents.   |
|  |  | If fan is not running, check fan wire connection and/or replace fan.  |
|  | Reduce ambient temperature.  |   |
| Large pressure drop in hose with high viscosity materials. | Reduce overall length of hose. Use larger diameter hose. Precondition material to recommended temperature per manufacturers specification. |   |
| Ball screw contamination.                                  | Clean ball screw/re-lubricate or replace ball screw assembly.  |   |
| Not dispensing material during prime.                      | Air in pump lower or hose.   | Cycle pump lower as slowly as possible and purge air/material through spray gun/dispense valve by following <b>Priming the Pump</b> , page 20.                      |
|  | Packing nut/wet cup too tight (if applicable).   | Adjust packing nut/wet cup torque. See <b>Shutdown and Care of the Pump Lower*</b> , page 27.   |
|  | Thick material.  | Condition material per manufacturers recommendation.  |
|  | Contamination or clog inside pump lower, fluid hose, or downstream valve/components.   | Clean/flush pump lower, fluid valve, and downstream components.   |
|  | Control knob requires calibration.   | See <b>Control Knob Calibration</b> , page 29.  |
|  | Control knob (potentiometer) damaged or loose connection.  | Check wire connection or replace potentiometer.   |
| Driver does not park.                                      | System is pressurized.   | Open downstream drain valve and/or open spray gun/dispense valve then move control knob to stop and back to park. Driver has three seconds to park before stopping. |

| Problem  | Cause  | Solution  |
|--|--|---|
| Driver does not install onto pump lower.                     | Driver not in park position.   | Park the driver, see <b>Parking/Shutdown</b> , page 23.   |
|  | Pump lower rod height not in correct position.                                       | Park the pump lower, see <b>Install Driver</b> , page 18.   |
|  | Sticky when installing and removing.   | Apply grease to ProConnect components.  |
|  | Damaged ProConnect components.   | Replace components.   |
| The pump operates, but the output is low on both strokes.    | Contamination or clog inside pump lower, fluid hose, or downstream valve/components. | Clean/flush pump lower, fluid valve, and downstream components.   |
|  | Packing nut/wet cup too tight (if applicable).                                       | Adjust packing nut/wet cup torque. See <b>Shutdown and Care of the Pump Lower*</b> , page 27.           |
|  | Exhausted fluid supply.  | Refill the fluid supply and reprime the pump.   |
|  | Worn intake valve or piston valve inside pump lower.                                 | Rebuild pump lower.   |
|  | Damaged ball screw assembly.   | Replace ball screw assembly.  |
|  | Incorrect check ball height.   | Set check ball to proper height based on fluid viscosity. See <b>Pump Lower Adjustments*</b> , page 27. |
| The pump operates, but the output is low on the down stroke. | Thick material.  | Condition material per manufacturers specifications.  |
|  | Intake valve not seating correctly.  | Remove intake valve and clean with compatible solvent.  |
|  | Worn or damaged pump lower seats.  | Install pump lower seal repair kit.   |
|  | Incorrect check ball height.   | Set check ball to proper height based on fluid viscosity. See <b>Pump Lower Adjustments*</b> , page 27. |
| The pump operates, but the output is low on the upstroke.    | Thick material.  | Condition material per manufacturers specifications.  |
|  | Piston valve not seating correctly.  | Remove piston valve and clean with compatible solvent.  |
|  | Worn or damaged pump lower seals.  | Install pump lower seal repair kit.   |
|  | Incorrect check ball height (if applicable).   | Set check ball to proper height based on fluid viscosity. See <b>Pump Lower Adjustments*</b> , page 27. |
| Pump lower getting hot during operation.                     | Incorrect check ball height (if applicable).   | Set check ball to proper height based on fluid viscosity. See <b>Pump Lower Adjustments*</b> , page 27. |

| Problem  | Cause   | Solution   |
|--|---|--|
| Erratic or accelerated operation.                                | Exhausted fluid supply.   | Refill the fluid supply and reprime the pump.  |
|  | Air in pump lower or hose.  | Cycle pump lower as slowly as possible and purge air/material through spray gun/dispense valve by following <b>Priming the Pump</b> , page 20. |
|  | Incorrect check ball height (if applicable).                            | Set check ball to proper height based on fluid viscosity. See <b>Pump Lower Adjustments*</b> , page 27.  |
|  | Held open or worn intake valve/piston valve.                            | Clear or service the pump lower.   |
| Pump slowly moves after fluid shutoff in the down stroke.        | Worn or contaminated intake valve.                                      | Clean or service the pump lower.   |
|  | Worn or damaged throat seals.   | Clean or service the pump lower.   |
|  | Leak in the system and system is attempting to maintain stall pressure. | Check all fittings for a loose connection/leak.  |
| Pump moves slowly after fluid shutoff in the upstroke.           | Worn or contaminated piston valve.                                      | Clean or service the pump lower.   |
|  | Worn or damaged throat seals.   | Clean or service the pump lower.   |
|  | Leak in the system and system is attempting to maintain stall pressure. | Check all fittings for a loose connection/leak.  |
| Control knob function does not line up with indicators on label. | Control knob requires calibration.                                      | See <b>Control Knob Calibration</b> , page 29.   |
| Excessive noise while operating.                                 | ProConnect components damaged.  | Replace ProConnect components.   |
|  | Damaged ball screw assembly.  | Replace ball screw assembly.   |
|  | Throat seals are dried out.   | Add TSL to packing nut/wet cup.  |
| Excessive material leakage into packing nut/wet cup.             | Throat packing nut is loose (if applicable).                            | Adjust packing nut/wet cup torque. See <b>Shutdown and Care of the Pump Lower*</b> , page 27.  |
|  | Throat packings are worn or damaged.                                    | Clean or service the pump lower.   |
|  | Displacement rod is worn or damaged.                                    | Clean or service the pump lower.   |

# ProGuard™ Codes

If any ProGuard codes are active, the lowest numbered code will be indicated by the number of blinks on the red ProGuard status light.

ProGuard codes can be cleared by toggling the Power Switch (C) **OFF** and back **ON** quickly.

**NOTE:** The system will not operate while any ProGuard codes are present.

| ProGuard Code | Problem                                       | Cause  | Solution   |
|---------------|---|--|--|
| 4             | High Incoming Voltage Detected                | Incoming AC voltage is above acceptable operating range.   | Locate good voltage supply to prevent damage to electronics.   |
| 8             | Low Incoming Voltage Detected                 | Incoming AC voltage is below acceptable operating range.   | Locate good voltage supply to prevent damage to electronics.   |
| 9             | Encoder Communication Fault                   | Communication between encoder and motor control board failed.                                      | Turn the pump off, unplug from power supply and wait five minutes. Remove shroud. Check encoder cable and connections.   |
| 10            | Control Board Thermal Protection Enabled      | Motor controller too hot.  | Let the controller cool down. Ensure airflow to the unit is not restricted and system is in allowable temperature range. Fan should be running. If fan is not running, turn the pump off, unplug from power and wait five minutes. Remove shroud and check fan and fan wiring. When pump is powered on, the fan should spin for ~10 seconds. |
| 11            | Pump Diving Protection Enabled                | The speed of the pump increased rapidly and diving was detected.                                   | Confirm material is feeding properly and purge any air in the system. Clear error and continue operation.  |
| 12            | Excessive Current Protection Enabled          | Motor current too high.  | Turn the pump off and wait five minutes before turning back on. If problems persist, call Graco technical assistance.  |
| 14            | Encoder Calibration Failure                   | The encoder calibration procedure did not complete due to timeout or pump movement was restricted. | The most common cause of encoder calibration failure is the pump not being able to move. Relieve pressure and provide a low restriction pathway for the fluid. Alternatively, remove the pump driver from the pump lower. Repeat the encoder calibration.  |
| 15            | Motor Not Spinning, No Motor Current Detected | The pump was commanded to move, and no motor movement was detected.                                | Turn the pump off, unplug from power and wait five minutes. Remove shroud and check motor leads and connections. Check control board.  |

**NOTE:** Watchdog events are handled differently than the above ProGuard codes. The Watchdog status light will flash instead of the ProGuard status light. To clear a Watchdog event move the Control Knob (B) out of PRESSURE MODE (S) and into PRIME MODE (Q) to prime the pump. Once primed, return to normal operation.

# Available Models

## Model 2009958

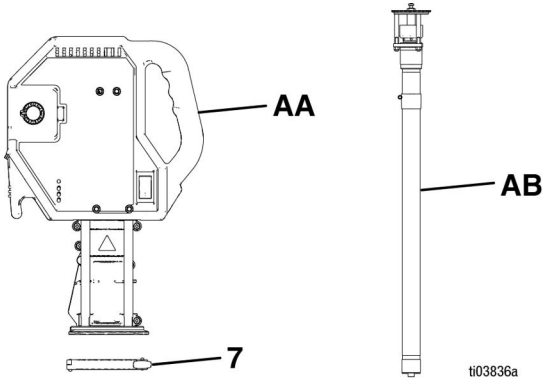

## Model 2009960

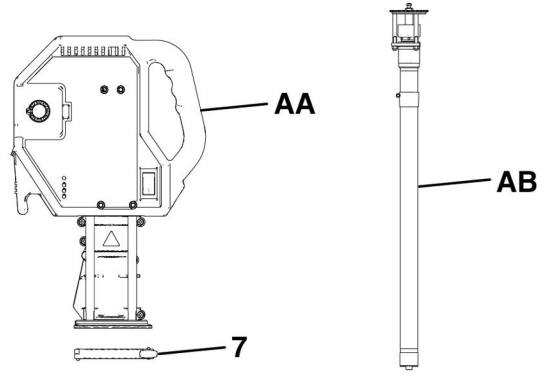

## Model 2009959

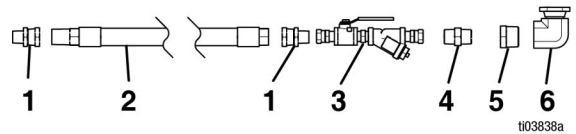
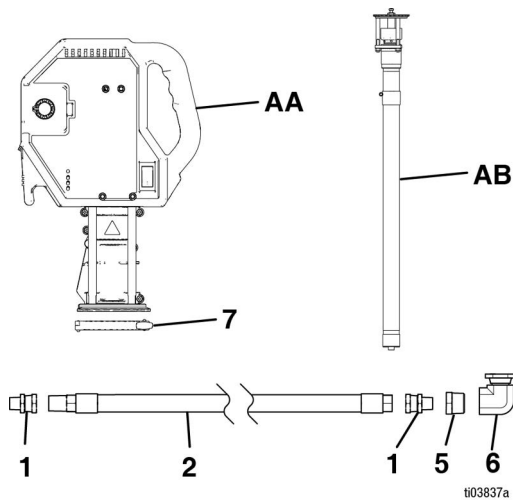

| Ref. | Part    | Description  | Qty |
|------|---------|--|-----|
| AA   | 2007625 | DRIVER   | 1   |
| AB   | 2008657 | PUMP, lower  | 1   |
| AB+  | 2003965 | T4 PUMP, lower   | 1   |
| 1    | 16W967  | FITTING, union, 3/4 NPT (m) x 1 NPSM (f) swivel        | 2   |
| 2    | 19B153  | HOSE, 1 in. ID, 1 NPT (MxM), 10 ft.                    | 1   |
| 3    | 256653  | KIT, Y strainer and valve                              | 1   |
| 4    | C20487  | FITTING, nipple. 3/4 NPT (m) x 3/4 NPT (m)             | 1   |
| 5    | 121620  | FITTING, bushing, 1-1/4 NPT (m) x 3/4 NPT (f)          | 1   |
| 6    | 121571  | FITTING, elbow, 1-1/4 NPT (m) x 1-1/4 NPSM (f), swivel | 1   |
| 7*   | 2007115 | KIT, ProConnect clamp                                  | 1   |

## Model 2011456

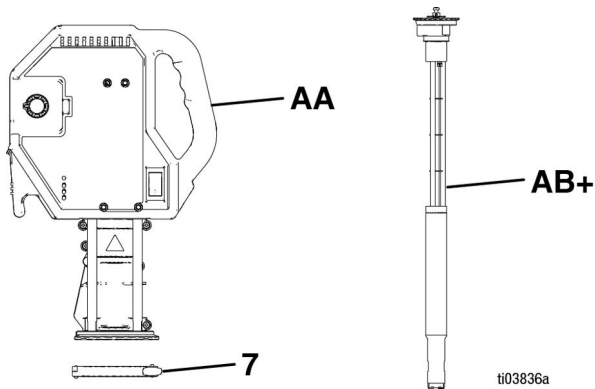







\* Included with Driver (2007625)

+ Model 2011456 only

## Available Repair Kits

| Ref. | Part    | Description                          | Qty |
|------|---------|--------------------------------------|-----|
|      | 2010541 | KIT, shroud                          | 1   |
|      | 2010542 | KIT, electronics                     | 1   |
|      | 2010553 | KIT, encoder                         | 1   |
|      | 2010547 | KIT, driver                          | 1   |
|      | 2010550 | KIT, ball-screw                      | 1   |
|      | 2010551 | KIT, driver, ProConnect parts        | 1   |
|      | 2010552 | KIT, lower, ProConnect parts         | 1   |
|      | 25N586  | KIT, pump, lower, rebuild            | 1   |
|      | 20B425  | KIT, potentiometer                   | 1   |
|      | 2007115 | KIT, ProConnect clamp                | 1   |
|      | 26D296  | KIT, IEC, field wireable plug        | 1   |
|      | 17N758  | KIT, IEC, North America 120V<br>plug | 1   |
|      | 242005  | KIT, IEC Australia plug              | 1   |
|      | 2010665 | KIT, power switch                    | 1   |
|      | 2010996 | KIT, fan                             | 1   |

## Torque Specifications (for all parts drawings)

| Ref.  | Torque                          |
|---|---------------------------------|
|  | 40-45 in-lb (4.5 - 5.0 N•m)     |
|  | 10-15 in-lb (1.13 - 1.7 N•m)    |
|  | 4-6 in-lb (0.45 - 0.68 N•m)     |
|  | 110-120 in-lb (12.4 - 13.5 N•m) |
|  | 15-20 ft-lb (20.3 - 27.1 N•m)   |
|  | 50-60 ft-lb (67.8 - 81.3 N•m)   |
|  | 30-35 in-lb (3.4 - 3.9 N•m)     |

# Parts, Kits

## Kit, Shroud (2010541)

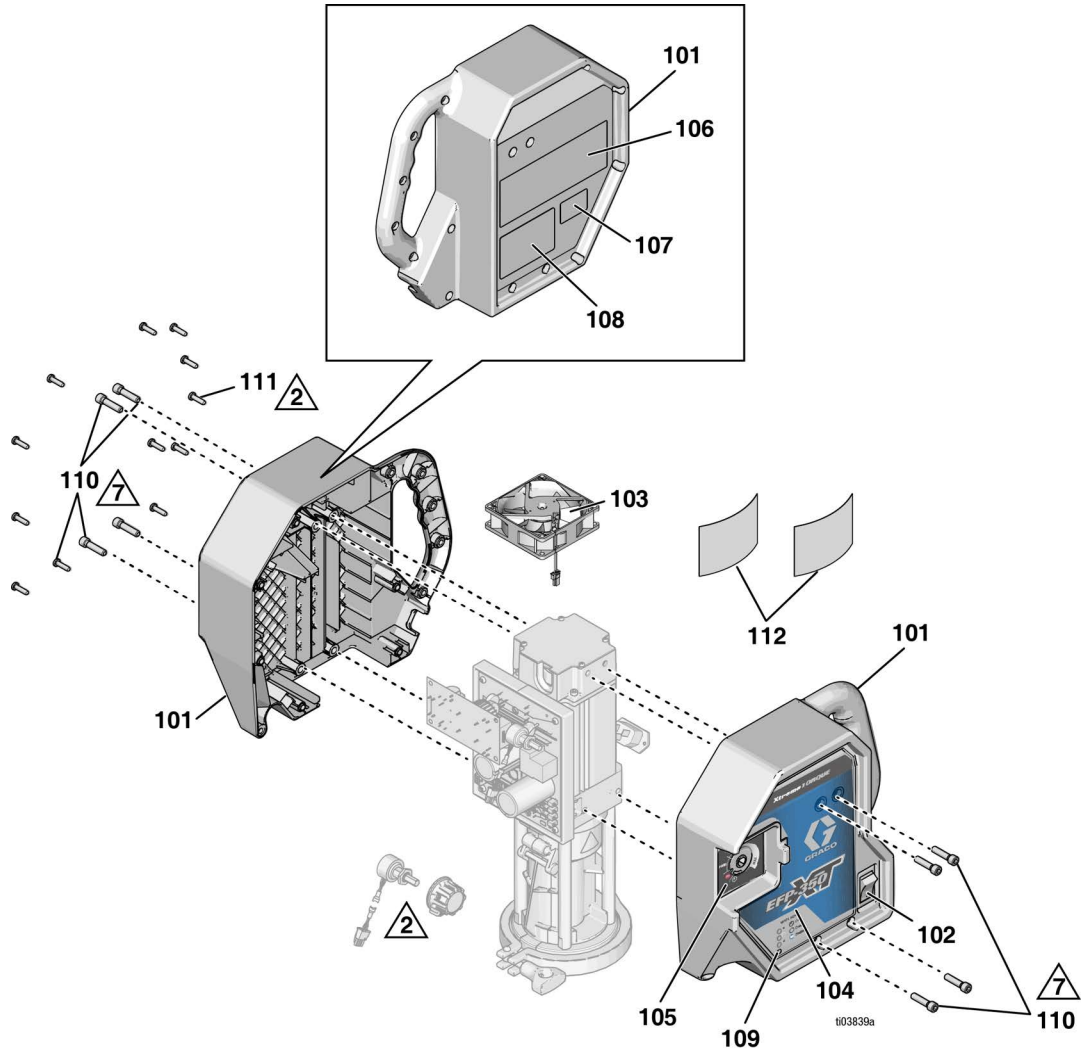

| Ref. | Part    | Description            | Qty | Ref. | Part | Description                        | Qty |
|------|---------|------------------------|-----|------|------|------------------------------------|-----|
| 101  |         | SHROUD, painted        | 1   | 108  |      | KIT, label, metalized              | 1   |
| 102  | 2010665 | POWER SWITCH           | 1   | 109  |      | LIGHT PIPES                        | 4   |
| 103  |         | FAN                    | 1   | 110  |      | SCREW, socket head, 1/4-20 x 1 in. | 8   |
| 104  |         | LABEL, branding        | 1   | 111  |      | SCREW, #8-16 x 0.625 in. plastite  | 12  |
| 105  |         | LABEL, operation       | 1   | 112  |      | LABEL, identification A/B          | 1   |
| 106▲ | 2010100 | LABEL, safety, warning | 1   |      |      |                                    |     |
| 107  |         | LABEL, Made in USA     | 1   |      |      |                                    |     |

▲ Replacement safety labels, tags, and cards are available at no cost.

△ See **Torque Specifications (for all parts drawings)**, page 36.

# Kit, Electronics (2010542)

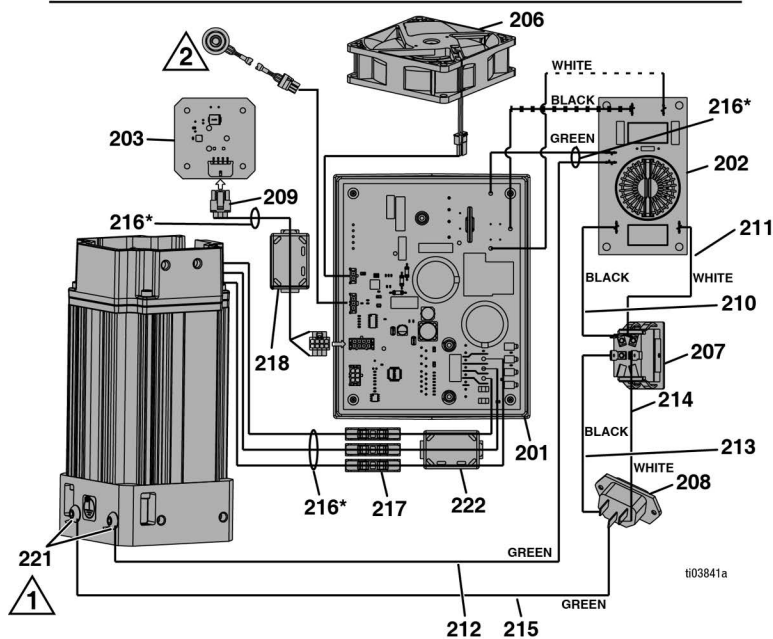
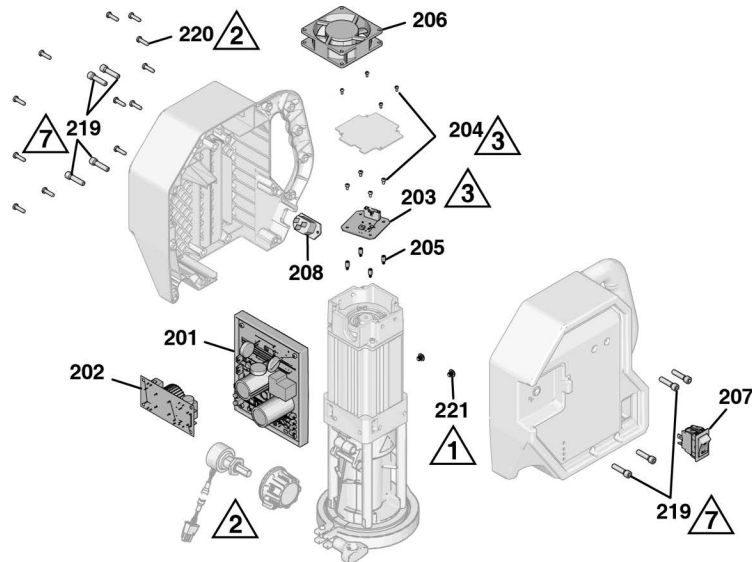

See, **Wire Routing**, page 47, for proper routing of wiring.

ti03841a

| Ref. | Part    | Description                        | Qty | Ref. | Part | Description                           | Qty |
|------|---------|------------------------------------|-----|------|------|---------------------------------------|-----|
| 201  |         | MAIN BOARD                         | 1   | 214  |      | WIRE, switch, power, comm, EFP-350    | 1   |
| 202  |         | GROUND CHOKE BOARD                 | 1   | 215  |      | WIRE, switch, power, ground, EFP-350  | 1   |
| 203  |         | ENCODER BOARD                      | 1   | 216  |      | ZIP TIES                              | 1   |
| 204  |         | SCREWS, pan head M3-0.5 x 6 mm     | 8   | 217  |      | CONNECTOR, Wago, in-line              | 3   |
| 205  |         | STAND-OFFS                         | 4   | 218  |      | FERRITE                               | 1   |
| 206  |         | FAN                                | 1   | 219  |      | SCREW, socket head, 1/4-20 x 1 in.    | 8   |
| 207  | 2010665 | POWER SWITCH                       | 1   | 220  |      | SCREW, #8-16 x 0.625 in. plastite     | 12  |
| 208  |         | IEC PORT                           | 1   | 221  |      | SCREW, button head, 1/4-20 x 0.25 in. | 2   |
| 209  |         | CABLE, encoder                     | 1   | 222  |      | Ferrite                               | 1   |
| 210  |         | WIRE, power, line EFP-350          | 1   |      |      |                                       |     |
| 211  |         | WIRE, comm, EFP-350                | 1   |      |      |                                       |     |
| 212  |         | WIRE, ground, EFP-350              | 1   |      |      |                                       |     |
| 213  |         | WIRE, switch, power, line, EFP-350 | 1   |      |      |                                       |     |

See **Torque Specifications (for all parts drawings)**, page 36.

## Kit, Encoder (2010553)

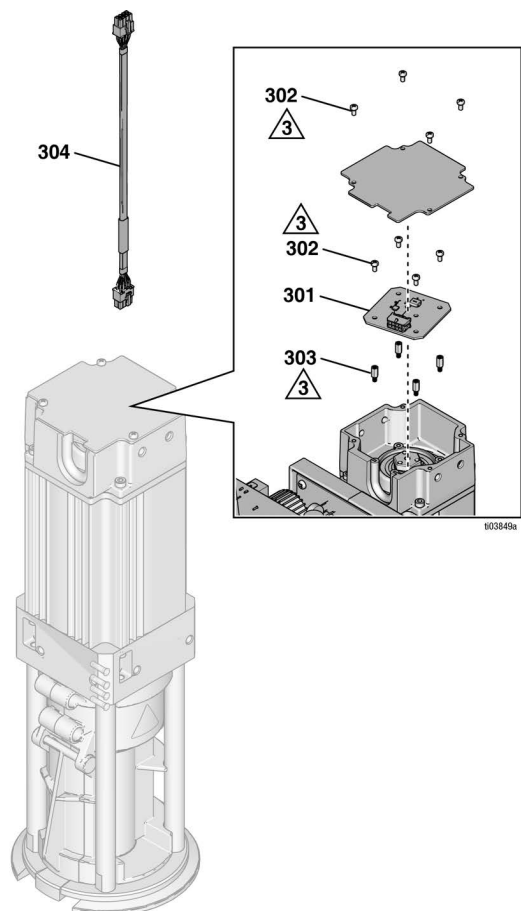

| Ref. | Part | Description                    | Qty |
|------|------|--------------------------------|-----|
| 301  |      | ENCODER BOARD                  | 1   |
| 302  |      | SCREW, pan head, M3-0.5 x 6 mm | 8   |
| 303  |      | STAND -OFFS                    | 4   |
| 304  |      | CABLE, encoder                 | 1   |

 See **Torque Specifications (for all parts drawings)**, page 36.

## Kit, Driver (2010547)

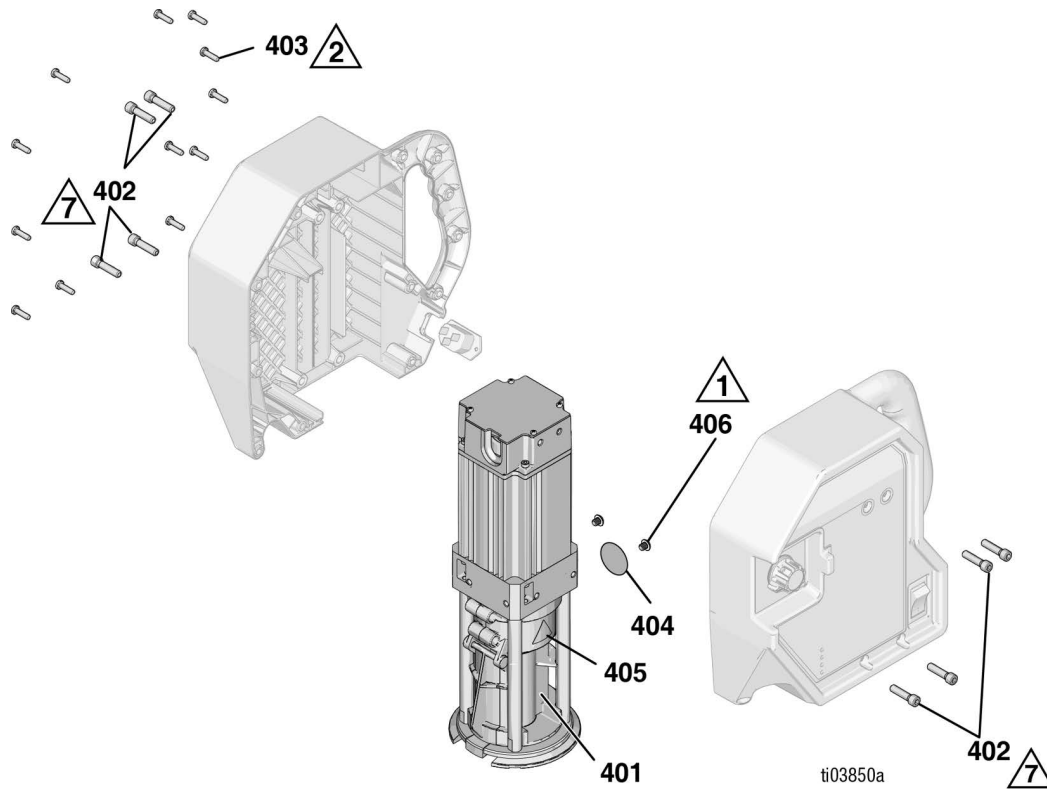

| Ref. | Part   | Description                           | Qty |
|------|--------|---------------------------------------|-----|
| 401  |        | DRIVER                                | 1   |
| 402  |        | SCREW, socket head, 1/4-20 x 1 in.    | 8   |
| 403  |        | SCREW, #8-16 x 0.625 in. plastite     | 12  |
| 404  |        | LABEL, ground symbol                  | 1   |
| 405▲ | 15H108 | LABEL, safety                         | 1   |
| 406  |        | SCREW, button head, 1/4-20 x 0.25 in. | 2   |

▲ Replacement safety labels, tags, and cards are available at no cost.



See **Torque Specifications (for all parts drawings)**, page 36.

## Kit, Ball-Screw (2010550)

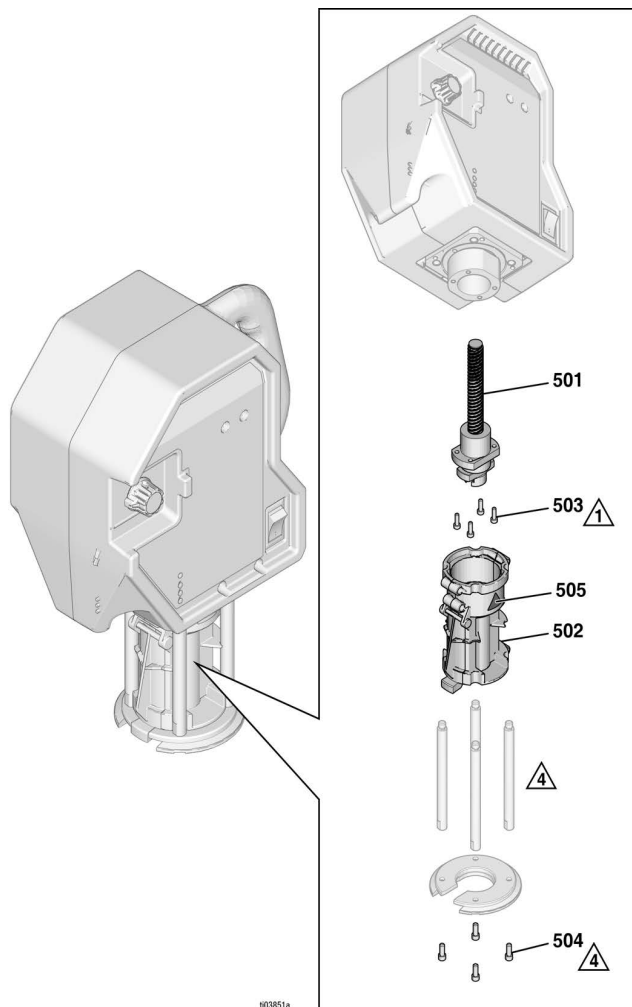

| Ref. | Part   | Description                               | Qty |
|------|--------|---|-----|
| 501  |        | ASSEMBLY, ball screw                      | 1   |
| 502  |        | GUIDE/COVER, ball screw                   | 1   |
| 503  |        | SCREW, socket head, M5-0.8 x 16 mm, patch | 4   |
| 504  |        | SCREW, socket head, 1/4-20 x 0.625 in.    | 4   |
| 505▲ | 15H108 | LABEL, safety                             | 1   |
| 506  |        | LUBE PACK                                 | 1   |

▲ Replacement safety labels, tags, and cards are available at no cost.

⚠ See **Torque Specifications (for all parts drawings)**, page 36.

## Kit, Driver, Pro-Connect (2010551)

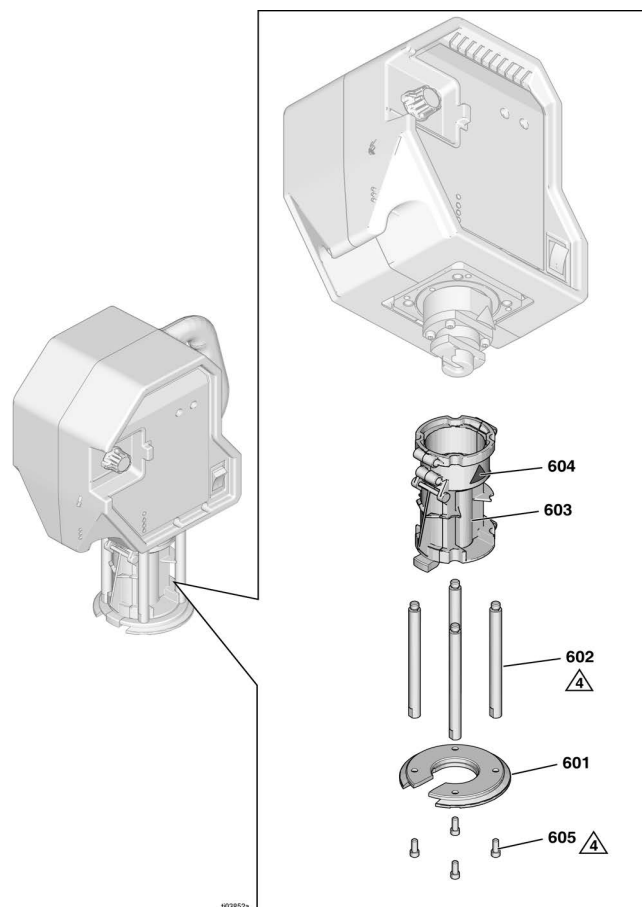

| Ref. | Part   | Description                            | Qty |
|------|--------|--|-----|
| 601  |        | FLANGE, driver                         | 1   |
| 602  |        | TIE, rods, driver                      | 4   |
| 603  |        | GUIDE/COVER, ball screw                | 1   |
| 604▲ | 15H108 | LABEL, safety                          | 1   |
| 605  |        | SCREW, socket head, 1/4-20 x 0.625 in. | 4   |

▲ Replacement safety labels, tags, and cards are available at no cost.

⚠ See **Torque Specifications (for all parts drawings)**, page 36.

## Pump Lower Kits\*

\* Excludes model 2011456, see manual 3A8598

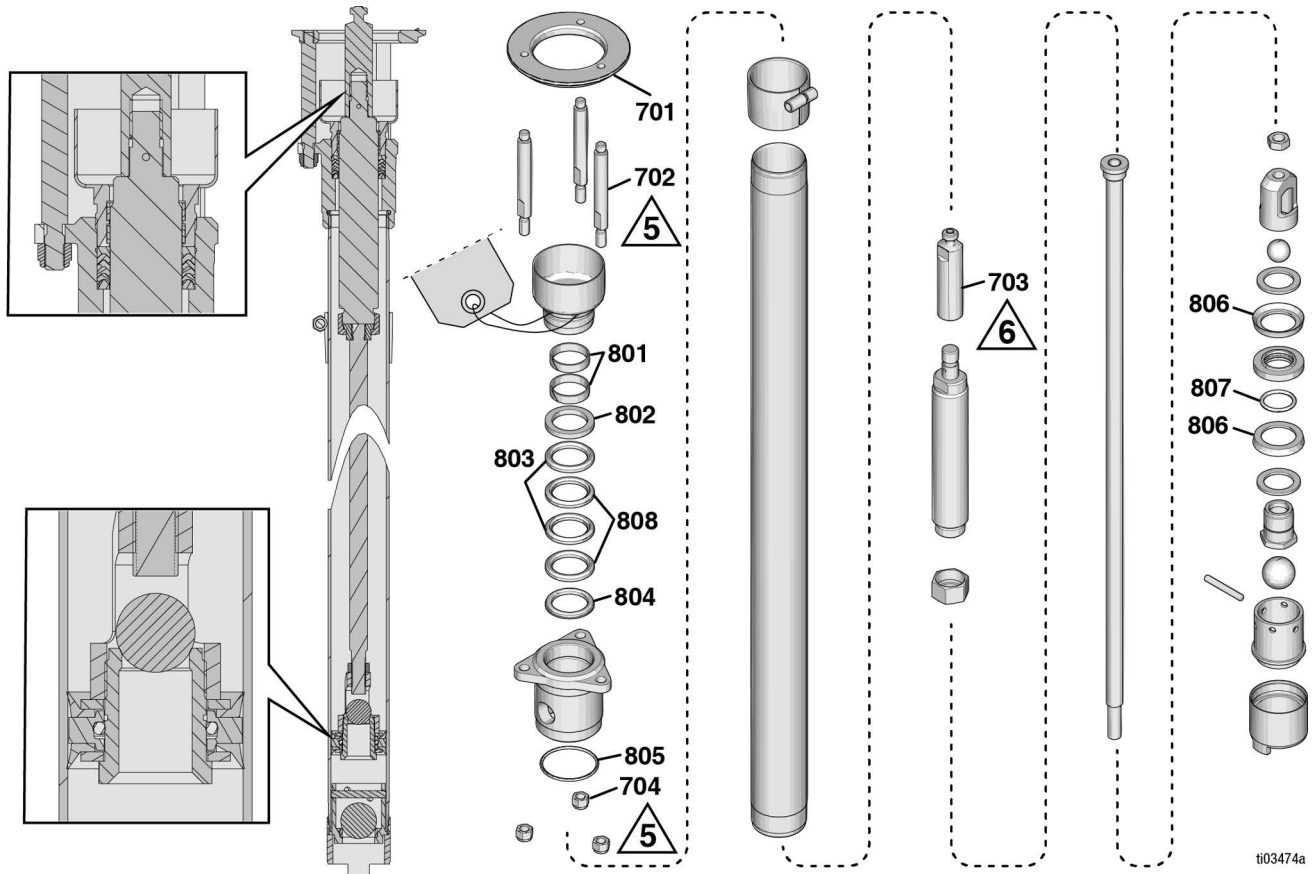

### Kit, Lower, Pro-Connect, Parts List (2010552)\*

| Ref. | Part | Description       | Qty |
|------|------|-------------------|-----|
| 701  |      | FLANGE, lower     | 1   |
| 702  |      | TIE, rods, lower  | 3   |
| 703  |      | ADAPTER, pump rod | 1   |
| 704  |      | NUT, lock, 3/8-16 | 3   |

△ See **Torque Specifications (for all parts drawings)**, page 36.

### Kit, Pump Lower, Rebuild, Parts List (25N586)\*

| Ref. | Part   | Description                     | Qty |
|------|--------|---------------------------------|-----|
| 801  | 165287 | BEARING, rod                    | 2   |
| 802  | 165288 | GLAND, PKG female               | 1   |
| 803* | 162866 | PACKING, VEE, PTFE              | 2   |
| 804  | 164837 | GLAND, PKG male                 | 1   |
| 805  | 164782 | PACKING, O-ring                 | 1   |
| 806  | 162871 | PACKING, cup                    | 2   |
| 807  | 164623 | PACKING, O-ring                 | 1   |
| 808* | 176639 | PACKING, VEE, UHMW polyethylene | 2   |

\* Rebuild kit (208520) to convert pump lower to all PTFE seals contains all parts from 25N586, except 4 of ref. 803 and 0 of ref. 808.

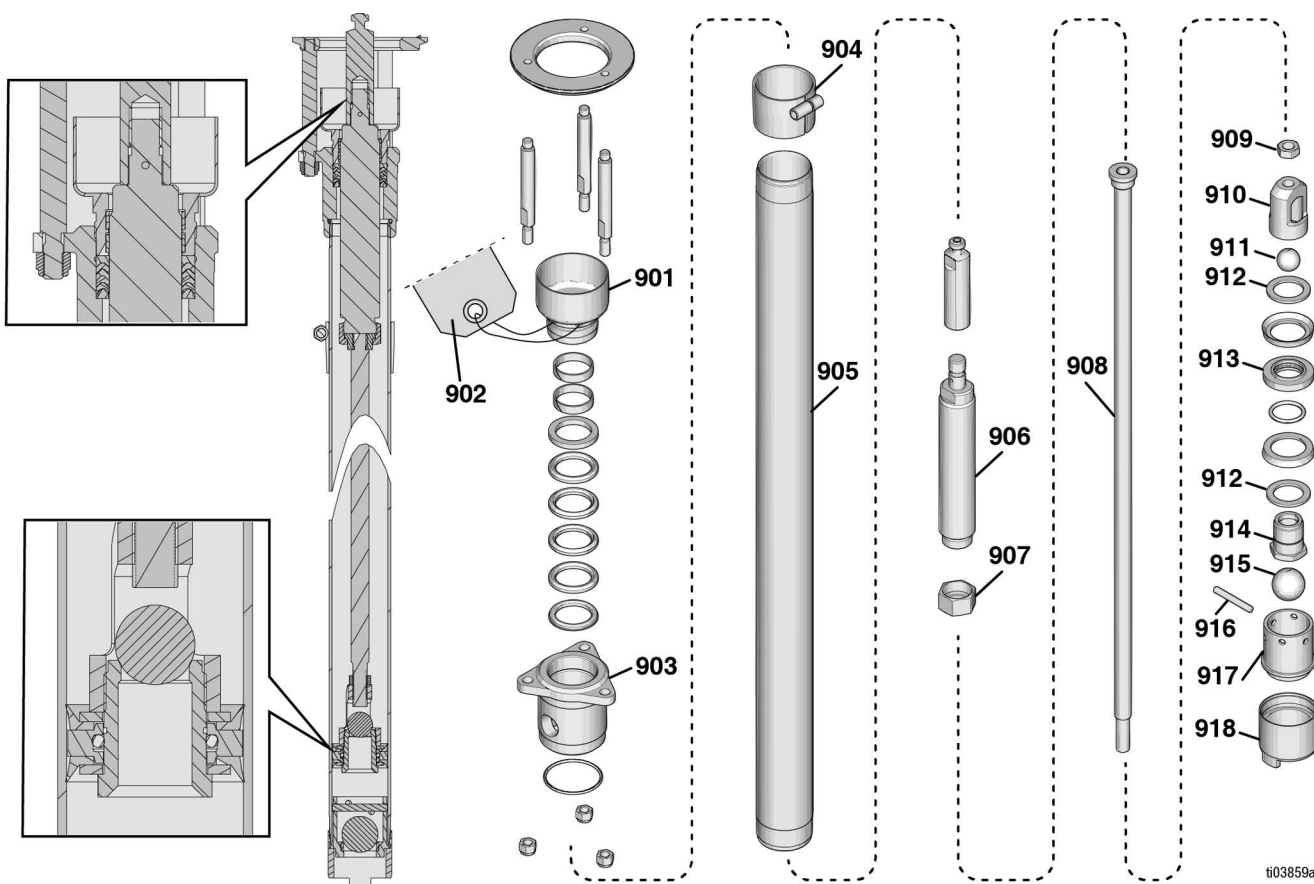

ti03859a

## Kit, Pump Lower, Parts List (2008657)\*

\* Excludes model 2011456, see manual 3A8598

| Ref. | Part   | Description             | Qty | Ref. | Part   | Description                  | Qty |
|------|--------|-------------------------|-----|------|--------|------------------------------|-----|
| 901  | 208312 | PACKING, nut/wet cup    | 1   | 911  | 100279 | BALL, piston valve, metallic | 1   |
| 902▲ | 172479 | LABEL, warning          | 1   | 912  | 171594 | WASHER, piston               | 2   |
| 903  | 192188 | HOUSING, outlet         | 1   | 913  | 158857 | SPACER, cup                  | 1   |
| 904  | 222308 | ADAPTER, bung 2 in. NPT | 1   | 914  | 156989 | SEAT, piston valve           | 1   |
| 905  | 186986 | HOUSING, cylinder       | 1   | 915  | 101178 | BALL, intake valve, metallic | 1   |
| 906  | 169504 | ROD, displacement       | 1   | 916  | 160726 | PIN, ball stop               | 1   |
| 907  | 166033 | NUT, coupling           | 1   | 917  | 204762 | SEAT, intake valve           | 1   |
| 908  | 208314 | ROD, piston             | 1   | 918  | 159839 | HOUSING, intake valve        | 1   |
| 909  | 100111 | NUT, piston valve       | 1   |      |        |                              |     |
| 910  | 157184 | HOUSING, piston valve   | 1   |      |        |                              |     |

▲ Replacement safety labels, tags, and cards are available at no cost.

### Kit, Potentiometer (20B425)

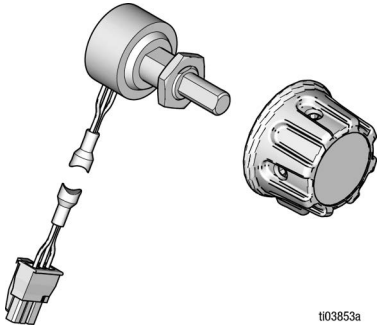

### Kit, IEC North America 120V Plug (17N758)

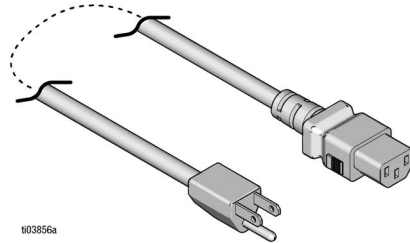

### Kit, ProConnect Clamp (2007115)



### Kit, IEC Australia Plug (242005)

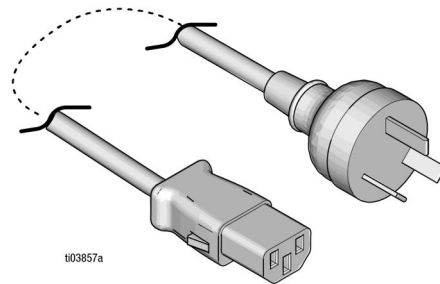

### Kit, IEC Field Wireable Plug (26D296)

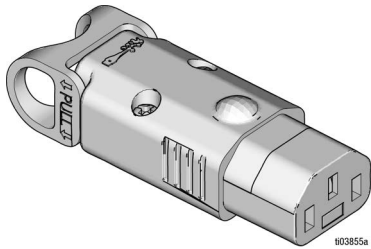

### Kit, Power Switch (2010665)

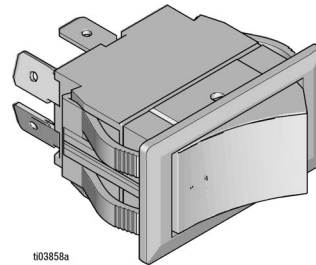

### Kit, IEC EU Plug (814-0339)

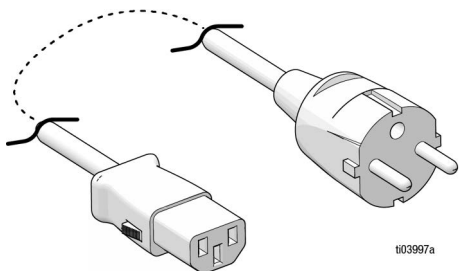

### Kit, Fan (2010996)

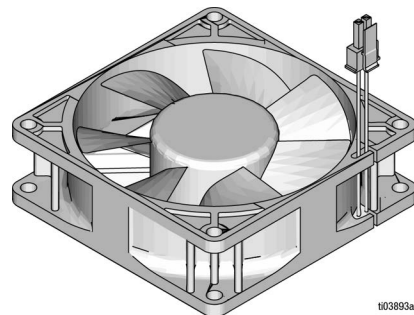

# Accessories

To ensure maximum pump performance, make sure all accessories are properly sized to meet your system requirements.

## Fluid Drain Valve (2010735)

500 psi (3.45 MPa, 34.5 bar) Maximum Working Fluid Pressure

Required in the system to relieve fluid pressure in the hose and/or gun/dispense valve. Install the drain valve so that it points down and the handle points up when the valve is opened.

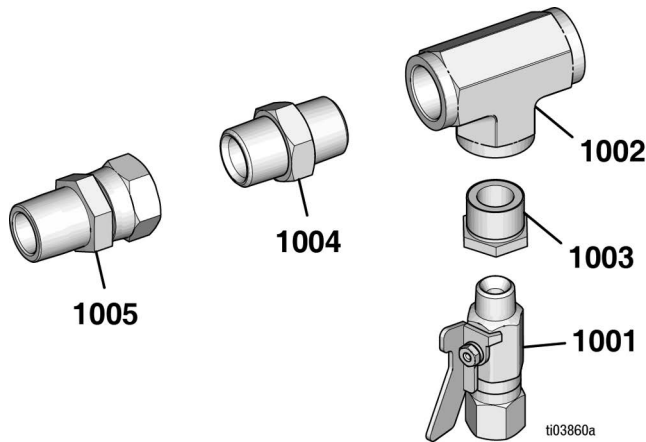

| Ref. | Part   | Description                               | Qty |
|------|--------|---|-----|
| 1001 | 237534 | VALVE, ball; 3/8 npt (m) x 3/8 npt (f)    | 1   |
| 1002 | 801787 | FITTING, tee 3/4 NPT(f)                   | 1   |
| 1003 | 100505 | FITTING, bushing, 3/4 NPT(m) x 3/8 NPT(m) | 1   |
| 1004 | C20487 | FITTING, nipple, 3/4 NPT(m) x 3/4 NPT(m)  | 1   |
| 1005 | 118459 | FITTING, union, 3/4 NPT(m) x 3/4 NPSM(f)  | 1   |

## Return Tube/Desiccant Dryer

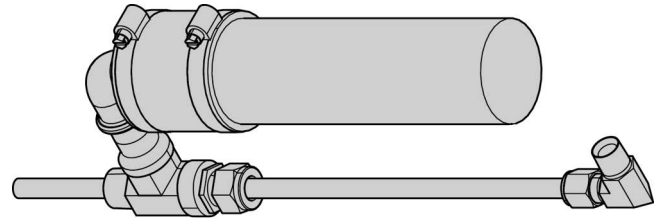

| Part   | Description  | Qty |
|--------|--|-----|
| 246477 | KIT, carbon steel return tube                          | 1   |
| 246978 | KIT, carbon steel return tube; with hose               | 1   |
| 24E379 | KIT, carbon steel return tube; with moisture-lock hose | 1   |
| 247616 | KIT, desiccant dryer, no return tube                   | 1   |

## Tote Extension (2010810)\*

\* Excludes model 2011456

600 psi (4.14 MPa, 41.4bar) Maximum Working Fluid Pressure

Used for extending pump inlet close to bottom of tote tanks.

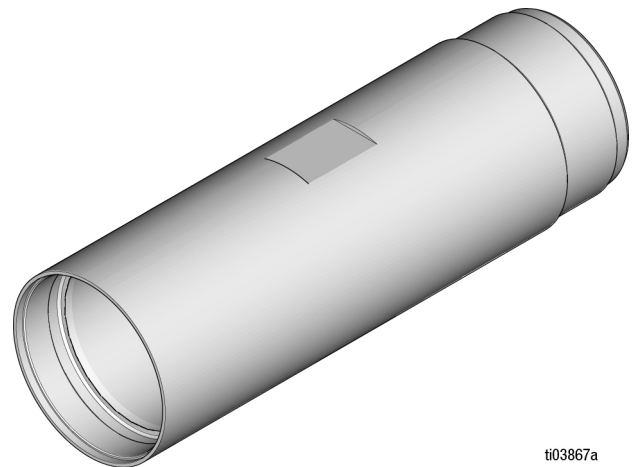

## Inlet Filter (2010811)\*

\* Excludes model 2011456

*600 psi (4.14 MPa, 41.4bar) Maximum Working Fluid Pressure*

Intended to help keep large debris, such as rocks and solid particles, from entering the pump.



# Wire Routing

\*Add zip tie around specified wires.

## Fan

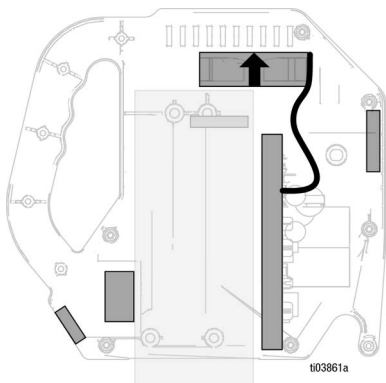

## Ground Choke Board

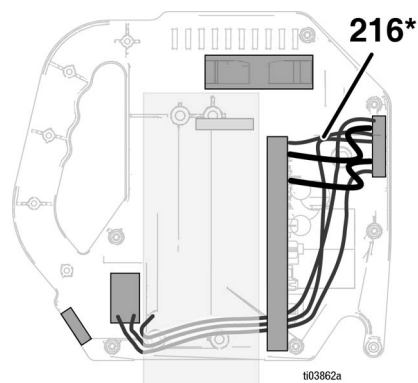

## Encoder Board

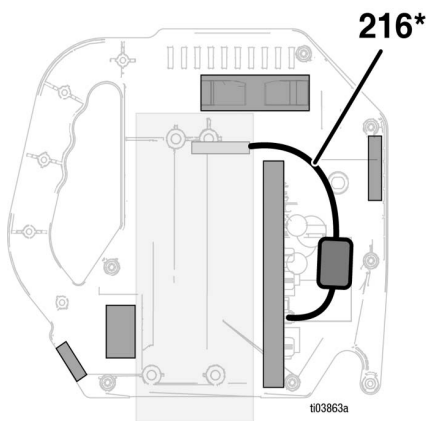

## Motor

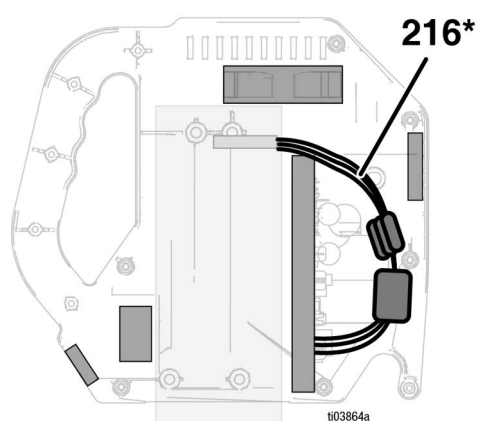

## Power Switch/Power Port

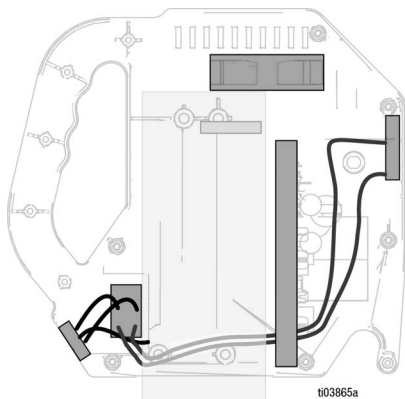

## Potentiometer

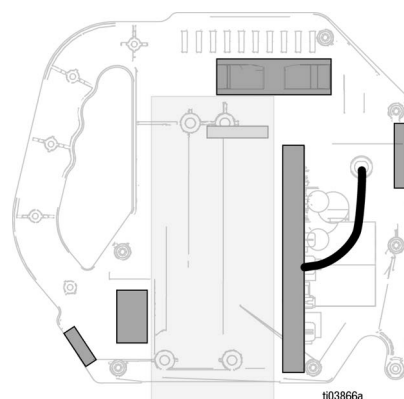

# Product Dimensions

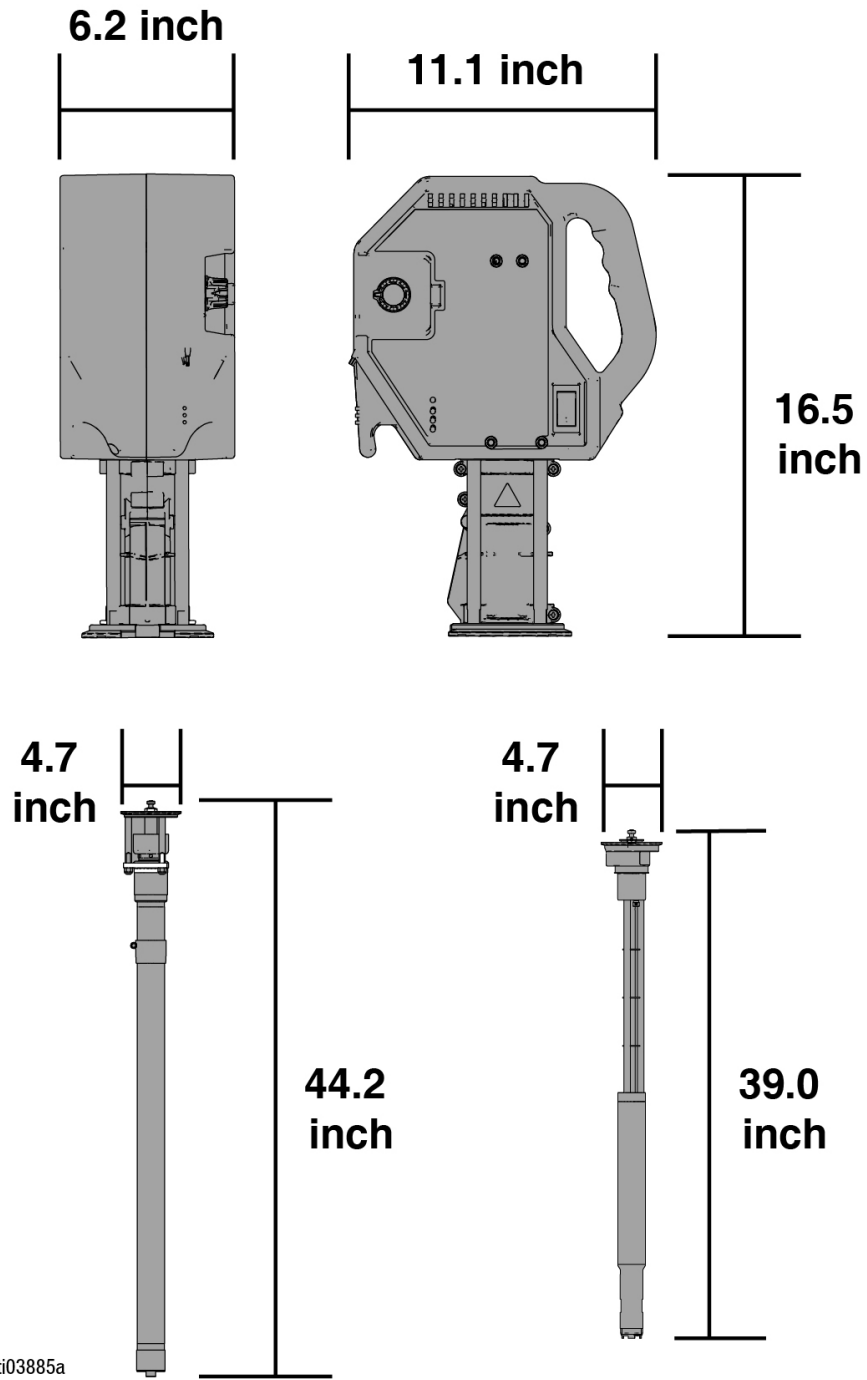

# Technical Specifications

| <b>EFP-350 XT Electric Feed Pump</b>   |  |                   |
|--|--|-------------------|
|  | <b>US</b>  | <b>Metric</b>     |
| Maximum fluid working pressure   | 350 psi  | 2.4 MPa, 24.1 bar |
| Maximum continuous outlet flow   | 5 gpm  | 18.9 lpm          |
| Pump cycles per 1 gallon (3.8 liters)  | 28.5   |                   |
| Volume per pump cycle  | 0.035 gallons  | 0.133 liters      |
| Maximum ambient temperature  | 120°F  | 49°C              |
| Maximum fluid temperature  | 190°F  | 88°C              |
| <b>Inlet/Outlet Sizes</b>  |  |                   |
| Fluid outlet size (Pump Lower)   | 3/4-14 in. npt (f)                                     |                   |
| <b>Materials of Construction</b>   |  |                   |
| Wetted materials on all models   | Carbon steel, stainless steel, PTFE, UHMW Polyethylene |                   |
| <b>Weight</b>  |  |                   |
| Driver   | 20 lb.   | 9 kg              |
| Pump Lower (2008657)   | 20.5 lb  | 9.3 kg            |
| Pump Lower (2003965)   | 15.5 lb  | 7.0 kg            |
| <b>Electrical Ratings</b>  |  |                   |
| 100-120 VAC  | 10A, 50/60 Hz  |                   |
| 200-240 VAC  | 6A, 50/60 Hz   |                   |
| <b>Noise (dBa)</b>   |  |                   |
| Maximum sound pressure (ISO 3744)*   | 90.6 dBa   |                   |
| Maximum sound power (ISO 3744)   | 101.6 dBa  |                   |
| *Sound pressure measure 3.3 feet (1.0 meter) from equipment.                         |  |                   |
| <b>Notes</b>   |  |                   |
| All trademarks or registered trademarks are the property of their respective owners. |  |                   |

## California Proposition 65

CALIFORNIA RESIDENTS

 **WARNING:** Cancer and reproductive harm – [www.P65warnings.ca.gov](http://www.P65warnings.ca.gov).

# Recycling and Disposal

This section includes information on how to properly recycle and dispose of a product at the end of its useful life.

## End of Product Life

At the end of the product's useful life, dismantle and recycle it in a responsible manner.

- Perform the **Pressure Relief Procedure**, page 16.
- Drain and dispose of fluids according to applicable regulations. Refer to the material manufacturer's Safety Data Sheet.
- Remove motors, batteries, circuit boards, LCDs (liquid crystal displays), and other electronic components. Recycle according to applicable regulations.
- Do not dispose of batteries or electronic components with household or commercial waste. Deliver remaining product to a recycling facility.



# Graco Standard Warranty

Graco warrants all equipment referenced in this document which is manufactured by Graco and bearing its name to be free from defects in material and workmanship on the date of sale to the original purchaser for use. With the exception of any special, extended, or limited warranty published by Graco, Graco will, for a period of twelve months from the date of sale, repair or replace any part of the equipment determined by Graco to be defective. This warranty applies only when the equipment is installed, operated and maintained in accordance with Graco's written recommendations.

This warranty does not cover, and Graco shall not be liable for general wear and tear, or any malfunction, damage or wear caused by faulty installation, misapplication, abrasion, corrosion, inadequate or improper maintenance, negligence, accident, tampering, or substitution of non-Graco component parts. Nor shall Graco be liable for malfunction, damage or wear caused by the incompatibility of Graco equipment with structures, accessories, equipment or materials not supplied by Graco, or the improper design, manufacture, installation, operation or maintenance of structures, accessories, equipment or materials not supplied by Graco.

This warranty is conditioned upon the prepaid return of the equipment claimed to be defective to an authorized Graco distributor for verification of the claimed defect. If the claimed defect is verified, Graco will repair or replace free of charge any defective parts. The equipment will be returned to the original purchaser transportation prepaid. If inspection of the equipment does not disclose any defect in material or workmanship, repairs will be made at a reasonable charge, which charges may include the costs of parts, labor, and transportation.

**THIS WARRANTY IS EXCLUSIVE, AND IS IN LIEU OF ANY OTHER WARRANTIES, EXPRESS OR IMPLIED, INCLUDING BUT NOT LIMITED TO WARRANTY OF MERCHANTABILITY OR WARRANTY OF FITNESS FOR A PARTICULAR PURPOSE.**

Graco's sole obligation and buyer's sole remedy for any breach of warranty shall be as set forth above. The buyer agrees that no other remedy (including, but not limited to, incidental or consequential damages for lost profits, lost sales, injury to person or property, or any other incidental or consequential loss) shall be available. Any action for breach of warranty must be brought within two (2) years of the date of sale.

**GRACO MAKES NO WARRANTY, AND DISCLAIMS ALL IMPLIED WARRANTIES OF MERCHANTABILITY AND FITNESS FOR A PARTICULAR PURPOSE, IN CONNECTION WITH ACCESSORIES, EQUIPMENT, MATERIALS OR COMPONENTS SOLD BUT NOT MANUFACTURED BY GRACO.** These items sold, but not manufactured by Graco (such as electric motors, switches, hose, etc.), are subject to the warranty, if any, of their manufacturer. Graco will provide purchaser with reasonable assistance in making any claim for breach of these warranties.

In no event will Graco be liable for indirect, incidental, special or consequential damages resulting from Graco supplying equipment hereunder, or the furnishing, performance, or use of any products or other goods sold hereto, whether due to a breach of contract, breach of warranty, the negligence of Graco, or otherwise.

## **FOR GRACO CANADA CUSTOMERS**

The Parties acknowledge that they have required that the present document, as well as all documents, notices and legal proceedings entered into, given or instituted pursuant hereto or relating directly or indirectly hereto, be drawn up in English. Les parties reconnaissent avoir convenu que la rédaction du présente document sera en Anglais, ainsi que tous documents, avis et procédures judiciaires exécutés, donnés ou intentés, à la suite de ou en rapport, directement ou indirectement, avec les procédures concernées.

## Graco Information

For the latest information about Graco products, visit [www.graco.com](http://www.graco.com).

For patent information, see [www.graco.com/patents](http://www.graco.com/patents).

**TO PLACE AN ORDER**, contact your Graco distributor or call 1-800-690-2894 to identify the nearest distributor.

*All written and visual data contained in this document reflects the latest product information available at the time of publication.  
Graco reserves the right to make changes at any time without notice.*

Original instructions. This manual contains English. MM X021719

**Graco Headquarters:** Minneapolis

**International Offices:** Belgium, China, Japan, Korea

**GRACO INC. AND SUBSIDIARIES • P.O. BOX 1441 • MINNEAPOLIS MN 55440-1441 • USA**  
**Copyright 2025, Graco Inc. All Graco manufacturing locations are registered to ISO 9001.**

[www.graco.com](http://www.graco.com)  
Revision D, June 2025