

DCi Link Module

3A8471D

EN

For Ethernet communication to Graco E-Flo[®] DCi electric motors. For professional use only.

Not approved for use in explosive atmospheres or hazardous (classified) locations.

Model 2008499

DCi Link Module



Important Safety Instructions

Read all warnings and instructions in this manual before using the equipment. Save these instructions.

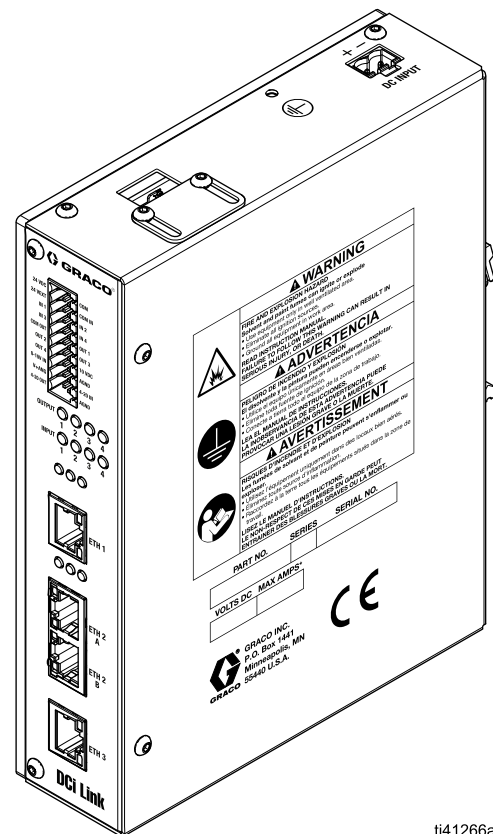

ti41266a



Contents

Models	2
Related Manuals	2
Safety Symbols	3
Warnings	4
DCi Link Operation Modes	6
Force Mode	6
Pressure Mode	6
Flow Mode	6
Typical Installation	7
Installation	8
Location	8
Grounding	8
Electrical Connections	9
Component Identification	13
LED Descriptions	13
Setup	14
I/O Wiring	14
Fieldbus Connections	19
Fieldbus LEDs	19
Computer Configuration	22
Connect to the User Interface	22
Log into DCi Link	23
Web Interface Navigation	23
IP Address Setup	24
Modify the IP Address	24
User Management	25
System Configuration	28
Pump Configuration	39
Enable Fieldbus	51
PROFINET	51
Modbus TCP	52
EtherNet/IP	52
Integration	53
Mapping	54
E-Flo DCi Data	55
Status-General	55
Setup-General	62
Setup-General Data Map (Read Only)	64
Profiles	66
Profile Data Map (Read Only)	68
Maintenance-General	70
Maintenance-General Data Map (Read Only) ..	70
Command-Status	71
Command-Status Data Map	72

Command-Setup	73
Command-Setup Data Map	75
Command-Profiles	77
Command-Profiles Data Map	79
Command-Maintenance	81
Command-Maintenance Data Map	81
DCi Link Data	82
Status-Module	82
Status-Module Data Map	82
Status-I/O	83
Status-I/O Data Map	83
Setup-General	84
Setup-General Data Map	84
Setup-Pressure Sensor	85
Setup-Pressure Sensor Data Map	85
Setup-Units	85
Setup-Units Data Map	85
Scheduler	86
Maintenance	87
Replace the Micro SD Card	87
Dimensions	88
Technical Specifications	90
Graco Standard Warranty	92

Models





Part	Description
2008499	DCi Link Module





Related Manuals

English Manual	Description
3A8352	E-Flo DCi Motor, Installation-Operation
3A7828	E-Flo DCi Sealed 4-Ball Pumps, Instructions
3A7826	E-Flo DCi Sealed 2-Ball Pumps, Instructions

Safety Symbols

The following safety symbols appear throughout this manual and on warning labels. Read the table below to understand what each symbol means.

Symbol	Meaning
	Equipment Misuse Hazard
	Fire and Explosion Hazard
	Eliminate Ignition Sources
	Follow Pressure Relief Procedure

Symbol	Meaning
	Ground Equipment
	Read Manual
	Ventilate Work Area
	Wear Personal Protective Equipment







Safety Alert Symbol

This symbol indicates: Attention! Become Alert! Look for this symbol throughout the manual to indicate important safety messages.

Warnings

The following warnings apply throughout this manual. Read, understand, and follow the warnings before using this equipment. Failure to follow these warnings can result in serious injury.

 WARNING	
   	<p>FIRE AND EXPLOSION HAZARD</p> <p>Flammable fumes, such as solvent and paint fumes, in work area can ignite or explode. Paint or solvent flowing through the equipment can cause static sparking. To help prevent fire and explosion:</p> <ul style="list-style-type: none">• Use equipment only in well-ventilated area.• Eliminate all ignition sources, such as pilot lights, cigarettes, portable electric lamps, and plastic drop cloths (potential static sparking).• Ground all equipment in the work area. See Grounding instructions.• Never spray or flush solvent at high pressure.• Keep work area free of debris, including solvent, rags and gasoline.• Do not plug or unplug power cords, or turn power or light switches on or off when flammable fumes are present.• Use only grounded hoses.• Hold gun firmly to side of grounded pail when triggering into pail. Do not use pail liners unless they are anti-static or conductive.• Stop operation immediately if static sparking occurs or you feel a shock. Do not use equipment until you identify and correct the problem.• Keep a working fire extinguisher in the work area.



WARNING



EQUIPMENT MISUSE HAZARD

Misuse can cause death or serious injury.



- Do not operate the unit when fatigued or under the influence of drugs or alcohol.
- Do not exceed the maximum working pressure or temperature rating of the lowest rated system component. See **Technical Specifications** in all equipment manuals.
- Use fluids and solvents that are compatible with equipment wetted parts. See **Technical Specifications** in all equipment manuals. Read fluid and solvent manufacturer's warnings. For complete information about your material, request Safety Data Sheets (SDSs) from distributor or retailer.
- Do not leave the work area while equipment is energized or under pressure.
- Turn off all equipment and follow the **Pressure Relief Procedure** when equipment is not in use.
- Check equipment daily. Repair or replace worn or damaged parts immediately with genuine manufacturer's replacement parts only.
- Do not alter or modify equipment. Alterations or modifications may void agency approvals and create safety hazards.
- Make sure all equipment is rated and approved for the environment in which you are using it.
- Use equipment only for its intended purpose. Call your distributor for information.
- Route hoses and cables away from traffic areas, sharp edges, moving parts, and hot surfaces.
- Do not kink or over bend hoses or use hoses to pull equipment.
- Keep children and animals away from work area.
- Comply with all applicable safety regulations.



PERSONAL PROTECTIVE EQUIPMENT

Wear appropriate protective equipment when in the work area to help prevent serious injury, including eye injury, hearing loss, inhalation of toxic fumes, and burns. Protective equipment includes but is not limited to:

- Protective eyewear, and hearing protection.
- Respirators, protective clothing, and gloves as recommended by the fluid and solvent manufacturer.

DCi Link Operation Modes

DCi Link was created for the simple integration of Graco E-Flo DCi pumps used in circulation or supply systems. (See the DCi manuals in **Related Manuals**, page 2, for installation and operation of the DCi motor and pumps.) These pumps have three modes of operation:

- Force Mode
- Pressure Mode
- Flow Mode

The mode used by an E-Flo DCi pump is determined by the active profile settings. DCi Link allows users to configure up to four pre-defined profiles plus one dynamic profile in networked applications.

Force Mode

In Force Mode or Pressure Mode, DCi Link tells the pump to maintain a specified target force, which can be equivalent to an approximate outlet pressure, while allowing the flow rate to vary to meet the system demand. The active profile of the pump sets the target force value. The pump maintains that value as long as the demand on the system's flow rate does not exceed the pump's capability.

For example, in the figure for the Force Mode, the pump is operating at setpoint (1) and maintaining the target force value. When additional demand is put on the system to supply material, the flow rate increases while maintaining the target force value.

Pressure Mode

In Pressure Mode, DCi Link tells the pump to maintain a specified target pressure, which can be equivalent to an approximate outlet pressure, while allowing the flow rate to vary to meet the system demand. The active profile of the pump sets the target pressure value. The pump maintains that value as long as the demand on the system's flow rate does not exceed the pump's capability.

For example, in the figure for the Force or Pressure Mode, the pump is operating at setpoint (1) and maintaining the target pressure value. When additional demand is put on the system to supply material, the flow rate increases while maintaining the target force value.

Flow Mode

In Flow Mode, DCi Link tells the pump to maintain a target flow rate during which force and pressure may vary. The active profile of the pump sets the target flow rate value. The pump maintains that value as long as the demand on the system's force does not exceed the pump's capability.

For example, in the figure for the Flow Mode, the pump is operating at setpoint (1) and maintaining the target flow rate value. When additional back pressure is applied to the system, the pump will increase the force to maintain the flow rate.

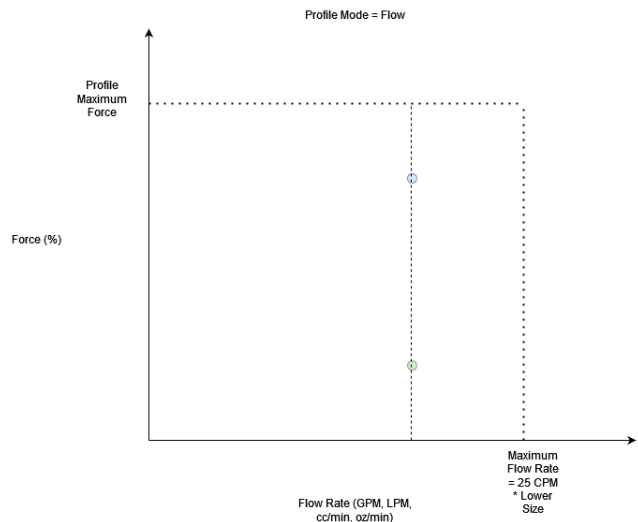
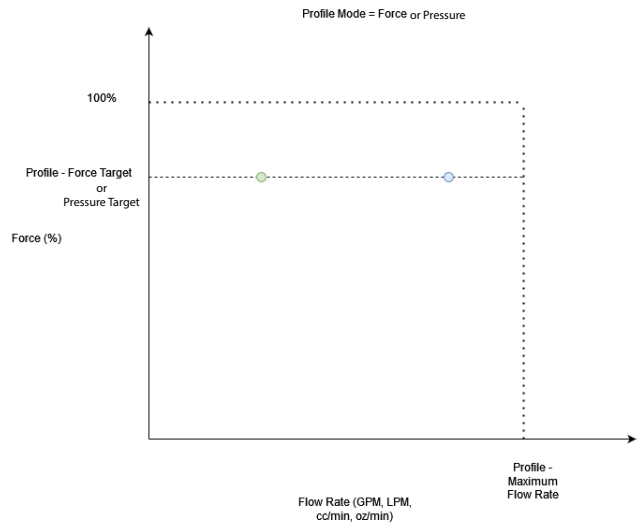
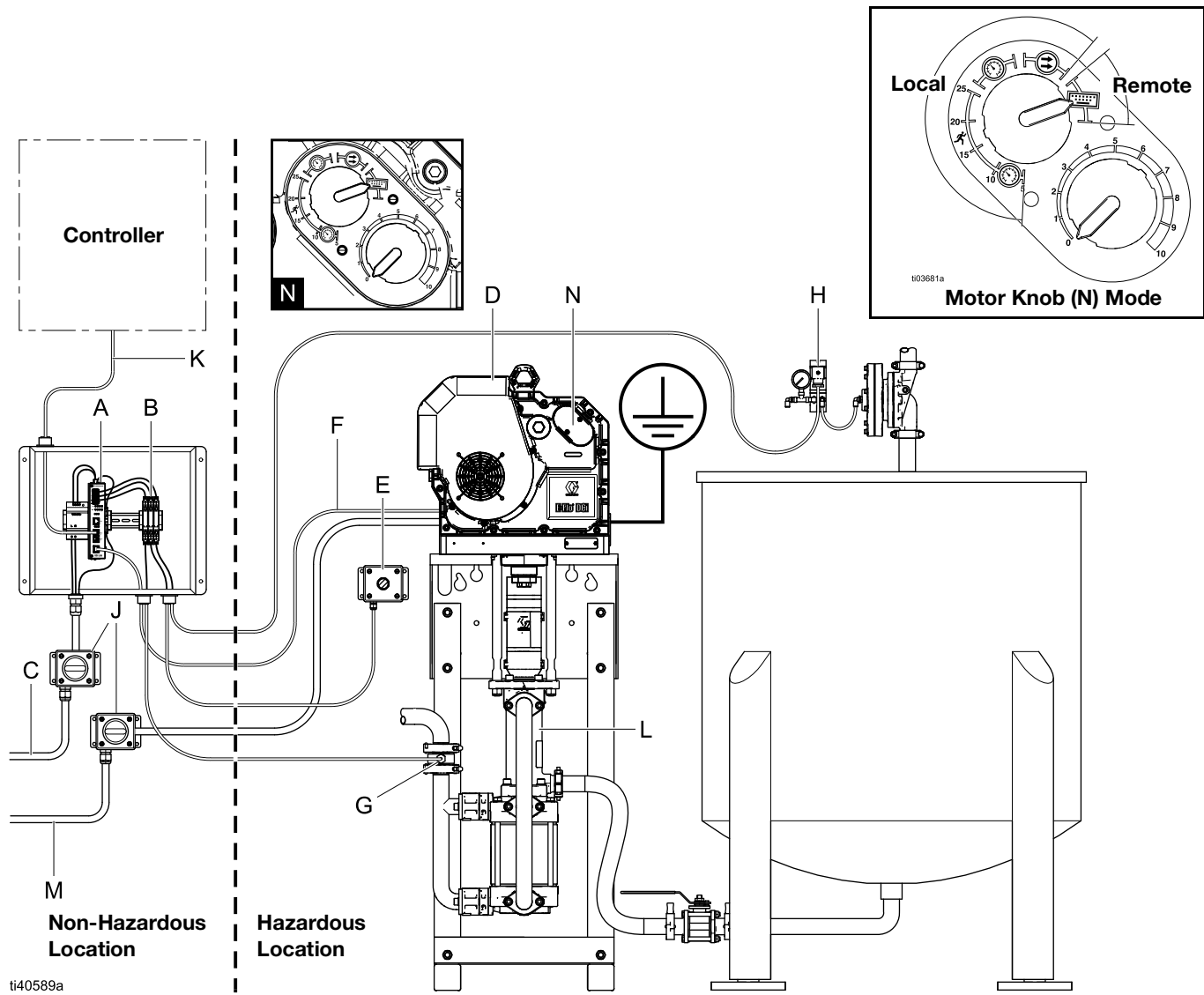

FIG. 1: Operation Modes

Typical Installation



ti40589a

FIG. 2: Typical Installation

Key:

Included Equipment

A Communication module (DCi Link)

Accessories and System Components (Not Included)

- B Intrinsically safe barriers
- C DCi Link Power supply
- D E-Flo DCi motor
- E Start/stop switch
- F DCi Motor Ethernet cable (ETH3) (CAT 5E or equivalent, RJ45 to M12, D-Code shielded cable)
- G Pressure transducer
- H Back Pressure Regulator (BPR) controller
- J Electrical disconnect
- K Fieldbus Ethernet cable (ETH2A/B)
- L Pump
- M Motor Power supply cable
- N Motor Knob

Installation

--	--	--	--	--

Installation of this equipment involves potentially hazardous procedures. Improper wiring and installation may cause fire and explosion if the work is not performed properly. All electrical wiring must be done by a qualified electrician and comply with all local codes and regulations.

Location

--	--	--	--	--

This equipment is not for use in explosive atmospheres. To avoid explosion, do not mount the communication module in a hazardous location area.

Mounting

Mount the module on a standard 35 mm DIN rail inside an IP54/NEMA3 enclosure, or higher. See Fig. 3.

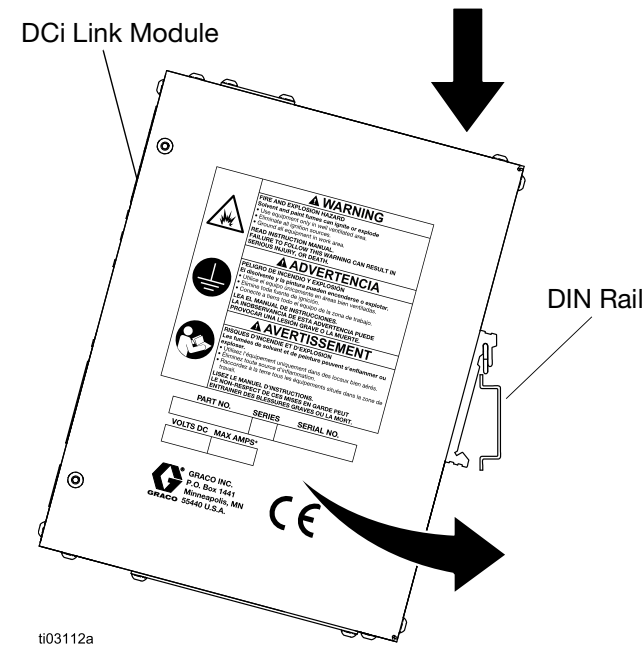

ti03112a
Fig. 3: Mount Module on DIN Rail

Grounding

--	--	--	--	--

The equipment must be grounded to reduce the risk of static sparking. Electric or static sparking can cause fumes to ignite or explode. Improper grounding can cause electric shock. Grounding provides an escape wire for the electric current.

Ground System Components

DCi Link: Grounding is required using the ground screw on the top of the module.

1. Loosen the ground screw.
2. Insert a ground wire.
3. Tighten the ground screw securely.
4. Connect the other end of the ground wire to a true earth ground.

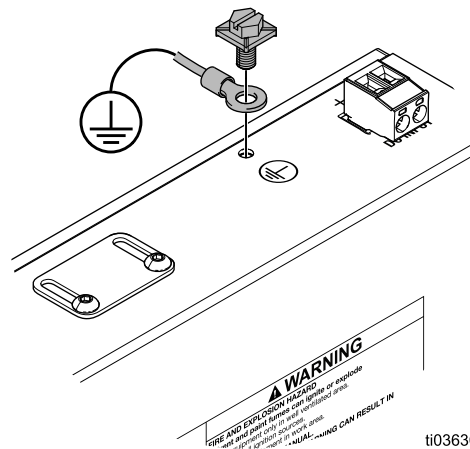

ti03630a
Fig. 4: Ground Screw

E-Flo DCi Motor (D): Follow the grounding instructions and warnings in your motor manual. See **Related Manuals**, page 2.

Pump (L): Follow the grounding instructions and warnings in your pump manual. See **Related Manuals**, page 2.

Electrical Connections



DC Power Source



Use a 24 V Class 2 Power Supply only.

1. Ensure that the DC power source is deenergized.
2. Attach power wires to the DC Power Connector, as shown in FIG. 5.

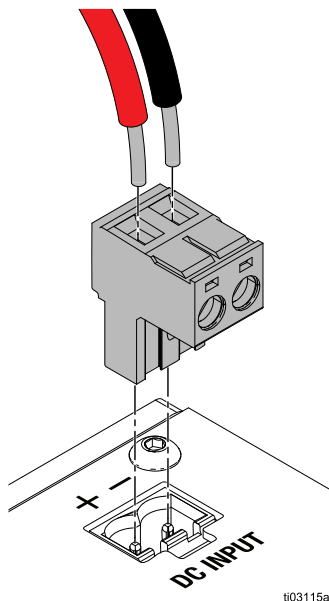

FIG. 5: DC Power Connector

3. Insert the DC Power Connector in the DC Input port.

Connect Ethernet Cable

Follow this procedure if a communication module is used for remote monitoring and control of the pump. See E-Flo DCi Motor Installation and Operation manual for more detail on motor installation. See **Related Manuals**, page 2.



All electrical wiring must be done by a qualified electrician and comply with all local codes and regulations.

1. Ensure that the electrical disconnect (J) is shut off and locked out. See Grounding in the E-Flo DCi Motor Installation and Operation manual. See **Related Manuals**, page 2.
2. Remove the Ethernet cover (CO) and NPT plug (NP).

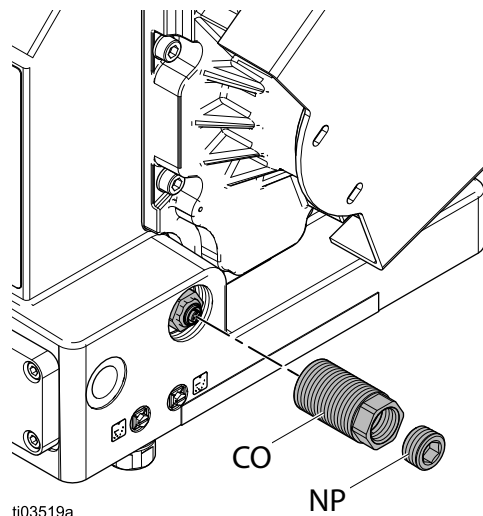



FIG. 6

3. Bring the Ethernet cable (M12, D-Coded 4 pole connector) through the 3/4- 14npt(f) of the Ethernet cover (CO). Connect the Ethernet cable to the M12 connection on the motor.

4. Torque the Ethernet cover to 54-58 in-lb (6.1-6.6 N-m).
5. Discard of NPT plug (NP).

 A conduit seal is required within 457 mm (18 in.) of the motor for US and Canadian installations.

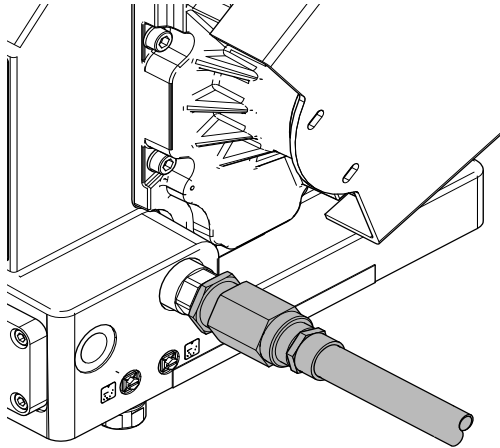

FIG. 7

System Components

Use the **Typical Installation**, page 7, as a guide to connect system components.

- **DCi motor (D):** Powers the pump.
- **Pressure transducer (sensor) (G):** Measures the pump outlet pressure. Purchase Graco part number 2009662 (5000 psi) or 2009660 (500 psi).
- **BPR controller (H):** Controls the back pressure regulator. Purchase Graco part number 2010425.

Electrical Accessories

Install accessories using adapters as necessary. Follow all electrical requirements for the communication module and related components.

- **Main supply wire (M):** Powers the motor.
- **Intrinsically safe barriers (B):** Limits energy between the hazardous and nonhazardous areas.
- **Electrical disconnect (J):** Install an electrical disconnect on the main supply wire.
- **Ethernet cable (K) (see typical install for terms):** Connect the Ethernet cable (K) to the PLC. See **Ethernet Connection**, page 21. Maximum cable length support is 270 ft (90 m).
- **Start/stop switch (E):** Temporarily runs or stops the motor. Must be approved for hazardous locations. Purchase Graco part number 2010462.

Point-to-Point Configuration

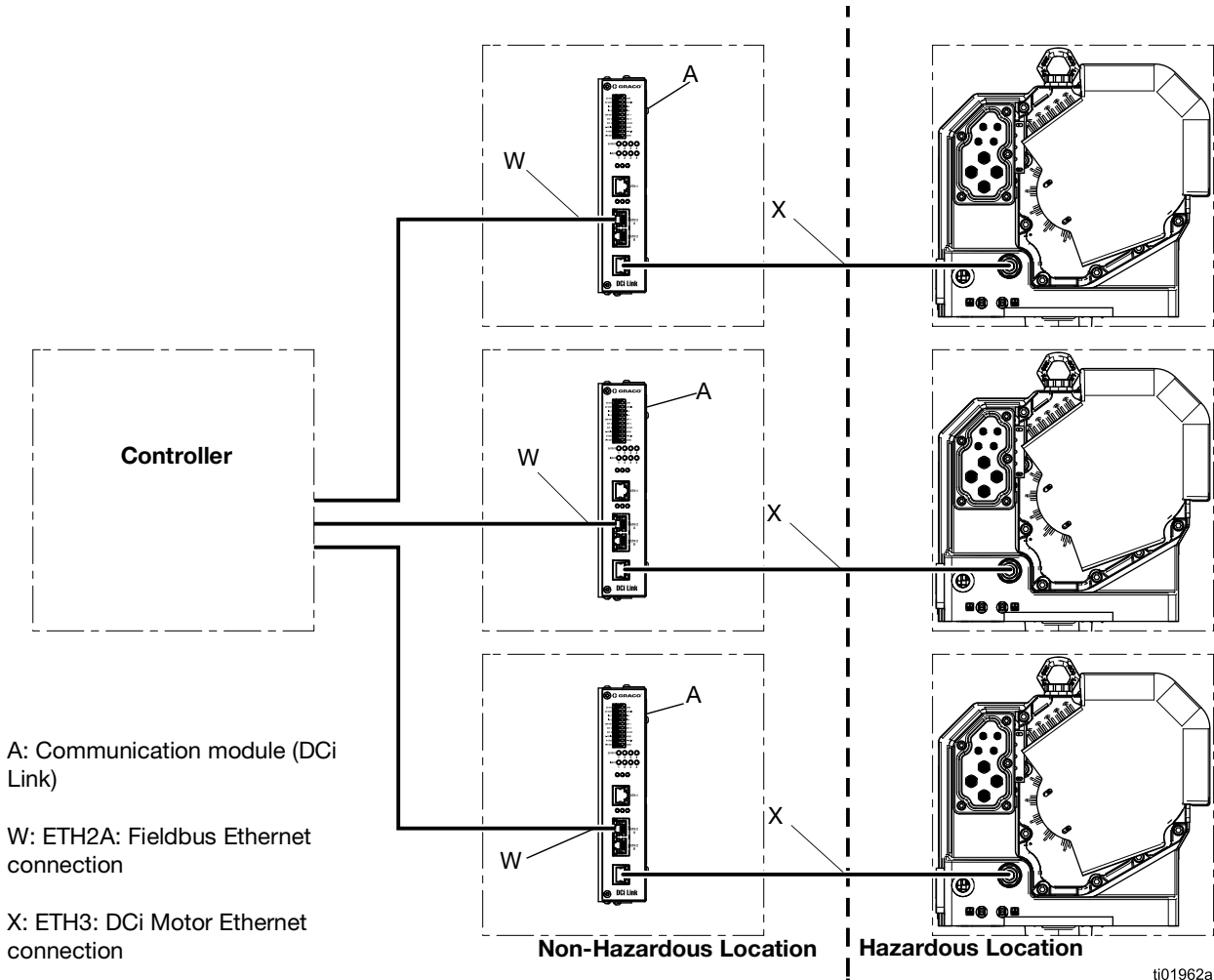

ti01962a

FIG. 8: Point-to-Point installation

Optional: Connect Multiple Modules

Daisy-Chain Configuration

Daisy-chain multiple modules together to manage multiple systems on one PLC.

NOTES:

- If one module fails, everything downstream will fail to communicate on the Fieldbus interface.
- Ring topology is not supported.

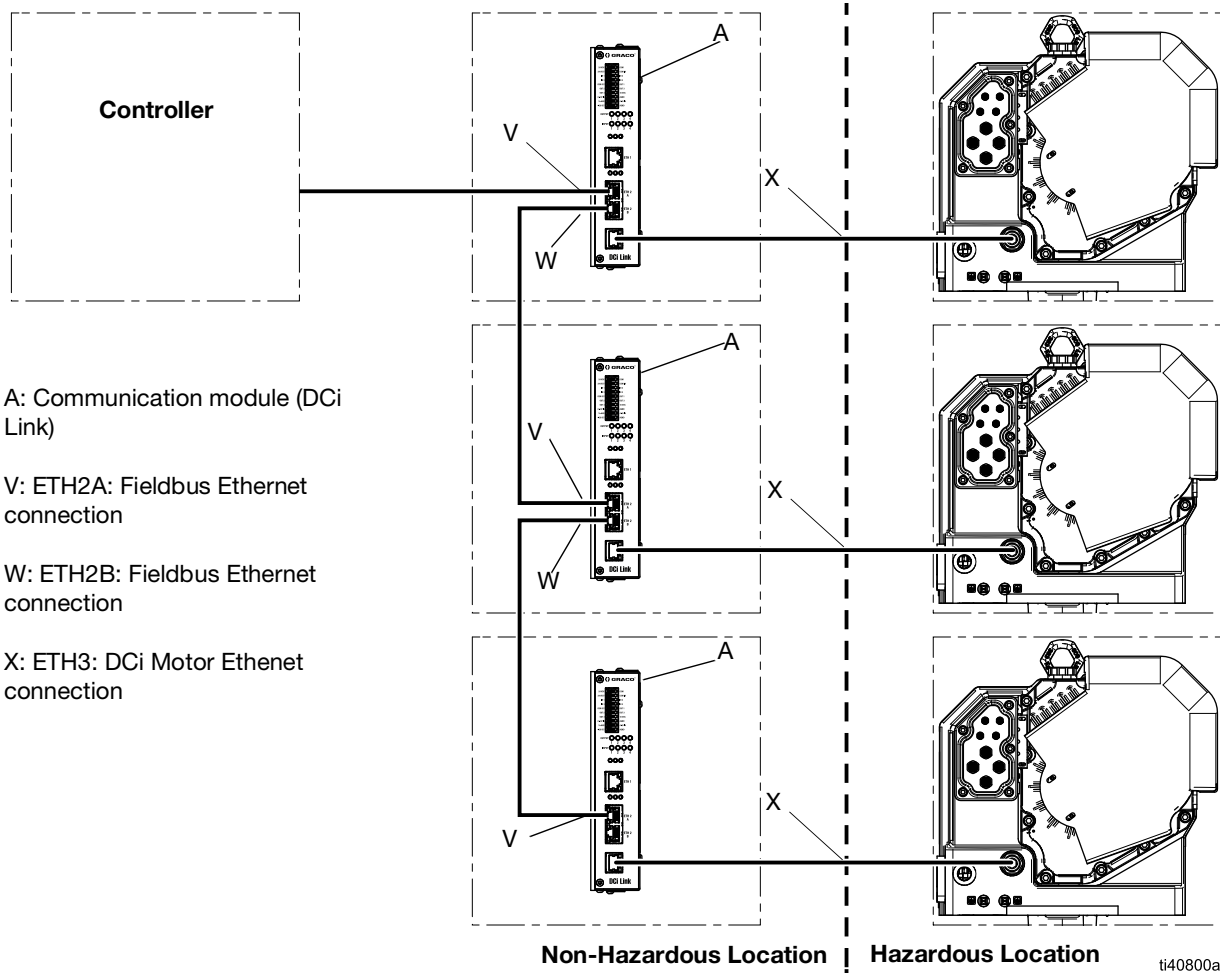
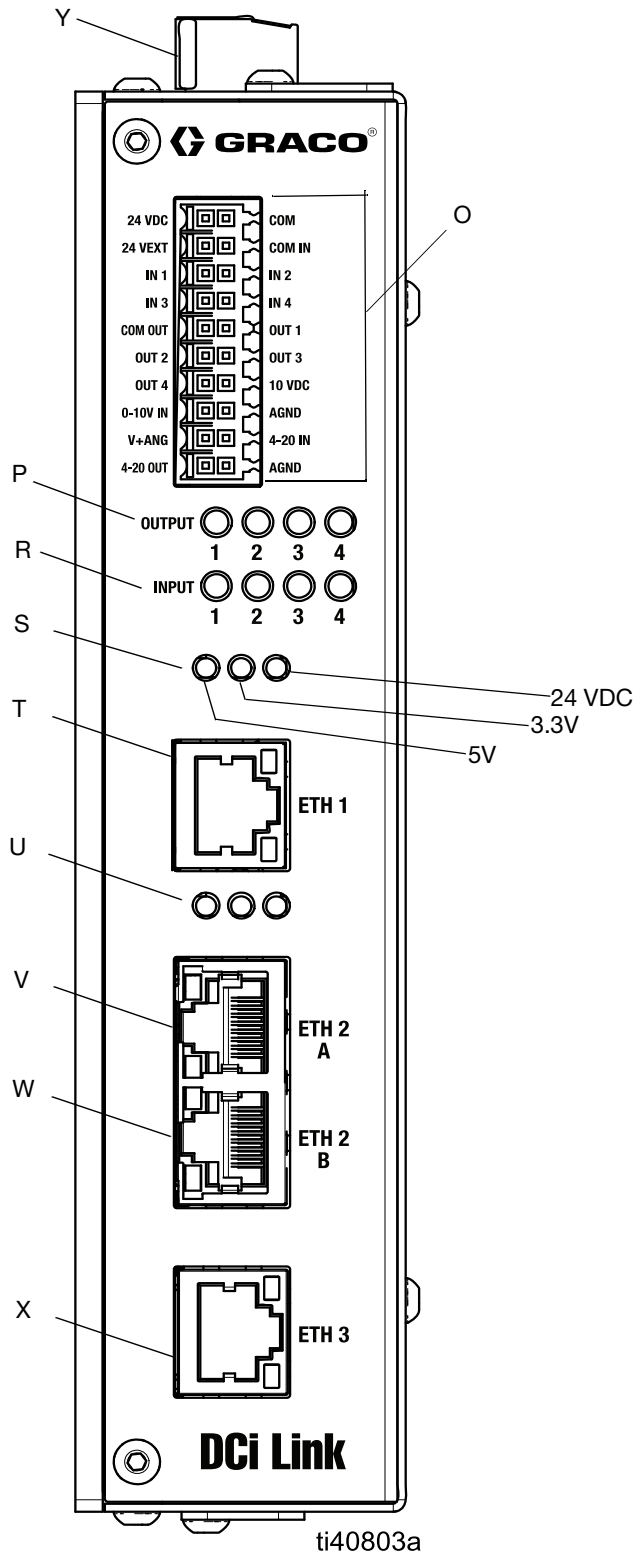

FIG. 9: Daisy chain installation

Component Identification



Key:

- O **Input/Output Connections:** See **I/O Wiring**, page 14.
- P **Digital Output Status LEDs:** indicates the digital output is active.
- R **Digital Input Status LEDs:** indicates the digital input is active
- S **System Status LEDs:** See **System Status (S)**, page 13.
- T **ETH1:** Ethernet Configuration Interface port.
- U **Industrial Protocol LEDs:** See **Fieldbus LEDs**, page 19.
- V **ETH2A:** Fieldbus Ethernet connection port
- W **ETH2B:** Fieldbus Ethernet connection port
- X **ETH3:** DCi Motor Ethernet connection port
- Y **Power Input Connection** (on top of module): Connects to the power source. See **DC Power Source**, page 9.

LED Descriptions

System Status (S)

System status LEDs. The Power LED is on the left, and the other two LEDs are not used.

24 VDC Power Indicator

Color	State	Meaning
Green	On	24 VDC Power is Applied, Status is Good
---	Off	Power is Not Applied, Board Failure

FIG. 10: Front Connections

Setup

I/O Wiring

Use the FIG. 11 schematic to set up I/O connections.

Wire Size: 16-28 AWG (0.2-1.5 mm²)

1	24VDC	COM	2
3	24VEXT	COM IN	4
5	IN 1	IN 2	6
7	IN 3	IN 4	8
9	COM OUT	OUT 1	10
11	OUT 2	OUT 3	12
13	OUT 4	10VDC	14
15	0-10V IN	AGND	16
17	V+ ANG	4-20 IN	18
19	4-20 OUT	AGND	20

FIG. 11: Inputs and outputs schematic

Key:

- 1 **24VDC** - 24 VDC sourced by DCi Link, internally connected to 24VDC power input connection (Y)
- 2 **COM** - Common return for 24 VDC, internally connected to 24VDC power input connection (Y)
- 3 **24VEXT** - External 24 VDC input to power isolated circuits
- 4 **COM IN** - COM reference for digital inputs
- 5 **IN 1** - Digital Input 1
- 6 **IN 2** - Digital Input 2
- 7 **IN 3** - Digital Input 3
- 8 **IN 4** - Digital Input 4
- 9 **COM OUT** - COM reference for digital output
- 10 **OUT 1** - Digital Output 1
- 11 **OUT 2** - Digital Output 2
- 12 **OUT 3** - Digital Output 3
- 13 **OUT 4** - Digital Output 4
- 14 **10VDC** - 10 vDC source for 0-10 vDC input, Pin 15
- 15 **0-10V IN** - 0-10 V in analog input used to monitor the potentiometer
- 16 **AGND** - Analog ground reference
- 17 **V+ ANG** - 24 vDC source for 4-20 mA input, Pin 18
- 18 **4-20 IN** - 4-20 mA analog input, typically used for the Pump Outlet Pressure Transducer
- 19 **4-20 OUT** - 4-20 mA analog output, typically used for the Back Pressure Regulator
- 20 **AGND** - Analog ground reference

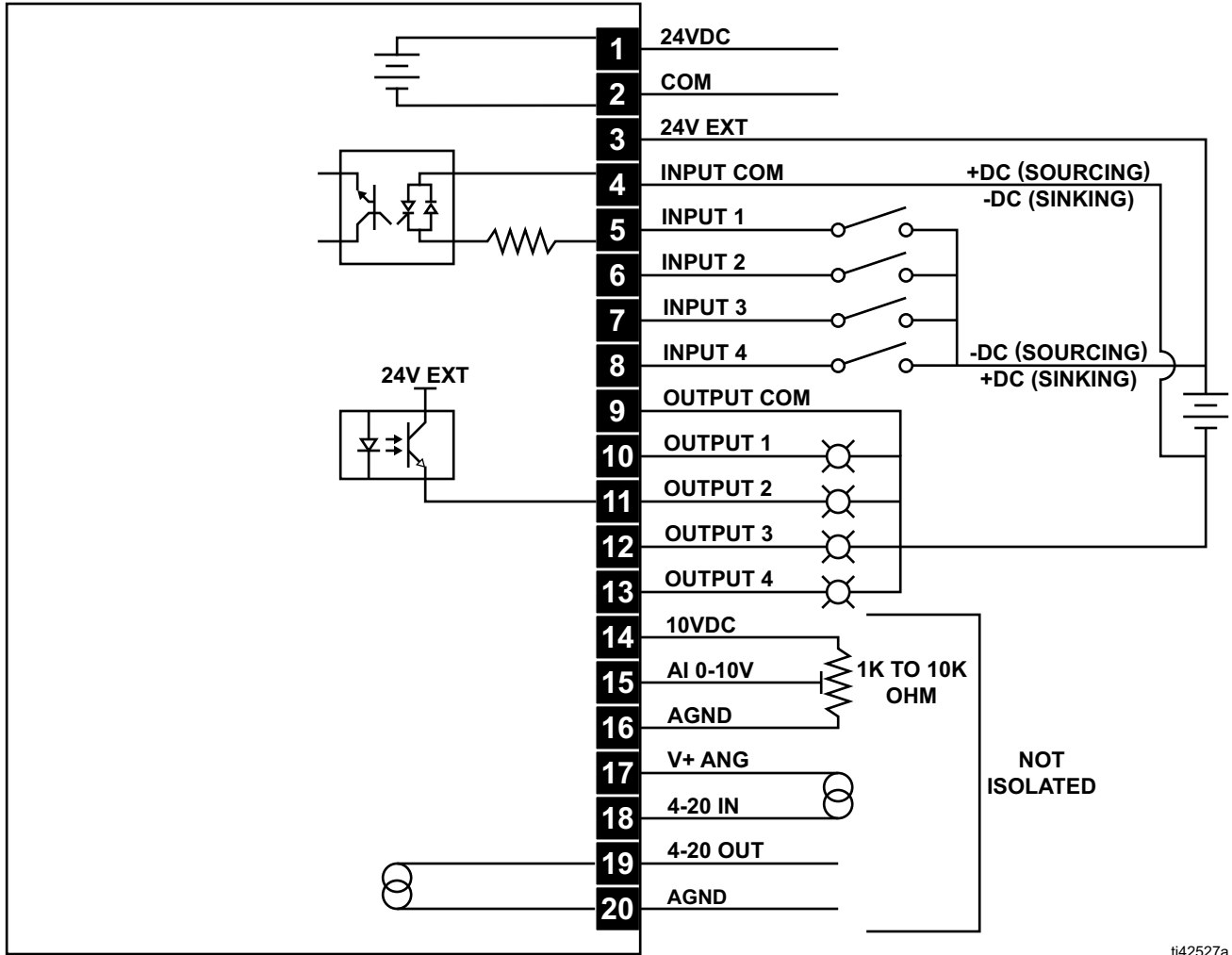

ti42527a

FIG. 12: Isolated Sinking I/O with External 24 vDC Power Supply

NOTE: Pins 1 and 2 are internally connected to 24VDC power input connection (Y).

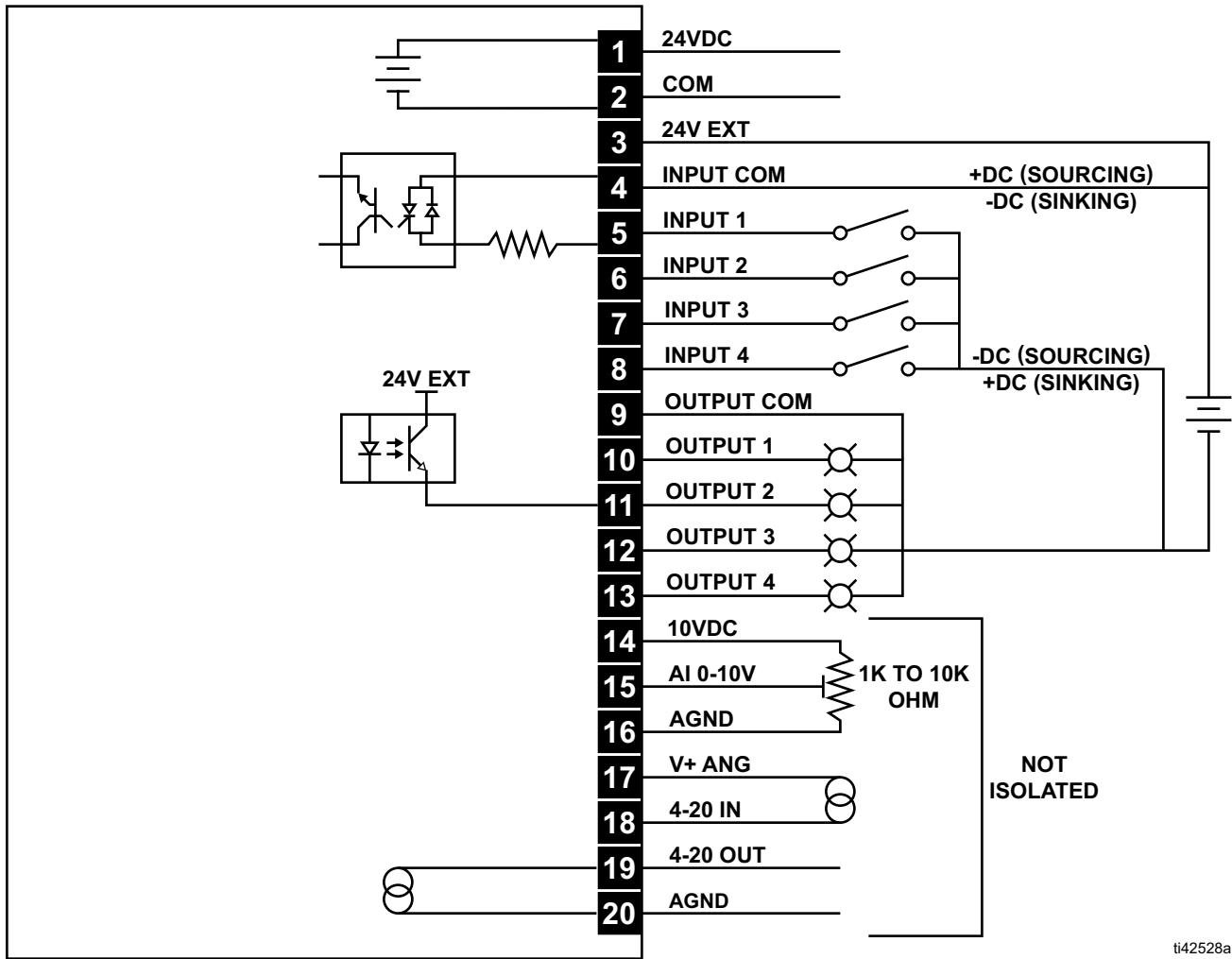

ti42528a

FIG. 13: Isolated Sourcing I/O with External 24 vDC Power Supply

NOTE: Pins 1 and 2 are internally connected to 24VDC power input connection (Y).

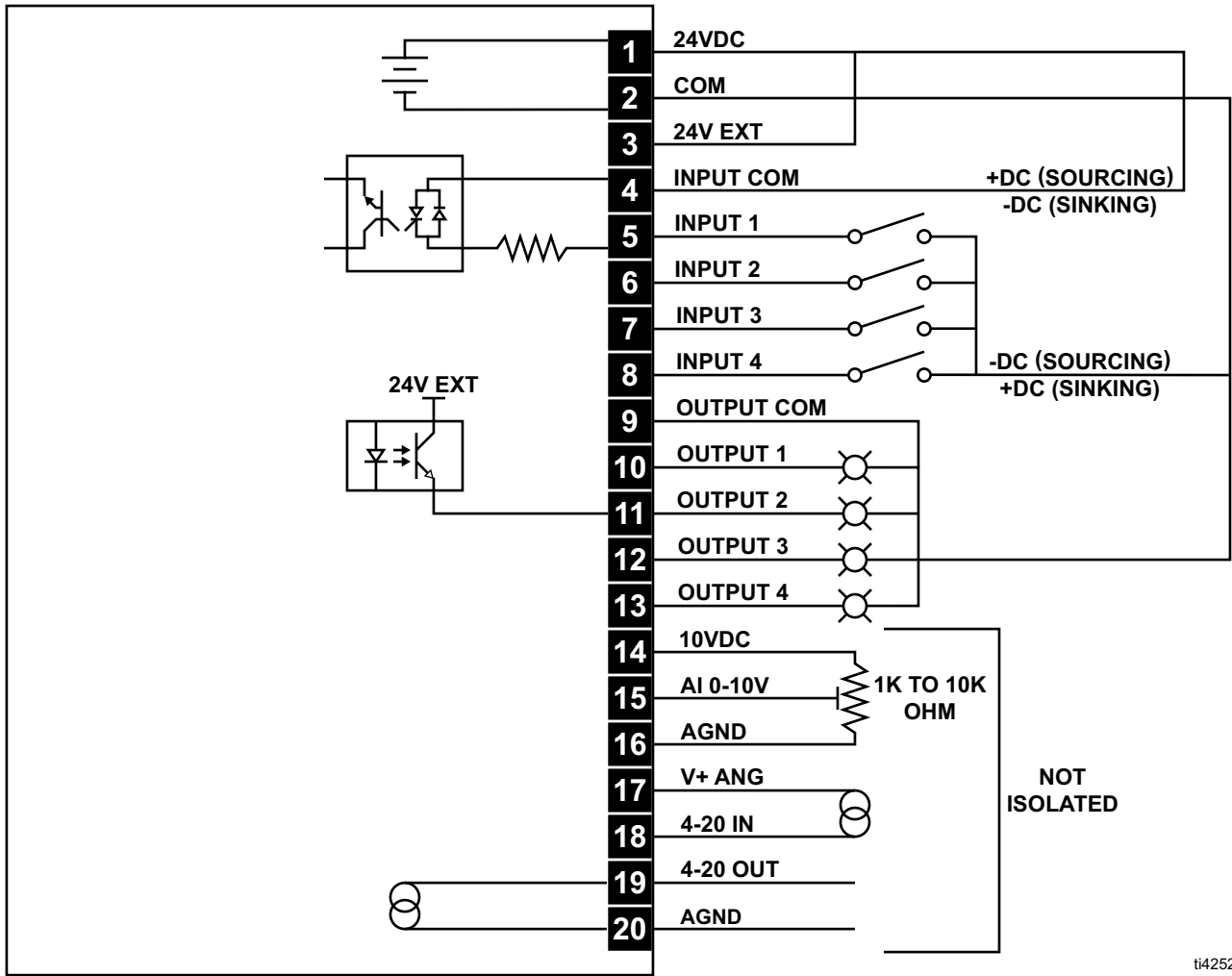

ti42529a

FIG. 14: Sourcing I/O with Internal 24 vDC Power Supply

NOTE: Pins 1 and 2 are internally connected to 24VDC power input connection (Y).

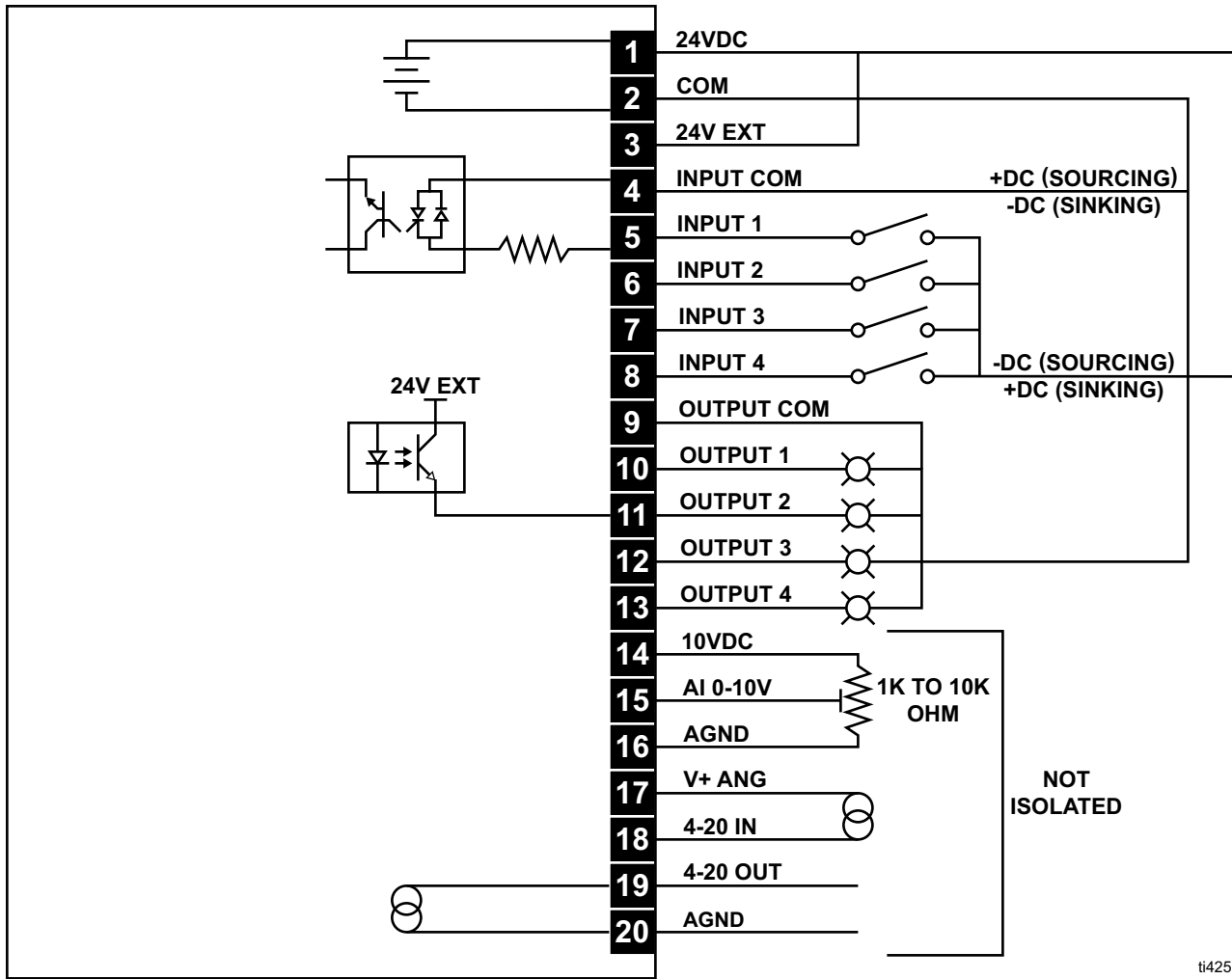

ti42530a

FIG. 15: Sinking I/O with Internal 24 vDC Power Supply

NOTE: Pins 1 and 2 are internally connected to 24VDC power input connection (Y).

Fieldbus Connections

Connect ETH2A (V) to the PLC with an Ethernet cable.

Optional: Connect ETH2B (W) to another module to daisy chain multiple modules together. See **Optional: Connect Multiple Modules**, page 12.

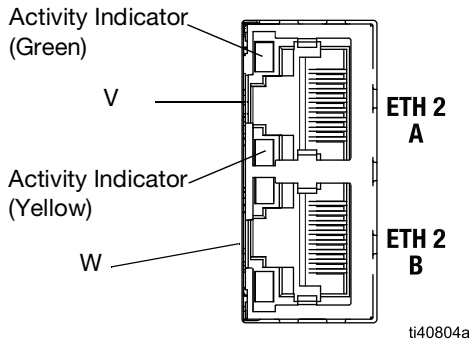

Fieldbus LEDs

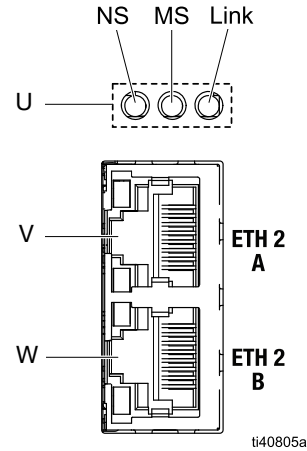

Fieldbus LEDs (U) are listed below from left to right, for both **EtherNet/IP**, page 19, and **PROFINET**, page 20.

EtherNet/IP

Network Status (NS)

State	Description
Off	No power or no IP address
Green	On-line, one or more connections established (CIP Class 1 or 3)
Flashing Green	On-line, no connections established
Red	Duplicate IP address, FATAL error
Flashing Red	One or more connections timed out (CIP Class 1 or 3)

Module Status (MS)

State	Description
Off	No power
Green	Controlled by a Scanner in Run state
Flashing Green	Not configured, or Scanner in Idle state
Red	Major fault (EXCEPTION-state, FATAL error etc.)
Flashing Red	Recoverable fault(s)

LINK/Activity (Link)

State	Description
Off	No link, no activity
Green	Link established
Flashing Green	Activity

PROFINET**Network Status (NS)**

State	Description	Comments
Off	Offline	- No power - No connection with IO Controller
Green	On-line, (RUN)	- Connection with IO Controller established - IO Controller with RUN state
Flashing Green	On-line, (STOP)	- Connection with IO Controller established - IO Controller in STOP state

Module Status (MS)

State	Description	Comments
Off	Not initialized	No power or module in "SETUP" or "NW_INIT" state
Green	Normal operation	Diagnostic event(s) present
Flashing Green	Initialized, diagnostic event(s) present	Used by engineering tools to identify node on network
Red	Exception error	Module in state "EXCEPTION"
Red (1 flash)	Configuration error	Expected Identification differs from Real Identification
Red (2 flashes)	IP Address not set	Set IP address via system monitor or DNS server
Red (3 flashes)	Station Name not set	Set Station Name via system monitor
Red (4 flashes)	Major Internal Error	Cycle system power; replace module

Link/Activity (Link)

State	Description
Off	No Link, no communication present
Green	Link established, no communication present
Green, flashing	Link established, communication present

Ethernet Connection

This port is used connect to the DCi Link web interface. This interface allows the user to monitor, control, and configure the E-Flo DCi motor.

1. Insert one end of an Ethernet cable (EC) into ETH 1 (T) port.

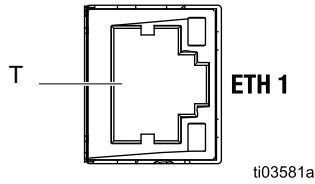

2. Insert the other end of the Ethernet cable into a computer with an updated operating system.

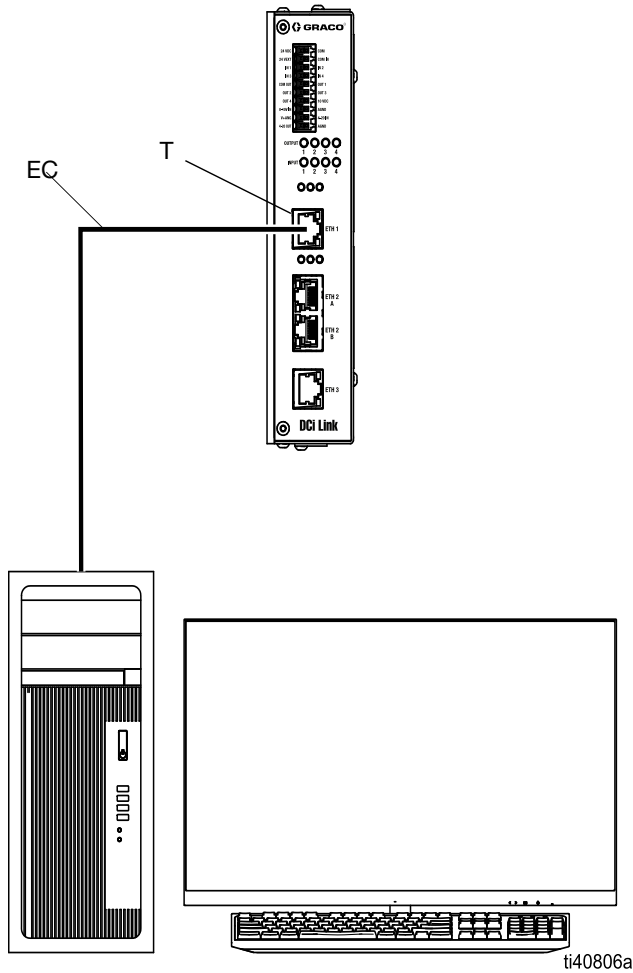

3. Follow the **IP Address Setup**, page 24.

Computer Configuration

Configure the connected computer to communicate with the control module. Procedures and screen captures may vary by operating system.

Connect to the User Interface

The user interface (HMI) is embedded into the controller as an internal web interface. A standard Internet browser application such as Microsoft Edge, Google Chrome, or Apple Safari, plus a wired connection, is all that is required to monitor and control the equipment.

NOTE: A standard Ethernet patch cable is recommended as the most reliable and permanent connection. The patch cable must be Cat 5E or better, and not exceed 90 m or 295 ft.

Networked Connection

Consult your local IT or OT network professional *before* connecting the device into any network or switch with other devices for detailed instructions.

Direct Connection

When directly connecting a PC to the equipment, reference the diagram as shown.

NOTE: Some PCs may require the use of an Ethernet Adapter accessory if the device not have an Ethernet port.

PC Settings	Graco Controller Settings - Port ETH-1
Manual IP Address: 192.168.178.xxx (cannot be the same as the DCi Link address)	Factory IP Address: 192.168.178.100
Subnet mask: 255.255.255.0	Subnet mask: 255.255.255.0

NOTE: The DCi Link is preconfigured for connection to port ETH-1. The controller has a static, or fixed, IP address of 192.168.178.100. This address can be changed using the web interface if required.

PC Connections

Windows 11:

The computer's Ethernet adapter must be configured properly to connect to the controller. Some settings may require Administrator Privileges; contact your IT professional for additional assistance as required.

1. From the Start menu, open **Settings** -> **Network & Internet** -> **Ethernet**.
2. Select the appropriate Ethernet connection.
3. Locate **IP Assignment** and select **Edit**.
4. Select **Manual**.
5. Enter the following for **IPv4**. Leave all other fields empty.
 - IP Address: 192.168.178.xxx
 - Subnet Mask: 255.255.255.0
6. Select **Save**.

Windows 10:

The computer's Ethernet adapter must be configured properly to connect to the controller. Some settings may require Administrator Privileges; contact your IT professional for additional assistance as required.

1. From the Start menu, open **Settings** -> **Network & Internet**.
2. Select the appropriate Ethernet connection and select **Properties**.
3. Locate **IP Assignment** and select **Edit**.
4. Select **Manual**.
5. Enter the following for **IPv4**. Leave all other fields empty.
 - IP Address: 192.168.178.xxx
 - Subnet Prefix: 24
 - Gateway: 192.168.1.1
6. Select **Save**.

Log into DCi Link

NOTE: If the user does not log in, the site considers them a viewer and they will have limited access to view-only information. See **User Types**, page 27.

1. On a device configured to communicate with DCi Link, open a browser.
2. In the address bar of the browser, enter the default IP address and port number for DCi Link: 192.168.178.100:8000.
3. To log in as a user, click the Login button in the DCi Link Interface, located in the upper right corner. The Login window displays.
 - If this the first login, you will be prompted to create a user. The default rights of that user will be Administrator.
4. Select a language and enter your username and password.
5. Click **Login**.

Web Interface Navigation

The following setup and connection procedures include steps that are taken within your computer’s settings, as well as within the DCi Link web interface.

- Computer navigation is explained within your computer’s user documentation.
- The web interface navigation is directed through the navigation panel (see FIG. 16) on the left side of the interface display.

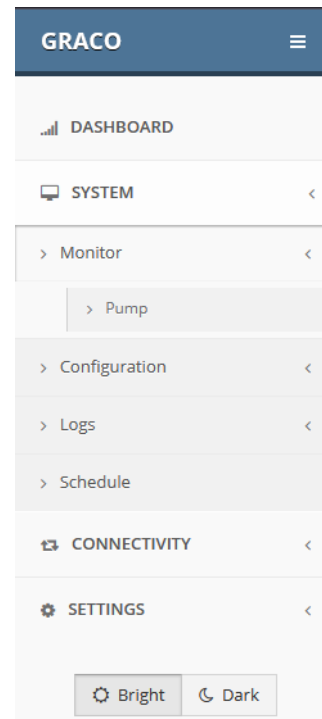

FIG. 16: Navigation Panel

Navigation directions start with one of the headings shown in FIG. 16 and is followed by any additional subheadings or buttons. For example, the navigation sequence to the Ethernet network configuration is described as **CONNECTIVITY > Interfaces > [Ethernet]**, where the square brackets ([...]) indicate a button selection. The navigation is also reflected in the breadcrumb at the top of the interface window.

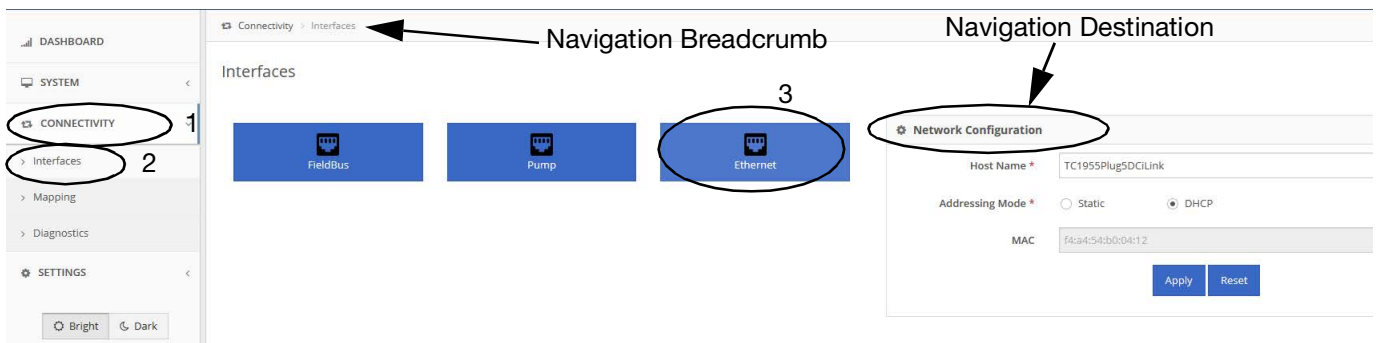

FIG. 17: Navigation Sequence

IP Address Setup

1. Follow the instructions in **2. Optional: Follow the instructions in Modify the IP Address, page 24, to update the IP settings.**, page 24.
2. **Optional:** Follow the instructions in **Modify the IP Address, page 24, to update the IP settings.**

Modify the IP Address

(CONNECTIVITY > Interfaces > [Ethernet])

Static Connection

1. Open the DCi Link web interface.
2. Navigate to the Interfaces page (**CONNECTIVITY > Interfaces**) and click **Ethernet** to display the *Network Configuration* form.

The screenshot shows the 'Network Configuration' form with the following fields and values:

- Host Name *: GracoDCiLink
- Addressing Mode *: Static DHCP
- MAC: f4:a4:54:b0:04:12
- IP Address *: Enter Ip Address
- Subnet Mask *: Enter Subnet Mask
- Gateway IP *: Enter Gateway Ip
- Preferred DNS server: Enter DNS Ip
- Alternate DNS server: Enter DNS Ip

Buttons: Apply, Reset

FIG. 18: Static Connection Network Configuration

3. Select **Static** in the **Addressing Mode** field and fill in the fields with the static IP address information.

NOTE: This IP address must be different from any other IP address used in the network.

4. Follow the instructions in **2. Optional: Follow the instructions in Modify the IP Address, page 24, to update the IP settings.**, page 24, and enter a matching static IP address.

DHCP Connection

DHCP (Dynamic Host Configuration Protocol) is a network management protocol used to automatically assign IP addresses and other network configuration details to devices on a network. This eliminates the need for manual IP configuration, making network management more efficient and reducing the likelihood of configuration errors.

By enabled DHCP, the DCi Link will attempt to acquire an IP address from the local DHCP server on the network.

It is recommended to assign a host name to the DCi Link to enable the user to access the device with this host name instead of the DHCP assigned IP address.

The user will then have to obtain the IP address assigned from the local IT department, or use the host name that was assigned to access the DCi Link interface.

If the DHCP request fails, the unit will have a fall back IP address of 192.168.178.100:8000. Timeout defaults to 30 seconds for the initial request, and will continue to try in the background.

User Management

(SETTINGS > User Management)

Select **SETTINGS > User Management** from the navigation panel to display the *User Management* page and a list of existing users.

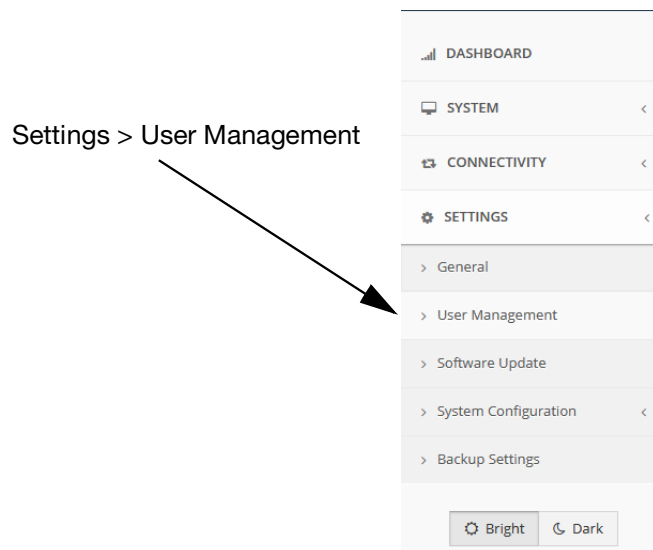

FIG. 19: Navigation Panel to User Management

Adding, editing, and deleting users is done from the *User Management* page. FIG. 20 shows a table with name, username, password, email, expiry date, language, and user type.

- To create users, following the procedure in **Create User**, page 26.
- To edit existing users, click the edit icon in the user's **Action** column to display the *Add User* form. Edit the *Add User* form fields as described in **Create User**, page 26, and click **Update**.

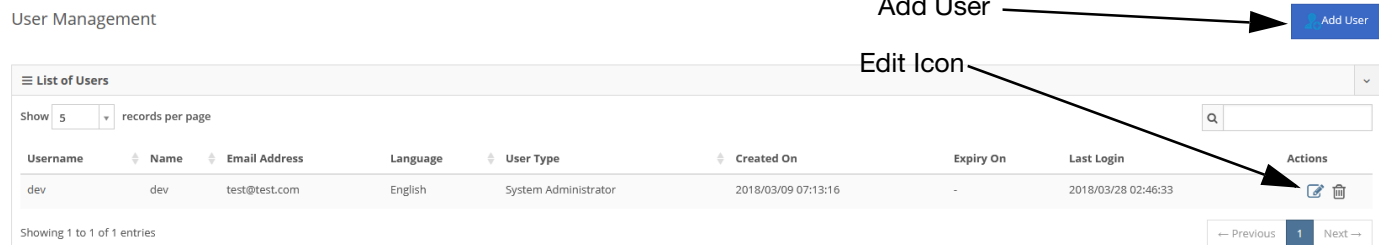

FIG. 20: User Management Page

Create User

(*SETTINGS > User Management > [Add User]*)

1. Click the **Add User** button to display the *Add User* form.
2. Complete all of the fields on the *Add User* form. Click on the **Language** and **User Type** fields for a list of available options. User types are described in **User Types**, page 27.

The screenshot shows the 'Add User' form with the following fields and options:

- Name***: Text input field with placeholder 'Enter name'.
- Username***: Text input field with placeholder 'Enter username'.
- Password***: Text input field with placeholder 'Enter password'.
- Confirm password***: Text input field with placeholder 'Confirm password'.
- Email***: Text input field with placeholder 'Enter email'.
- Expiry Mode***: Radio button for 'Never Expire' (selected), radio button for 'Add Expiry Date', and a date input field with placeholder 'YYYY/MM/DD'.
- Language***: Dropdown menu with 'English' selected.
- User Type***: Dropdown menu with 'Operator' selected.

At the bottom right, there are three buttons: 'Add', 'Clear', and 'Cancel'.

FIG. 21: Add User Page

NOTE: Use the **Expiry Mode** field to indicate whether the user type permissions have an expiration date, and what that date would be if the permissions did expire.

3. After completing all of the fields, click **Add** to close the form and add the new user to the *List of Users* table, or click **Cancel** to close the form without saving the fields.

User Types

The system has multiple user types with various levels of permissions to allow several users to perform their daily tasks while still protecting the system from improper operation.

The system is view-only by default. Anybody can access the web interface and view the system operation parameters and status.

NOTE: System Administrator is the default user type when the first user is created.

	Operator	Maintenance	Supervisor	System Administrator
Rights	Day-to-day user tasked with ensuring production stays on track and is operating as desired.	Performs scheduled or emergency maintenance, such as clearing maintenance counters on the pumps and changing operating modes to flush or jog the motor for pump change outs.	The line manager, cell manager, or plant manager. Has rights to the entire system except System Configuration, which contains the networking configurations for Email and Secure Shell.	Has full rights to the system to commission the product and set up necessary networking configurations. Has the same rights as the Supervisor, and has access to SMTP and SSL configuration for the network.
Enable/Disable Production Mode	✓	✓	✓	✓
Enable/Disable Pump	✓	✓	✓	✓
Clear Event	✓	✓	✓	✓
Modify Active Profile	✓	✓	✓	✓
Clear Maintenance Counter		✓	✓	✓
Station and Pump Configuration			✓	✓
Fieldbus			✓	✓
Ethernet			✓	✓
User Management			✓	✓
Software updates			✓	✓
System Configuration				✓

System Configuration

(SYSTEM > Configuration)

Select **SYSTEM > Configuration** from the navigation panel to display the *System Configuration* page.

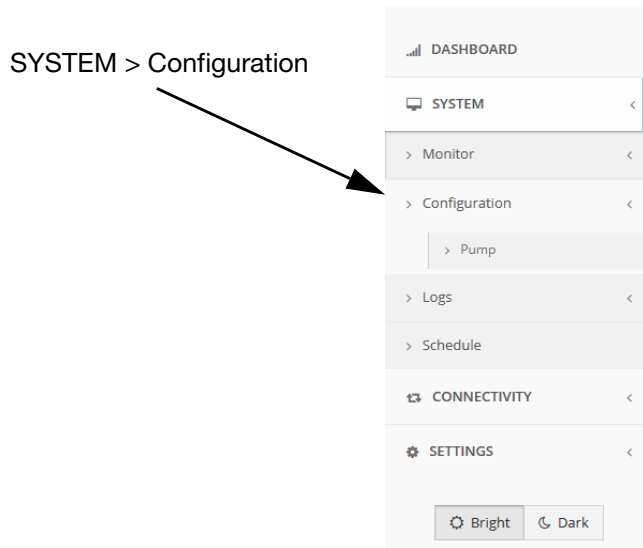

FIG. 22: Navigation Panel to System Configuration

Use the *System Configuration* page and tabs to configure the;

- **System**, page 29
- **Units**, page 30
- **Display**, page 31; includes the system overview and dashboard displays
- **Digital Input**, page 33, and **Digital Output**, page 35
- **Analog Input**, page 36, and **Analog Output**, page 38.

System

(*SYSTEM* > *Configuration* > [*System*])

System > Configuration

System Configuration

System Units Display Digital Input Digital Output Analog Input Analog Output

System

Station Name Graco Blue

Maintain Back Pressure OFF

Apply

FIG. 23: System Configuration Page

Station Name

Allows user to provide a custom name to DCi Link that appears in the title bar at the top of the web interface.

Maintain Back Pressure

DCi Link maintains a 4-20 mA signal to the I2P when the pump is off to maintain pneumatic pressure at the back pressure regulator (BPR).

- ON - DCi Link maintains a 4-20 mA output when the pump is off.
- OFF - DCi Link's 4-20 mA output goes to 4 mA, which drops the BPR pressure.

Units

(SYSTEM > Configuration > [Units])

Establishes units used throughout the interface for pressure, volume, and flow.

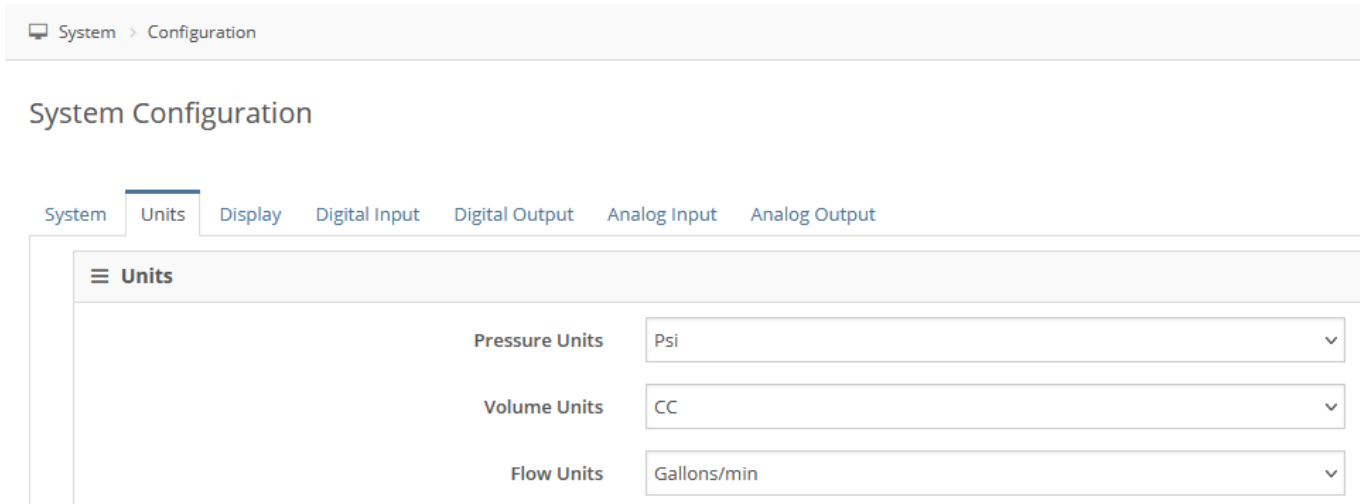

FIG. 24: Units Detail Configuration Page

Pressure Units

Available pressure units:

- Psi
- **bar** (default)
- MPa

Volume Units

Available volume units:

- Gallons
- **Liters** (default)
- CC

Flow Units

Available flow units:

- Gallons/min
- **Liters/min** (default)
- cc/min
- oz/min
- cycle/min

Display

(SYSTEM > Configuration > [Display])

Determines what information is displayed on the *System Overview* page and *Dashboard*.

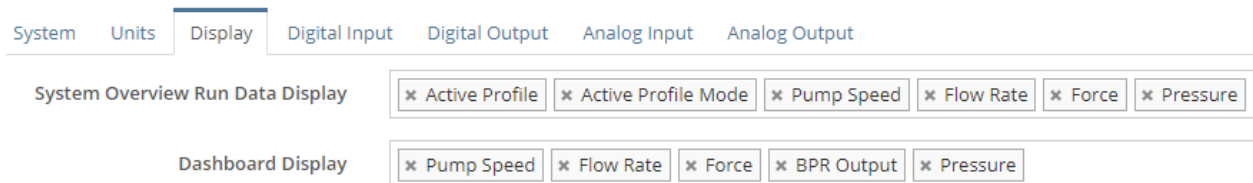

FIG. 25: Display Detail Configuration Page

System Overview Run Data Display

(SYSTEM)

The selections made in this field appear on the *System Overview* page, as circled in FIG. 26. A maximum of six items can be selected for display. Until six items are selected, click in the **System Overview Run Data Display** field to see a list of available options. If six items are already selected, one of the items must be removed before selecting another item.

To remove an item, click the “x” in the item’s box.

System Overview

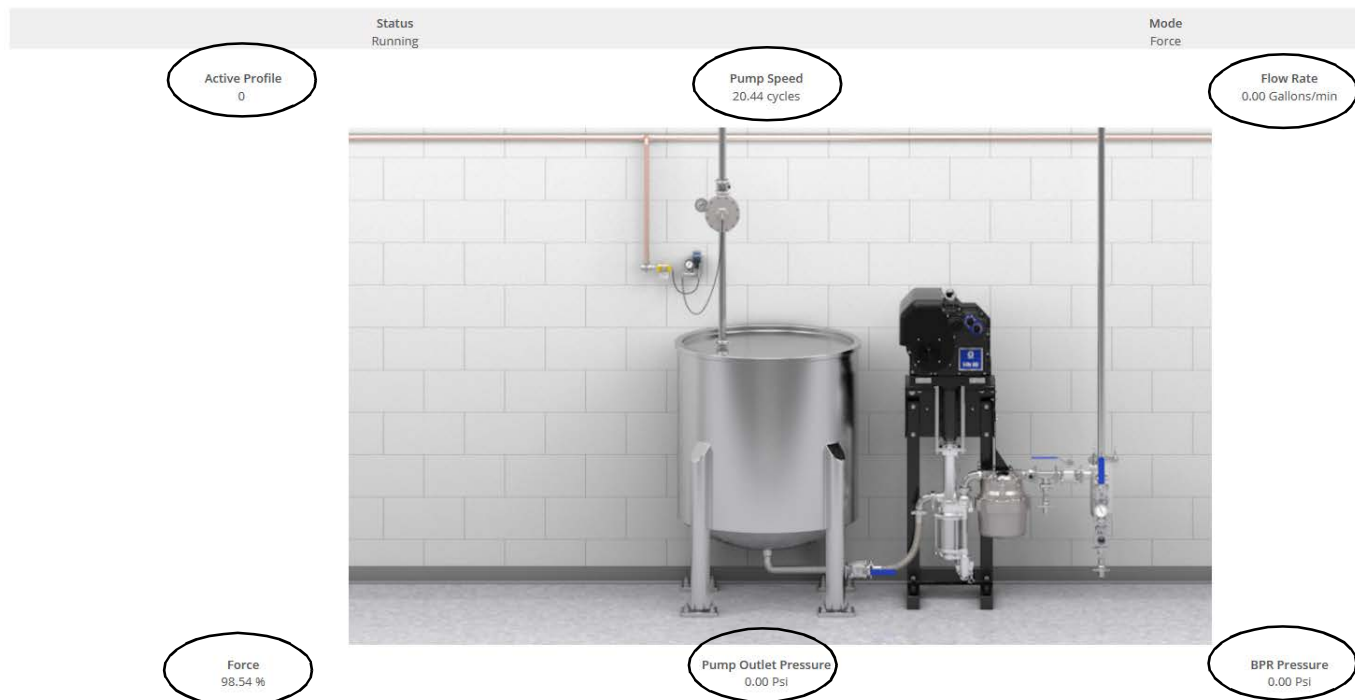

FIG. 26: System Overview Run Data Display

Dashboard Display

(DASHBOARD)

The selections made in this field appear on the *Dashboard*, as circled in FIG. 27. Click in the **Dashboard Display** field to see a list of available options.

To remove an item, click the “x” in the item’s box.

Dashboard



FIG. 27: Dashboard Display

Digital Input

(SYSTEM > Configuration > [Digital Input])

NOTE: If using an E-Flo DCi Advanced motor, the Digital Inputs can be enabled and configured through either the *System Configuration* page, or through the *Pump* page. Configuring the digital inputs on either page will result in the same functionality. However, once this feature is enabled, it can only be replicated or configured on the other device. There will be an indicator explaining where the feature has already been enabled.

System Configuration

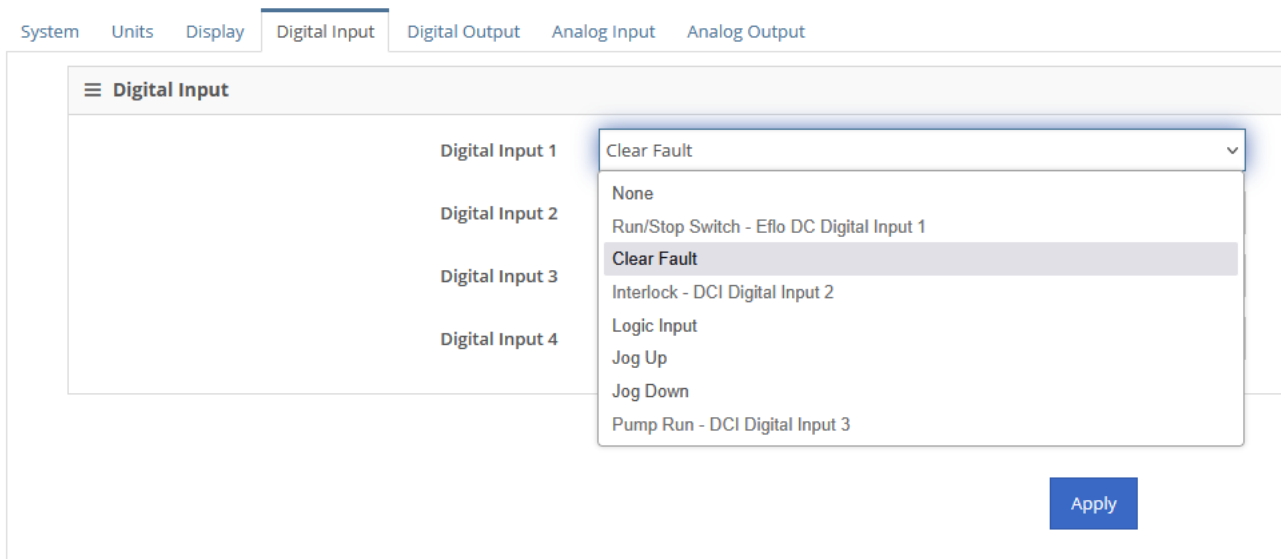

FIG. 28: Digital Input

Run/Stop Switch

Run/Stop switches pause pump operation at the station while the user performs a local operation around the station.

Input Value	Operation Mode	Description
0	Run (0 VDC)	The pump resumes operation when the switch is put into the Run position.
1	Stop (24 VDC)	The pump pauses operation when the switch is put into the Stop position.

Clear Event

Clears all active events on the pump, allowing the local operator to resume pump operation.

Input Value	Operation Mode	Description
0	N/A (0 VDC)	Does nothing.
1	Clear (24 VDC)	Clear all active events.

Interlock

Stops the pump when the interlock is active. The pump remains stopped even after the interlock event is deactivated. The pump must be reenabled (via Pump Run, the fieldbus, or the web interface) to resume operation.

Input Value	Operation Mode	Description
0	N/A (0 VDC)	The interlock event is cleared.
1	Stop (24 VDC)	Pump operation is stopped and cannot resume until the interlock is cleared.

Logic Input

Programmable Logic Control (PLC) reads the status of the DCi Link input to take specific action. The input is used as a remote bit to the Fieldbus controller; there is no direct operation for the DCi pump.

Input Value	Operation Mode	Description
0	Not Active (0 VDC)	Input is not active.
1	Active (24 VDC)	Input is active.

Jog Up

The motor exits Run mode and slowly jogs the motor shaft until it is fully retracted and then automatically goes to Off mode when the topmost position is detected. If the switch is returned to the Stop position before the motor shaft reaches the topmost position, the motor stops at its current position.

Input Value	Operation Mode	Description
0	N/A (0 VDC)	---
1	Jog Up (24 VDC)	The pump shaft moves to the uppermost position.

Jog Down

The motor exits Run mode and slowly jogs the motor shaft until it is fully extended and then automatically goes to Off mode when the bottommost position is detected. If the switch is returned to the Stop position before the motor shaft reaches the bottommost position, the motor stops at its current position.

Input Value	Operation Mode	Description
0	N/A (0 VDC)	---
1	Jog Down (24 VDC)	The pump shaft moves to the lowermost position.

Pump Run

Input Value	Operation Mode	Description
0	N/A (0 VDC)	Does nothing
1	Start Pump (24 VDC)	The pump will resume operation if no event prevents the pump from running

Digital Output

(SYSTEM > Configuration > [Digital Output])

NOTE: If using an E-Flo DCi Advanced motor, the Digital Outputs can be enabled and configured through either the *System Configuration* page, or through the *Pump* page. Configuring the digital outputs on either page will result in the same functionality. However, once this feature is enabled, it can only be replicated or configured on the other device. There will be an indicator explaining where the feature has already been enabled.

System Configuration

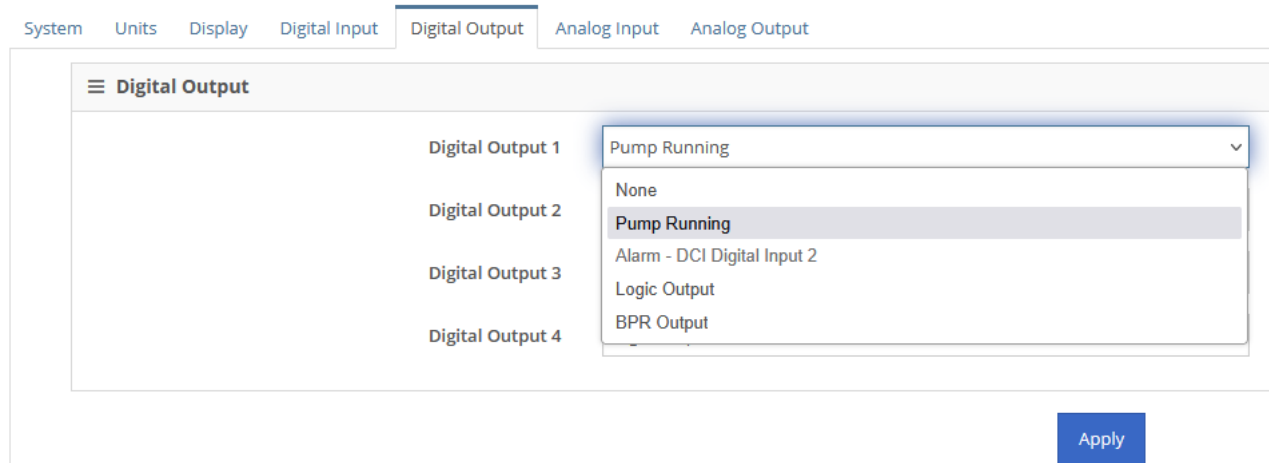

FIG. 29: Digital Output

Pump Running

Output is active while the motor is in Run mode. Output remains active even when the motor is stalled. Typical use is to connect the output to a light to indicate operation.

Output Value	Operation Mode	Description
0	Pump Not Active (0 VDC)	The pump is currently off.
1	Pump Active (24 VDC)	The pump is active and applying force.

Alarm

Output is active while the motor has an active alarm. Typical use is to connect the output to a light to indicate an alarm is active.

Output Value	Operation Mode	Description
0	Inactive Alarm (0 VDC)	No alarm is present.
1	Active Alarm (24 VDC)	An alarm has occurred and has not been cleared.

Logic Output

Logic output is driven by a Programmable Logic Controller (PLC) over a fieldbus to activate or deactivate output to drive local output near the manufacturing line. Logical Output is a sourcing output, see FIG. 12 to FIG. 15 (based on preferred wiring) for wiring and specifications.

Output Value	Operation Mode	Description
0	Not Active (0 VDC)	Does nothing.
1	Active (24 VDC)	The system applies 24 VDC to digital output.

Analog Input

(SYSTEM > Configuration > [Analog Input])

NOTE: If using an E-Flo DCi Advanced motor, the Analog Inputs can be enabled and configured through either the *System Configuration* page, or through the *Pump* page. Configuring the analog inputs on either page will result in the same functionality. However, once this feature is enabled, it can only be replicated or configured on the other device. There will be an indicator explaining where the feature has already been enabled.

System Configuration

The screenshot shows the 'System Configuration' interface with the 'Analog Input' tab selected. The interface is divided into two main sections for different input ranges:

- 4 to 20 mA:** This section is currently enabled, indicated by a green checkmark in the 'Enable' field. The 'Function' dropdown menu is open, showing three options: 'None', 'Pump Outlet Pressure', and 'BPR Pressure'. The '0% Value' is set to 'None' and the '100% Value' is set to 'Psi'.
- 0 to 10v:** This section is currently disabled, indicated by a red 'x' in the 'Enable' field. The '0-10V Input Sensor' dropdown menu is set to 'Select'.

An 'Apply' button is located at the bottom right of the configuration area.

FIG. 30: Analog Input

System Configuration

System Units Display Digital Input Digital Output **Analog Input** Analog Output

4 to 20 mA

Enable

Function None

0% Value 0.00 bar

100% Value 0.00 bar

0 to 10v

Enable

0-10V Input Sensor Select

Select

Flow Rate

Force

Pressure

Apply

FIG. 31: Analog Voltage Input**4 to 20 mA Input**

The 4-20 mA input is used to monitor system pressure. The user is required to enter the 0% and 100% process values for the sensor. This allows the system to convert from analog values to process values, assuming a linear line between these two points.

0% Value

To convert the 4-20 mA input to a process value, the user is required to enter a 0% value for the sensor. The system converts 4 mA to this value. This value specifies the zero (0) value.

100% Value

To convert the 4-20 mA input to a process value, the user is required to enter a 100% value for the sensor. The system converts 20 mA to this value. This value specifies the maximum value.

0 to 10 V Input

NOTE: This feature is not supported if using an E-Flo DCi Advanced motor.

The 0-10 V input is used to convert a potentiometer knob to a target flow rate or force command. The user is required to select the purpose of the 0-10 V knob: Flow or Force. The system converts 0-10 V to 0-100% of the target.

Analog Output

(SYSTEM > Configuration > [Analog Output])

NOTE: If using an E-Flo DCi Advanced motor, the Analog Outputs can be enabled and configured through either the *System Configuration* page, or through the *Pump* page. Configuring the analog outputs on either page will result in the same functionality. However, once this feature is enabled, it can only be replicated or configured on the other device. There will be an indicator explaining where the feature has already been enabled.

System Configuration

The screenshot shows the 'System Configuration' interface with the 'Analog Output' tab selected. The configuration is for the '4 to 20 mA' output. The 'Enable' checkbox is checked, and the 'Function' dropdown menu is open, showing 'None' as the selected option and 'Back Pressure Regulator' as an available option. An 'Apply' button is visible below the dropdown.

FIG. 32: Analog Output

4 to 20 mA

The 4-20 mA output is used to control a back pressure regulator and is linked to the active profile back pressure regulator value. The profile supports values 0-100% for a back pressure regulator. 0% is equal to a 4 mA output value, while 100% is equal to a 20 mA output value.

Pump Configuration

(**SYSTEM** > **Configuration** > **Pump**)

Select **SYSTEM** > **Configuration** > **Pump** from the navigation panel to display the *Pump* page.

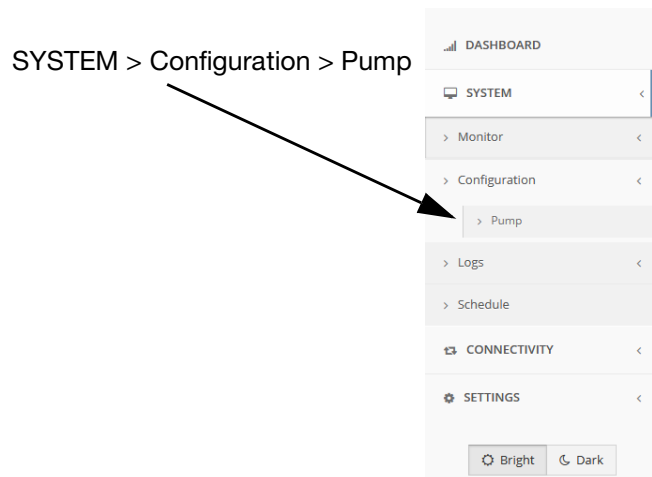

Fig. 33: Navigation Panel to Pump Configuration

Use the *Pump* page and tabs to;

- Set up the pump (**Setup**, page 40)
- Configure up to five pump profiles (**Profile**, page 41)
- Manage pump maintenance schedules (**Maintenance**, page 44).

When using an E-Flo DCi Advanced motor and using the following features at the pump, the user must configure them using the System > Configuration > Pump I/O tabs. These table will not appear for a basic motor.

- **Digital Input**, page 45, and **Digital Output**, page 47
- **Analog Input**, page 48, and **Analog Output**, page 49.
- **Temperature**, page 50.

Setup

(SYSTEM > Configuration > Pump > [Setup])

The **Setup** tab defines the most general parameters for your pump configuration. Review and change the settings in the following fields and click **Apply** to save your changes.

The screenshot shows the 'Setup' configuration page for a pump. It contains several settings:

- Lower Size:** A dropdown menu set to 'Custom' and a numeric input field set to '0', followed by the unit 'cc'.
- Remote Control:** A checkbox that is disabled (grayed out).
- Remote Start:** A checkbox that is checked (green).
- Auto Restart:** A checkbox that is disabled (grayed out).
- Communication Loss Alarm:** A checkbox that is disabled (grayed out).
- Date and Time:** Two input fields showing '2000/01/11' and '09:25:41 PM'.
- Software Version:** A text field containing '1.3.86'.
- Software Part Number:** A text field containing '19Y601'.

An 'Apply' button is located at the bottom center of the form.

FIG. 34: Pump Setup Form

System Type

This field indicates the system type. Only single pump systems are currently supported.

Lower Size

Use this field to set the lower pump size (cc) of the pump. The default is blank; select the correct lower size, or **Custom**. If **Custom** is selected, enter the size of the lower in cc.

Remote Control

The Remote Control field indicates whether the pump is operating in local mode (controlled by knobs) or remote mode (controlled by the PLC or Web interface). The operating mode is determined by adjusting the motor knobs (N) on the pump. For remote control to be enabled, the motor knob (N) on the pump must be turned to remote mode. See the E-Flo DCi Motor Installation-Operation manual. See **Related Manuals**, page 2.

NOTE: When the Remote Control field is disabled, all configurable pump fields will be disabled or grayed out.

Remote Start

Use this field to disable the ability to start the pump from a remote location using a fieldbus.

When disabled, the pump can only be started or stopped with the local Run/Stop Switch. If the pump is paused and this feature is enabled, the Run/Stop Switch must be toggled to activate the pump. See **Digital Input**, page 33, for information on configuring the Run/Stop Switch.

Auto Restart

When this field is enabled, the pump will resume operation after a power cycle. The unit will resume operation with the parameters from the profile that was last used before power was lost. If profile 0 was used, the pump will start with 0 as its target and wait for a commanded value from the web interface or fieldbus.

Communication Loss Alarm

Use this field to trigger an alarm any time communication between the pump and the fieldbus is lost. The pump will stop operation when the communication loss alarm is triggered.

Click **Apply** to save your selections.

Date and Time

Use this field to set your pump's date and time. Click the date and time link to display a window with a calendar and fields for hours and minutes. Select the current date in the calendar and the current hours and minutes, as well as whether the time is AM or PM.

Profile

(SYSTEM > Configuration > Pump > [Setup])

A profile is a set of operating conditions that the pump uses when in run mode. The DCi Link offers five profiles. Profile 0 is defined as the dynamic profile and the other four profiles (1-4) are referred to as fixed profiles.

The screenshot shows the 'Profile' configuration page. At the top, there are navigation tabs: Setup, Profile, Maintenance, Digital Input, Digital Output, Analog Input, Analog Output, and Temperature. The 'Production' status is set to 'ON' with a dropdown menu. Below this is a table of profiles:

Profile	Force(%)	Pressure Pump(Psi)	Flow Rate(Gallons/min)	Back Pressure Regulator(%)	Mode	Configure
0	100.00	2000.00	0.78	0	Force	✓ ✗
1	0.00	0.00	1.92	20	Pressure	✎
2	85.00	0.00	0.00	30	Force	✎
3	0.00	3000.00	0.00	25	Pressure	✎
4	0.00	0.00	0.00	0	Pressure	✎

To the right of the table is a detailed configuration panel for 'Profile 0'. It includes the following settings:

- Low Force Threshold: 0.00 %
- Low Force Event: Deviation
- High Force Threshold: 100.00 %
- High Force Event: Limit
- Low Flow Threshold: 0.00 Gallons/min
- Low Flow Event: Deviation
- High Flow Threshold: 1.92 Gallons/min
- High Flow Event: Limit
- Low Pressure Threshold: 0.00 Psi
- Low Pressure Event: Deviation
- High Pressure Threshold: 0.00 Psi
- High Pressure Event: Limit

Fig. 35: Pump Profile Form

A dynamic profile allows modification of operation targets with only operator user access over the web interface or over fieldbus. When using a dynamic profile, the system is required to enter all the operating values in order to get the pump to begin proper operation.

Fixed profiles are locked profiles, and user privileges are required to make modifications. The pump stores these values in non-volatile memory, and will be kept through a power cycle. This type of profile is used when a user wants to protect control of their process while requiring a high level of user rights to modify the values. The system is only required to select which profile to use as the active profile and the system will begin operation.

Clicking on a profile's row displays a window with the *Event Settings* for that profile. The *Event Settings* fields depend on whether a profile has a Mode set for Force,

Pressure, or Flow. Force event fields are: Low Force Threshold, Low Force Event, High Force Threshold, and High Force Event. Flow event fields are: Low Flow Threshold, Low Flow Event, High Flow Threshold, and High Flow Event. Pressure event fields are: Low Pressure Threshold, Low Pressure Event, High Pressure Threshold, and High Pressure Event.

Profile Number (0-4)

Indicates the profile number that the user is modifying.

Force (%)

Force target is required when the mode of operation is selected as "Force". The force value is a value of 0-100% of the pumps capability. The force will vary based on the pump type. See pump manuals for pressure vs flow rate curves. See **Related Manuals**, page 2.

Pressure (psi, bar, MPa)

NOTE: This feature is only supported if using an E-Flo DCi Advanced motor.

Pressure target is required when the mode of operation is selected as “Pressure”. The user is required to have a pressure sensor installed in port 7 of the DCi Motor, and configured for closed loop pressure. See **Installation**, page 8, and **Analog Input**, page 36.

The pressure target will be specified in user units selected in the **(SYSTEM > Configuration > [Units])** screen, shown on page 30. Maximum Pressure is set to 5000 PSI (345 bar). Ensure the proper pressure sensor is installed that can handle the output pressure of the pump. Verify the maximum pump pressure in the pump manual. See **Related Manuals**, page 2.

When in pressure mode, the pump will control to output a consistent fluid pressure at the outlet of the pump.

Flow Rate (gallon/min, cc/min, oz/min, cycles/min)

Flow Rate target is required when the mode of operation is selected as “Flow”. The flow rate target will be specified in user units selected in the **(SYSTEM > Configuration > [Units])** screen, shown on page 30. Maximum flow rate is determined by the pumps lower size. The user is required to populate the Pump->Setup lower size to match the pump that they are configuring.

Back Pressure Regulator (%)

Set BPR % closed when the profile is active. This is linked to 4-20 mA output on the DCi Link or an E-Flo DCi Advanced motor (port 6). See SYSTEM > Configuration > [Analog Output] when the DCi Link is controlling the BPR (basic or advanced). See PUMP > Configuration > [Analog Output] when the pump is controlling the BPR (advanced only). The user will be prevented from selecting this feature if it is already configured. 4 mA is equal to 0% (fully open), and 20 mA is equal to 100% (fully closed).

Profile Mode

Force

When Force mode is selected, the unit will operate on the force set point with a flow rate limited by the maximum High Flow Threshold. By default, the High Flow Threshold will be the maximum flow rate of the lower size selected.

Pressure

When Pressure mode is selected, the unit will operate on the pressure target with flow rate and force limited by the High Pressure Threshold specified in the profile. By default, the High Pressure Threshold is 100%.

Flow

When Flow mode is selected, the unit will operate on the flow set point with a force limited by the maximum High Force Threshold. By default, the High Force Threshold is 100%.

Thresholds/Events

Low Force Threshold

This field is always active and is used to capture an event when the pump force drops below the specified value. This can happen if the pump reaches its maximum flow and can't maintain force. This would capture a runaway event such as an empty tank/drum or a ruptured hose. The default value is 0%.

This field can have three different event types:

- **Limit (default):** Limits the minimum force the motor can generate.
NOTE: This option is disabled when pump is in Force mode.
- **Deviation:** Generates a deviation event when the motor force drops below the limit.
- **Alarm:** Generates an alarm and shuts down the pump when the fluid pressure limit is exceeded.

High Force Threshold

This field is active when profile is in Flow mode. Field is disabled when profile is in Force mode. The default value is 100%.

This field can have three different event types:

- **Limit (default):** Limits the maximum force the pump can generate.
- **Deviation:** Generates a deviation event when the pump force exceeds the limit.
- **Alarm:** Generates an alarm and shuts down the pump when the limit is exceeded.

Low Flow Threshold (gallon/min, cc/min, oz/min, cycles/min)

This field is always active and is used to capture an event when the pump flow rate drops below the specified value. This can happen if the pump reaches its maximum force and can't maintain flow rate. The default value is 0%.

This field can have three different event types:

- **Limit (default):** Limits the minimum flow rate the motor can generate.
NOTE: This option is disabled when pump is in Flow mode.
- **Deviation:** Generates a deviation event when the pump flow rate drops below the specified limit.
- **Alarm:** Generates an alarm and shuts down the pump when the force drops below the specified limit.

High Flow Threshold (gallon/min, cc/min, oz/min, cycles/min)

This field is active when the profile is in Force mode, and it is disabled when the profile is in Flow mode.

This field can have three different event types. The default limit value is determined by the maximum flow rate that the pump can generate at 25 cycles per minute.

- **Limit (default):** Limits the maximum flow rate the pump can achieve.
- **Deviation:** Generates a deviation event when the pump exceeds the specified flow rate.
- **Alarm:** Generates an alarm and shuts down the pump when the specified limit is exceeded.

Low Pressure Threshold (psi, bar, MPa)

NOTE: This feature requires a pressure sensor and is only supported if using an E-Flo DCi Advanced motor.

This field is always active and is used to capture an event when the pump fluid pressure drops below the specified value. This can happen if the pump reaches its maximum flow and can't maintain pressure. This would capture a runaway event such as an empty tank/drum or a ruptured hose. The default value is 0%.

This field can have three different event types:

- **Limit:** Limits the minimum fluid pressure at the outlet of the pump.
NOTE: This option is disabled when pump is in Pressure mode.
- **Deviation:** Generates a deviation event when the fluid pressure drops below the minimum pressure specified.
- **Alarm:** Generates an alarm and shuts down the pump when the fluid pressure drops below the minimum pressure specified.

High Pressure Threshold (psi, bar, MPa)

NOTE: This feature requires a pressure sensor and is only supported if using an E-Flo DCi Advanced motor.

This field is active when the profile is in Force or Flow mode, and it is disabled when the profile is in Pressure Mode.

This field can have three different event types. The default value for maximum fluid pressure is 5000 psi. The Pressure High Limit depends on the lower size selected, and users must reference the pump manual to identify the maximum fluid pressure. See **Related Manuals**, page 2.

- **Limit:** Limits the maximum fluid pressure at the outlet of the pump.
- **Deviation:** Generates a deviation event when the fluid pressure exceeds the maximum pressure specified.
- **Alarm:** Generates an alarm and shuts down the pump when the fluid pressure limit is exceeded.

Maintenance

(SYSTEM > Configuration > Pump > [Maintenance])

The screenshot shows a web interface for pump maintenance configuration. At the top, there is a header 'Maintenance'. Below it, several metrics are displayed: 'Batch Total' (0.00 cycles), 'Maintenance 1 Total' (0 cycles), 'Maintenance 2 Total' (0 cycles), and 'Maintenance 3 Total' (0 cycles). A 'Grand Total' is shown as 21700 cycles. Below these are three rows for 'Maintenance Target 1', 'Maintenance Target 2', and 'Maintenance Target 3'. Each row has a dropdown menu set to 'Cycles', a numeric input field set to '0', and an 'Apply' button. At the bottom of the form, there are four blue buttons: 'Reset Maintenance 1', 'Reset Maintenance 2', 'Reset Maintenance 3', and 'Reset Batch'.

FIG. 36: Pump Maintenance Form

Batch Total

This indicates the current batch total in CCs

Maintenance Total (1-3)

The maintenance totalizer tracks the total cycles that the pump has run since the last maintenance clear event. An event is triggered once the totalizer counts up to the Maintenance Target.

NOTE: The maintenance totalizer does not start counting up until the Maintenance Target is set for that field.

Grand Total

The grand totalizer tracks the total cycles that the pump has run in its lifetime.

Maintenance Target (1-3)

Maintenance Target can be configured for Cycles or Days. When Cycles is selected, the user enters a specific amount of cycles that will count up from 0 to the target. When maintenance total equals the maintenance target the pump will trigger an event to notify the user. When Days is selected, the user enters a specific amount of days until the next service time is required. When the current day is equal to X amount of days after the last maintenance event was cleared a new event will be triggered to notify the user.

For example, oil should be changed after the first 200,000 to 300,000 cycles, and then after every 10 million cycles.

Digital Input

(SYSTEM > Configuration > Pump > [Digital Input])

NOTE: If using an E-Flo DCi Advanced motor, the Digital Inputs can be enabled and configured through either the *System Configuration* page, or through the *Pump* page. Configuring the digital inputs on either page will result in the same functionality. However, once this feature is enabled, it can only be replicated or configured on the other device. There will be an indicator explaining where the feature has already been enabled.

NOTE: The number of inputs available vary depending on whether an E-Flo DCi Advanced motor is used. See **Digital Input**, page 33, for information on configuring digital inputs without using an advanced motor.

Pump

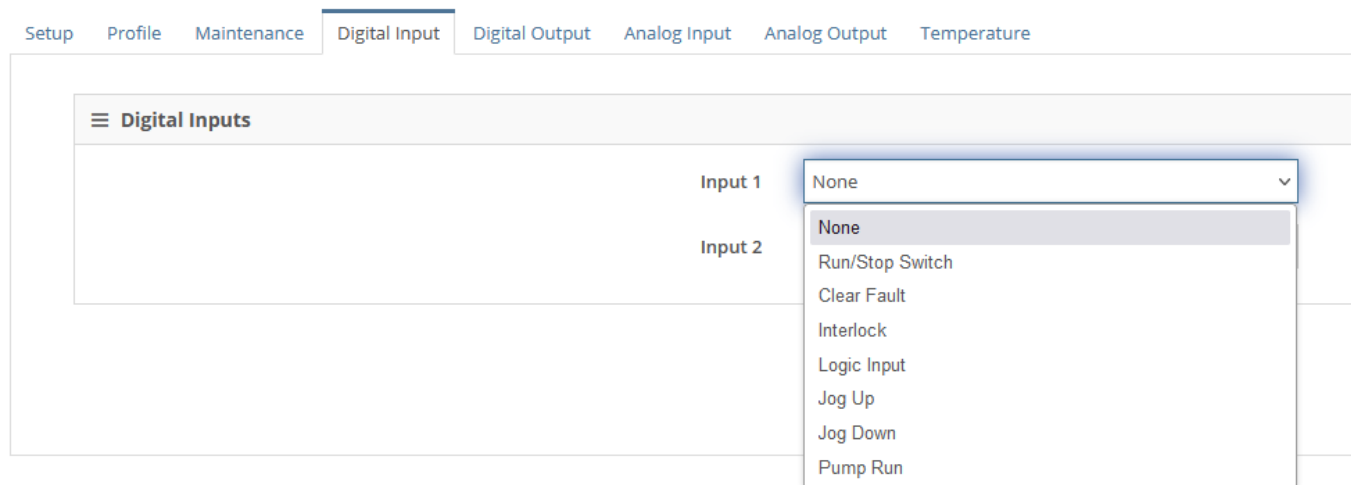

FIG. 37: Digital Input from Pump

Run/Stop Switch

Run/Stop switches pause pump operation at the station while the user performs a local operation around the station.

Input Value	Operation Mode	Description
0	Run (0 VDC)	The pump resumes operation when the switch is put into the Run position.
1	Stop (24 VDC)	The pump pauses operation when the switch is put into the Stop position.

Clear Event

Clears all active events on the pump, allowing the local operator to resume pump operation.

Input Value	Operation Mode	Description
0	N/A (0 VDC)	Does nothing.
1	Clear (24 VDC)	Clear all active events.

Interlock

Stops the pump when the interlock is active. The pump remains stopped even after the interlock event is deactivated. The pump must be reenabled (via Pump Run, the fieldbus, or the web interface) to resume operation.

Input Value	Operation Mode	Description
0	N/A (0 VDC)	The interlock event is cleared.
1	Stop (24 VDC)	Pump operation is stopped and cannot resume until the interlock is cleared.

Logic Input

Programmable Logic Control (PLC) reads the status of the DCi Link input to take specific action. The input is used as a remote bit to the Fieldbus controller; there is no direct operation for the DCi pump.

Input Value	Operation Mode	Description
0	Not Active (0 VDC)	Input is not active.
1	Active (24 VDC)	Input is active.

Jog Up

The motor exits Run mode and slowly jogs the motor shaft until it is fully retracted and then automatically goes to Off mode when the topmost position is detected. If the switch is returned to the Stop position before the motor shaft reaches the topmost position, the motor stops at its current position.

Input Value	Operation Mode	Description
0	N/A (0 VDC)	---
1	Jog Up (24 VDC)	The pump shaft moves to the uppermost position.

Jog Down

The motor exits Run mode and slowly jogs the motor shaft until it is fully extended and then automatically goes to Off mode when the bottommost position is detected. If the switch is returned to the Stop position before the motor shaft reaches the bottommost position, the motor stops at its current position.

Input Value	Operation Mode	Description
0	N/A (0 VDC)	---
1	Jog Down (24 VDC)	The pump shaft moves to the lowermost position.

Pump Run

When enabled, the pump run feature resumes operation of the pump. If the pump was running but was stopped by an alarm or interlock, the pump run feature will resume pump operation.

Input Value	Operation Mode	Description
0	N/A (0 VDC)	Does nothing
1	Start Pump (24 VDC)	The pump will resume operation if no event prevents the pump from running

Digital Output

(SYSTEM > Configuration > Pump > [Digital Output])

NOTE: If using an E-Flo DCi Advanced motor, the Digital Outputs can be enabled and configured through either the *System Configuration* page, or through the *Pump* page. Configuring the digital outputs on either page will result in the same functionality. However, once this feature is enabled, it can only be replicated or configured on the other device. There will be an indicator explaining where the feature has already been enabled.

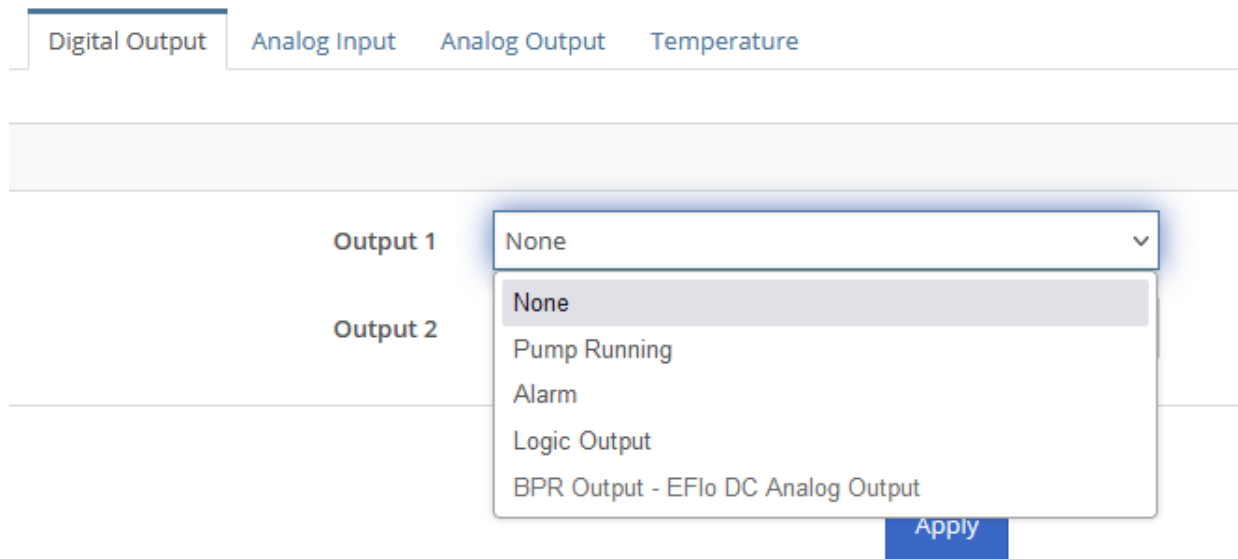

FIG. 38: Digital Output from Pump

Pump Running

Output is active while the motor is in Run mode. Output remains active even when the motor is stalled. Typical use is to connect the output to a light to indicate operation.

Output Value	Operation Mode	Description
0	Pump Not Active (0 VDC)	The pump is currently off.
1	Pump Active (24 VDC)	The pump is active and applying force.

Alarm

Output is active while the motor has an active alarm. Typical use is to connect the output to a light to indicate an alarm is active.

Output Value	Operation Mode	Description
0	Inactive Alarm (0 VDC)	No alarm is present.
1	Active Alarm (24 VDC)	An alarm has occurred and has not been cleared.

Logic Output

Logic output is driven by a Programmable Logic Controller (PLC) over a fieldbus to activate or deactivate output to drive local output near the manufacturing line. Logical Output is a sourcing output, see FIG. 12 to FIG. 15 (based on preferred wiring) for wiring and specifications.

Output Value	Operation Mode	Description
0	Not Active (0 VDC)	Does nothing.
1	Active (24 VDC)	The system applies 24 VDC to digital output.

Analog Input

(SYSTEM > Configuration > Pump > [Analog Input])

NOTE: If using an E-Flo DCi Advanced motor, the Analog Inputs can be enabled and configured through either the *System Configuration* page, or through the *Pump* page. Configuring the analog inputs on either page will result in the same functionality. However, once this feature is enabled, it can only be replicated or configured on the other device. There will be an indicator explaining where the feature has already been enabled.

NOTE: The Closed Loop Pressure Enable feature is only supported if using an E-Flo DCi Advanced motor.

NOTE: Be sure to select a pressure transducer that is no more than three times the maximum working pressure of the pump.

Pump

The screenshot shows the 'Pump' configuration page with the 'Analog Input' tab selected. It displays two channels of 4-20 mA input configuration. Each channel has an 'Enable' checkbox (checked), a 'Function' dropdown menu, '0% Value' and '100% Value' input fields, and a 'Close Loop Pressure Enable' checkbox (checked). The units for the values are 'Psi'. An 'Apply' button is located at the bottom right.

Channel	Enable	Function	0% Value	100% Value	Unit	Close Loop Pressure Enable
4-20mA - 1	<input checked="" type="checkbox"/>	Pump Outlet Pressure	0.00	5000.00	Psi	<input checked="" type="checkbox"/>
4-20mA - 2	<input checked="" type="checkbox"/>	BPR Pressure	0.00	5000.00	Psi	<input type="checkbox"/>

Fig. 39: Analog Input from Pump

4 to 20 mA Input

The 4-20 mA input is used to monitor system pressure. The user is required to enter the 0% and 100% process values for the sensor. This allows the system to convert from analog values to process values, assuming a linear line between these two points.

0% Value

To convert the 4-20 mA input to a process value, the user is required to enter a 0% value for the sensor. The system converts 4 mA to this value. This value specifies the zero (0) value.

100% Value

To convert the 4-20 mA input to a process value, the user is required to enter a 100% value for the sensor. The system converts 20 mA to this value. This value specifies the maximum value.

0 to 10 V Input

NOTE: This feature is not supported if using an E-Flo DCi Advanced motor.

The 0-10 V input is used to convert a potentiometer knob to a target flow rate or force command. The user is required to select the purpose of the 0-10 V knob: Flow or Force. The system converts 0-10 V to 0-100% of the target.

Analog Output

(SYSTEM > Configuration > Pump > [Analog Output])

NOTE: If using an E-Flo DCi Advanced motor, the Analog Outputs can be enabled and configured through either the *System Configuration* page, or through the *Pump* page. Configuring the analog outputs on either page will result in the same functionality. However, once this feature is enabled, it can only be replicated or configured on the other device. There will be an indicator explaining where the feature has already been enabled.

Pump

The screenshot shows the 'Pump' configuration page with the 'Analog Output' tab selected. The '4-20mA' section is expanded, showing an 'Enable' checkbox that is checked and a 'Function' dropdown menu set to 'Back Pressure Regulator'. An 'Apply' button is located at the bottom right of the configuration area.

FIG. 40: Analog Output from Pump

4 to 20 mA

The 4-20 mA output is used to control a back pressure regulator and is linked to the active profile back pressure regulator value. The profile supports values 0-100% for a back pressure regulator. 0% is equal to a 4 mA output value, while 100% is equal to a 20 mA output value.

Temperature

(SYSTEM > Configuration > Pump > [Temperature])

NOTE: This feature is only configurable if using an E-Flo DCi Advanced motor.

Pump

Setup Profile Maintenance Digital Input Digital Output Analog Input Analog Output Temperature

≡ RTD

Enable

Type

Slope

Offset

Apply

FIG. 41: Temperature from Pump

The temperature input is used to measure fluid temperature at the motor. This input uses a Platinum 100 RTD and supports two different types:

- Type-385
- Type-392

Enable Fieldbus

(**CONNECTIVITY** > **Interfaces** > [**Fieldbus**])

1. On the web interface select **Connectivity** > **Interface** > **Fieldbus** to display the *Fieldbus* form.

FIG. 42: Fieldbus Protocol Field Locked

2. Click the toggle button in the title bar and then the one next to the **Fieldbus Protocol** field to unlock the *Fieldbus* form for editing.

FIG. 43: Fieldbus Protocol Field Unlocked

3. Click in the **Fieldbus Protocol** field and select one of the following protocols:
 - PROFINET (see **PROFINET**, page 51)
 - Modbus TCP (see **Modbus TCP**, page 52)
 - EtherNet/IP (see **EtherNet/IP**, page 52)

NOTE: The remaining fields on the *Fieldbus* form depend on which protocol is selected.

PROFINET

FIG. 44: PROFINET Fieldbus Protocols

If the toggle button next to the **Fieldbus** field is red, click it to unlock the remaining editable fields.

MAC Address

Displays the MAC address of the ethernet port (ETH2 A/B). See **Component Identification**, page 13.

IP Address

Displays the IP address of the DCi Link that was assigned by the PLC to the device.

Vendor ID

Specifies the Graco PROFINET vendor ID.

Vendor Name

Specifies Graco Inc. as the vendor name that is communicated on the PROFINET network.

Station Name

Every PROFINET device is identified with its station name. The station name of the devices allows easy identification of the device by users. Station names are defined in the standard IEC 61158-6010.

- The device name must not be longer than 240 characters. The following characters are permitted:
 - Lowercase letters “a” to “z”
 - Numbers “0” to “9”
 - Hyphen or period
- One name component in the device name (a character string between two periods) may not be longer than 63 characters.

Enable Fieldbus

- The device name may not begin or end with a hyphen.
- The device name may not begin with the character string “port-xyz” (x, y, z - 0 to 9).
- The device name must not have the form of an IP address; n.n.n.n (n = 0 to 255).

Modbus TCP

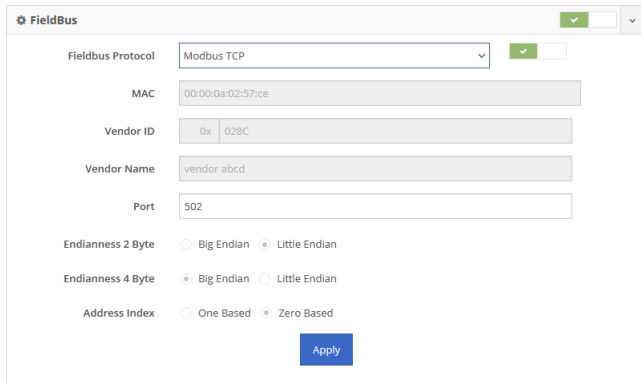

FIG. 45: Modbus TCP Fieldbus Protocols

If the toggle button next to the **Fieldbus** field is red, click it to unlock the remaining editable fields.

Vendor ID

Specifies the Graco Modbus TCP vendor ID.

Vendor Name

Specifies Graco Inc. as the vendor name that is communicated on the Modbus TCP network.

Port

Identifies the Modbus TCP port used by this gateway. The default port for Modbus/TCP is 502.

Endianness

MODBUS uses a “big-Endian” representation for addresses and data items. This means that when a numerical quantity larger than a single byte is transmitted, the most significant byte is sent first. This interface allows the user to configure differently if there is equipment on the network that does not follow this standard.

- **Endianness 2 Byte:** Two-byte endianness is used when the user is using 16 bits for a variable.

Example Big Endian

Value: 0x1234, the first byte sent is 0x12, then 0x34.

- **Endianness 4 Byte:** Four-byte endianness is used when the user is using 32 bits for a variable.

Example Big Endian

Value: 0x12345678, the first byte sent is 0x12, then 0x34, 0x56, and 0x78.

Address Index

Defines how the gateway handles generating offsets. It specifies whether the start offset is 0 or 1. For example, the first holding register in a map is 40001 for one-based or 40000 for zero-based.

EtherNet/IP

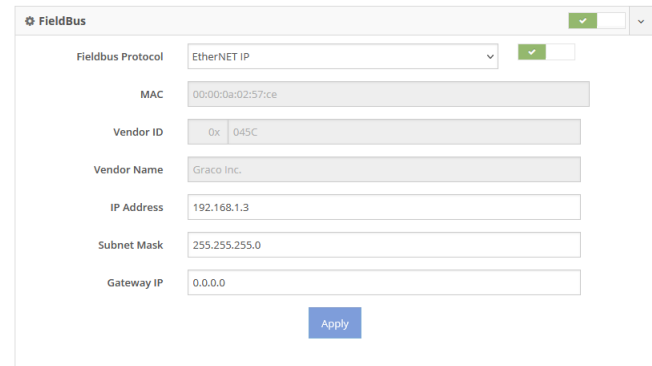

FIG. 46: EtherNet/IP Fieldbus Protocols

If the toggle button next to the **Fieldbus** field is red, click it to unlock the remaining editable fields. Click **Apply** after modifying the fields to save changes.

MAC Address

Displays the MAC address of the ethernet port (ETH2 A/B). See **Component Identification**, page 13.

Vendor ID

Specifies the Graco ODVA vendor ID.

Vendor Name

Specifies Graco Inc. as the vendor name that is communicated on the EtherNet/IP network.

IP Address, Subnet Mask, and Default Gateway

Assign the IP address for the fieldbus network to the DCi Link.

Integration

When the pump powers up, it will go through an initialization state where the pump configures itself and runs self-tests. If the unit has any failures, it can get stuck in this state and will display a red flashing LED to indicate the error. See **Pump Mode**, page 55.

After the initialization stage is complete, the pump will enter a state of Ready. This can be determined if Status-General-Pump Mode is equal to 2, and Status-General-Status Bits 0 and 1 are equal to 0 (see **Pump Mode**, page 55). In the Ready state, the pump is ready to receive the commanded to run.

When the pump is commanded to run by sending a 1 to the Pump Enable Command (see **Pump Enable**, page 71), the pump will enter a state of Inhibited. This can be determined if Status-General-Pump Mode is equal to 2, Status-General-Status Bits 0 is equal to 1, and bit 1 is equal to 0 (see **Pump Mode**, page 55). If the following conditions are met, the pump will automatically enter a Run state: Run/Stop is false, no active alarms, and Interlock is false. In the Inhibit state, the motor is not commutating.

In the Run state, the pump will begin commutation and run the active profile.

The active profile can be selected using the **Active Profile**, page 71. In the active profile, the system determines what control mode to run: Force, Pressure, or Flow Rate. See **Profile**, page 41, for more detail.

If an alarm or run/stop switch is active, the system will enter the Inhibit state and will recover when the alarm or run/stop switch is cleared.

If an interlock is active, the pump will enter the Ready state and will require a pump enable command to begin operation once the interlock is cleared. If the fieldbus has Command-Status-Pump Enable mapped and is continuously sending an enable command after the interlock is cleared, the pump will immediately begin operation. If user intervention is desired, the fieldbus must send the Command-Status-Pump Enable to 0 at the same time an interlock is active.

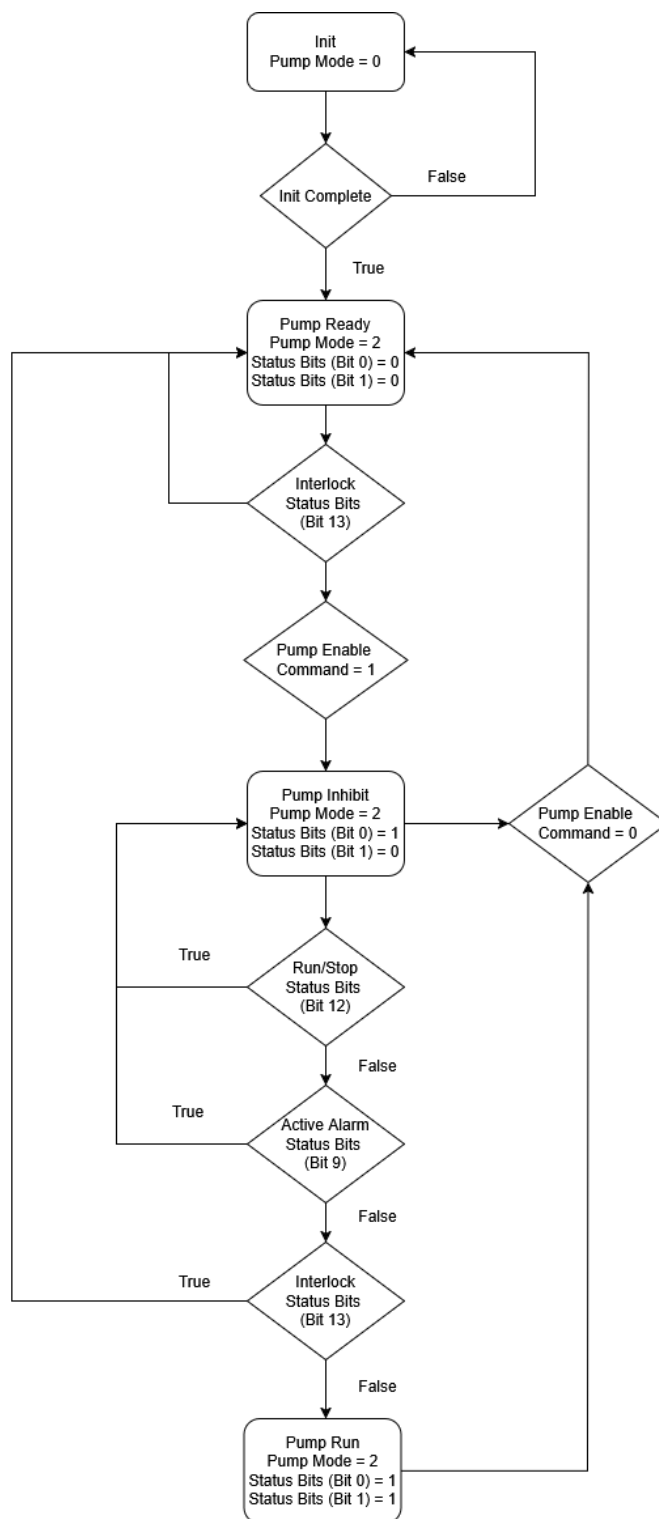

FIG. 47: Sequence of Operation

Mapping

Mapping is where the user specifies all of the variables that the DCi Link will use to communicate over the fieldbus network. Two different component types are supported:

- Station: Variables associated with the DCi Link
- Pump: Variables associated with the pump

Each component can have both input and output variable types. Outputs are defined as DCi -> PLC, and inputs are defined as PLC -> DCi.

E-Flo DCi Data

Status-General

Seconds Counter

This register increments by one every second, rolling over from 59 back to 0. This can be used to ensure communication is still active.

Status Bits

The register is a bitfield with each bit corresponding to a particular status flag.

Bit	Status	Description
0	Pump Enabled	Pump is enabled and allowed to start pumping.
1	Pump Active	Pump is controlling the motor output. This can be inhibited by an active alarm, interlock, or run/stop switch.
2	Pump Stalled	Pump is not moving.
3	At Force	Pump is operating at the target force.
4	At Speed	Pump is operating at the target speed.
5	At Pressure	Pump is operating at the target pressure.
6	Force Limit Active	Pump is operating at the force limit and might experience a reduction in flow rate
7	Pressure Limit Active	Pump is operating at maximum pressure and might experience a reduction in flow rate.
8	Flow Limit Active	Pump is operating at maximum flow rate and might experience a reduction in force/pressure.
9	Active Alarm	An alarm is active.
10	Active Deviation	A deviation event is active.
11	Active Advisory	An advisory event is active.
12	Run/Stop Switch	Current status of the physical stop switch. (0 = not stopped, 1 = stopped)
13	Interlock Status	The interlock input is active and the pump is off.
14	On/Off Production	The pump is running the production profile.

Bit	Status	Description
15	Local/Remote*	Indicates whether the system is controlled locally (0) or remotely (1).
16	Setup Changed	One or more setup values have been changed.
17	Profile 0 Changed	The settings for Profile 0 have been changed.
18	Profile 1 Changed	The settings for Profile 1 have been changed.
19	Profile 2 Changed	The settings for Profile 2 have been changed.
20	Profile 3 Changed	The settings for Profile 3 have been changed.
21	Profile 4 Changed	The settings for Profile 4 have been changed.
22	Maintenance Changed	One or more maintenance settings have been changed.
23	Digital Input 1	Digital Input 1 is status (0 = Not Active, 1 = Active)
24	Digital Input 2	Digital Input 2 is status (0 = Not Active, 1 = Active)
25	Digital Output 1	Digital Output 1 is status (0 = Not Active, 1 = Active)
26	Digital Output 2	Digital Output 2 is status (0 = Not Active, 1 = Active)

* Local control refers to the DCi Motor Knob (N) at the pump.

Pump Mode

This register contains a number indicating the current pump mode.

Number	Mode	Description
0	Init	Pump is powered on and initializing.
1	Idle	Pump is idle and ready to run.
2	Run	Pump is running.
3	Jog	Pump is jogging.

Active Profile

This register indicates the active profile number. 0 is the dynamic profile, and 1-4 are the fixed profiles.

Number	Profile	Description
0	Dynamic Profile	Dynamic profile information is not stored through power cycles and must be configured over fieldbus for the pump to operate.
1-4	Fixed Profiles	Fixed profiles are stored through a power cycle and are intended to allow the user to control their process. Fixed profiles don't need to be configured each time and the pump can resume operation upon startup without.

Pump Speed

This indicates the current pump speed in cycles per minute. The value is reported with an implied decimal to the hundredth. Example: 10 CPM will report at 1000.

Flow Rate

This indicates the current flow rate in the configured flow units for the system. The value is reported with an implied decimal to the hundredth. Example: 10.65 GPM will report at 1065.

Force

This indicates the current force in percent of maximum (0 - 100%). The value is reported with an implied decimal to the hundredth. Example: 50.56% will report at 5056.

Pump Outlet Pressure

This indicates the current pump outlet pressure in the configured pressure units for the system. The value is reported with an implied decimal to the hundredth. Example: 51.51 bar will report at 5151.

Back Pressure Regulator Pressure

This indicates the current pressure at the back pressure regulator in the configured pressure units for the system. The value is reported with an implied decimal to the hundredth. Example: 51.51 bar will report at 5151.

Back Pressure Regulator Output

This indicates the current BPR output in percent of maximum (0 - 100%). Value is reported in whole numbers. Example: 30% is equal to 30.

Active Power

This indicates the active power in watts that the motor is operating at. The value is reported with an implied decimal to the hundredth. Example: 1052.34W will report at 105234.

Energy Consumption

This indicates the energy consumption in kWh. The value is reported with an implied decimal to the hundredth. Example: 27.32kWh will report at 2732.

Temperature (Advanced Only)

This indicates the current temperature measured at the RTD input on port 5 of advanced models only. The value is reported with an implied decimal to the hundredth. Example: 79.56F will report at 7956.

Motor Events 1 - Active

This register is a bitfield where each bit corresponds to a particular motor event (1=event is active).

Bit	Event	Description
0	Software Overcurrent Pause	Motor current exceeded the software threshold for a small period of time, but system resumed operation.
1	Software Overcurrent	Motor current exceeded the software threshold for an extended period of time and the system shutdown.
2	Hardware Failure Current Sense	System detected a failure with the current sensor.
3	Hardware Overcurrent Pause	Motor current exceed the hardware current limit and had to shutdown immediately to protect the hardware and will try to resume operation if failure mode is no longer present.
4	Hardware Overcurrent	Motor current exceed the hardware current limit and had to shutdown immediately to protect the hardware.

Bit	Event	Description
5	Bus Overvoltage	DC bus voltage exceeded normal operating level.
6	Bus Undervoltage	DC bus voltage dropped below normal operating level.
7	AC Overvoltage	AC input voltage exceeded normal operating level.
8	AC Undervoltage	AC input voltage dropped below normal operating level.
9	AC Power Loss	Detected a loss of AC power.
10	AC Missing Phase	Detected a missing phase in the AC input voltage.
11	AC Phase Current Imbalance	Detected an imbalance in current levels across AC input phases.
12	AC Phase Voltage Imbalance	Detected an imbalance in voltage levels across AC input phases.
13	Motor Temperature High Alarm	Motor temperature exceeded the alarm level.
14	Motor Temperature High Deviation	Motor temperature exceeded the deviation/warning level.
15	Motor Temperature Sensor Disconnected	Motor temperature sensor is not properly connected.
16	Processor Temperature High Alarm	Processor temperature exceeded the alarm level.
17	Processor Temperature High Deviation	Processor temperature exceeded the deviation/warning level.
18	Processor Temperature Sensor Failure	Processor temperature sensor is not properly connected.
19	IGBT Temperature High Alarm	IGBT temperature exceeded the alarm level.
20	IGBT Temperature High Deviation	IGBT temperature exceeded the deviation/warning level.

Bit	Event	Description
21	IGBT Temperature Sensor Failure	IGBT temperature sensor is not properly connected.
22	Board Temperature High Alarm	Circuit board temperature exceeded the alarm level.
23	Board Temperature High Deviation	Circuit board temperature exceeded the deviation/warning level.
24	Board Temperature Sensor Failure	Circuit board temperature sensor is not properly connected.

Profile Events - Active

This register is a bitfield where each bit corresponds to a particular profile event (1=event is active).

Bit	Event	Description
0	Force Minimum Deviation	Force dropped below the minimum deviation value.
1	Force Minimum Alarm	Force dropped below the minimum alarm limit.
2	Force Maximum Deviation	Force exceeded the maximum deviation value.
3	Force Maximum Alarm	Force exceeded the maximum alarm limit.
4	Pressure Minimum Deviation	Pressure dropped below the minimum deviation value.
5	Pressure Minimum Alarm	Pressure dropped below the minimum alarm limit.
6	Pressure Maximum Deviation	Pressure exceeded the maximum deviation value.
7	Pressure Maximum Alarm	Pressure exceeded the maximum alarm limit.
8	Flow Rate Minimum Deviation	Flow rate dropped below the minimum deviation value.

Bit	Event	Description
9	Flow Rate Minimum Alarm	Flow rate dropped below the minimum alarm limit.
10	Flow Rate Maximum Deviation	Flow rate exceeded the maximum deviation value.
11	Flow Rate Maximum Alarm	Flow rate exceeded the maximum alarm limit.

Status-General Data Map (Read Only)

Register Name	Data Type	Range	Units	User Rights	Description
Seconds Counter	UINT32	0-59	Seconds	Read	Increments every second and rolls over. Can be used to ensure communication is still active.
Status Bits	UINT32	---	---	Read	0 = Pump Enabled 1 = Pump Active 2 = Pump Stalled 3 = At Force 4 = At Speed 5 = At Pressure 6 = Force Limit Active 7 = Pressure Limit Active 8 = Flow Limit Active 9 = Active Alarm 10 = Active Deviation 11 = Active Advisory 12 = Run/Stop Status 13 = Interlock Status 14 = On/Off Production 15 = Local/Remote 16 = Setup Changed 17 = Profile 0 Changed 18 = Profile 1 Changed 19 = Profile 2 Changed 20 = Profile 3 Changed 21 = Profile 4 Changed 22 = Maintenance Changed 23 = Digital Input 1 24 = Digital Input 2 25 = Digital Output 1 26 = Digital Output 2
Pump Mode	UINT32	0-6	---	Read	0 = Init 1 = Idle 2 = Run 3 = Jog
Active Profile	UINT32	0-4	---	Read	0 = Dynamic profile 1-4 = Fixed profiles
Active Profile Mode	UINT32	0-4	---	Read	0 = Force 1 = Pressure (Advanced Only) 2 = Flow
Actual Pump Speed	UINT32	0-2	Cycle Per Minute	Read	Current pump speed in cycles per minute Example 1056 = 10.56 CPM
Actual Flow Rate	UINT32	0-999999	User-selected flow rate units (GPM, LPM, cc/min, oz/min, CPM)	Read	Current flow rate in user-selected units. Example: 1523 = 15.23 GPM
Actual Force	UINT32	0-10000	%	Read	Current force 0-100% of Pumps capable force (3000 = 30.00%)

Register Name	Data Type	Range	Units	User Rights	Description
Pump Outlet Pressure	UINT32	0-999999	User-selected pressure units (psi, bar, MPa)	Read	Current pressure at the outlet of the pump in user-selected units. Example: 32056 = 320.56 psi (Advanced Only)
BPR Pressure	UINT32	0-999999	User-selected pressure units (psi, bar, MPa)	Read	Current pressure at the back pressure regulator user-selected units. Example: 32056 = 320.56 psi (Advanced Only)
BPR Output	UINT32	0-100	%	Read	Current BPR output in % Example: 30 = 30% (Advanced Only)
Active Power	UINT32	0-999999	Watts	Read	Active power in Watts. Example: 109658 = 1096.58W
Energy Consumption	UINT32	0-9999	kWh	Read	Energy consumption in kWh. Example: 2857 = 28.57kWh

Register Name	Data Type	Range	Units	User Rights	Description
Motor Events 1 - Active	UINT32	---	---	Read	Bit 0 = Software Overcurrent Pause Bit 1 = Software Overcurrent Bit 2 = Hardware Failure Current Sense Bit 3 = Hardware Overcurrent Pause Bit 4 = Hardware Overcurrent Bit 5 = Bus Overvoltage Bit 6 = Bus Undervoltage Bit 7 = AC Overvoltage Bit 8 = AC Undervoltage Bit 9 = AC Power Loss Bit 10 = AC Missing Phase Bit 11 = AC Phase Current Imbalance Bit 12 = AC Phase Voltage Imbalance Bit 13 = Motor Temperature High Alarm Bit 14 = Motor Temperature High Deviation Bit 15 = Motor Temperature Sensor Disconnected Bit 16 = Processor Temperature High Alarm Bit 17 = Processor Temperature High Deviation Bit 18 = Processor Temperature Sensor Failure Bit 19 = IGBT Temperature High Alarm Bit 20 = IGBT Temperature High Deviation Bit 21 = IGBT Temperature Sensor Failure Bit 22 = Board Temperature High Alarm Bit 23 = Board Temperature High Deviation Bit 24 = Board Temperature Sensor Failure
Profile Events - Active	UINT32	---	---	Read	Bit 0 = Force Minimum Deviation Bit 1 = Force Minimum Alarm Bit 2 = Force Maximum Deviation Bit 3 = Force Maximum Alarm Bit 4 = Pressure Minimum Deviation Bit 5 = Pressure Minimum Alarm Bit 6 = Pressure Maximum Deviation Bit 7 = Pressure Maximum Alarm Bit 8 = Flow Rate Minimum Deviation Bit 9 = Flow Rate Minimum Alarm Bit 10 = Flow Rate Maximum Deviation Bit 11 = Flow Rate Maximum Alarm

Setup-General

Pump Configuration

This register is a bitfield where each bit corresponds to a particular configuration setting.

Bit	Event	Description
0	On/Off Production Enable	Production profile use is enabled. (1=enabled)
1	Closed Loop Pressure	Closed loop pressure control is enabled. (1=enabled) (Advanced Only)
2	Remote Start	Allows starting the pump remotely. (1=enabled)
3	Auto Restart	Pump will resume operation from last active profile after power up. (1 = enabled). To operate profile user needs to use fixed profiles 1-4. Profile 0 resets all profile values back to 0 after a power cycle.
4	Communication Alarm	If communication is lost between fieldbus network and DCi Link pump will stop when enabled. (1=enabled)

Production Profile

This indicates the current production profile number. Production profile is only used when user is using the production On/Off feature. When Production is ON then the system will use the profile listed for Production Profile.

Off Production Profile

This indicates the current off production profile number. Off Production profile is only used when user is using the production On/Off feature. When Production is OFF then the system will use the profile listed for Off Production Profile.

Lower Size

This indicates the current pump lower size in cubic centimeters (cc). If the value is set to 0 the system can't report a flow rate.

Digital Input Function 1-2 (Advanced Only)

The digital input function allows each input to be configured to serve a particular purpose.

For the Digital Inputs, the advanced motor has the following features.

Number	Function	Description
0	None	Not Configured
1	Run/Stop	When input is active (1) the pump will remain in run mode. If the input goes to inactive (0) the pump will pause operation. Purpose is for a user at the station to pause the pump locally.
2	Clear Fault	When input is active (1). The system will try to clear any active fault.
3	Interlock	When input is active (1) the motor will stop operation and enter pump off mode. Interlock must be removed before pump can resume operation.
4	Logic Input	Report status of logic input back to fieldbus network.
5	Jog Up	When input is active the pump will enter Jog Up mode and jog the pump to upper most position. The system will automatically go back to idle once it reaches the top.
6	Jog Down	When input is active the pump will enter Jog Down mode and jog the pump to lower most position. The system will automatically go back to idle once it reaches the bottom.
7	Pump Run	When input is active (1) the pump will enter Pump enabled mode. If profile contains proper values system will resume operation.

Digital Output Function 1-2 (Advanced Only)

The digital output function allows each output to be configured to serve a particular purpose.

For the Digital Outputs, the advanced motor has the following features.

Number	Function	Description
0	None	Not Configured
1	Pump Running	If the pump is running, then the output will be active. Status bit Pump Active is equal to 1 then 24VDC will be applied.
2	Alarm	If there is an active alarm, then the output will be active. Status bit Active Alarm is equal to 1 then 24VDC will be applied.
3	Logic Output	Digital output can be enabled over the fieldbus to control a user desired function.
4	BPR Output	For simple back pressure regulator systems that don't have pneumatic control and used fixed orifice or fixed restriction to control. If this feature is enabled that Analog Output function of BPR is disabled.

Analog Input 1 Function (Advanced Only)

Analog input function allows the user to specify the purpose of the analog input. This was designed for pressure sensor input at the outlet of the pump but can be used as a generic 4-20mA analog input.

Number	Function	Description
0	None	Not Configured
1	Pump Outlet Pressure	Reads the analog input as the pump outlet pressure in user specified units.

Analog Input 1 Process Value 0 (Advanced Only)

The process value 0 specifies the value of the sensor at 4mA. This value is usually 0.

Analog Input 1 Process Value 100 (Advanced Only)

The process value 100 specifies the value of the sensor at 20mA. This value is the rating of the sensor used.

Analog Input 2 Function (Advanced Only)

Analog input function allows the user to specify the purpose of the analog input. This was designed for pressure sensor input at the outlet of the pump but can be used as a generic 4-20mA analog input.

Number	Function	Description
0	None	Not Configured
1	Back Pressure Regulator Pressure	Reads the analog input as the pressure at the back pressure regulator in user specified units.

Analog Input 2 Process Value 0 (Advanced Only)

The process value 0 specifies the value of the sensor at 4mA. This value is usually 0.

Analog Input 2 Process Value 100 (Advanced Only)

The process value 100 specifies the value of the sensor at 20mA. This value is the rating of the sensor used.

Analog Output Function (Advanced Only)

Analog output function allows the user to configure the purpose of the analog output 4-20mA to be used to control a pneumatic BPR controller using a current to pressure transducer.

Number	Function	Description
0	None	Not Configured
1	Back Pressure Regulator	Configures analog output to be linked to the active profile back pressure regulator setting.

Setup-General Data Map (Read Only)

General Setup	Data Type	Range	Units	User Rights	Description
Pump Configuration	UINT32	---	---	Read	Bit 0: On/Off Production Enable 0 = Disable 1 = Enable Bit 1: Closed Loop Pressure 0 = Disabled 1 = Enabled Bit 2: Remote Start 0 = Disabled 1 = Enabled Bit 3: Auto Restart 0 = Disabled 1 = Enabled Bit 4: Comm Alarm 0 = Disabled 1 = Enabled
Production Profile	UINT32	1-4	---	Read	Current production profile number.
Off Production Profile	UINT32	1-4	---	Read	Current off production profile number.
Lower Size	UINT32	0-65535	cc	Read	Current lower size (cc).
Digital Input Function 1	UINT32	0-7	---	Read	0 = None 1 = Run/Stop 2 = Clear Fault 3 = Interlock 4 = Logic Input 5 = Jog Up 6 = Jog Down 7 = Pump Run
Digital Input Function 2	UINT32	0-7	---	Read	0 = None 1 = Run/Stop 2 = Clear Fault 3 = Interlock 4 = Logic Input 5 = Jog Up 6 = Jog Down 7 = Pump Run
Digital Output Function 1	UINT32	0-4	---	Read	0 = None 1 = Pump Running 2 = Alarm 3 = Logic Output 4 = BPR Output
Digital Output Function 2	UINT32	0-4	---	Read	0 = None 1 = Pump Running 2 = Alarm 3 = Logic Output 4 = BPR Output

General Setup	Data Type	Range	Units	User Rights	Description
Analog Input 1 Function	UINT32	0-2	---	Read	0 = None 1 = Pump Pressure 2 = BPR Pressure
Analog Input 1 Process Value 0	UINT32	0-999999	psi, bar, MPa	Read	Process value at 4mA
Analog Input 1 Process Value 100	UINT32	0-999999	psi, bar, MPa	Read	Process value at 20mA
Analog Input 2 Function	UINT32	---	---	Read	0 = None 1 = Pump Pressure 2 = BPR Pressure
Analog Input 2 Process Value 0	UINT32	0-999999	psi, bar, MPa	Read	Process value at 4mA
Analog Input 2 Process Value 100	UINT32	0-999999	psi, bar, MPa	Read	Process value at 20mA
Analog Output Function	UINT32	---	---	Read	0 = None 1 = Back Pressure Regulator

Profiles

E-Flo DCi Link allows for up to five profiles (0-4) in the system. Each profile has a similar set of outputs with each output specific to one of the five profiles.

NOTE: When changing between profiles, the system applies a 5 second blanking time before triggering events.

Mode

This indicates the current control mode for the profile.

Number	Mode	Description
0	Force	Maintains the target pump force, regardless of cycle rate (up to the maximum cycle rate).
1	Pressure	Maintains the target pressure at the outlet of the pump (Advanced Only).
2	Flow	Maintains the target flow rate, regardless of pressure (up to the pump's maximum working pressure).

Force Target

This indicates the current force set point for the profile.

Force Minimum Event Value

This indicates the force minimum event value for the profile.

Force Minimum Event Type

This indicates the type for the force minimum event. The event type determines how the system responds if the pump begins to operate below the event value.

Number	Event Type	Description
0	Limit	No action - the system continues to run.
1	Deviation	If force drops below the event value for 1 second, the system will trigger an event notifying the user.
2	Alarm	If force drops below the event value for 1 second, the system will shut down.

Force Maximum Event Value

This indicates the force maximum event value for the profile.

Force Maximum Event Type

This indicates the type for the force maximum event. The event type determines how the system responds if the pump begins to operate above the event value.

Number	Event Type	Description
0	Limit	The system continues to run, reducing the flow rate to prevent exceeding the force limit.
1	Deviation	If force goes above the event value for 1 second, the system will trigger an event notifying the user.
2	Alarm	If force goes above the event value for 1 second, the system will shut down and notify the user.

Pressure Target

This indicates the current pressure set point for the profile. The pump will run in closed loop pressure control to the pressure sensed at the outlet pump.

Pressure Minimum Event Value

This indicates the pressure minimum event value for the profile.

Pressure Minimum Event Type

This indicates the type for the pressure minimum event. The event type determines how the system responds if the pump begins to operate below the event value.

Number	Event Type	Description
0	Limit	No action - the system continues to run.
1	Deviation	If pressure drops below the event value for 1 second, the system will trigger an event notifying the user.
2	Alarm	If pressure drops below the event value for 1 second, the system will shut down.

Pressure Maximum Event Value

This indicates the pressure maximum event value for the profile.

Pressure Maximum Event Type

This indicates the type for the pressure maximum event. The event type determines how the system responds if the pump begins to operate above the event value.

Number	Event Type	Description
0	Limit	The system continues to run, reducing the flow rate to prevent exceeding the pressure limit.
1	Deviation	If pressure goes above the event value for 1 second, the system will trigger an event notifying the user.
2	Alarm	If pressure goes above the event value for 1 second, the system will shut down and notify the user.

Flow Target

This indicates the current flow rate set point for the profile.

Flow Minimum Event Value

This indicates the flow rate minimum event value for the profile.

Flow Minimum Event Type

This indicates the type for the flow rate minimum event. The event type determines how the system responds if the pump begins to operate below the event value.

Number	Event Type	Description
0	Limit	No action - the system continues to run.
1	Deviation	If flow rate drops below the event value for 1 second, the system will trigger an event notifying the user.
2	Alarm	If flow rate drops below the event value for 1 second, the system will shut down.

Flow Maximum Event Value

This indicates the flow rate maximum event value for the profile.

Flow Maximum Event Type

This indicates the type for the flow rate maximum event. The event type determines how the system responds if the pump begins to operate above the event value.

Number	Event Type	Description
0	Limit	The system continues to run, reducing the force or pressure to prevent exceeding the flow rate limit.
1	Deviation	If flow rate goes above the event value for 1 second, the system will trigger an event notifying the user.
2	Alarm	If flow rate goes above the event value for 1 second, the system will shut down and notify the user.

BPR Closed Percent Target

This indicates the current back pressure regulator output as a percentage (0% = fully open, 100% = fully closed). This value will control the analog output port (Advanced Only).

Profile Data Map (Read Only)

Register List	Data Type	Range	Units	User Rights	Description
Control Mode	UINT32	0-2	---	Read	0 = Force 1 = Pressure 2 = Flow
Force Target	UINT32	0-10000	%	Read	Current force set point in %.
Force Minimum Event Value	UINT32	0-10000	%	Read	Current force minimum event value in %. Must be less than target.
Force Minimum Event Type	UINT32	0-2	---	Read	Actual force drops below the target for 1 second 0: Limit 1: Deviation 2: Alarm
Force Maximum Event Value	UINT32	0-10000	%	Read	Current force maximum event value in %. Must be greater than target.
Force Maximum Event Type	UINT32	0-2	---	Read	Actual force goes above the target for 1 second 0: Limit 1: Deviation 2: Alarm
Pressure Target	UINT32	0-999999	psi, bar, MPa	Read	Pressure set point in user units: psi, bar, MPa
Pressure Minimum Event Value	UINT32	0-999999	psi, bar, MPa	Read	Pressure minimum event value in user pressure units: psi, bar, MPa. Must be less than target.
Pressure Minimum Event Type	UINT32	0-2	---	Read	Actual Pressure drops below target for 1 second 0 = Limit 1 = Deviation 2 = Alarm
Pressure Maximum Event Value	UINT32	0-999999	psi, bar, MPa	Read	Pressure maximum event value in user pressure units: psi, bar, MPa. Must be greater than target.
Pressure Maximum Event Type	UINT32	0-2	---	Read	Actual Pressure goes above target for 1 second 0 = Limit 1 = Deviation 2 = Alarm
Flow Target	UINT32	0-65535	User-selected flow rate units (GPM, LPM, cc/min, oz/min, CPM)	Read	Current flow rate set point in user-selected flow rate units. Maximum value is determined by motor and pump size.

Register List	Data Type	Range	Units	User Rights	Description
Flow Minimum Event Value	UINT32	0-65535	User-selected flow rate units (GPM, LPM, cc/min, oz/min, CPM)	Read	Current flow rate minimum event value in user-selected flow rate units. Must be less than target.
Flow Minimum Event Type	UINT32	0-2	-	Read	Actual flow rate goes below target for 1 second 0: Limit 1: Deviation 2: Alarm
Flow Maximum Event Value	UINT32	0-65535	User-selected flow rate units (GPM, LPM, cc/min, oz/min, CPM)	Read	Current flow rate minimum event value in user-selected flow rate units. Must be greater than target.
Flow Maximum Event Type	UINT32	0-2	-	Read	Actual flow rate goes above target for 1 second 0: Limit 1: Deviation 2: Alarm
BPR Closed Percent Target	UINT32	0-100	%	Read	Current back pressure regulator output in % (0% = Open, 100% = Closed).

Maintenance-General

Batch Total

This indicates the current batch total in cubic centimeters. Batch total can track the material pumped for a specific batch and the value can be cleared to track the total for the next dispense/batch.

Maintenance 1-3 Cycles Target

The pump cycles allow the user to specify the number of pump cycles before next service. A cycle is one full stroke up and down. The maintenance target is defaulted to 0 initial. Once the user sets a target then the total will start counting.

Maintenance 1-3 Days Target

Days allows the user to specify days before next service vs pump cycles. When user has days selected instead of cycles the maintenance total will count in days.

Maintenance 1-3 Total

Maintenance total is the current pump cycle or day total since last time it was reset. When total exceeds the target, an event will be generated to notify the user.

Grand Total

Grand total tracks the total cycles for the motor over its total hours of operation. This register can't be reset.

Maintenance-General Data Map (Read Only)

Register Name	Data Type	Range	Units	User Rights	Description
Batch Total	UINT32	0-4294967295	Cubic Centimeters (cc)	Read	Current batch total in cubic centimeters (cc).
Maintenance 1 Cycles Target	UINT32	0-4294967295	Cycles	Read	Maintenance target in cycles.
Maintenance 1 Days Target	UINT32	0-4294967295	Days	Read	Maintenance target in days.
Maintenance 1 Total	UINT32	0-4294967295	Cycles or Days	Read	Maintenance counter incrementing in cycles or days based on user selection.
Maintenance 2 Cycles Target	UINT32	0-4294967295	Cycles	Read	Maintenance target in cycles.
Maintenance 2 Days Target	UINT32	0-4294967295	Days	Read	Maintenance target in days.
Maintenance 2 Total	UINT32	0-4294967295	Cycles or Days	Read	Maintenance counter incrementing in cycles or days based on user selection.
Maintenance 3 Cycles Target	UINT32	0-4294967295	Cycles	Read	Maintenance target in cycles.
Maintenance 3 Days Target	UINT32	0-4294967295	Days	Read	Maintenance target in days.
Maintenance 3 Total	UINT32	0-4294967295	Cycles or Days	Read	Maintenance counter incrementing in cycles or days based on user selection.
Grand Total	UINT32	0-4294967295	Cycles	Read	Tracks the total cycles for the motor.

Command-Status

Pump Enable

This enables (1) or disables (0) the pump to allow it to run. The pump can pause operation because of alarms, run/stop switch, or an interlock.

Pump Mode

This sets the pump run mode.

Number	Command	Description
0	Pump	Normal operation of pump.
1	Jog Up	Jogs the pump upward.
2	Jog Down	Jogs the pump downward.

Active Profile

This selects the running profile for the pump. 0 is the dynamic profile, and 1-4 are the fixed profiles.

On Off Production

This selects between the off production profile (0) or the on production profile (1).

The on production profile puts the pump into the specified on production profile. This profile puts the pump into normal operating conditions.

The off production profile puts the pump into the specified off production profile. The off production profile usually runs at lower power with the back pressure regulator set to a low value to prevent paint shear.

Clear Event

Setting this from 0 to 1 will clear the latest active event. This should be reset back to 0 when not in use. Internally, the system will reset its internal value to 4294967295 to get ready for the next request.

Digital Output 1 Enable Command (Advanced Only)

Enable digital output 1 on the advanced motor. This feature will only work when the digital output 1 function is configured for Logic Output.

Number	Command	Description
0	Disable	Turns digital output OFF
1	Enable	Turns digital output ON

Digital Output 2 Enable Command (Advanced Only)

Enable digital output 2 on the advanced motor. This feature will only work when the digital output 2 function is configured for Logic Output.

Number	Command	Description
0	Disable	Turns digital output OFF
1	Enable	Turns digital output ON

Analog Output 4-20mA Command

The analog output can be used as a generic 4-20mA output and control any device at the pump. To use this feature, the analog output function must be configured to "None".

Command-Status Data Map

Command	Data Type	Range	Units	User Rights	Description
Pump Enable Command	UINT32	0-1	---	Write	0 = Pump Off 1 = Pump On
Pump Mode Command	UINT32	0-2	---	Write	0 = Pump 1 = Jog Up 2 = Jog Down
Active Profile Command	UINT32	0-4	---	Write	Profile selection 0 = Dynamic profile 1-4 = Fixed profiles
On Off Production Command	UINT32	0-1	---	Write	0 = Off Production 1 = On Production
Clear Event	UINT32	0-1	---	Write	0 = N/A 1 = Clear Active Event
Digital Output 1 Enable Command	UINT32	0-1	---	Write	Only functional when Digital Output Function is set to "Logic Output" 0 = Disable 1 = Enable
Digital Output 2 Enable Command	UINT32	0-1	---	Write	Only functional when Digital Output Function is set to "Logic Output" 0 = Disable 1 = Enable
Analog Output 4-20mA Command	UINT32	0-2500	mA	Write	Only Functional when Analog Output Function is set to "None". 0.00 - 2500 mA

Command-Setup

Auto Restart Command

Pump will resume operation from last active profile after power up (1 = enabled). To operate profile user needs to use fixed profiles 1-4. Profile 0 resets all profile values back to 0 after a power cycle.

Remote Operation Command

When set to 1, the pump will run and stop based on the Run Stop Command over fieldbus. Setting this to 0 disables remote operation, requiring the user to toggle the physical run/stop switch.

Communication Alarm Command

If communication is lost between fieldbus network and DCi Link pump will stop when enabled (1=enabled).

Enable Disable Production Command

When set to 1, the system will use the on/off production profile feature. Setting to 0 disables this feature.

Production Profile Command

This selects which profile number is used while in production mode.

Off Production Profile Command

This selects which profile number is used while in off production mode.

Lower Size Command

Selects the pump lower size in cc.

Closed Loop Pressure Command (Advanced Only)

Closed loop pressure control is enabled (1=enabled).

Digital Input Function 1 and 2 Command (Advanced Only)

The digital input function allows each input to be configured to serve a particular purpose.

For the Digital Inputs, the advanced motor has the following features:

Number	Command	Description
0	None	Not Configured
1	Run/Stop	When input is active (1) the pump will remain in run mode. If the input goes to inactive (0) the pump will pause operation. Purpose is for a user at the station to pause the pump locally.
2	Clear Fault	When input is active (1). The system will try to clear any active fault.
3	Interlock	When input is active (1) the motor will stop operation and enter pump off mode. Interlock must be removed before pump can resume operation.
4	Logic Input	Report status of logic input back to fieldbus network.
5	Jog Up	When input is active the pump will enter Jog Up mode and jog the pump to upper most position. The system will automatically go back to idle once it reaches the top.
6	Jog Down	When input is active the pump will enter Jog Down mode and jog the pump to lower most position. The system will automatically go back to idle once it reaches the bottom.
7	Pump Run	When input is active (1) the pump will enter Pump enabled mode. If profile contains proper values system will resume operation.

Digital Output Function 1 and 2 Command (Advanced Only)

The digital output function allows each output to be configured to serve a particular purpose.

For the Digital Outputs, the advanced motor has the following features:

Number	Command	Description
0	None	Not Configured
1	Pump Running	If the pump is running, then the output will be active. Status bit Pump Active is equal to 1 then 24VDC will be applied.
2	Alarm	If there is an active alarm, then the output will be active. Status bit Active Alarm is equal to 1 then 24VDC will be applied.
3	Logic Output	Digital output can be enabled over the fieldbus to control a user desired function.
4	BPR Output	For simple back pressure regulator systems that don't have pneumatic control and used fixed orifice or fixed restriction to control. If this feature is enabled that Analog Output function of BPR is disabled.

Analog Input 1 Function Command (Advanced Only)

Analog input function allows the user to specify the purpose of the analog input. This was designed for pressure sensor input at the outlet of the pump but can be used as a generic 4-20mA analog input.

Number	Command	Description
0	None	Not Configured
1	Pump Outlet Pressure	Reads the analog input as the pump outlet pressure in user specified units.

Analog Input 1 Process Value 0 Command (Advanced Only)

The process value 0 specifies the value of the sensor at 4mA. This value is usually 0.

Analog Input 1 Process Value 100 Command (Advanced Only)

The process value 100 specifies the value of the sensor at 20mA. This value is the rating of the sensor used.

Analog Input 2 Function Command (Advanced Only)

Analog input function allows the user to specify the purpose of the analog input. This was designed for pressure sensor input at the outlet of the pump but can be used as a generic 4-20mA analog input.

Number	Command	Description
0	None	Not Configured
1	Back Pressure Regulator Pressure	Reads the analog input as the pressure at the back pressure regulator in user specified units.

Analog Input 2 Process Value 0 Command (Advanced Only)

The process value 0 specifies the value of the sensor at 4mA. This value is usually 0.

Analog Input 2 Process Value 100 Command (Advanced Only)

The process value 100 specifies the value of the sensor at 20mA. This value is the rating of the sensor used.

Analog Output Function Command (Advanced Only)

Analog output function allows the user to configure the purpose of the analog output 4-20mA to be used to control a pneumatic BPR controller using a current to pressure transducer.

Number	Command	Description
0	None	Not Configured
1	Back pressure Regulator	Configures analog output to be linked to the active profile back pressure regulator setting.

Command-Setup Data Map

Register Name	Data Type	Range	Units	User Rights	Description
Auto Restart Command	UINT32	0-1	---	Write	0 = Disabled 1 = Enabled
Remote Operation Command	UINT32	0-1	---	Write	0 = Disabled 1 = Enabled
Communication Alarm Command	UINT32	0-1	---	Write	0 = Disabled 1 = Enabled
Enable Disable Production Command	UINT32	0-1	---	Write	0 = Disabled 1 = Enabled
Production Profile Command	UINT32	1-4	---	Write	Selects profile that is used while in production mode.
Off Production Profile Command	UINT32	1-4	---	Write	Select profile that is used while in off production mode.
Lower Size Command	UINT32	0-65535	cc	Write	Selects lower size in cc.
Digital Input Function 1 Command	UINT32	0-7	---	Write	0 = None 1 = Run/Stop 2 = Clear Fault 3 = Interlock 4 = Logic Input 5 = Jog Up 6 = Jog Down 7 = Pump Run
Digital Input Function 2 Command	UINT32	0-7	---	Write	0 = None 1 = Run/Stop 2 = Clear Fault 3 = Interlock 4 = Logic Input 5 = Jog Up 6 = Jog Down 7 = Pump Run
Digital Output Function 1 Command	UINT32	0-4	---	Write	0 = None 1 = Pump Running 2 = Alarm 3 = Logic Output 4 = BPR Output
Digital Output Function 2 Command	UINT32	0-4	---	Write	0 = None 1 = Pump Running 2 = Alarm 3 = Logic Output 4 = BPR Output
Analog Input 1 Function Command	UINT32	0-2	---	Write	0 = None 1 = Pump Pressure 2 = BPR Pressure
Analog Input 1 Process Value 0 Command	UINT32	0-999999	pai, bar, MPa	Write	Process value at 4mA

Register Name	Data Type	Range	Units	User Rights	Description
Analog Input 1 Process Value 100 Command	UINT32	0-999999	pai, bar, MPa	Write	Process value at 20mA
Analog Input 2 Function Command	UINT32	---	---	Write	0 = None 1 = Pump Pressure
Analog Input 2 Process Value 0 Command	UINT32	0-999999	pai, bar, MPa	Write	Process value at 4mA
Analog Input 2 Process Value 100 Command	UINT32	0-999999	pai, bar, MPa	Write	Process value at 20mA
Analog Output Function Command	UINT32	---	---	Write	0 = None 1 = Back Pressure Regulator

Command-Profiles

NOTE: When changing between profiles the system applies a 5 second blanking time before triggering events.

Mode

This indicates the current control mode for the profile.

Number	Mode	Description
0	Force	Maintains the target pump force, regardless of cycle rate (up to the maximum cycle rate).
1	Pressure	Maintains the target pressure at the outlet of the pump (Advanced Only)
2	Flow	Maintains the target flow rate, regardless of pressure (up to the pump's maximum working pressure).

Force Target

This indicates the current force set point for the profile.

Force Minimum Event Value

This indicates the force minimum event value for the profile.

Force Minimum Event Type

This indicates the type for the force minimum event. The event type determines how the system responds if the pump begins to operate below the event value.

Number	Event Type	Description
0	Limit	No action - the system continues to run.
1	Deviation	If force drops below the event value for 1 second, the system will trigger an event notifying the user.
2	Alarm	If force drops below the event value for 1 second, the system will shut down.

Force Maximum Event Value

This indicates the force maximum event value for the profile.

Force Maximum Event Type

This indicates the type for the force maximum event. The event type determines how the system responds if the pump begins to operate above the event value.

Number	Event Type	Description
0	Limit	The system continues to run, reducing the flow rate to prevent exceeding the force limit.
1	Deviation	If force goes above the event value for 1 second, the system will trigger an event notifying the user.
2	Alarm	If force goes above the event value for 1 second, the system will shut down and notify the user.

Pressure Target

This indicates the current pressure setpoint for the profile. The pump will run in closed loop pressure control to the pressure sense at the outlet of the pump.

Pressure Minimum Event Value

This indicates the pressure minimum event value for the profile.

Pressure Minimum Event Type

This indicates the type for the pressure minimum event. The event type determines how the system responds if the pump begins to operate below the event value.

Number	Event Type	Description
0	Limit	No action - the system continues to run.
1	Deviation	If pressure drops below the event value for 1 second, the system will trigger an event notifying the user.
2	Alarm	If pressure drops below the event value for 1 second, the system will shut down.

Pressure Maximum Event Value

This indicates the pressure maximum event value for the profile.

Pressure Maximum Event Type

This indicates the type for the pressure maximum event. The event type determines how the system responds if the pump begins to operate above the event value.

Number	Event Type	Description
0	Limit	The system continues to run, reducing the flow rate to prevent exceeding the pressure limit.
1	Deviation	If pressure goes above the event value for 1 second, the system will trigger an event notifying the user.
2	Alarm	If pressure goes above the event value for 1 second, the system will shut down and notify the user.

Flow Target

This indicates the current flow rate setpoint for the profile.

Flow Minimum Event Value

This indicates the flow rate minimum event value for the profile.

Flow Minimum Event Type

This indicates the type for the flow rate minimum event. The event type determines how the system responds if the pump begins to operate below the event value.

Number	Event Type	Description
0	Limit	No action - the system continues to run.
1	Deviation	If flow rate drops below the event value for 1 second, the system will trigger an event notifying the user.
2	Alarm	If flow rate drops below the event value for 1 second, the system will shut down.

Flow Maximum Event Value

This indicates the flow rate maximum event value for the profile.

Flow Maximum Event Type

This indicates the type for the flow rate maximum event. The event type determines how the system responds if the pump begins to operate above the event value.

Number	Event Type	Description
0	Limit	The system continues to run, reducing the force or pressure to prevent exceeding the flow rate limit.
1	Deviation	If flow rate goes above the event value for 1 second, the system will trigger an event notifying the user.
2	Alarm	If flow rate goes above the event value for 1 second, the system will shut down and notify the user.

BPR Closed Percent Target

This indicates the current back pressure regulator output in % (0% = fully open, 100% = fully closed). This value will control the analog output port (Advanced Only).

Command-Profiles Data Map

Profile # (0-4)	Data Type	Range	Units	User Rights	Description
Mode	UINT32	0-3	---	Write	0 = Force 1 = Pressure 2 = Flow 3 = Hybrid
Force Target	FLOAT	0-100	%	Write	Current force set point in %.
Force Minimum Event Value	FLOAT	0-100	%	Write	Current force minimum event value in %. Must be less than target.
Force Minimum Event Type	UINT32	0-2	---	Write	0 = Limit 1 = Deviation 2 = Alarm
Force Maximum Event Value	FLOAT	0-100	%	Write	Current force maximum event value in %. Must be greater than target.
Force Maximum Event Type	UINT32	0-2	---	Write	0 = Limit 1 = Deviation 2 = Alarm
Pressure Target	FLOAT	0-65535	User-selected flow rate units (GPM, LPM, cc/min, oz/min, CPM)	Write	Pressure setpoint in user-selected pressure units. Maximum value is determined by motor and pump size.
Pressure Minimum Event Value	FLOAT	0-65535	User-selected flow rate units (GPM, LPM, cc/min, oz/min, CPM)	Write	Pressure minimum event value. Must be less than target.
Pressure Minimum Event Type	UINT32	0-2	---	Write	0 = Limit 1 = Deviation 2 = Alarm
Pressure Maximum Event Value	FLOAT	0-65535	User-selected flow rate units (GPM, LPM, cc/min, oz/min, CPM)	Write	Pressure maximum event value. Must be greater than target.
Pressure Maximum Event Type	UINT32	0-2	---	Write	0 = Limit 1 = Deviation 2 = Alarm
Flow Target	FLOAT	0-65535	User-selected flow rate units (GPM, LPM, cc/min, oz/min, CPM)	Write	Current flow rate set point in user-selected flow rate units. Maximum value is determined by motor and pump size.
Flow Minimum Event Value	FLOAT	0-65535	User-selected flow rate units (GPM, LPM, cc/min, oz/min, CPM)	Write	Current flow rate minimum event value in user-selected flow rate units. Must be less than target.

Profile # (0-4)	Data Type	Range	Units	User Rights	Description
Flow Minimum Event Type	UINT32	0-2	---	Write	0 = Limit 1 = Deviation 2 = Alarm
Flow Maximum Event Value	FLOAT	0-65535	User-selected flow rate units (GPM, LPM, cc/min, oz/min, CPM)	Write	Current flow rate maximum event value in user-selected flow rate units. Must be greater than target.
Flow Maximum Event Type	UINT32	0-2	---	Write	0 = Limit 1 = Deviation 2 = Alarm
BPR Closed Percent Target	UINT32	0-100	%	Write	Current back pressure regulator output in % (0% = Open, 100% = Closed).

Command-Maintenance

Maintenance 1-3 Cycles Target

The pump cycles allow the user to specify the number of pump cycles before next service. A cycle is one full stroke up and down. The maintenance target is defaulted to 0 initial. Once the user sets a target, then the total will start counting.

Maintenance 1-3 Days Target

Days allows the user to specify days before next service vs pump cycles. When user has days selected instead of cycles the maintenance total will count in days.

Clear Maintenance

Setting the bit from 0 to 1 clears the maintenance counter. This should be reset back to 0 when not in use. The system will internally reset the value to 4294967295 to not miss the next transition.

Number	Event Type	Description
0	N/A	---
1	Clear Maintenance 1	Clears the maintenance counter for maintenance 1
2	Clear Maintenance 2	Clears the maintenance counter for maintenance 2
3	Clear Maintenance 3	Clears the maintenance counter for maintenance 3

Clear Batch

Setting this from 0 to 1 clears the active batch totals. This should be reset back to 0 when not in use. The system will internally reset the value to 4294967295 to not miss the next transition.

Command-Maintenance Data Map

Register Name	Data Type	Range	Units	User Rights	Description
Maintenance Target 1 Cycles Command	UINT32	0-4294967295	Cycles	Write	Maintenance target 1 in pump cycles.
Maintenance Target 2 Cycles Command	UINT32	0-4294967295	Cycles	Write	Maintenance target 2 in pump cycles.
Maintenance Target 3 Cycles Command	UINT32	0-4294967295	Cycles	Write	Maintenance target 3 in pump cycles.
Maintenance Target 1 Days Command	UINT32	0-4294967295	Days	Write	Maintenance target 1 in days.
Maintenance Target 2 Days Command	UINT32	0-4294967295	Days	Write	Maintenance target 2 in days.
Maintenance Target 3 Days Command	UINT32	0-4294967295	Days	Write	Maintenance target 3 in days.
Clear Maintenance	UINT32	0-1	---	Write	0: N/A 1: Clear Maintenance 1 2: Clear Maintenance 2 3: Clear Maintenance 3
Clear Batch	UINT32	0-1	---	Write	0: N/A 1: Clear Active Event

DCi Link Data

Status-Module

Pump 1 Comm Status

This indicates the current communication status for pump 1. When 0, a pump communication alarm is active. When 1, the pump is communicating successfully.

Status-Module Data Map

Register Name	Data Type	Range	Units	User Rights	Description
Pump 1 Comm Status	UINT32	0-1	-	Read	Current communication status: 0 = Pump Comm Alarm 1 = Pump Comm OK

Status-I/O

Digital Input # (1-4)

Indicates the current digital input # signal as 0 or 1.

Digital Output # (1-4)

Indicates the current digital output # signal as 0 or 1.

Analog Input 4-20 mA

Indicates the current analog current input signal as mA * 100 (e.g. 2000 = 20mA).

Analog Input 0-10 V

Indicates the current analog voltage input signal as V * 10 (e.g. 100 = 10V).

Analog Output 4-20 mA

Indicates the current analog current output signal as mA * 100 (e.g. 2000 = 20mA).

Pressure Sensor

Indicates the current pressure sensor reading in user-selected pressure units. The value resolution changes depending on which units are selected.

BPR Output

Indicates the current BPR output signal in percent.

Status-I/O Data Map

Register Name	Data Type	Range	Units	User Rights	Description
Digital Input # (1-4)	UINT32	0-1	-	Read	
Digital Output # (1-4)	UINT32	0-1	-	Read	
Analog Input 4-20 mA	UINT32	0-2000	mA	Read	2000 = 20 mA
Analog Input 0-10 V	UINT32	0-2000	V	Read	100 = 10 V
Analog Output 4-20 mA	UINT32	0-2000	mA	Read	2000 = 20 mA
Pressure Sensor	UINT32	0-100000	PSI, bar, MPa	Read	100000 = 10,000.0 PSI 100000 = 1,000.00 bar 100000 = 100.000 MPa
BPR Output	UINT32	0-100	%	Read	

Setup-General

Digital Input # (1-4) Function

These registers indicate the configured function of each digital input.

Number	Function
0	None
1	Run/Stop Switch
2	Clear Fault
3	Interlock
4	Logic Input
5	Jog Up
6	Jog Down
7	Pump Run

Digital Output # (1-4) Function

These registers indicate the configured function of each digital output.

Number	Function
0	None
1	Pump Running
2	Alarm
3	Logic Output

Setup-General Data Map

Register Name	Data Type	Range	Units	User Rights	Description
Digital Input # (1-4) Function	UINT32	0-8	-	Read	0 = Not configured 1 = Run/Stop Switch 2 = Clear Fault 3 = Interlock 4 = Logic Input 5 = Jog Up 6 = Jog Down 7 = Interlock 8 = Pump Run
Digital Output # (1-4) Function	UINT32	0-6	-	Read	0 = Not configured 1 = Pump Running 2 = Alarm 3 = Logic Output

Setup-Pressure Sensor

Process Variable at 0

This indicates the corresponding pressure value for the analog input signal at 0%.

Process Variable at 100

This indicates the corresponding pressure value for the analog input signal at 100%.

Setup-Pressure Sensor Data Map

Register Name	Data Type	Range	Units	User Rights	Description
Process Variable at 0	UINT32	0-4294967295	PSI, bar, MPa	Write	Specify the 0% process value for the 4-20mA input
Process Variable at 100	UINT32	0-4294967295	PSI, bar, MPa	Write	Specify the 100% process value for the 4-20mA input

Setup-Units

Flow Rate

Number	Function
0	Gallons/min
1	Liters/min
2	cc/min
3	oz/min
4	Cycles/min

Pressure

Number	Function
0	PSI
1	bar
2	MPa

Volume

Number	Function
0	Gallons
1	Liters

Setup-Units Data Map

Register Name	Data Type	Range	Units	User Rights	Description
Flow Rate	UINT32	0-4	-	Write	0 = Gallons/min 1 = Liters/min 2 = cc/min 3 = oz/min 4 = Cycles/min
Pressure	UINT32	0-2	-	Write	0 = PSI 1 = bar 2 = MPa
Volume	UINT32	0-1	-	Write	0 = Gallons 1 = Liters

Scheduler

(SYSTEM > Schedule)

Schedule

Pump Profile
ON OFF
0 0

Scheduler Mode :

Manual Override :

Weekend Mode :

Time Slot	Monday	Tuesday	Wednesday	Thursday	Friday	Saturday	Sunday
#1	00:00	00:00	00:00	00:00	00:00	00:00	00:00
#2	01:00	01:00	01:00	01:00	01:00	00:00	00:00
#3	00:00	00:00	00:00	00:00	00:00	00:00	00:00
#4	00:00	00:00	00:00	00:00	00:00	00:00	00:00
#5	00:00	00:00	00:00	00:00	00:00	00:00	00:00
#6	00:00	00:00	00:00	00:00	00:00	00:00	00:00

FIG. 48: Pump Maintenance Form

Pump Profile

Identifies which Pump Profile is in Production or Off Production.

Scheduler Mode

Enables the Scheduler with the active Time Slots for Pump Profiles.

Manual Override

Allows the user to manually set a day and time slot to Production or Off Production for a Pump Profile.

Weekend Mode

Sets all current Saturday and Sunday times to Off Production.

Time Slots

Each day offers up to six different time slots to toggle between Production and Off Production.

Dimensions

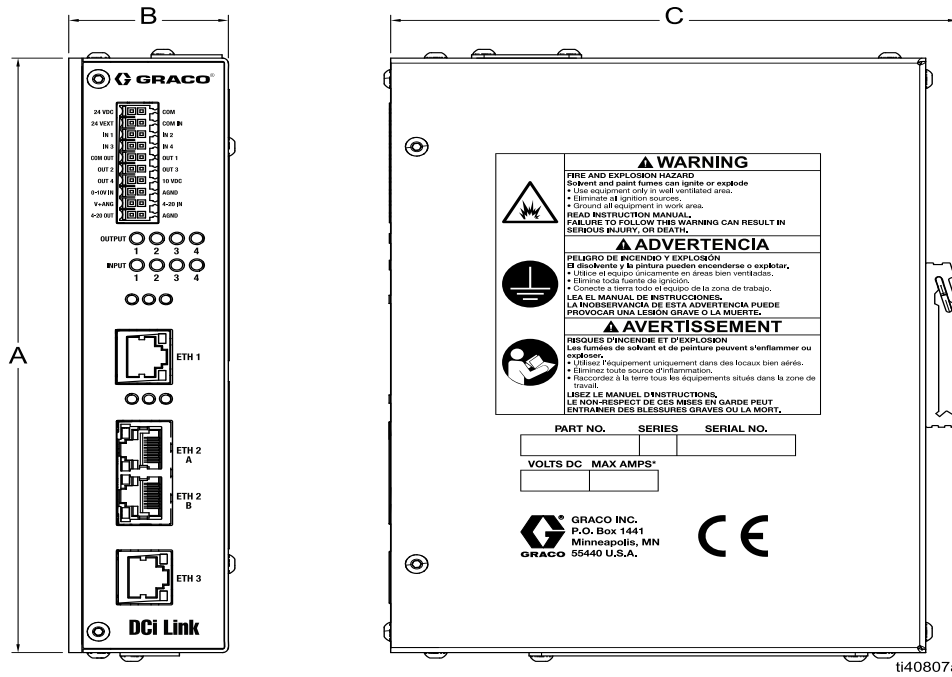

A	B	C
7.33 in. (186.18 mm)	1.66 in. (42.16 mm)	5.57 in. (141.48 mm)

Technical Specifications

E-Flo DCi Link		
	US	Metric
Power Requirements		
Voltage	24 VDC	
Current	300 mA	
Digital Inputs		
Inputs	4	
Voltage Category	24 VDC Sinking or Sourcing	
Operating Voltage Range	10 – 30 VDC	
Input Voltage Nominal	24 VDC	
Current draw @ 24V DC	0.02A per input	
Power Dissipation, max	50mW per input	
Digital Outputs		
Outputs	4	
Voltage Category	24V DC Sourcing	
Operating Voltage Range	10 – 30V DC	
Output Delay Time	<1mS	
Current per point	0.2A per output	
Power Dissipation, max	10 mW per output	
<ul style="list-style-type: none"> Inductive Load compatible 		

Analog Inputs		
Analog Input 0-10 V		
Resolution	12 bit	
Input Voltage	0-10 V	
Allowable Potentiometer Resistance Range	1 to 10 kΩ	
Analog Input 4-20 mA		
Resolution	16 Bit	
Type	Low Side Sinking	
Load	100 Ω	
Analog Outputs		
Analog Output 4-20 mA		
Maximum Load	525 Ω (10.5 V)	
Temperature Rating	32-104°F	0-40°C
Enclosure Rating	IP2X	
Din Rail Mounting	1.38 in.	35 mm
Web Interface Connection	RJ45 Ethernet Port	
Fieldbus		
Connection	dual RJ45 Ethernet port	
Protocols	Modbus TCP, EtherNet/IP, PROFINET	
Weight	1.3 lb	0.59 kg

California Proposition 65

CALIFORNIA RESIDENTS

 **WARNING:** Cancer and reproductive harm – www.P65warnings.ca.gov.

Graco Standard Warranty

Graco warrants all equipment referenced in this document which is manufactured by Graco and bearing its name to be free from defects in material and workmanship on the date of sale to the original purchaser for use. With the exception of any special, extended, or limited warranty published by Graco, Graco will, for a period of twelve months from the date of sale, repair or replace any part of the equipment determined by Graco to be defective. This warranty applies only when the equipment is installed, operated and maintained in accordance with Graco's written recommendations.

This warranty does not cover, and Graco shall not be liable for general wear and tear, or any malfunction, damage or wear caused by faulty installation, misapplication, abrasion, corrosion, inadequate or improper maintenance, negligence, accident, tampering, or substitution of non-Graco component parts. Nor shall Graco be liable for malfunction, damage or wear caused by the incompatibility of Graco equipment with structures, accessories, equipment or materials not supplied by Graco, or the improper design, manufacture, installation, operation or maintenance of structures, accessories, equipment or materials not supplied by Graco.

This warranty is conditioned upon the prepaid return of the equipment claimed to be defective to an authorized Graco distributor for verification of the claimed defect. If the claimed defect is verified, Graco will repair or replace free of charge any defective parts. The equipment will be returned to the original purchaser transportation prepaid. If inspection of the equipment does not disclose any defect in material or workmanship, repairs will be made at a reasonable charge, which charges may include the costs of parts, labor, and transportation.

THIS WARRANTY IS EXCLUSIVE, AND IS IN LIEU OF ANY OTHER WARRANTIES, EXPRESS OR IMPLIED, INCLUDING BUT NOT LIMITED TO WARRANTY OF MERCHANTABILITY OR WARRANTY OF FITNESS FOR A PARTICULAR PURPOSE.

Graco's sole obligation and buyer's sole remedy for any breach of warranty shall be as set forth above. The buyer agrees that no other remedy (including, but not limited to, incidental or consequential damages for lost profits, lost sales, injury to person or property, or any other incidental or consequential loss) shall be available. Any action for breach of warranty must be brought within two (2) years of the date of sale.

GRACO MAKES NO WARRANTY, AND DISCLAIMS ALL IMPLIED WARRANTIES OF MERCHANTABILITY AND FITNESS FOR A PARTICULAR PURPOSE, IN CONNECTION WITH ACCESSORIES, EQUIPMENT, MATERIALS OR COMPONENTS SOLD BUT NOT MANUFACTURED BY GRACO. These items sold, but not manufactured by Graco (such as electric motors, switches, hose, etc.), are subject to the warranty, if any, of their manufacturer. Graco will provide purchaser with reasonable assistance in making any claim for breach of these warranties.

In no event will Graco be liable for indirect, incidental, special or consequential damages resulting from Graco supplying equipment hereunder, or the furnishing, performance, or use of any products or other goods sold hereto, whether due to a breach of contract, breach of warranty, the negligence of Graco, or otherwise.

FOR GRACO CANADA CUSTOMERS

The Parties acknowledge that they have required that the present document, as well as all documents, notices and legal proceedings entered into, given or instituted pursuant hereto or relating directly or indirectly hereto, be drawn up in English. Les parties reconnaissent avoir convenu que la rédaction du présente document sera en Anglais, ainsi que tous documents, avis et procédures judiciaires exécutés, donnés ou intentés, à la suite de ou en rapport, directement ou indirectement, avec les procédures concernées.

Graco Information

For the latest information about Graco products, visit www.graco.com.

For patent information, see www.graco.com/patents.

TO PLACE AN ORDER, contact your Graco distributor or call to identify the nearest distributor.

Toll Free Phone Number: 1-800-328-0211

*All written and visual data contained in this document reflects the latest product information available at the time of publication.
Graco reserves the right to make changes at any time without notice.*

Original instructions. This manual contains English. MM 3A8471

Graco Headquarters: Minneapolis

International Offices: Belgium, China, Japan, Korea

GRACO INC. AND SUBSIDIARIES • P.O. BOX 1441 • MINNEAPOLIS MN 55440-1441 • USA
Copyright 2023, Graco Inc. All Graco manufacturing locations are registered to ISO 9001.

www.graco.com
Revision D, August 2025