

Paint Resistivity Meter

3A9405C

EN

For measuring electrical resistivity of paint used for electrostatic coating. For professional use only.

Not approved for use in explosive atmospheres and hazardous (classified) locations.

2002584 - Meter (includes 722860 Probe, 2002582 Meter Cable, and 2014109 Test Fixture)

2011042 - Meter (includes 2002582 Cable, and 2014109 Test Fixture)

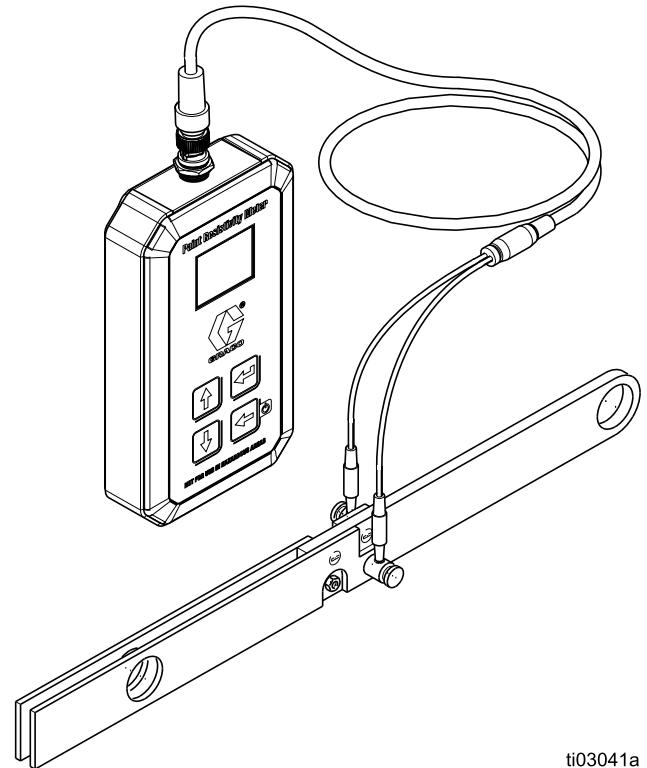

Important Safety Instructions

Read all warnings and instructions in this manual before using the equipment. Be familiar with the proper control and usage of the equipment. Save these instructions.





ti03041a





Contents

Contents	2	Operation	12
Safety Symbols	3	Power On	12
General Warnings	4	Measure the Resistivity	12
Overview	6	Display Screen Colors	12
Installation	7	Power Off	12
Typical Installation	7	Calibration	13
Assembly: Connecting Meter, Probe, and Cable.	8	Dimensions	14
Battery Installation Procedure	9	Technical Specifications	15
Controls and Screens	10	Graco Standard Warranty	16
Home screen	10		
Menu	10		

Safety Symbols

The following safety symbols appear throughout this manual and on warning labels. Read the table below to understand what each symbol means.

Symbol	Meaning
	Equipment Misuse Hazard
	Fire and Explosion Hazard
	Pressurized Equipment Hazard
	Toxic Fluid or Fumes Hazard
	Ground Equipment

Symbol	Meaning
	Follow Pressure Relief Procedure
	Ventilate Work Area
	Wear Personal Protective Equipment
	Eliminate Ignition Sources













Safety Alert Symbol

This symbol indicates: Attention! Become Alert! Look for this symbol throughout the manual to indicate important safety messages.

General Warnings

The following warnings apply throughout this manual. Read, understand, and follow the warnings before using this equipment. Failure to follow these warnings can result in serious injury.

 <h2 style="margin: 0;">WARNING</h2>	
   	<p>FIRE AND EXPLOSION HAZARD</p> <p>Flammable fumes, such as solvent and paint fumes, in work area can ignite or explode. Paint or solvent flowing through the equipment can cause static sparking. To help prevent fire and explosion:</p> <ul style="list-style-type: none"> • Use equipment only in well-ventilated area. • Eliminate all ignition sources, such as pilot lights, cigarettes, portable electric lamps, and plastic drop cloths (potential static sparking). • Ground all equipment in the work area. • Never spray or flush solvent at high pressure. • Keep work area free of debris, including solvent, rags and gasoline. • Do not plug or unplug power cords, or turn power or light switches on or off when flammable fumes are present. • Use only grounded hoses. • Hold gun firmly to side of grounded pail when triggering into pail. Do not use pail liners unless they are anti-static or conductive. • Stop operation immediately if static sparking occurs or you feel a shock. Do not use equipment until you identify and correct the problem. • Keep a working fire extinguisher in the work area.
 	<p>EQUIPMENT MISUSE HAZARD</p> <ul style="list-style-type: none"> • Misuse can cause death or serious injury. • Do not operate the unit when fatigued or under the influence of drugs or alcohol. • Do not exceed the maximum working pressure or temperature rating of the lowest rated system component. See Technical Specifications in all equipment manuals. • Use fluids and solvents that are compatible with equipment wetted parts. See Technical Specifications in all equipment manuals. Read fluid and solvent manufacturer's warnings. For complete information about your material, request Safety Data Sheets (SDSs) from distributor or retailer. • Do not leave the work area while equipment is energized or under pressure. • Turn off all equipment and follow the Pressure Relief Procedure when equipment is not in use. • Check equipment daily. Repair or replace worn or damaged parts immediately with genuine manufacturer's replacement parts only. • Do not alter or modify equipment. Alterations or modifications may void agency approvals and create safety hazards. • Make sure all equipment is rated and approved for the environment in which you are using it. • Use equipment only for its intended purpose. Call your distributor for information. • Route hoses and cables away from traffic areas, sharp edges, moving parts, and hot surfaces. • Do not kink or over bend hoses or use hoses to pull equipment. • Keep children and animals away from work area. • Comply with all applicable safety regulations.

 <h1 style="margin: 0;">WARNING</h1>	
	<p>TOXIC FLUID OR FUMES HAZARD</p> <p>Toxic fluids or fumes can cause serious injury or death if splashed in the eyes or on skin, inhaled, or swallowed.</p> <ul style="list-style-type: none"> • Read Safety Data Sheets (SDSs) to know the specific hazards of the fluids you are using. • Store hazardous fluid in approved containers, and dispose of it according to applicable guidelines.
	<p>PERSONAL PROTECTIVE EQUIPMENT</p> <p>Wear appropriate protective equipment when in the work area to help prevent serious injury, including eye injury, hearing loss, inhalation of toxic fumes, and burns. Protective equipment includes but is not limited to:</p> <ul style="list-style-type: none"> • Protective eyewear, and hearing protection. • Respirators, protective clothing, and gloves as recommended by the fluid and solvent manufacturer.

Overview

The Graco Paint Resistivity Meter is an essential tool used in the coatings industry to measure the electrical resistivity of paint. The resistivity of paint is a critical parameter, especially in applications like electrostatic spray painting, where it influences how well the paint adheres to the surface and how uniformly it is applied.

Major Components of the Paint Resistivity Meter

The Paint Resistivity Meter consist of two main parts:

1. **Probe:** The probe is a crucial component responsible for interfacing with the paint. It is designed to be immersed in the paint sample and is made from materials that resist corrosion and chemical interaction with the paint. The probe consists of two electrodes that are positioned at a fixed distance from each other. These electrodes measure the voltage drop across the paint when a known current is passed through it.

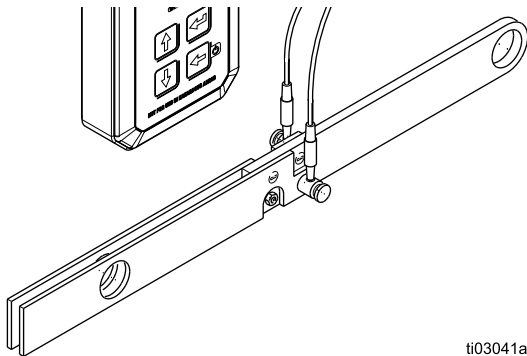

ti03041a

FIG. 1: Probe

2. **Meter:** The meter houses the electronics, batteries, and the display. It calculates the resistivity of paint in Megohm-centimeters.

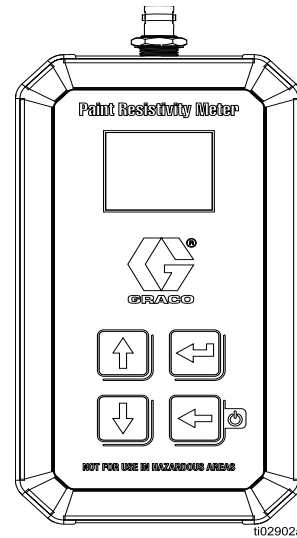

ti02902a

FIG. 2: Meter

Installation

Carefully unbox the Graco Paint Resistivity Meter and all its components: the probe, cable, and meter.

NOTICE

Do not damage the probe, as this may bend the electrodes and affect the accuracy of the meter readings.

Typical Installation

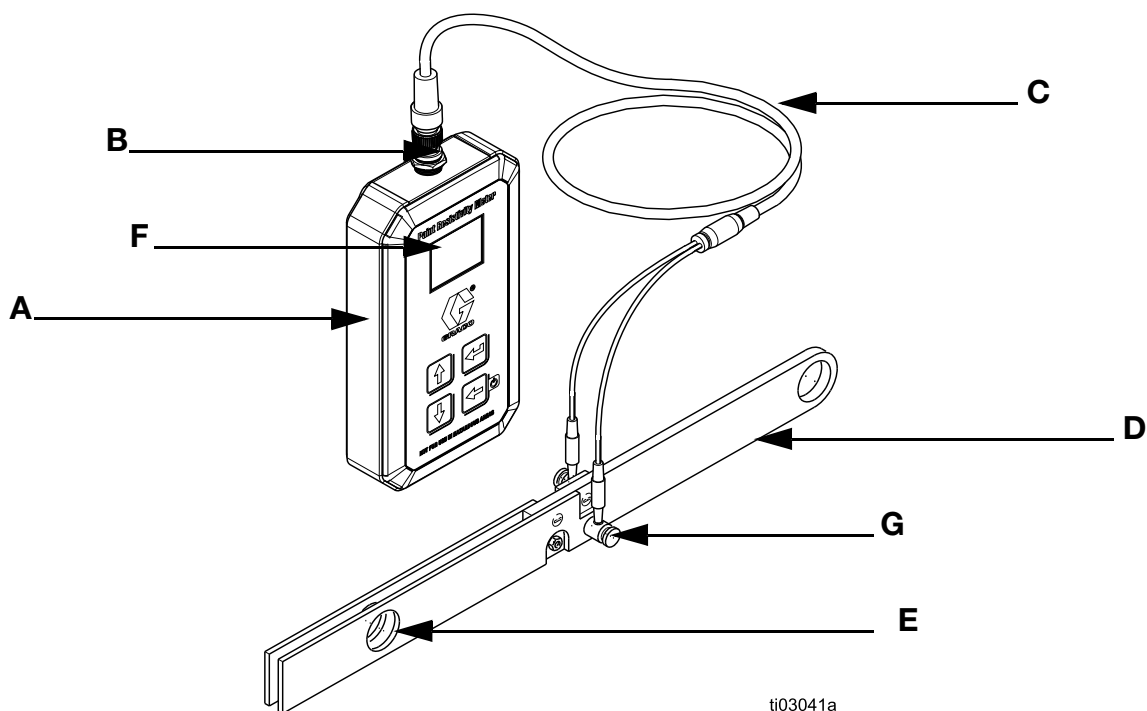

FIG. 3: Typical Installation

Key:

- A Meter
- B Connector Port
- C Meter Cable
- D Probe
- E Center Holes
- F Display
- G Probe Meter Cable Pin Connectors

Assembly: Connecting Meter, Probe, and Cable

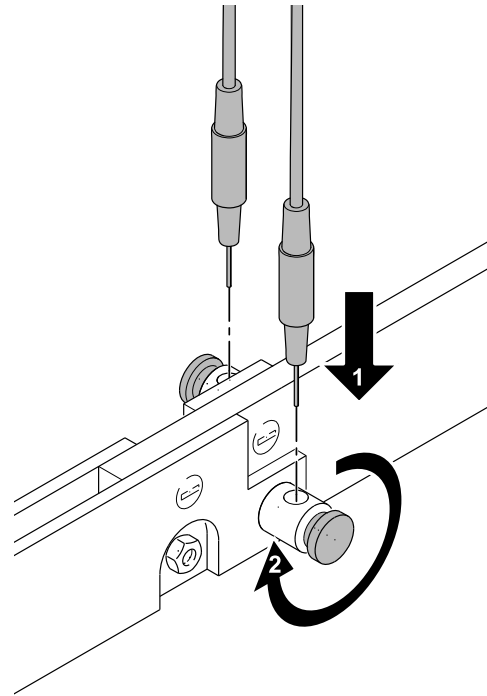
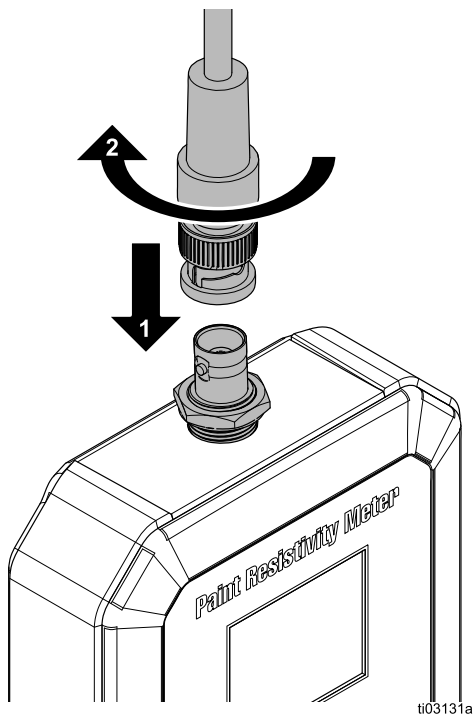

FIG. 4

Connecting the Meter Cable to the Meter and Probe

Connect the cable at the port and the probe as shown in the figure above. Verify the cable is securely attached at both ends.

Battery Installation Procedure

The paint resistivity meter uses four AA batteries and is also compatible with AA rechargeable batteries rated between 1.2V and 1.5V.

Note: Ensure that the batteries installed are new. Lower mAh batteries will start with a <100% reading on the display. It is recommended to replace the battery if the charge falls below 5%.

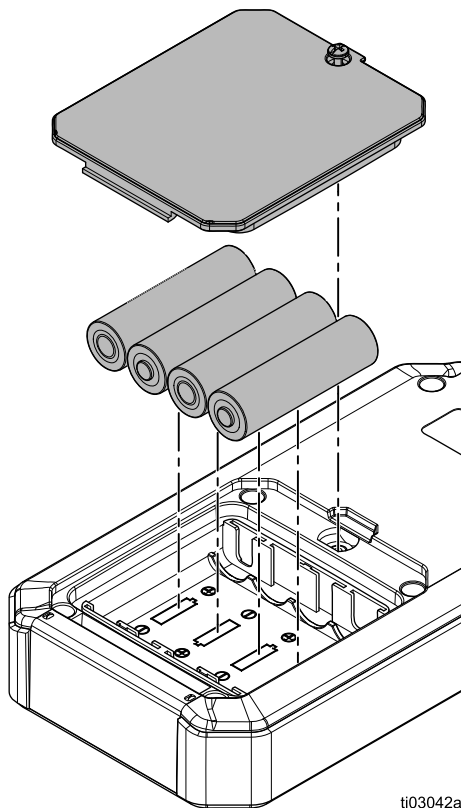

ti03042a

FIG. 5

Controls and Screens

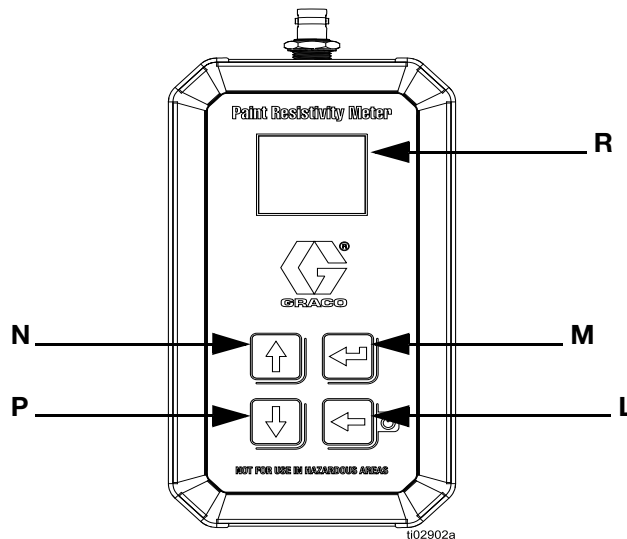

FIG. 6

Key:

- L Back key (Power on)
- M Enter key
- N Up key
- P Down key
- R Display Screen

Menu

Press the **Enter** key (M) to display the menu. The menu will display the following options:

1. **Settings**
2. **Calibration**
3. **Device Information**
4. **Power Off**

Home screen

Home screen provide the details, date, time, battery level, and unit of measurement.

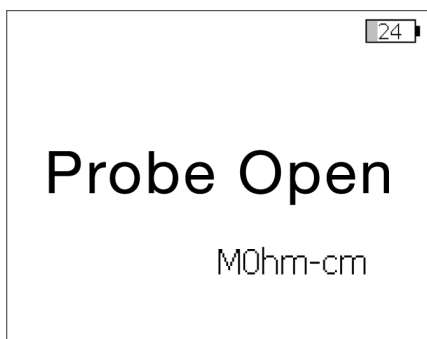

FIG. 7

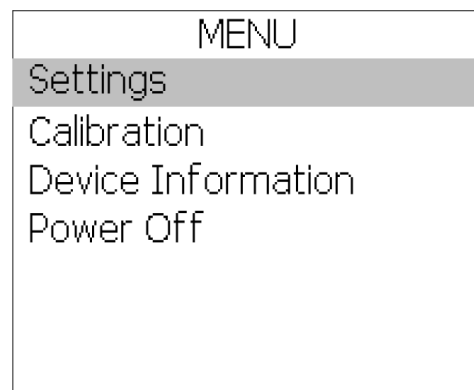

FIG. 8

When the main menu is displayed (refer to Fig. 6), use the navigation buttons (up/down keys N and P) to scroll through the available options.

Settings

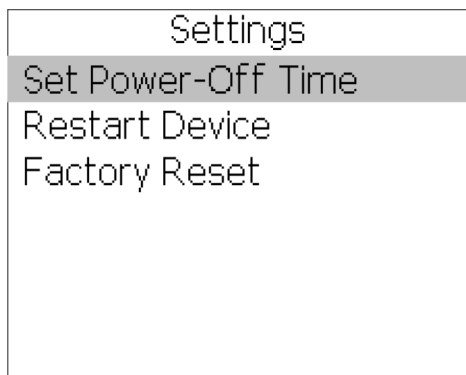

FIG. 9

The settings will display the following options:

1. Set Power-Off Time
2. Restart Device
3. Factory Reset

3. Set Power-Off Time

Configure the automatic power-off time to conserve battery life. The meter will turn off automatically after a set period of inactivity. Factory setting is 5 minutes.

- Enter the Settings menu.
- Select Set Power-Off Time.
- Choose the desired time (e.g., 5 minutes, 10 minutes, 30 minutes). Maximum setting is 59 minutes.
- Confirm the selection with the **Enter** key (M) button.

4. Restart Device

Soft reset the meter without losing any saved settings or data. Use this option if the meter is not responding or functioning correctly.

- Select Restart Device.
- Confirm the action by selecting Yes when prompted. The meter will reboot.

5. Factory Reset

Restore the meter to its original factory settings. All custom settings and stored data will be erased.

- Scroll to Factory Reset.
- Select Factory Reset and confirm by selecting Yes when prompted.
- The meter will reset and restart, returning all settings to default.

Calibration

See **Measure the Resistivity**, page 12.

Device Information

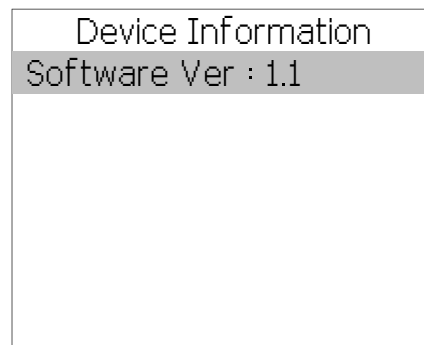

FIG. 10

To view the software version of the meter:



1. Navigate to the Settings menu.
2. Select Device Information.
3. The software version will be displayed on the screen.

Power Off

To manually power off the meter through the settings:

1. Go to the Settings menu using the directional buttons.
2. Scroll down and select Power Off. Pressing the **Enter** key (M) will shut down the meter immediately.

Operation

				
<p>Read material manufacturer's warnings and Safety Data Sheets (SDSs).</p> <p>This meter must not be used in hazardous areas. All flammable material must be kept in approved grounded containers.</p>				

- Once the probe is properly positioned in the solution, press Back key (L) the meter will begin measuring the resistivity of the solution.
- The resistivity value of the solution will be displayed on the screen in Megohm-centimeters.
- The best electrostatic result are achieved when the resistivity of the material is above 25 Megohm-centimeters.

Power On

Press and hold the **Back** key (L), until the Graco logo "G" appears on the screen.

Measure the Resistivity

- Before taking any measurements, verify that the meter is calibrated. Refer **Calibration**, page 13.
- Ensure that the probe, meter and cables are securely connected, See **Installation**, page 7.
- Pour the solution you want to measure into a clean container.
- Dip the probe into the solution, ensuring that the hole in the probe is half-immersed in the liquid.

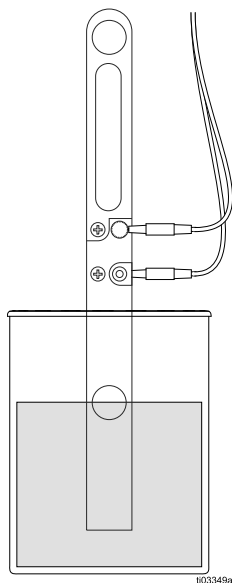

FIG. 11

Display Screen Colors

- Materials with resistivity readings in the green-colored display screen will give the best electrostatic results.
- Materials with resistivity readings in the yellow-colored display screen will give reduced electrostatic performance. The lower resistivity reading the lower the electrostatic performance. Materials with resistivity readings between 7-15 Megohms-cm should be avoided if possible.
- Solvent base materials with resistivity readings displayed in the red-colored display screen will ground out the charging electrode due to current flow through the material column. The electrostatic effect will be reduced to a low level. Water-base materials can be used with Graco water-base conversion kits and accessories regardless of their resistivity reading.

Power Off

Power off the meter manually by selecting the Power Off option in the Settings menu, see **Power Off**, page 11, or the meter will automatically power off at the **Set Power-Off Time** page 11.

Calibration

1. The meter should not need to be calibrated differently compared to the factory set calibration. If the meter reading is questionable, first perform a factory reset, page 11, and retest the resistivity of the material. To confirm the resistivity meter is reading per factory settings, use Test Fixture 2014109 to check resistivity readings. See FIG. 12 below. Insert the probe into each of the slots making sure the ends of the probes touch the wires in the slots, and take a resistivity reading. The readings should closely match the numbers on the test fixture (20, 44, 89) (+/- 3 mega-ohm centimeters). If different calibration settings are required, follow the steps below.
2. **Select the Standard Solution:** Use a standard resistivity solution with a known resistivity value.
3. Clean the probe thoroughly to remove any contaminants that could affect calibration accuracy.
4. Immerse the probe in the standard solution until the hole in the probe is submerged halfway. Ensure proper contact between the probe and the solution at this depth to achieve an accurate measurement.
5. **Navigate to the Calibration Option:** Scroll to Calibration in the main menu using the arrow keys, then press Enter.
6. Select **Set Known Resistivity** and press the Enter key (M).
7. The default resistivity is displayed as 0000. Use the Up key (N) and Down key (P) to set the known resistivity in MOhm-cm of the solution.
8. Press Save & Next.
9. Press the Enter key (M) to read the measurement.

10. The display will show a Success message.

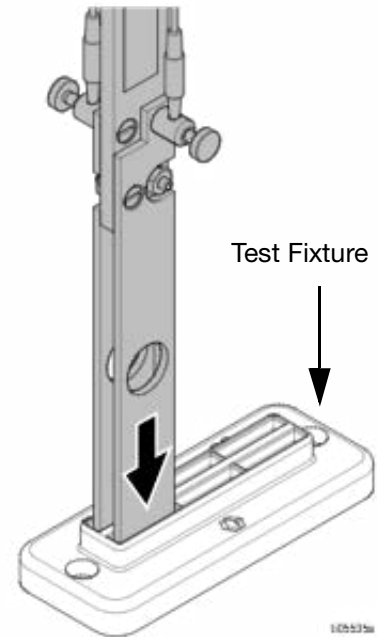

FIG. 12

Dimensions

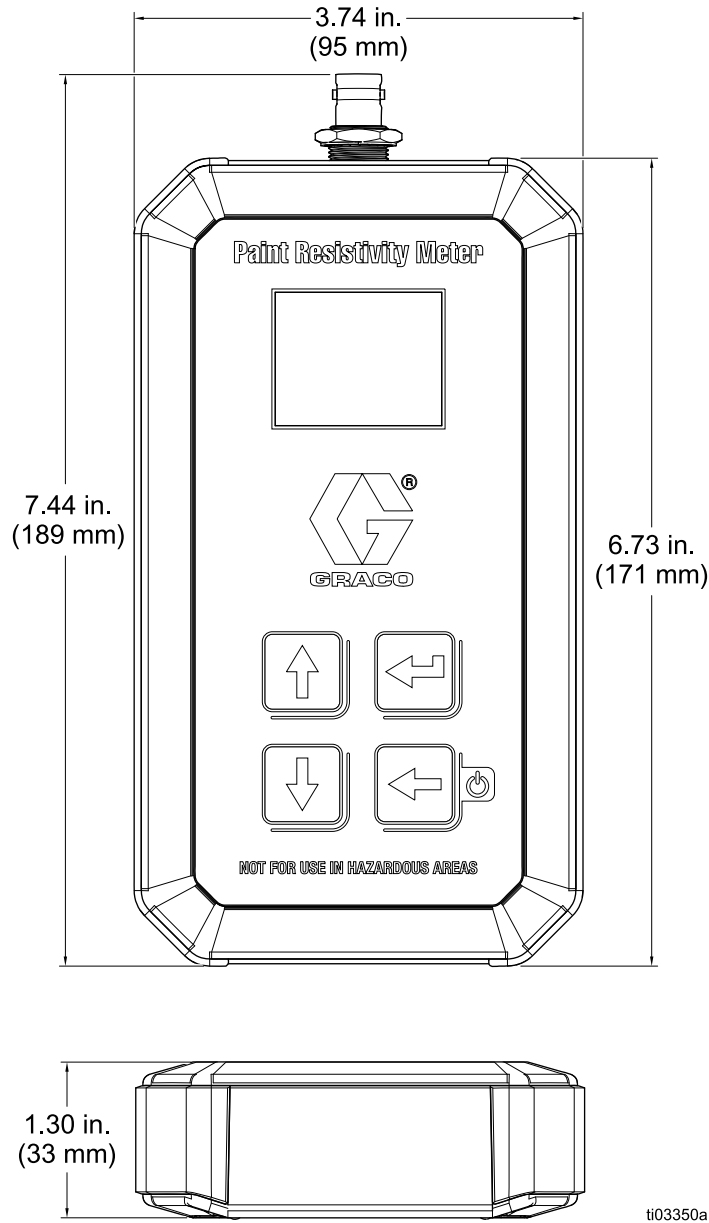

FIG. 13

Technical Specifications

Paint Resistivity Meter		
	US	Metric
Batteries	AA (Qty 4) (2850 mAh minimum recommended)	
Operating temperature range	32°–122°F	0°–50°C
Storage temperature range	-22°–140°F	-30°–60°C
Materials of Construction		
Probe Wetted Parts	Chrome Plated Aluminum	
Enclosure degree of protection	IP51	
Weight		
Meter weight (with cable, probe, and batteries)	1.3 lb.	0.6 kg

California Proposition 65

CALIFORNIA RESIDENTS

 **WARNING:** Cancer and reproductive harm. – www.P65warnings.ca.gov.

Graco Standard Warranty

Graco warrants all equipment referenced in this document which is manufactured by Graco and bearing its name to be free from defects in material and workmanship on the date of sale to the original purchaser for use. With the exception of any special, extended, or limited warranty published by Graco, Graco will, for a period of twelve months from the date of sale, repair or replace any part of the equipment determined by Graco to be defective. This warranty applies only when the equipment is installed, operated and maintained in accordance with Graco's written recommendations.

This warranty does not cover, and Graco shall not be liable for general wear and tear, or any malfunction, damage or wear caused by faulty installation, misapplication, abrasion, corrosion, inadequate or improper maintenance, negligence, accident, tampering, or substitution of non-Graco component parts. Nor shall Graco be liable for malfunction, damage or wear caused by the incompatibility of Graco equipment with structures, accessories, equipment or materials not supplied by Graco, or the improper design, manufacture, installation, operation or maintenance of structures, accessories, equipment or materials not supplied by Graco.

This warranty is conditioned upon the prepaid return of the equipment claimed to be defective to an authorized Graco distributor for verification of the claimed defect. If the claimed defect is verified, Graco will repair or replace free of charge any defective parts. The equipment will be returned to the original purchaser transportation prepaid. If inspection of the equipment does not disclose any defect in material or workmanship, repairs will be made at a reasonable charge, which charges may include the costs of parts, labor, and transportation.

THIS WARRANTY IS EXCLUSIVE, AND IS IN LIEU OF ANY OTHER WARRANTIES, EXPRESS OR IMPLIED, INCLUDING BUT NOT LIMITED TO WARRANTY OF MERCHANTABILITY OR WARRANTY OF FITNESS FOR A PARTICULAR PURPOSE.

Graco's sole obligation and buyer's sole remedy for any breach of warranty shall be as set forth above. The buyer agrees that no other remedy (including, but not limited to, incidental or consequential damages for lost profits, lost sales, injury to person or property, or any other incidental or consequential loss) shall be available. Any action for breach of warranty must be brought within two (2) years of the date of sale.

GRACO MAKES NO WARRANTY, AND DISCLAIMS ALL IMPLIED WARRANTIES OF MERCHANTABILITY AND FITNESS FOR A PARTICULAR PURPOSE, IN CONNECTION WITH ACCESSORIES, EQUIPMENT, MATERIALS OR COMPONENTS SOLD BUT NOT MANUFACTURED BY GRACO. These items sold, but not manufactured by Graco (such as electric motors, switches, hose, etc.), are subject to the warranty, if any, of their manufacturer. Graco will provide purchaser with reasonable assistance in making any claim for breach of these warranties.

In no event will Graco be liable for indirect, incidental, special or consequential damages resulting from Graco supplying equipment hereunder, or the furnishing, performance, or use of any products or other goods sold hereto, whether due to a breach of contract, breach of warranty, the negligence of Graco, or otherwise.

FOR GRACO CANADA CUSTOMERS

The Parties acknowledge that they have required that the present document, as well as all documents, notices and legal proceedings entered into, given or instituted pursuant hereto or relating directly or indirectly hereto, be drawn up in English. Les parties reconnaissent avoir convenu que la rédaction du présente document sera en Anglais, ainsi que tous documents, avis et procédures judiciaires exécutés, donnés ou intentés, à la suite de ou en rapport, directement ou indirectement, avec les procédures concernées.

Graco Information

For the latest information about Graco products, visit www.graco.com.

For patent information, see www.graco.com/patents.

TO PLACE AN ORDER, contact your Graco distributor or call to identify the nearest distributor.

Toll Free Phone Number: 1-800-328-0211

*All written and visual data contained in this document reflects the latest product information available at the time of publication.
Graco reserves the right to make changes at any time without notice.*

Original instructions. This manual contains English. MM 3A9405

Graco Headquarters: Minneapolis

International Offices: Belgium, China, Japan, Korea

GRACO INC. AND SUBSIDIARIES • P.O. BOX 1441 • MINNEAPOLIS MN 55440-1441 • USA
Copyright 2023, Graco Inc. All Graco manufacturing locations are registered to ISO 9001.

www.graco.com
Revision C, November 2025