

# Double Wall Heated Hopper

3A6110C

EN

*For use with XM™ and XPs-hf™ plural-component sprayers. For professional use only.*

*Not for use in European explosive atmospheres.*

**26C482, Double Wall Heated Hopper, 240V**

**26B279, Double Wall Heated Hopper, 480V**

25 Gallon (94.6 L) Material Capacity

12 Gallon (45.4 L) Heating Fluid Capacity



## Important Safety Instructions

Read all warnings and instructions in this manual and in your proportioner manual before using the equipment. Save these instructions.

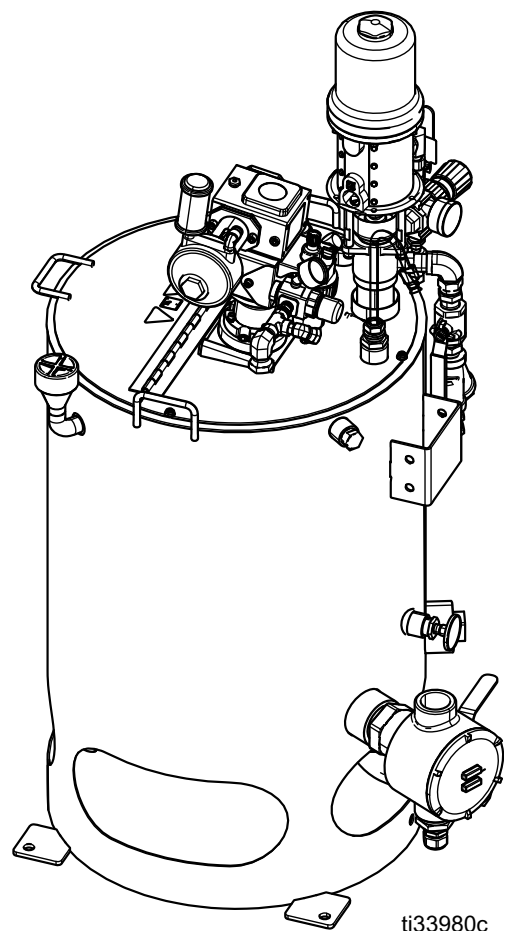







# Contents

<b>Related Manuals</b> .....	<b>2</b>	Agitators (ED) .....	<b>14</b>
<b>Component Approvals</b> .....	<b>2</b>	Feed Pumps (EE) .....	<b>14</b>
<b>Safety Symbols</b> .....	<b>3</b>	<b>Troubleshooting</b> .....	<b>15</b>
<b>Warnings</b> .....	<b>4</b>	<b>Repair</b> .....	<b>17</b>
<b>Important Isocyanate (ISO) Information</b> .....	<b>7</b>	Immersion Heater .....	<b>17</b>
Isocyanate Conditions .....	7	Agitator .....	18
Keep Components A and B Separate .....	7	Feed Pump .....	19
Moisture Sensitivity of Isocyanates .....	8	Feed Pump Adjustment .....	20
Changing Materials .....	8	<b>Parts</b> .....	<b>21</b>
<b>Component Identification</b> .....	<b>9</b>	Hopper Parts List .....	22
Hopper Assembly .....	9	Xtreme-Duty Agitator Motor .....	23
<b>Setup</b> .....	<b>10</b>	Recommended Spare Parts .....	24
Initial System Setup .....	10	Accessories .....	24
Proper Lifting of Hopper .....	10	<b>Dimensions</b> .....	<b>25</b>
Grounding .....	11	Footprint and Bolt Pattern .....	25
<b>Installation</b> .....	<b>12</b>	<b>Technical Specifications</b> .....	<b>26</b>
Electrical Connections .....	12	<b>California Proposition 65</b> .....	<b>28</b>
Add Heating Fluid to Heated Hoppers .....	12	<b>Graco Standard Warranty</b> .....	<b>30</b>

## Related Manuals







Manual in English	Description
3A6283	XPs-hf™ Proportioner, Operation Manual
3A5312	Junction Box, Installation and Parts Manual
3A4032	Agitator Kits, Instructions and Parts Manual
313289	XM Proportioner, Operation Manual
307044	5:1 Monark Pump









## Component Approvals

Part	Description	Approvals
25N577	240V, 1 phase, Immersion Heater	  
25P234	480V, Immersion Heater	
25N584	Monark® 5:1 Ratio Feed Pump	  II 1/2 G Ex h IIB T2 Ga/Gb ETL23ATEX0276 ITS21UKEX0322
25N588	Xtreme-Duty™ Agitator	  II 1/2 G Ex h IIB T2 Ga/Gb ITS16ATEX100984X ITS21UKEX0262X 1°C < Ta < 40°C

# Safety Symbols

The following safety symbols appear throughout this manual and on warning labels. Read the table below to understand what each symbol means.

Symbol	Meaning
	Burn Hazard
	Crush Hazard
	Electric Shock Hazard
	Equipment Misuse Hazard
	Fire and Explosion Hazard
	Entanglement Hazard
	Moving Parts Hazard
	Skin Injection Hazard
	Skin Injection Hazard

Symbol	Meaning
	Splash Hazard
	Toxic Fluid or Fumes Hazard
	Ground Equipment
	Follow Pressure Relief Procedure
	Ventilate Work Area
	Wear Personal Protective Equipment
	Eliminate Ignition Sources
	Do Not Stop Leaks with Hand, Body, Glove or Rag
	Do Not Place Hands or Other Body Parts Near Fluid Outlet











**Safety Alert Symbol**









This symbol indicates: Attention! Become Alert! Look for this symbol throughout the manual to indicate important safety messages.

# Warnings

The following warnings apply throughout this manual. Read, understand, and follow the warnings before using this equipment. Failure to follow these warnings can result in serious injury.

 <h2 style="margin: 0;">DANGER</h2>	
 	<p><b>SEVERE ELECTRIC SHOCK HAZARD</b></p> <p>This equipment can be powered by more than 240 V. Contact with this voltage will cause death or serious injury.</p> <ul style="list-style-type: none"> <li>• Turn off and disconnect all power before disconnecting any cables and before servicing equipment.</li> <li>• This equipment must be grounded. Connect only to grounded power source.</li> <li>• All electrical wiring must be done by a qualified electrician and comply with all local codes and regulations.</li> <li>• Do not expose to rain. Store indoors.</li> </ul>

 <h2 style="margin: 0;">WARNING</h2>	
   	<p><b>FIRE AND EXPLOSION HAZARD</b></p> <p>Flammable fumes, such as solvent and paint fumes, in work area can ignite or explode. Paint or solvent flowing through the equipment can cause static sparking. To help prevent fire and explosion:</p> <ul style="list-style-type: none"> <li>• Use equipment only in well ventilated area.</li> <li>• Eliminate all ignition sources; such as pilot lights, cigarettes, portable electric lamps, and plastic drop cloths (potential static sparking).</li> <li>• Ground all equipment in the work area. See <b>Grounding</b> instructions.</li> <li>• Never spray or flush solvent at high pressure.</li> <li>• Keep work area free of debris, including solvent, rags and gasoline.</li> <li>• Do not plug or unplug power cords, or turn power or light switches on or off when flammable fumes are present.</li> <li>• Use only grounded hoses.</li> <li>• Hold gun firmly to side of grounded pail when triggering into pail. Do not use pail liners unless they are anti-static or conductive.</li> <li>• <b>Stop operation immediately</b> if static sparking occurs or you feel a shock. Do not use equipment until you identify and correct the problem.</li> <li>• Keep a working fire extinguisher in the work area.</li> </ul>

 <h1 style="margin: 0;">WARNING</h1>	
 	<p><b>ENTANGLEMENT HAZARD</b></p> <p>Rotating parts can cause serious injury.</p> <ul style="list-style-type: none"> <li>• Keep clear of moving parts.</li> <li>• Do not operate equipment with protective guards or covers removed.</li> <li>• Do not wear loose clothing, jewelry or long hair while operating equipment.</li> <li>• Equipment can start without warning. Before checking, moving, or servicing equipment, follow the <b>Pressure Relief Procedure</b> and disconnect all power sources.</li> </ul>
 	<p><b>MOVING PARTS HAZARD</b></p> <p>Moving parts can pinch, cut or amputate fingers and other body parts.</p> <ul style="list-style-type: none"> <li>• Keep clear of moving parts.</li> <li>• Do not operate equipment with protective guards or covers removed.</li> <li>• Equipment can start without warning. Before checking, moving, or servicing equipment, follow the <b>Pressure Relief Procedure</b> and disconnect all power sources.</li> </ul>
 	<p><b>EQUIPMENT MISUSE HAZARD</b></p> <p>Misuse can cause death or serious injury.</p> <ul style="list-style-type: none"> <li>• Do not operate the unit when fatigued or under the influence of drugs or alcohol.</li> <li>• Do not exceed the maximum working pressure or temperature rating of the lowest rated system component. See <b>Technical Specifications</b> in all equipment manuals.</li> <li>• Use fluids and solvents that are compatible with equipment wetted parts. See <b>Technical Specifications</b> in all equipment manuals. Read fluid and solvent manufacturer's warnings. For complete information about your material, request Safety Data Sheets (SDS) from distributor or retailer.</li> <li>• Do not leave the work area while equipment is energized or under pressure.</li> <li>• Turn off all equipment and follow the <b>Pressure Relief Procedure</b> when equipment is not in use.</li> <li>• Check equipment daily. Repair or replace worn or damaged parts immediately with genuine manufacturer's replacement parts only.</li> <li>• Do not alter or modify equipment. Alterations or modifications may void agency approvals and create safety hazards.</li> <li>• Make sure all equipment is rated and approved for the environment in which you are using it.</li> <li>• Use equipment only for its intended purpose. Call your distributor for information.</li> <li>• Route hoses and cables away from traffic areas, sharp edges, moving parts, and hot surfaces.</li> <li>• Do not kink or over bend hoses or use hoses to pull equipment.</li> <li>• Keep children and animals away from work area.</li> <li>• Comply with all applicable safety regulations.</li> </ul>
	<p><b>BURN HAZARD</b></p> <p>Equipment surfaces and fluid that is heated can become very hot during operation. To avoid severe burns:</p> <ul style="list-style-type: none"> <li>• Do not touch hot fluid or equipment.</li> </ul>



# WARNING



## TOXIC FLUID OR FUMES HAZARD

Toxic fluids or fumes can cause serious injury or death if splashed in the eyes or on skin, inhaled or swallowed.

- Read Safety Data Sheets (SDSs) for handling instructions and to know the specific hazards of the fluids you are using, including the effects of long-term exposure.
- When spraying, servicing equipment, or when in the work area, always keep work area well-ventilated and always wear appropriate personal protective equipment. See **Personal Protective Equipment** warnings in this manual.
- Store hazardous fluid in approved containers, and dispose of it according to applicable guidelines.



## PERSONAL PROTECTIVE EQUIPMENT

Always wear appropriate personal protective equipment and cover all skin when spraying, servicing equipment, or when in the work area. Protective equipment helps prevent serious injury, including long-term exposure; inhalation of toxic fumes, mists or vapors; allergic reaction; burns; eye injury and hearing loss. This protective equipment includes but is not limited to:

- A properly fitting respirator, which may include a supplied-air respirator, chemically impermeable gloves, protective clothing and foot coverings as recommended by the fluid manufacturer and local regulatory authority.
- Protective eyewear and hearing protection.

# Important Isocyanate (ISO) Information

Isocyanates (ISO) are catalysts used in two component materials.

## Isocyanate Conditions



Spraying or dispensing fluids that contain isocyanates creates potentially harmful mists, vapors, and atomized particulates.

- Read and understand the fluid manufacturer's warnings and Safety Data Sheets (SDSs) to know specific hazards and precautions related to isocyanates.
- Use an isocyanates involves potentially hazardous procedures. Do not spray with this equipment unless you are trained, qualified, and have read and understood the information in this manual and in the fluid manufacturer's application instructions and SDSs.
- Use of incorrectly maintained or mis-adjusted equipment may result in improperly cured material. Equipment must be carefully maintained and adjusted according to instructions in the manual.
- To prevent inhalation of isocyanates mists, vapors, and atomized particulates, everyone in the work area must wear appropriate respiratory protection. Always wear a properly fitting respirator, which may include a supplied-air respirator. Ventilate the work area according to instructions in the fluid manufacturer's SDSs.
- Avoid all skin contact with isocyanates. Everyone in the work area must wear chemically impermeable gloves, protective clothing and foot coverings as recommended by the fluid manufacturer and local regulatory authority. Follow all fluid manufacturer recommendations, including those regarding handling of contaminated clothing. After spraying, wash hands and face before eating or drinking.

## Keep Components A and B Separate



Cross-contamination can result in cured material in fluid lines which could cause serious injury or damage equipment. To prevent cross-contamination.

- **Never** interchange component A and component B wetted parts.
- Never use solvent on one side if it has been contaminated from the other side.

## Moisture Sensitivity of Isocyanates

Exposure to moisture (such as humidity) will cause ISO to partially cure, forming small, hard, abrasive crystal that become suspended in the fluid. Eventually a film will form on the surfaces and the ISO will begin to gel, increasing in viscosity.

### NOTICE

Partially cured ISO will reduce performance and the life of all wetted parts.

- Always use a sealed container with a desiccant dryer in the vent, or a nitrogen atmosphere. **Never** store ISO in an open container.
- Keep the ISO pump wet cup or reservoir (if installed) filled with appropriate lubricant. The lubricant creates a barrier between the ISO and the atmosphere.
- Use only moisture-proof hoses compatible with ISO.
- Never use reclaimed solvents, which may contain moisture. Always keep solvent containers closed when not in use.
- Always lubricate threaded parts with an appropriate lubricant when reassembling.

**NOTE:** The amount of film formation and rate of crystallization varies depending on the blend of ISO, the humidity, and the temperature.

## Changing Materials

### NOTICE

Changing the material types used in your equipment requires special attention to avoid equipment damage and downtime.

- When changing materials, flush the equipment multiple times to ensure it is thoroughly clean.
- Always clean the fluid inlet strainers after flushing.
- Check with your material manufacturer for chemical compatibility.
- When changing between epoxies and urethanes or polyureas, disassemble and clean all fluid components and change hoses. Epoxies often have amines on the B (hardener) side. Polyureas often have amines on the B (resin) side.

# Component Identification

## Hopper Assembly

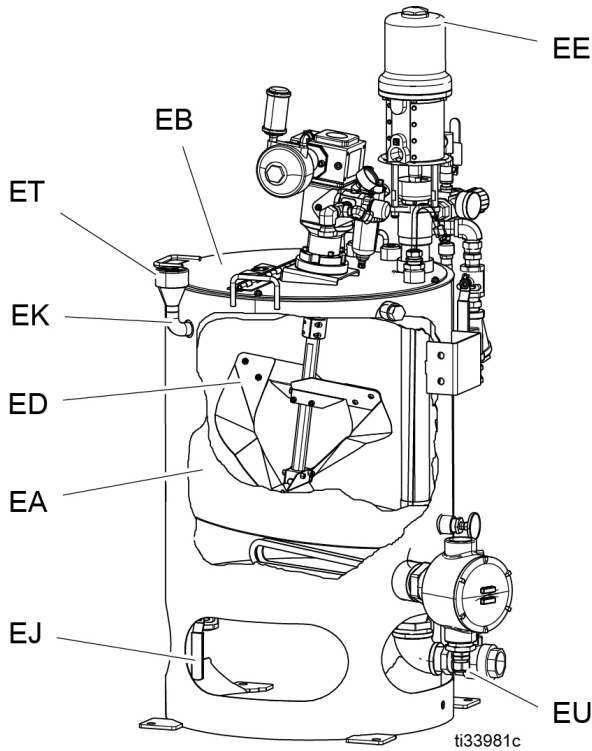

**Non-Hazardous Locations**

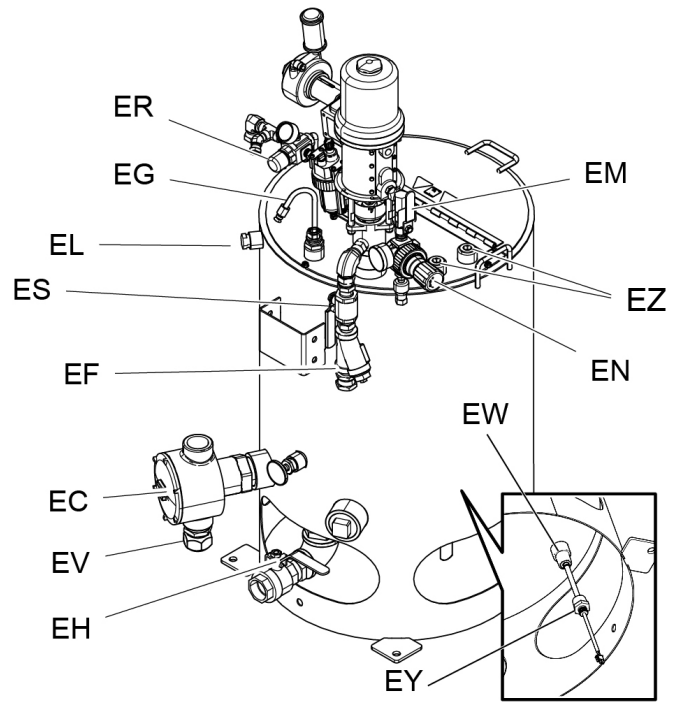

**Hazardous Locations**

**Ref. Description**

- EA Double Wall Hopper
- EB Hopper Lid
- EC Immersion Heater
- ED Agitator
- EE Feed Pump
- EF Y-Strainer
- EG Recirculation Line
- EH Material Drain
- EJ Heating Fluid Drain Valve
- EK Heating Fluid Fill Port
- EL Vent
- EM Air Valve (Feed Pump)
- EN Air Regulator (Feed Pump)

**Ref. Description**

- EP Air Valve (Agitator)
- ER Air Regulator (Agitator)
- ES Y-Strainer Valve
- ET Fill Port Cap
- EU Cord Grip
- EV Adapter
- EW Float Switch
- EY Cable Adapter
- EW\* Float Switch
- EY\* Cable Adapter
- EZ Plugs
- \* Required for Hazardous Location Installation

# Setup

## Initial System Setup

1. Check the shipment for accuracy. Ensure you have received everything you ordered. See **Component Identification**, page 9.
2. Check for loose fittings and fasteners.
3. Confirm air supply requirements.
4. Confirm electric power requirements and make sure a properly sized electrical cord is used.

**NOTE:** A minimum of 12 gallons (45 L) of heating fluid is needed per hopper.

**NOTE:** A minimum of 10 gallons (38 L) of “A” and “B” materials are needed to load and prime each hopper.

**NOTE:** A minimum of 25 gallons (95 L) of solvent is required for flushing.

**NOTE:** Empty metal pails for both “A” and “B” materials are required for flushing.

## Location

1. Locate the hopper on a level surface. Follow the **Proper Lifting of Hopper** procedure.
2. Position the hopper for convenient operator access and maintenance, proper routing of air and fluid lines, and easy connection of components and accessories.

## Proper Lifting of Hopper



Follow these instructions to help prevent serious injury or damage to equipment. Never lift while a hopper is filled.

### NOTICE

To prevent spilling and to ensure even weight distribution, drain all fluid prior to lifting the hopper.

## Lift Using a Forklift

When mounted on skid (see **Accessories**, page 24) the hopper can be raised and moved using a forklift. Disconnect power and air from the unit. Carefully lift the hopper; make sure it balances evenly.

## Lift Using a Hoist

- Lift the hopper with a lift apparatus rated appropriately for the weight of the system (see **Technical Specifications**, page 26).
- Lift the hopper using the handles as shown in the illustration.

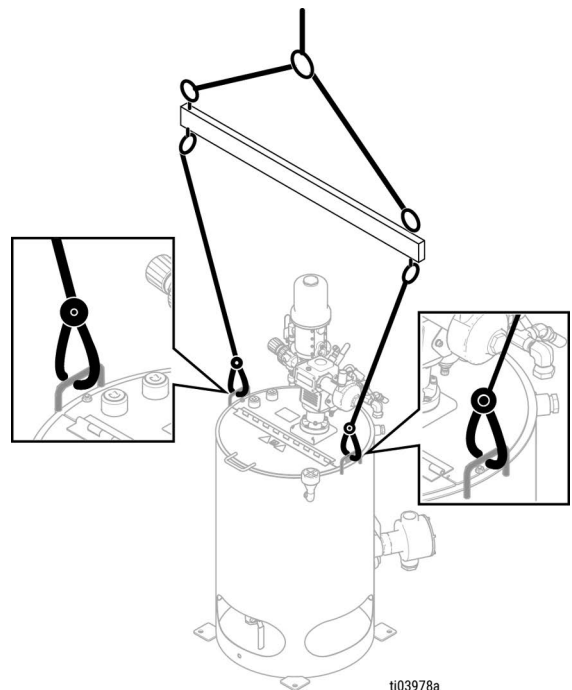

ti03978a

## Grounding



The equipment must be grounded to reduce the risk of static sparking and electric shock. Electric or static sparking can cause fumes to ignite or explode. Improper grounding can cause electric shock. Grounding provides an escape wire for the electric current.

**Heater:** Connect the supply ground wire in the heater head.

**Air and fluid hoses:** Use only electrically conductive hoses with a maximum of 300 ft (91 m) combined hose length to ensure grounding continuity. Check electrical resistance of hoses regularly. If total resistance to ground exceeds 29 megaohms, replace hose immediately.

**Solvent pails:** Follow your local code. Use only metal pails, which are conductive, placed on a grounded surface. Do not place pail on a non-conductive surface, such as paper or cardboard, which interrupts grounding continuity.

**To maintain grounding continuity when flushing or relieving pressure:** Hold the circulation tube firmly to the side of a grounded metal pail.

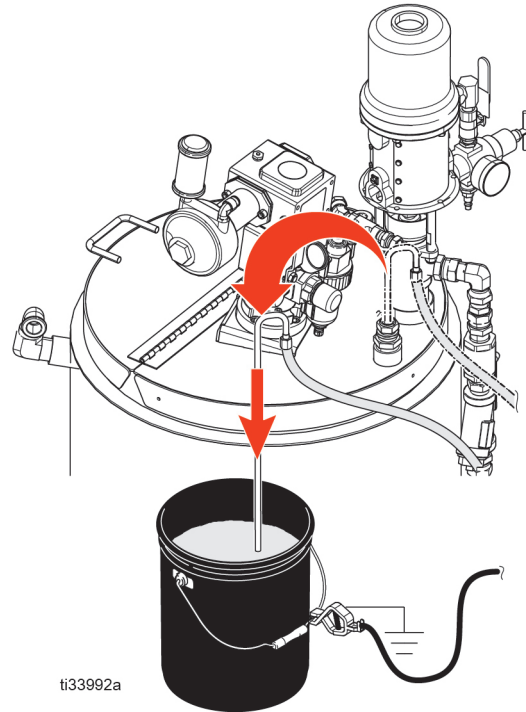

**Work area:** Ground the object being sprayed, fluid supply container, and all other equipment in the work area.

**Air compressor:** Follow manufacturer's recommendations.

**Object being sprayed:** Follow your local code.

**Material supply container:** Follow your local code.

# Installation

<p>To prevent injury from fire or explosion due to an exposed heating element:</p> <ul style="list-style-type: none"> <li>• Install an overtemperature or liquid level sensor in each 25 gallon hopper.</li> <li>• Do not allow the heating fluid level to drop below the heating element.</li> </ul>				

<p>If your sprayer is intended for hazardous locations, a qualified electrician must connect the explosion-proof heater wiring. Ensure wiring and installation comply with local codes and regulations for hazardous locations.</p>				

## Electrical Connections

<p>Improper wiring may cause electric shock or other serious injury if work is not performed properly.</p> <ul style="list-style-type: none"> <li>• This equipment must be grounded. Connect only to a grounded power source.</li> <li>• All electrical wiring must be done by a qualified electrician and comply with all local codes and regulations.</li> </ul>				

<b>NOTICE</b>				
<p>To help prevent damage, avoid spilling liquids onto electrical components and never operate with the cover removed or screws missing.</p>				

## Installation Requirements

- The heater requires a dedicated circuit protected with a circuit breaker.
- Power conductors used for supply connection must be 10 AWG or larger and suitable for at least 221°F (105°C).
- For Non-Hazardous Location, the power cord must pass through the strain relief cord grip (87). It will accept cords with an outside diameter of 0.51-0.71 in. (13-18 mm).

- Make ground connection to the green ground screw inside the heater head.
- Make power connections to the two post bushings in the heater head. Refer to the applicable schematic on page 19.
- Install an overtemperature or liquid level sensor in each heated hopper when used in hazardous locations. Float Switch Kit 2009901 is sold separately.

## Add Heating Fluid to Heated Hoppers

<p>To prevent injury from fire or explosion due to an exposed heating element:</p> <ul style="list-style-type: none"> <li>• Install an overtemperature or liquid level sensor in each heated hopper.</li> <li>• Do not allow the heating fluid level to drop below the heating element.</li> </ul>				

1. Use a 50/50 mixture of water and ethylene glycol (engine coolant) for heating fluid in the outer cavity of the hopper. Approximately 12 gallons (45 liters) of heating fluid is needed for each hopper.

<b>NOTICE</b>	
<p>Other glycols (RV/Marine Antifreeze) are not recommended for use as a heating fluid. These materials are not rated for higher temperatures and could cause damage to the immersion heaters.</p>	

- Remove fill port cap (ET) and pour heating fluid in the outer cavity through the fill port (EK).

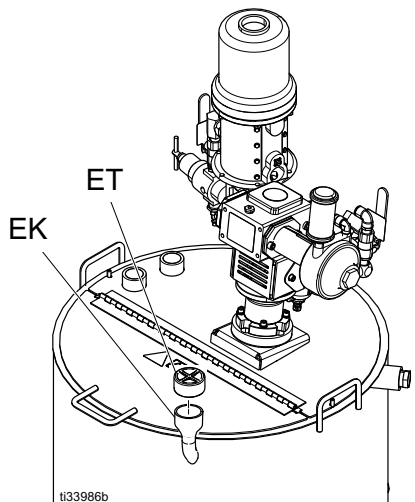

- Use approximately 12 gallons (53 liters) to fill the cavity. Stop filling when fluid is visible at the bottom of the port elbow.

**NOTE:** Thermal expansion may cause the heating fluid to overflow after it rises to temperature.

- Replace the fill port cap (ET).

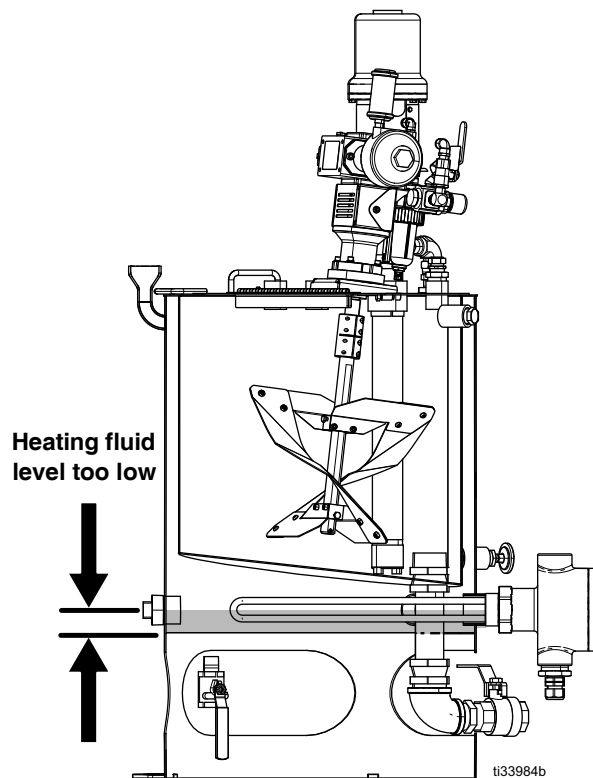

**NOTICE**

Any portion of the heating element exposed to air will lead to overheating and premature burnout. Ensure that the element is completely submerged in heating fluid.

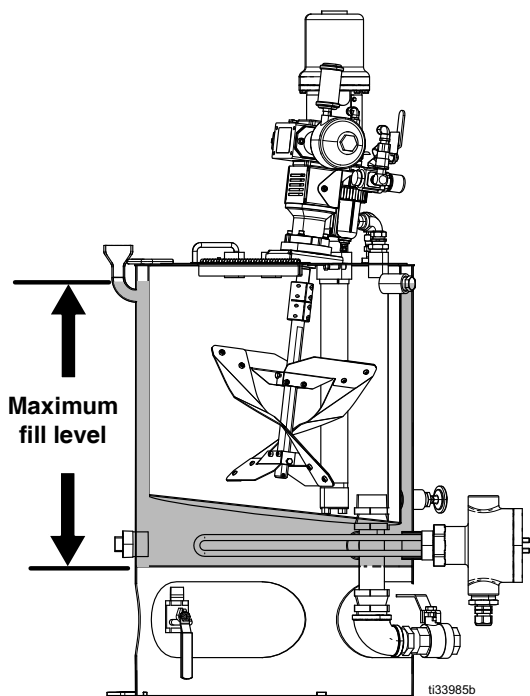

## Agitators (ED)

The Xtreme-Duty Agitator is provided with an airline lubricator to aid in proper maintenance. Fill the lubricator with Air Motor Oil 202659 (do not fill past the maximum level shown in the oil fill sight glass). Set the lubricator feed rate at one drop of oil per minute. Do not overfeed the oil, or the exhaust air may become contaminated.

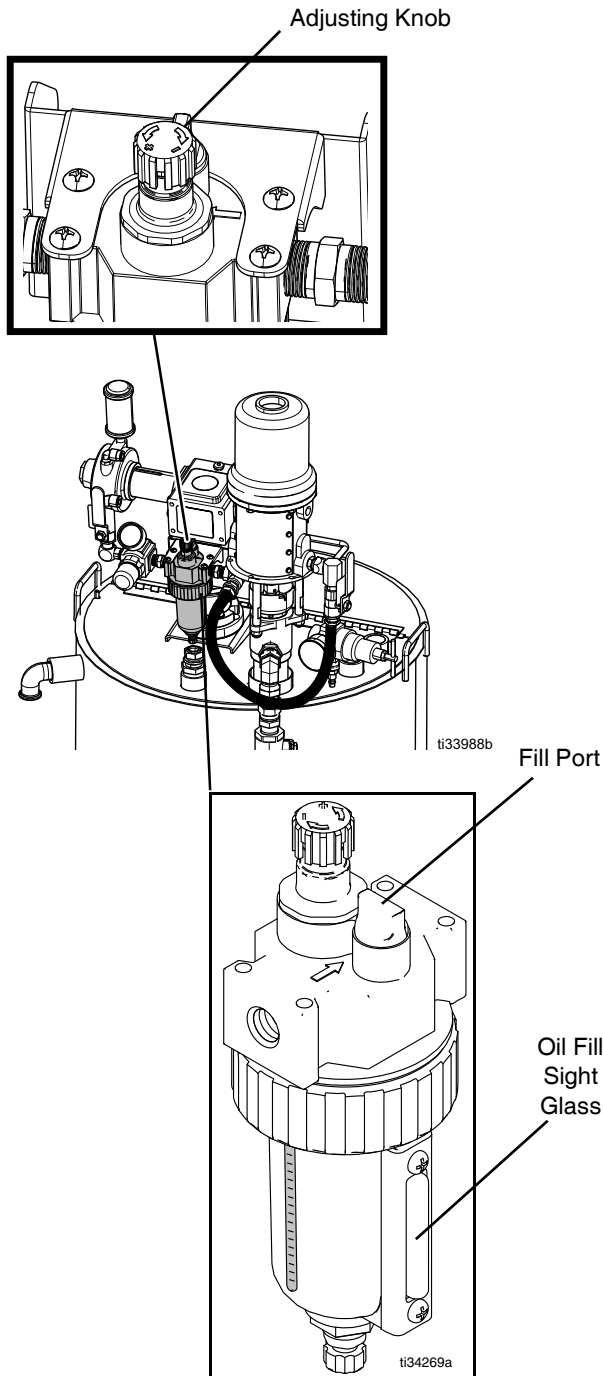

## Feed Pumps (EE)

Fill the wet-cup half full with Graco Throat Seal (TSL™) or a compatible solvent.

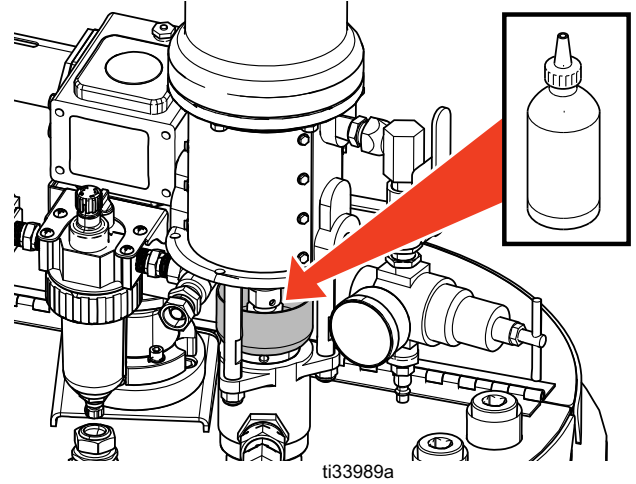

# Troubleshooting

Follow the **Pressure Relief Procedure** in your sprayer manuals before servicing this equipment.

Check all possible problems and solutions before disassembling the hopper components.

Problem	Cause	Solution
The feed pump fails to operate.	The air line is restricted or there is inadequate air supply.	Clear the line, or increase the air supply.
	Insufficient air pressure; closed or clogged air valves, etc.	Open air valve, clean if necessary.
	The fluid supply has been exhausted.	Refill the fluid supply. Purge all air from the pump and fluid lines.
	The air motor has been damaged.	Service the air motor (see your air motor manual).
	The strainer valve is closed.	Open the strainer valve.
The feed pump operates, but the output is low on both strokes.	The air line is restricted or there is inadequate air supply.	Clear the line, or increase the air supply.
	The air pressure is insufficient, or the air valves are clogged or closed.	Open the air valve and clean it if necessary.
	The fluid supply has been exhausted.	Refill the fluid supply. Purge all air from the pump and fluid lines.
	The fluid line, valves, and/or Y-strainer are clogged.	Clear the fluid line, valves, and/or y-strainer.
	The fluid check valves need to be adjusted.	Check the fluid check valves and adjust if needed.
	The packing nut is loose.	Tighten the packing nut.
	The throat packings are worn.	Replace worn throat packings.
	The cylinder o-rings are damaged.	Replace the cylinder o-rings.
The feed pump operates, but the output is low on the down stroke.	The intake valve is worn or held open.	Clear and service the intake valve.
	The cylinder o-rings are damaged.	Replace the cylinder o-rings.
The feed pump operates, but the output is low on the up stroke.	The intake valve is worn or held open.	Clear and service the intake valve.
The feed pump operates but is erratic or accelerated.	The fluid supply has been exhausted.	Refill the fluid supply. Purge all air from the pump and fluid lines.
	The fluid check valves need to be adjusted.	Check the fluid check valves and adjust if needed.
	The intake valve is worn or held open.	Clear and service the intake valve.
	The fluid piston valve is worn or held open.	Clear and service the fluid piston valve.

Problem	Cause	Solution
There is algae buildup in the outer cavity of the hopper.	Ethylene glycol was not added to the water.	Drain the fluid. Add 50/50 water and ethylene glycol mixture in the outer cavity.
The immersion heater is no longer heating.	The immersion heater over-temperature switch was tripped.	Remove the heater cover and press the reset (red button).
	The circuit breaker is tripped.	Open the junction box and reset the circuit breaker. See your junction box manual.
Heating fluid is leaking into the spray material in side the hopper.	The inside wall of the hopper is damaged.	Replace the hopper.
The hopper is not heating all the way to the top.	The heating fluid level is low.	Refill the heating fluid.
There is oil residue on the hopper lid and/or agitator muffler.	The oil lubricator is over-feeding and exhaust air is saturated with oil.	Set the lubricator feed rate lower and adjust as needed.
The agitator air motor operation is sluggish.	The air motor is not properly lubricated.	Flush the air motor (see your air motor manual). Add oil to the lubricator.
The agitator motor is running but the shaft is not spinning.	The agitator blades are not secured against the flats.	Remove the coupler shaft and inspect. See <b>Installing the Agitator Blade in the Hopper</b> , page 18.
	The coupler is not torqued tightly enough.	Check the torque of the four screws in the coupler.
The hopper takes too long to heat up.	The hoppers maintain temperature after material has been circulated and heated with the HF heaters.	Agitate and circulate material in hoppers.
The hopper temperature is not warm enough.	The hopper is factory set--do not adjust. All heating needs to be done through the HF heaters.	Use the HF heaters to agitate and circulate material inside the hoppers.

# Repair

## Immersion Heater

### Removal

1. Follow **Pressure Relief Procedure** in your sprayer manual before servicing this equipment.
2. FOR ORDINARY LOCATION UNITS: Open the valve (7) to drain heating fluid from the hopper outer cavity.
3. FOR HAZARDOUS LOCATION UNITS: Remove the Float Switch (EW) to drain the heating fluid.
4. Rotate the heater cover (HC) counterclockwise and remove it from the immersion heater (2).
5. Disconnect the wire nuts and wire connections inside the immersion heater head and remove cable. See the wiring diagram in your junction box manual.

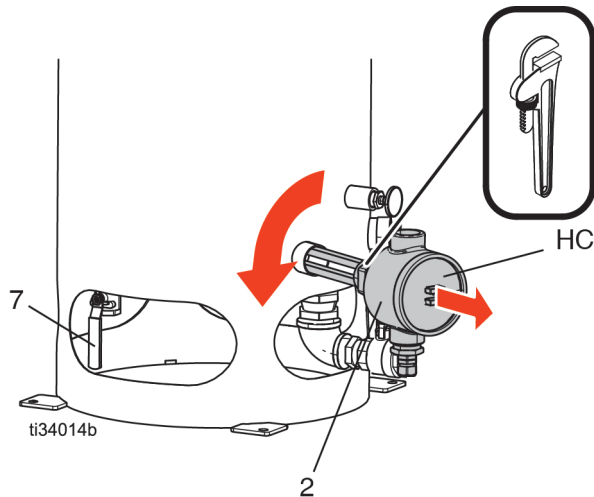

6. Slowly unscrew the immersion heater (2) from the hopper.

### NOTICE

Bent heating elements may cause over heating and hot spots along the tank wall and/or early failure. Do not bend the heating elements during removal or installation.

7. Inspect the heater element coils for excessive corrosion. If necessary, replace the entire immersion heater.

## Agitator

### Agitator Motor Removal

1. Follow **Pressure Relief Procedure** in your sprayer manual before servicing this equipment.
2. Loosen all four screws on the coupler (16d) and slide it down the blade shaft (16e).

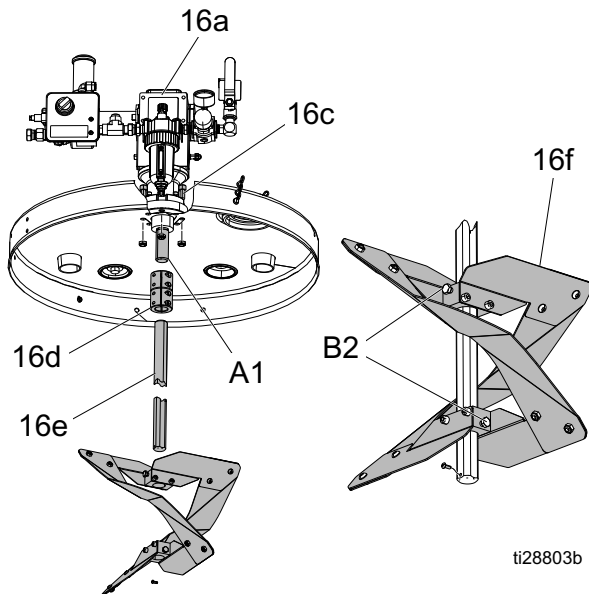

3. Unscrew four bolts (16c) of the agitator motor (16a).
4. Lift the agitator motor (16a) off of the hopper.
5. See your agitator manual for motor repair information.

### Agitator Blade Removal

1. Follow **Pressure Relief Procedure** in your sprayer manual before servicing this equipment.
2. Loosen the four screws on coupler (16d) and slide it down the blade shaft (16e).
3. Loosen two screws (B2) and slide the blade assembly off of shaft (16e).
4. Maneuver the agitator blade assembly out of the hopper opening.

### Installing the Agitator Blade in the Hopper

1. Follow **Pressure Relief Procedure** in your sprayer manual before servicing this equipment.
2. Slide the agitator blade (16f) onto the shaft (16e). Position the agitator blade coupling screws (B2) so they contact the flats of the shaft (16f).
3. Hand tighten screws (B2).
4. Slide coupler (16d) fully onto the shaft (16e).
5. Maneuver the blade assembly into the hopper and align the shaft (16e) with the output shaft of the agitator drive (A1).
6. Slide the coupler (16d) onto the output shaft (A1) up to the mid-point of the coupler.
7. Tighten the four screws evenly, then torque to 15 ft-lb (20 N•m).

### Adjusting the Agitator Blade

1. Follow **Pressure Relief Procedure** in your sprayer manual before servicing this equipment.
2. Loosen two screws (B2).
3. Slide the agitator blade (16f) to the desired height and tightened the two screws evenly on each flat.
4. Torque screws (B2) to 13 ft-lb (17.6 N•m).

# Feed Pump

## Removal

1. Follow **Pressure Relief Procedure** in your sprayer manual before servicing this equipment.
2. Disconnect the Y-strainer (23).
3. Disconnect the air controls (24).
4. Loosen the screw on the bung adapter (233).
5. Unscrew the bung adapter (233) from the hopper lid (25).
6. Pull the feed pump straight up and out of the hopper.

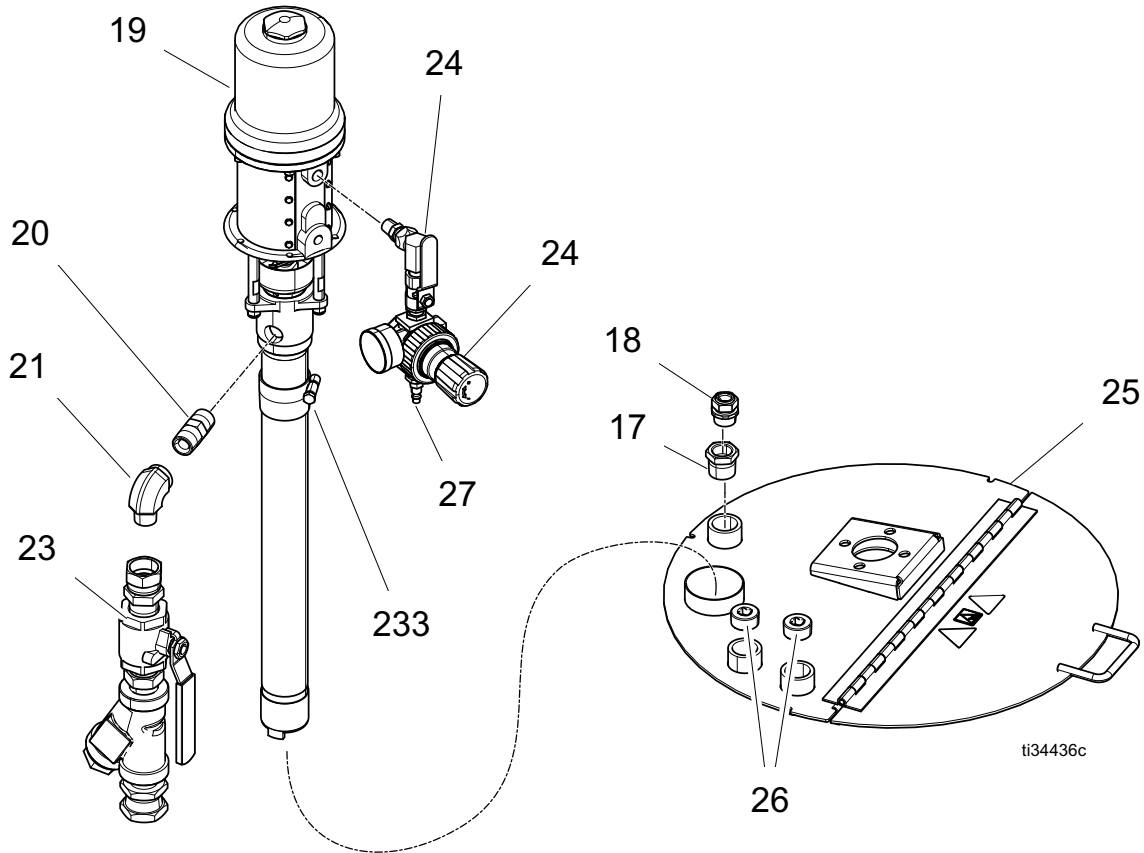

## Feed Pump Adjustment

The piston and intake check valves are set for medium viscosity fluids. To adjust the valves:

1. See **Troubleshooting** on page 15 before servicing this equipment.
2. Follow Pressure Relief Procedure in your sprayer manual before servicing this equipment.
3. Disassemble the Feed Pump, see your feed manual.
4. Remove the ball pin (217) from the intake valve seat (230). Move the pin to a higher set of holes to increase the ball travel for heavier fluids, or to a lower set of holes to decrease the ball travel for lighter fluids.
5. To adjust the piston ball travel, loosen the locknut (203) and turn the piston (211) counterclockwise to increase the ball travel and clockwise to decrease the ball travel. For medium viscosity fluids, the ball travel should be 0.19 in. (4.8 mm).

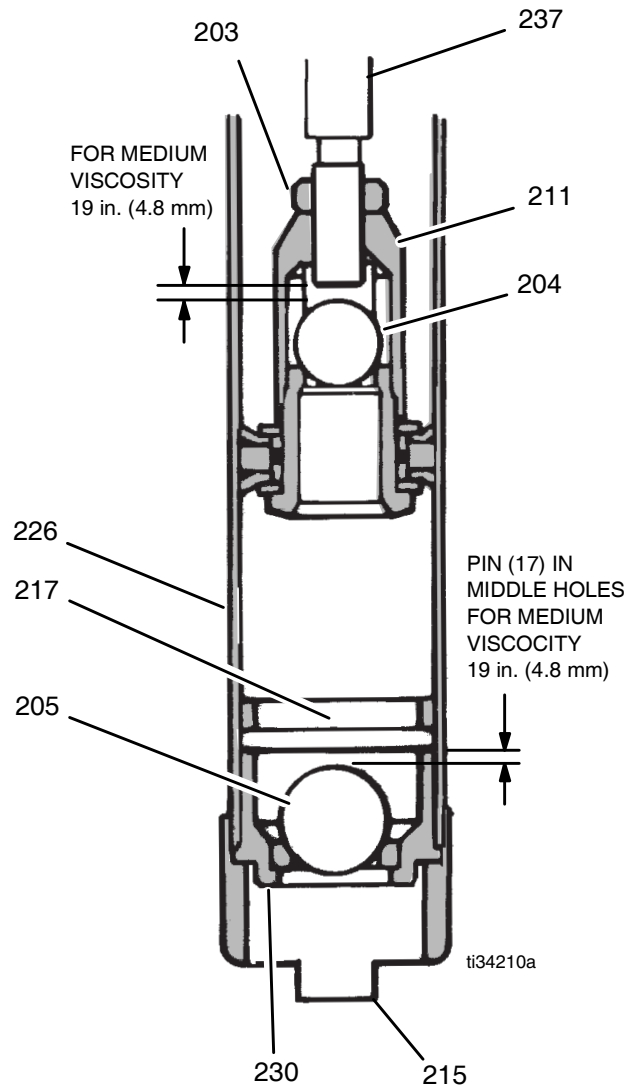

# Parts

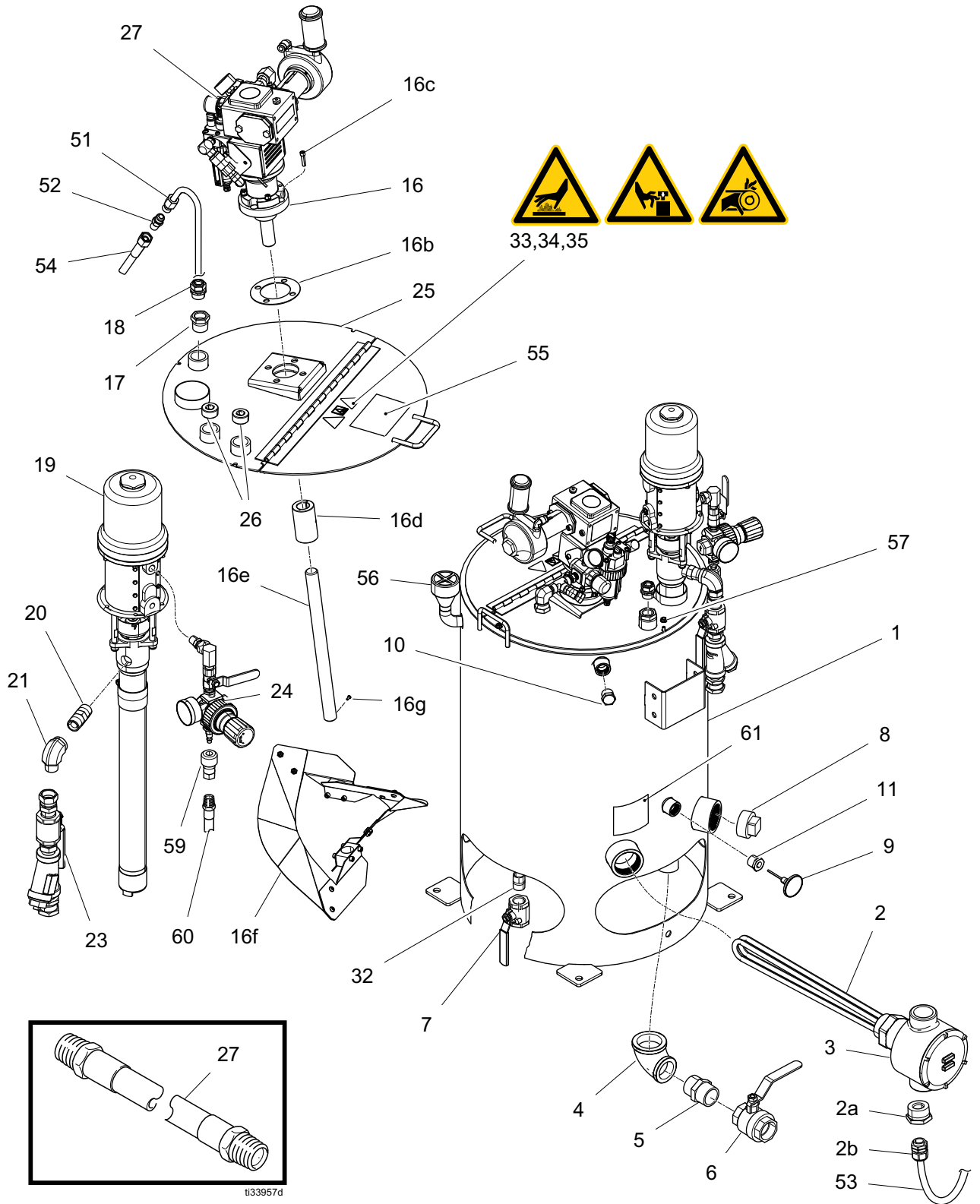

## Hopper Parts List

### Model 26C482

Ref.	Part	Description	Qty.	Ref.	Part	Description	Qty.
1	25N582	HOPPER, XPs, bare hopper	1	18	129347	BUSHING, strain relief, 3/4 npt	1
2	25N577	HEATER, immersion, 240V (model 24C482)	1	19	25N584	PUMP, Monark, 5-1, hopper	1
	25P239	HEATER, immersion, 480V (model 26B279)		20	175013	FITTING, nipple, pipe	1
2a	101496	BUSHING, pipe	1	21	122327	FITTING, elbow, street	1
2b	121603	GRIP CORD (non-haz models)	1	23	256653	KIT, fluid inlet	1
	185065	ADAPTER (haz loc models)		24	248829	KIT, regulator, air, feed pump	1
4	120291	PIPE, elbow female	1	25	25N581	LID, XPs hopper lid	1
5	121441	FITTING, nipple, hex, 1 1/2npt	1	26	121497	PLUG, pipe headless	2
6	121440	VALVE, ball, 1 1/2 npt	1	27	217382	HOSE, coupled 61089	1
7	109077	VALVE, ball (non-haz models)	1	32	100350	FITTING, nipple 3/4 npt (non haz models)	1
	2010085	CABLE, extension (haz loc models)			2009898	SWITCH, float (haz loc models)	
8	123807	PLUG, pipe, 2 in.	1	33▲	189285	LABEL, safety, burn	1
9	102124	THERMOMETER, dial	1	34▲	15W349	LABEL, caution, pinch point	1
10	111530	MUFFLER, vent	1	35▲	16M768	LABEL, safety, warning, entangle	1
11	100615	BUSHING, hex steel	1	51	17V987	TUBE, recirculation	1
16	25N588	XTREME-duty, agitator, hopper	1	52	116704	ADAPTER, 9/16-18 jic x 1/4 npt	1
16a	-----	AGITATOR MOTOR (see page 23 for details)	1	54	H52510	HOSE, cpld, 5600 psi, .25 ID, 10 ft	
16b	24P837	GASKET, agitator	1	55	2009898	SWITCH, float (haz units)	1
16c	109212	SCREW, cap, sch	4	56	17Y308	CAP, hopper	1
16d	16T245	COUPLING, shaft, one piece clamp	1	57	115942	NUT, hex, flanged head	3
16e	17X392	SHAFT, agitator	1	58	2010085	CABLE, extension (haz units)	1
16f	17J004	BLADE, assembly, XD agitator	1	59	110198	COUPLER	1
16g	16C795	SCREW, sst, button socket head	1	60	109130	HOSE, coupled 48 in.	1
17	158586	FITTING, bushing	1	61	15W776	LABEL, warning	1

▲ Replacement safety labels, tags, and cards are available at no cost.

# Xtreme-Duty Agitator Motor

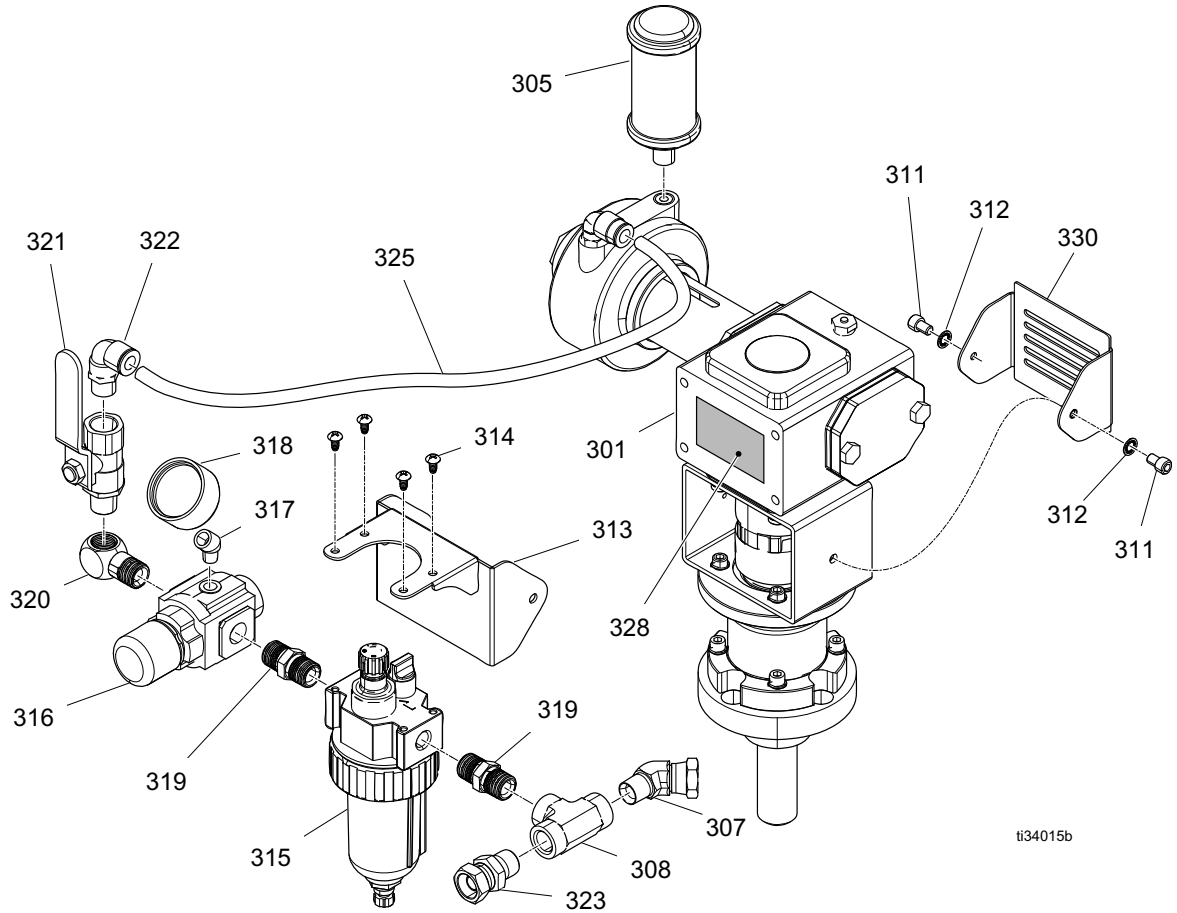

## Parts List

Ref.	Part	Description	Qty.	Ref.	Part	Description	Qty.
301	-----	AGITATOR, drive train*	1	318	113911	GAUGE, pressure, air	1
305	129069	MUFFLER, air, exhaust	1	319	156849	PIPE, nipple	2
307	17X390	FITING, 45°, 3/8-18 npt m x 3/8-18 f	1	320	155699	FITTING, elbow, street	1
308	114526	FITTING, tee, pipe	1	321	113333	VALVE, ball, vented, 0.375	1
311	C19798	SCREW, cap, socket head	2	322	16F151	FITTING, elbow, swivel, 3/8 t 3/8 npt	1
312	100028	WASHER, lock	2	323	155665	UNION, adapter	1
313	17L435	BRACKET, mounting, air lubricator	1	325	C12508	TUBING, nylon, round	1
314	128277	SCREW, self-tap, 10-24 x 3/8	4	328	17E348	LABEL, Xtreme-duty agitator	1
315	214847	LUBRICATOR, air line	1	330	17M563	BRACKET, guard, coupling	1
316	15T539	REGULATOR, air, 3/8 npt	1				
317	113630	ELBOW, street 45° 1/8 npt	1				

\* See Xtreme-Duty Agitator and Packages manual for part details.

## Recommended Spare Parts

### Pump

Part	Description
100103	PIN, cotter
100279	BALL, metallic
101178	BALL, metallic
156082	PACKING, o-ring
204762	INTAKE VALVE, seat
25N586	REPAIR Kit

### Y-Strainer

Part	Description
26A350	KIT, filter replacement (10 pack)
187758	GASKET, flat, PTFE

### Agitator

Part	Description
202659	Motor Lubricant
15T539	Air Regulator

## Accessories

26C549	Hopper Stand
262820	Flexible Fluid Connection Kit

# Dimensions

## Footprint and Bolt Pattern

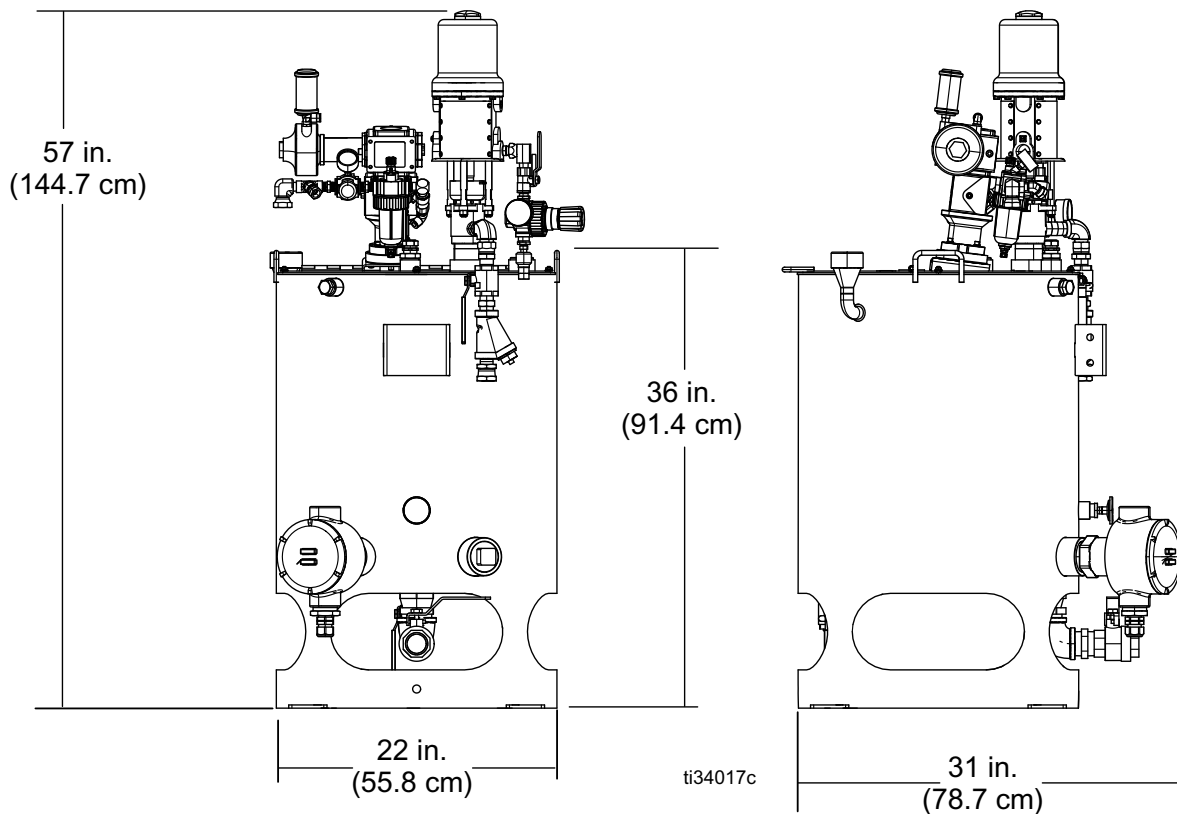
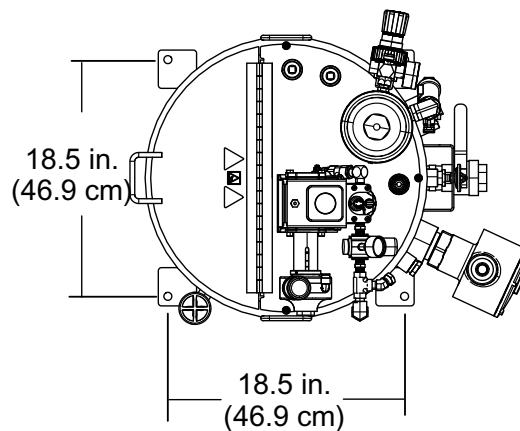

# Technical Specifications

<b>Double-Wall Hopper</b>		
	<b>US</b>	<b>Metric</b>
Maximum Air Inlet Pressure	100 psi	0.7 MPa, 7 Bar
Ambient Operating Temperature	32-122 °F	0-50 °C
Temperature (set point)	110 °F	43 °C
Spray Material Capacity	25 gallon	94.6 liters
Heating Fluid Capacity	12 gallon	45.4 liters
Power Input (if not using a junction box)	230 VAC, 1 Phase, 50/60 Hz, 15 A	
Wetted Parts	Stainless steel, brass, nickel plating, PTFE	

<b>Feed Pump</b>		
	<b>US</b>	<b>Metric</b>
Pump Cycles	28 cycles per gallon	28 cycles per 3.8 liters
Maximum Recommended Pump Speed (66 cycles per minute)	2.5 gallons per minute	9.5 liters per minute
Recommended Speed for Optimum Pump Life (12-25 cycles per minute)	0.5-0.9 gallons per minute	1.9-3.3 liters per minute
Air Consumption per 1 gpm (3.78 lpm) of flow	Approximately 8 scfm at 100 psi air pressure	Approximately 226 liters per minute at 0.7 MPa, 7 Bar air pressure
Maximum Fluid Working Pressure	500 psi	3.44 MPa, 34 bar
Maximum Air Input	100 psi	0.69 MPa, 6.9 bar
Maximum Pump Operating Temperature	250 °F	121 °C
Maximum Air Motor Operating Temperature	200 °F	90 °C
Wetted Parts	Plated carbon steel, stainless steel, PTFE	

<b>Xtreme Duty Agitator</b>		
	<b>US</b>	<b>Metric</b>
Maximum Recommended Shaft Speed	60 rpm	
Air Consumption at 60 rpm	11 cfm @ 20 psi 30 cfm @ 80 psi	5.2 L/s @ 1.4 bar 14 L/s @ 5.5 bar
Stall Torque at Maximum Air inlet Pressure	1120 in-lb	127 N•m
Weight	50 lb	22.6 kg
Air Inlet Size	3/8 in. nps(f)	
Maximum Air Inlet	100 psi	0.7 MPa, 7 bar
Ambient Temperature Range	32-122 °F	0-50 °C
Wetted Parts	Stainless steel	
Noise Level	See your agitator motor manual.	
<b>Notes</b>		
<p>* Tested at a distance of 1 meter (3.2 ft) from equipment.                      ** Tested per ISO 9614-Z</p> <p>All trademarks or registered trademarks are the property of their respective owners.</p>		

# California Proposition 65

## CALIFORNIA RESIDENTS

 **WARNING:** Cancer and reproductive harm – [www.P65warnings.ca.gov](http://www.P65warnings.ca.gov).



# Graco Standard Warranty

Graco warrants all equipment referenced in this document which is manufactured by Graco and bearing its name to be free from defects in material and workmanship on the date of sale to the original purchaser for use. With the exception of any special, extended, or limited warranty published by Graco, Graco will, for a period of twelve months from the date of sale, repair or replace any part of the equipment determined by Graco to be defective. This warranty applies only when the equipment is installed, operated and maintained in accordance with Graco's written recommendations.

This warranty does not cover, and Graco shall not be liable for general wear and tear, or any malfunction, damage or wear caused by faulty installation, misapplication, abrasion, corrosion, inadequate or improper maintenance, negligence, accident, tampering, or substitution of non-Graco component parts. Nor shall Graco be liable for malfunction, damage or wear caused by the incompatibility of Graco equipment with structures, accessories, equipment or materials not supplied by Graco, or the improper design, manufacture, installation, operation or maintenance of structures, accessories, equipment or materials not supplied by Graco.

This warranty is conditioned upon the prepaid return of the equipment claimed to be defective to an authorized Graco distributor for verification of the claimed defect. If the claimed defect is verified, Graco will repair or replace free of charge any defective parts. The equipment will be returned to the original purchaser transportation prepaid. If inspection of the equipment does not disclose any defect in material or workmanship, repairs will be made at a reasonable charge, which charges may include the costs of parts, labor, and transportation.

**THIS WARRANTY IS EXCLUSIVE, AND IS IN LIEU OF ANY OTHER WARRANTIES, EXPRESS OR IMPLIED, INCLUDING BUT NOT LIMITED TO WARRANTY OF MERCHANTABILITY OR WARRANTY OF FITNESS FOR A PARTICULAR PURPOSE.**

Graco's sole obligation and buyer's sole remedy for any breach of warranty shall be as set forth above. The buyer agrees that no other remedy (including, but not limited to, incidental or consequential damages for lost profits, lost sales, injury to person or property, or any other incidental or consequential loss) shall be available. Any action for breach of warranty must be brought within two (2) years of the date of sale.

**GRACO MAKES NO WARRANTY, AND DISCLAIMS ALL IMPLIED WARRANTIES OF MERCHANTABILITY AND FITNESS FOR A PARTICULAR PURPOSE, IN CONNECTION WITH ACCESSORIES, EQUIPMENT, MATERIALS OR COMPONENTS SOLD BUT NOT MANUFACTURED BY GRACO.** These items sold, but not manufactured by Graco (such as electric motors, switches, hose, etc.), are subject to the warranty, if any, of their manufacturer. Graco will provide purchaser with reasonable assistance in making any claim for breach of these warranties.

In no event will Graco be liable for indirect, incidental, special or consequential damages resulting from Graco supplying equipment hereunder, or the furnishing, performance, or use of any products or other goods sold hereto, whether due to a breach of contract, breach of warranty, the negligence of Graco, or otherwise.

## **FOR GRACO CANADA CUSTOMERS**

The Parties acknowledge that they have required that the present document, as well as all documents, notices and legal proceedings entered into, given or instituted pursuant hereto or relating directly or indirectly hereto, be drawn up in English. Les parties reconnaissent avoir convenu que la rédaction du présente document sera en Anglais, ainsi que tous documents, avis et procédures judiciaires exécutés, donnés ou intentés, à la suite de ou en rapport, directement ou indirectement, avec les procédures concernées.

# Graco Information

For the latest information about Graco products, visit [www.graco.com](http://www.graco.com).

For patent information, see [www.graco.com/patents](http://www.graco.com/patents).

**TO PLACE AN ORDER, contact your Graco distributor or call to identify the nearest distributor.**

**Phone: 612-623-6921 or Toll Free: 1-800-328-0211 Fax: 612-378-3505**

*All written and visual data contained in this document reflects the latest product information available at the time of publication.  
Graco reserves the right to make changes at any time without notice.*

Original instructions. This manual contains English. MM 3A6110

**Graco Headquarters:** Minneapolis

**International Offices:** Belgium, China, Japan, Korea

**GRACO INC. AND SUBSIDIARIES • P.O. BOX 1441 • MINNEAPOLIS MN 55440-1441 • USA**  
**Copyright 2020, Graco Inc. All Graco manufacturing locations are registered to ISO 9001.**

[www.graco.com](http://www.graco.com)  
Revision C, June 2025