

Installation and Operation



SoloTech™ Municipal Series Peristaltic Pumps

3A4064C
EN

Electric-powered hose pump for use in fluid transfer and metering applications. For professional use only.
Not approved for use in explosive atmospheres or hazardous locations unless otherwise stated in the model approvals section.



Important Safety Instructions

Read all warnings and instructions in this manual and in your Repair and Parts manual. **Save all instructions.**

*125 psi (0.9 MPa, 9 bar) Maximum Fluid Working Pressure
See page 3 for model part numbers and information.*

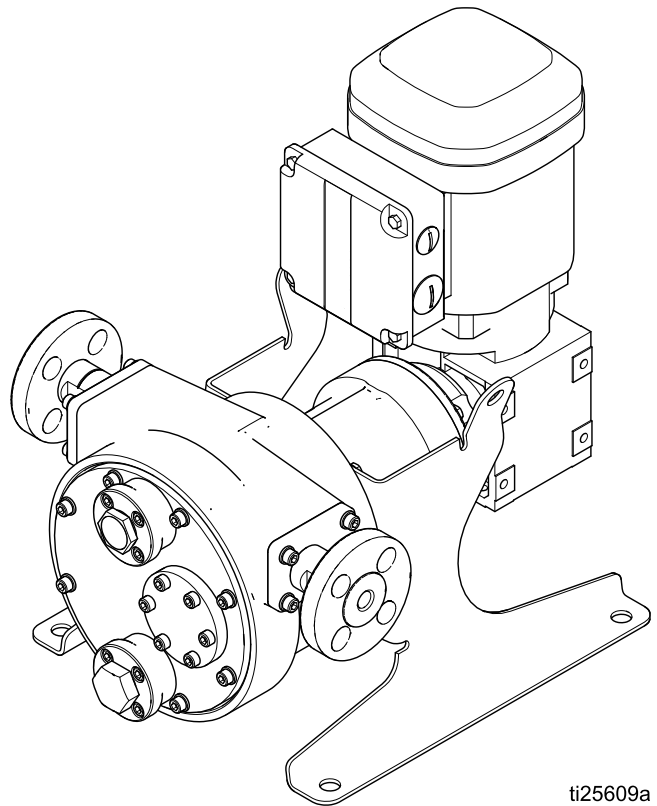

ti25609a



PROVEN QUALITY. LEADING TECHNOLOGY.

Contents

Related Manuals	2	VFD Control Panel	32
Configuration Number Matrix	3	Factory Settings.....	32
Warnings	4	Reverse Motor Direction	32
Installation.....	7	Adjust the Speed	32
Receiving and Handling.....	7	Graco Motor Control Operation (BLDC	
Moving the Pump	7	Models)	33
Location	8	Display	33
Mount the Pump and Controller.....	8	Graco Motor Control Software	
Mounting a Non-Graco Motor.....	8	Overview.....	34
Typical Installation	9	Operation Modes	37
Install the Hose	11	Maintenance	45
Install the Front Cover	11	Preventive Maintenance Schedule	45
Lubricate the Pump	13	Flushing	45
Fluid Connections	14	Pump Bearing Lubrication	45
Grounding	16	Hose Lubrication.....	45
Electrical Connections (AC Models)	17	Clean the Graco Motor Control	45
Electrical Connections (BLDC Models)	23	Upgrade Graco Motor Control	
Operation.....	28	Software	45
Pre-Start Checklist	28	Troubleshooting the Graco Motor Control	46
Initial Configuration (AC with VFD)	28	Diagnostic Information.....	47
Initial Configuration (BLDC with Graco		Power Line Voltage Surges	48
Motor Control)	28	Test Power Line with Multimeter	48
Start the Pump.....	29	Events.....	49
Running the Pump	29	Dimensions	52
BLDC Flow Calibration Procedure.....	30	Graco Motor Control Dimensions	55
BLDC Batch Calibration Procedure	30	Mounting Hole Layouts	57
Pressure Relief Procedure.....	31	Performance Data	58
Shutdown	31	Technical Data	61
Storage	31		
VFD Operation (AC Models).....	32		

Related Manuals

Manual Number	Title
3A4065	SoloTech Municipal Series Peristaltic Pumps, Repair and Parts

Configuration Number Matrix

Check the identification plate (ID) for the Configuration Number of your pump. Use the following matrix to define the components of your pump.

Sample Configuration Number: **ST23 MAC NR SS A1 A1 M**

ST	23	MAC	NR	SS	A1	A1	M
Pump Model	Hose Size	Motor	Hose Material	Barb Material	Roller	Housing	Options







Model	Hose Size		Motor/Gear Reducer	
ST	10	10 mm	HAC †	AC motor with high-speed gear reducer
	23	23 mm	MAC †	AC motor with medium-speed gear reducer
	26	26 mm	LAC †	AC motor with low-speed gear reducer
	30	30 mm	MPM †	Brushless DC (BLDC) motor with gear reducer









Hose Material/Color		Barb Material		Roller		Housing		Options	
BN	Nitrile (NBR), Yellow	PV	PVDF	A1	Aluminum	A1	Aluminum	M	Municipal Series
CS	Chlorosulfonated Polyethylene (CSM), Orange	SS	Stainless Steel						
NR	Natural Rubber, Black								

Approvals	
† These models are certified:	









Warnings

The following warnings are for the setup, use, grounding, maintenance and repair of this equipment. The exclamation point symbol alerts you to a general warning and the hazard symbol refers to procedure-specific risks. When these symbols appear in the body of this manual or on warning labels, refer back to these Warnings. Product-specific hazard symbols and warnings not covered in this section may appear throughout the body of this manual where applicable.

 WARNING	
   	<p>FIRE AND EXPLOSION HAZARD</p> <p>Flammable fumes, such as solvent and paint fumes, in work area can ignite or explode. Paint or solvent flowing through the equipment can cause static sparking. To help prevent fire and explosion:</p> <ul style="list-style-type: none"> • Use equipment only in well ventilated area. • Eliminate all ignition sources; such as pilot lights, cigarettes, portable electric lamps, and plastic drop cloths (potential static sparking). • Ground all equipment in the work area. See Grounding instructions. • Keep work area free of debris, including solvent, rags and gasoline. • Do not plug or unplug power cords, or turn power or light switches on or off when flammable fumes are present. • Use only grounded hoses. • Stop operation immediately if static sparking occurs or you feel a shock. Do not use equipment until you identify and correct the problem. • Keep a working fire extinguisher in the work area.
 	<p>ELECTRIC SHOCK HAZARD</p> <p>This equipment must be grounded. Improper grounding, setup, or usage of the system can cause electric shock.</p> <ul style="list-style-type: none"> • Turn off and remove power at main switch before disconnecting any cables and before servicing or installing equipment. • Connect only to grounded power source. • All electrical wiring must be done by a qualified electrician and comply with all local codes and regulations. • Wait five minutes for capacitor discharge before opening equipment. • Always use the recommended amount of genuine Graco hose lubricant to minimize build-up of static electricity.

 <h1 style="margin: 0;">WARNING</h1>	
  	<p>PRESSURIZED EQUIPMENT HAZARD Fluid from the equipment, leaks, or ruptured components can splash in the eyes or on skin and cause serious injury.</p> <ul style="list-style-type: none"> • Follow the Pressure Relief Procedure when you stop spraying/dispensing and before cleaning, checking, or servicing equipment. • Tighten all fluid connections before operating the equipment. • Check hoses, tubes, and couplings daily. Replace worn or damaged parts immediately.
 	<p>EQUIPMENT MISUSE HAZARD Misuse can cause death or serious injury.</p> <ul style="list-style-type: none"> • Do not operate the unit when fatigued or under the influence of drugs or alcohol. • Do not exceed the maximum working pressure or temperature rating of the lowest rated system component. See Technical Data in all equipment manuals. • Use fluids and solvents that are compatible with equipment wetted parts. See Technical Data in all equipment manuals. Read fluid and solvent manufacturer's warnings. For complete information about your material, request Safety Data Sheet (SDS) from distributor or retailer. • Turn off all equipment and follow the Pressure Relief Procedure when equipment is not in use. • Check equipment daily. Repair or replace worn or damaged parts immediately with genuine manufacturer's replacement parts only. • Do not alter or modify equipment. Alterations or modifications may void agency approvals and create safety hazards. • Make sure all equipment is rated and approved for the environment in which you are using it. • Use equipment only for its intended purpose. Call your distributor for information. • Route hoses and cables away from traffic areas, sharp edges, moving parts, and hot surfaces. • Do not kink or over bend hoses or use hoses to pull equipment. • Keep children and animals away from work area. • Comply with all applicable safety regulations.
 	<p>THERMAL EXPANSION HAZARD Fluids subjected to heat in confined spaces, including hoses, can create a rapid rise in pressure due to the thermal expansion. Over-pressurization can result in equipment rupture and serious injury.</p> <ul style="list-style-type: none"> • Open a valve to relieve the fluid expansion during heating. • Replace hoses proactively at regular intervals based on your operating conditions.

WARNING

 	<p>MOVING PARTS HAZARD Moving parts can pinch, cut or amputate fingers and other body parts.</p> <ul style="list-style-type: none"> • Keep clear of moving parts. • Do not operate equipment with protective guards or covers removed. • Pressurized equipment can start without warning. Before checking, moving, or servicing equipment, follow the Pressure Relief Procedure and disconnect all power sources.
 	<p>ENTANGLEMENT HAZARD Rotating parts can cause serious injury.</p> <ul style="list-style-type: none"> • Keep clear of moving parts. • Do not operate equipment with protective guards or covers removed. • Do not wear loose clothing, jewelry or long hair while operating equipment. • Equipment can start without warning. Before checking, moving or servicing equipment, follow the Pressure Relief Procedure and disconnect all power sources.
 	<p>TOXIC FLUID OR FUMES Toxic fluids or fumes can cause serious injury or death if splashed in the eyes or on skin, inhaled, or swallowed.</p> <ul style="list-style-type: none"> • Read the Safety Data Sheet (SDS) to know the specific hazards of the fluids you are using. • Store hazardous fluid in approved containers, and dispose of it according to applicable guidelines.
	<p>BURN HAZARD Equipment surfaces and fluid that is heated can become very hot during operation. To avoid severe burns:</p> <ul style="list-style-type: none"> • Do not touch hot fluid or equipment. • Store hazardous fluid in approved containers, and dispose of it according to applicable guidelines.
	<p>PERSONAL PROTECTIVE EQUIPMENT Wear appropriate protective equipment when in the work area to help prevent serious injury, including eye injury, hearing loss, inhalation of toxic fumes, and burns. Protective equipment includes but is not limited to:</p> <ul style="list-style-type: none"> • Protective eyewear, and hearing protection. • Respirators, protective clothing, and gloves as recommended by the fluid and solvent manufacturer.

Installation

<p>Installation of your pump involves potentially hazardous procedures. Only trained and qualified personnel who have read and who understand the information in this manual should install this equipment.</p>				

Receiving and Handling

Upon receipt of your pump:

- **Carefully inspect the pump to verify that no damage occurred during transit.** Check the packing list to ensure that all parts and accessories are present.

NOTE: If you find any damage or shortage, immediately notify your Graco distributor.

- Refer to the pump identification plate for the pump part number and series level.
- Leave the pump assembly crated, horizontal, and stored in a warm, dry location until you are ready to install it.

NOTE: To prevent hose damage if storing the pump more than 30 days, see [Storage, page 31](#).

Moving the Pump

<p>The pump is heavy. Handle it carefully. Careless handling can result in equipment damage and injury to personnel.</p>				

Keep the pump level and evenly supported when lifting or moving.

ST10 and ST23 Models: Pumps are equipped with 2 lifting holes on the support legs.

ST26 and ST30 Models: In addition to the 2 lifting holes on the support legs, some models are equipped with an additional lifting hole on the gearbox.

NOTICE

Be sure to use the lifting holes on the pump support legs. A second strap may be needed under the gear motor to keep the pump level.

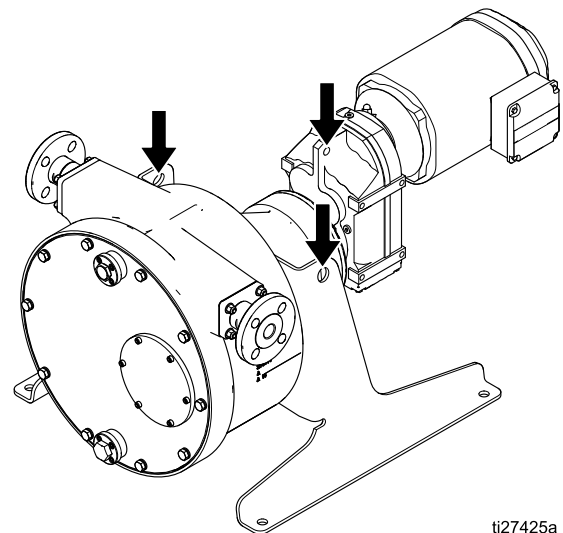

ti27425a

Figure 1 Lifting Hole Locations

Location

Allow sufficient space to permit easy access for maintenance and service, especially in front of the pump. The pump area should have adequate headroom and sufficient ventilation.

Before installing your pump, see [Dimensions, page 52](#), to ensure that the available space is sufficient for the pump, taking into account the following provisions:

- Dimension and weight of the pump package.
- Required moving and hoisting equipment.
- Possible piping layout, including space for removal and maintenance.
- Freedom of movement to operate the unit, read speed and pressure gauges, and provide adjustment and maintenance.
- Space required for lubrication.
- Space for removal of the hose from the unit.
- Location of the nearest drain or catch basin to collect used lubricant and fluid.

NOTE: The hose is serviced through the front cover. Provide sufficient work space in front of the pump when installing the unit.

Mount the Pump and Controller

NOTICE

The included gearbox is designed to be oriented as shipped. Reorienting the gearbox may cause the lubricating oil to drain, causing premature failure.

See [Mounting Hole Layouts, page 57](#).

Mount the pump on a flat surface that is 4 inches (102 mm) wider and longer than the pump base. When installing the pump, make sure that the surface of the foundation is smooth and free of debris. The foundation should be level and of sufficient depth and strength to adequately support the pump.

	ST10 and ST23	ST26	ST30
Hollow Bore Shaft Diameter (A)	20 mm	30 mm	35 mm
Bolt Circle Diameter (B)	100 mm	130 mm	165 mm
Flange Pilot Diameter (C)	80 mm	110 mm	130 mm
Mounting Hole Thread Size (D)	M6	M8	M10

Anchor bolts should be set into the concrete foundation. For best results, use anchor bolts made of corrosion resistant material such as stainless steel. Anchor bolt nuts should be of a different grade stainless steel to prevent galling. Level the pump as required, using shims.

Initially tighten the anchor bolts one eighth of a turn with a wrench. Do not fully tighten until after all piping has been connected.

Always run the pump with a control, either a VFD for AC models or a Graco Motor Control for BLDC models. Securely mount the controller. For pumps with BLDC motors, use the provided mounting tabs.

Mounting a Non-Graco Motor

To mount a non-Graco motor to a SoloTech pump, refer to this illustration and to the table that follows.

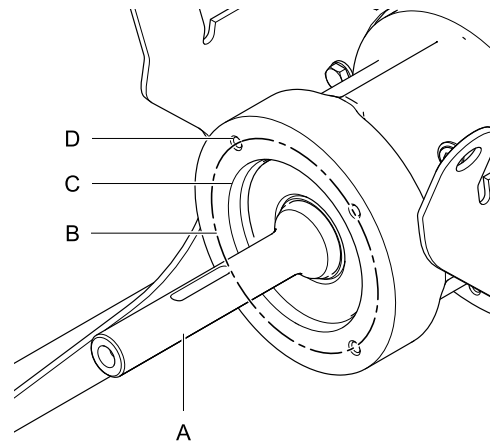

ti25610a //

Figure 2 Motor Mounting Dimensions

Typical Installation

The Typical Installation shown is only a guide for selecting and installing system components. Contact your Graco distributor for assistance in planning a system to suit your needs. Always use Genuine Graco Parts and Accessories. Be sure all accessories are adequately sized and pressure rated to meet the system's requirements.

KEY:	
A	Motor
B	SoloTech pump
C	Motor controller
D	Motor electrical box
E	Motor power connection
F	Main power connection
G	Motor feedback cable, used only for BLDC motors
H	Fluid inlet/outlet

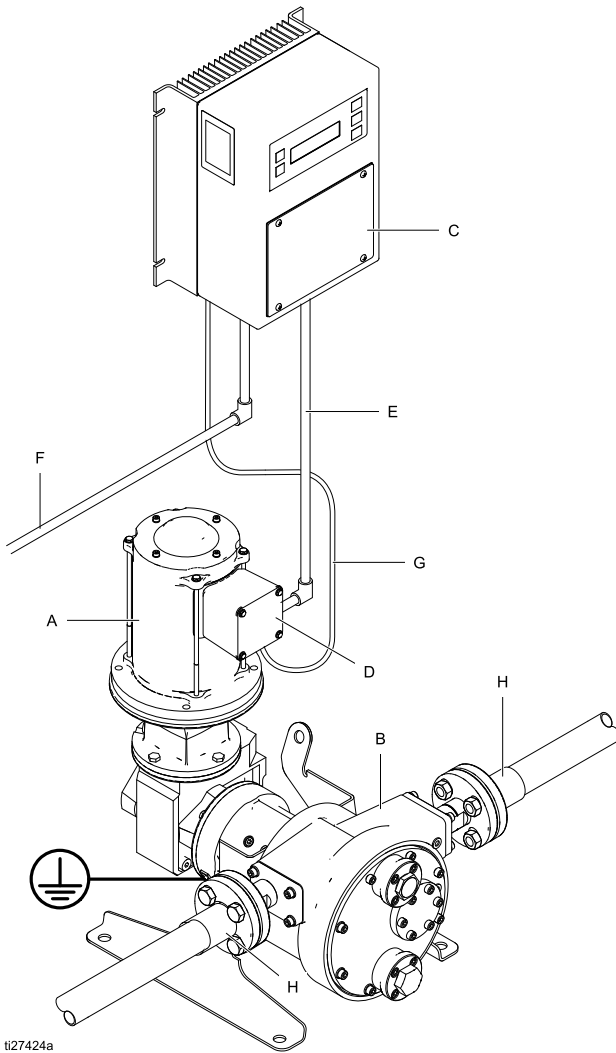

BLDC Pump with Graco Motor Control

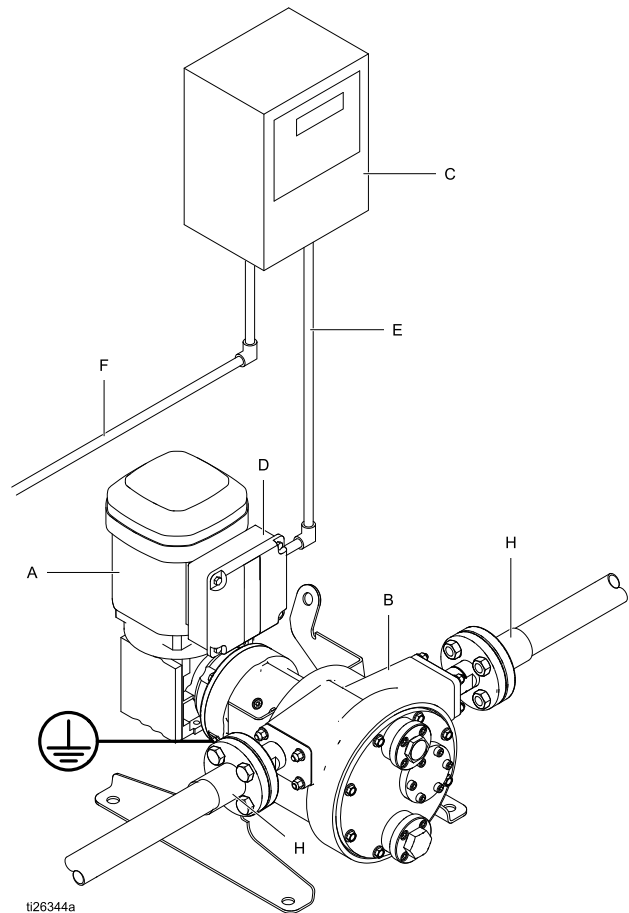

AC Pump with VFD

Graco Motor Control Component Identification

Used with pumps with BLDC motors.

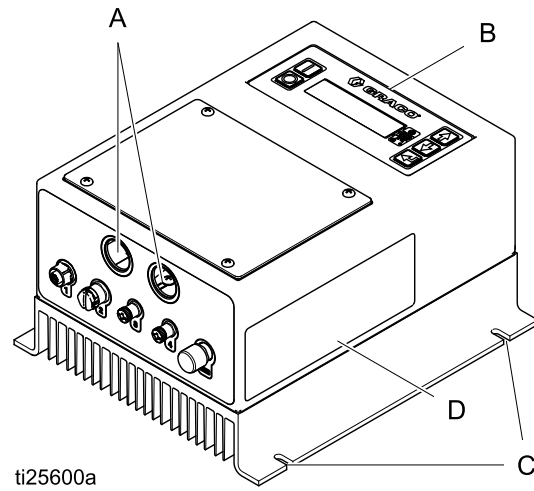

KEY:

- A Conduit Holes
- B Display Control Panel
- C Mounting Tabs
- D Warning Label

Install the Hose

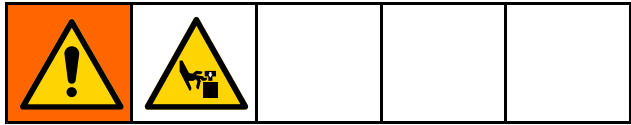

See Figure 3, page 12.

1. Disconnect the pump from the power source.
2. The roller must be moved to install the hose. Follow the directions for your pump to move the roller. Start at the 4 o'clock position and move the roller to the 8 o'clock position while pushing the hose in at the bottom. Be sure the hose is past the plane of the cover gasket.
 - a. **AC Models:** Loosen the screws and remove the motor fan cover. Turn the fan by hand to move the roller.

NOTE: Low RPM pumps and high ratio gearboxes may require many turns of the motor fan to move the roller.
 - b. **BLDC Models:**
 - i. Insert the shaft socket tool (59) into the back of the gearbox.
 - ii. Use a socket wrench to move the roller.

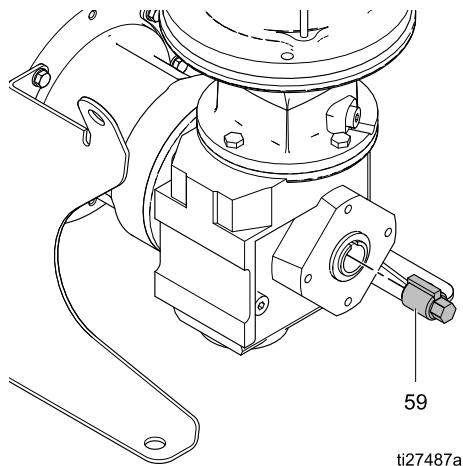

3. Use a rubber mallet if the hose is difficult to seat. Be sure that the hose is fully seated and will clear the cover.
4. **AC Models:** Reinstall the motor fan cover.
BLDC Models: Remove the socket from the gearbox.

Install the Front Cover

1. Scrape all debris from the gasket mating surfaces on the front cover (16) and the pump housing (1), then clean with acetone or brake cleaner to remove any residue. This is critical to ensure a leak-free assembly.
2. **ST10 and ST23:** Install the flangehead bolts (45) onto the front cover (16).
ST26 and ST30: Install the bolts (45), with flat washers (53) and lock washers (52), onto the front cover (16).
3. Place the gasket (15) on the front cover, over the screws.
4. Install the front cover (16) on the pump housing (1).
5. Torque the screws oppositely and evenly to the torque shown in the table.

Pump Model	Torque
ST10 and ST23	7 to 9 ft-lb (9.5 to 12.2 N•m)
ST26	16 to 20 ft-lb (21.7 to 27.1 N•m)
ST30	30 to 35 ft-lb (40.7 to 47.4 N•m)

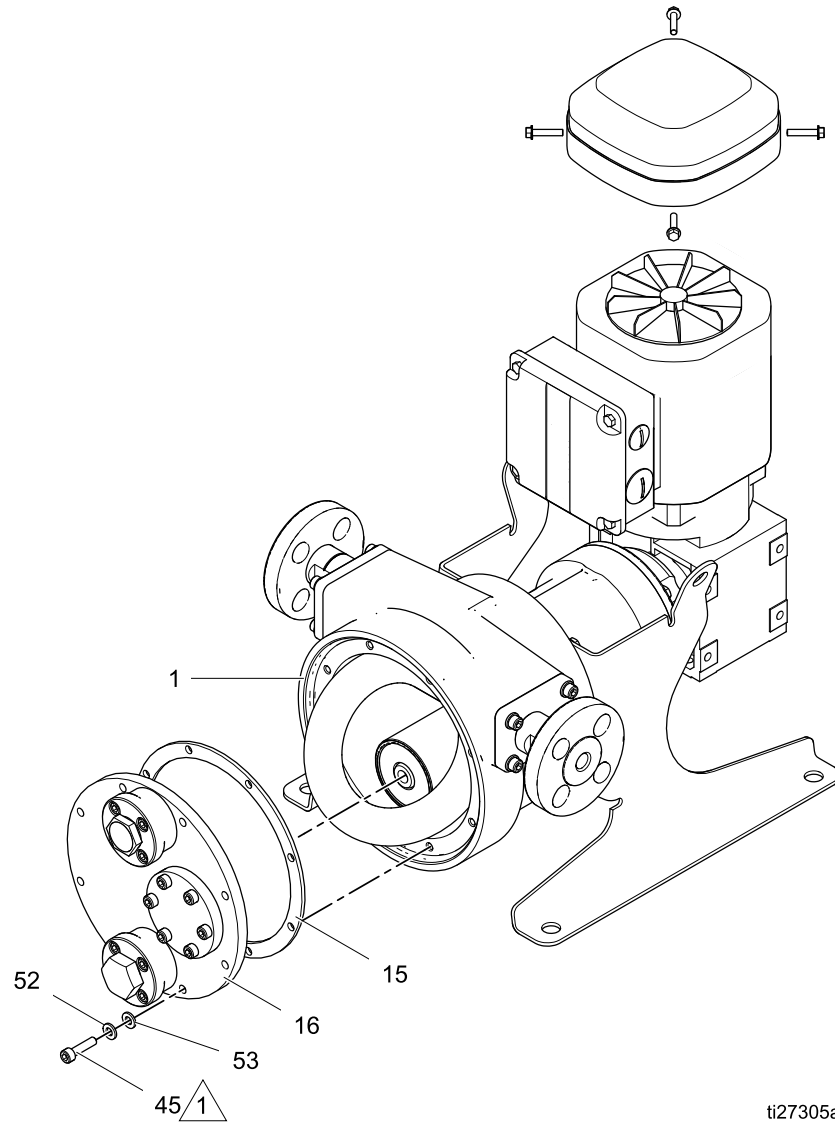

Figure 3 Install the Hose and Front Cover



Note **Description**



Tighten to the following torques.

- **ST10** and **ST23**: 7 to 9 ft-lb (9.5 to 12.2 N•m)
- **ST26**: 16 to 20 ft-lb (21.7 to 27.1 N•m)
- **ST30**: 30 to 35 ft-lb (40.7 to 47.4 N•m)

Lubricate the Pump

				
<p>To reduce the risk of fire or explosion that can result from static sparking or chemical incompatibility:</p> <ul style="list-style-type: none"> • Keep the pump properly filled with genuine Graco hose lubricant. • Verify that the hose lubricant is compatible with your pumped fluid. 				

NOTE: Silicone lubricant is available separately in a one gallon quantity, part number 24K685. If using silicone hose lubricant, mark or label the pump housing to reduce possibility of glycerin being used.

Before operating the pump, add hose lubricant to the pump housing as explained below. The lubricant reduces the risk of static sparking, reduces friction between the hose and the roller, and helps dissipate heat from the hose. Check the compatibility of the hose lubricant with your pumped fluid. Always use genuine Graco hose lubricant for maximum hose life.

NOTICE
Failure to add hose lubricant to the pump housing will result in reduced hose life.

1. Disconnect the pump from the power source.
2. Unscrew the vent plug near the top of the front cover.
NOTE: If using the leak sensor, perform [Leak Sensor, page 15](#) instead of step 3. When done, continue with step 4 below.
3. Wrap the drain plug threads with PTFE tape and screw it into the drain port. Be sure that it is tight to prevent leakage of lubricant.
4. Use a funnel with a flexible spout to add hose lubricant through the vent port. The lubricant level must cover the bottom of the roller.

NOTE: If you are using the optional leak detector, overfilling may cause nuisance tripping of the sensor.

See the table below for the correct amount of lubricant for your pump. Pre-measure the correct amount to help prevent overfilling.

Pump Model	Amount of Hose Lubricant (approximate)
ST10	4.5 fl oz (130 ml)
ST23	12 fl oz (350 ml)
ST26	27 fl oz (800 ml)
ST30	34 fl oz (1000 ml)

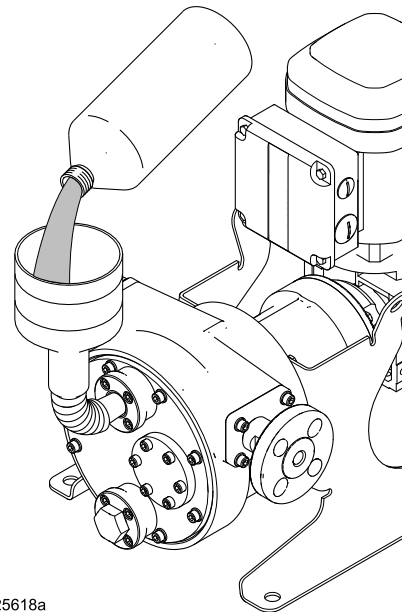

ti25618a

Figure 4 Fill Pump With Hose Lubricant

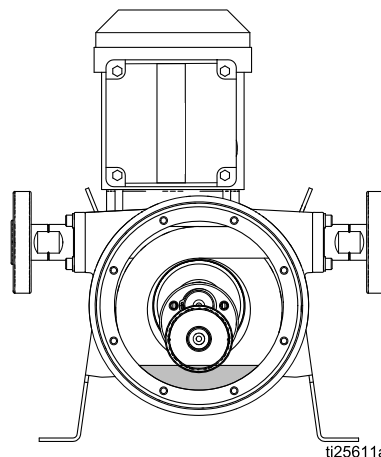



ti25611a

Figure 5 Hose Lubricant Level

5. Wrap the vent plug threads with PTFE tape and screw it into the vent port.

NOTICE
The vent and drain port threads are aluminum. To help prevent galling, inspect the bolt threads for foreign material and clean or replace if necessary.

Fluid Connections

				
<p>Excessive stress on the pump inlet or outlet connections can cause serious injury or equipment failure. The fluid inlet and outlet lines must be independently supported. The pipe supports should be located as close to the pump as possible.</p>				

The pump roller can move either clockwise or counter-clockwise, depending on the direction of motor rotation. The direction of roller movement determines the orientation of the fluid inlet and outlet. See the table below.

Roller Direction (as viewed through sightglass)	Fluid Inlet	Fluid Outlet
Clockwise	Left	Right
Counter-clockwise	Right	Left

NOTE: If your installation requires the fluid inlet and outlet positions to be reversed, see [Reverse Motor Direction, page 32](#), for systems that are controlled with a VFD. See menu G211, Set Pump Direction, for systems controlled with the Graco Motor Control.

Fluid Inlet and Outlet Lines

Inlet Line

Locate the pump as close to the fluid source as possible. The inlet piping should be at least the

same diameter as the pump inlet connection and should have a straight run of pipe that is a minimum of 8 to 10 pipe diameters long. Inlet piping must be airtight and suitable for both pressure and vacuum. If possible, provide a larger diameter pipe than the pump inlet connection.

Install a shutoff valve near the pump inlet to isolate the unit for service and repair. Never install a check valve on the inlet side of the pump. A compound vacuum/pressure gauge can be installed to monitor pump performance.

Outlet Line

The pump outlet piping should be a similar diameter as the outlet connection. Avoid sudden changes in pipe diameter by using concentric taper increasers. As much as possible, provide a straight run of pipe downstream of the pump outlet.

NOTICE
<p>Install a pressure relief valve upstream of a shutoff valve at the pump outlet, to prevent over-pressurization that can damage the pump or the hose.</p>

Install the pressure relief valve near the pump outlet. Downstream of the pressure relief valve, install a shutoff valve to isolate the unit for service and repair. Install a pressure gauge to monitor pump performance. A check valve is not recommended on the outlet of the pump since the pump acts as its own check valve.

Table 1 Graco Flange Dimensions

Dimension	ST10	ST23 and ST26	ST30
Outer Diameter	3.54 in. (90 mm)	4.25 in. (108 mm)	4.92 in. (125 mm)
Bolt Circle Diameter	2.30–2.56 in. (58–65 mm)	2.95–3.13 in. (75–80 mm)	3.35–3.54 in. (85–90 mm)
Bolt Size	1/2 in. (13 mm)		

Table 2 Mating Flange Sizes

Standard	ST10	ST23 and ST26	ST30
DIN PN16	010–3/8 in.	020–3/4 in.	025–1 in.
ANSI 150	1/2 NPS	1 NPS	1 1/4 NPS
JIS 10K	010–3/8 in.	020–3/4 in.	025–1 in.

Leak Sensor

The optional leak sensor (Kit 24Y849) is highly recommended to avoid operating the pump with a ruptured hose. Remove plug 29. To install the leak sensor, follow the instructions that come with the kit. See also [Leak Sensor Wiring \(AC Models\), page 22](#), or [Leak Sensor Wiring \(BLDC Models\), page 27](#).

ST10 & ST23

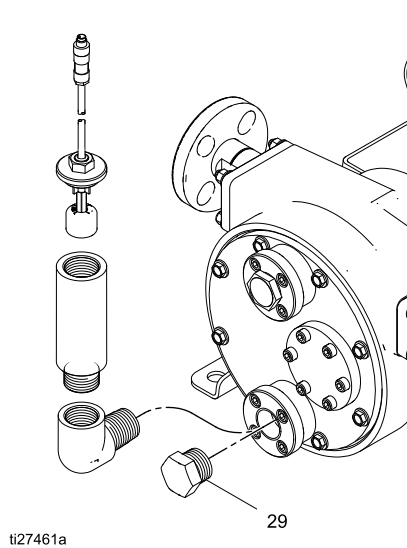

ST26 & ST30

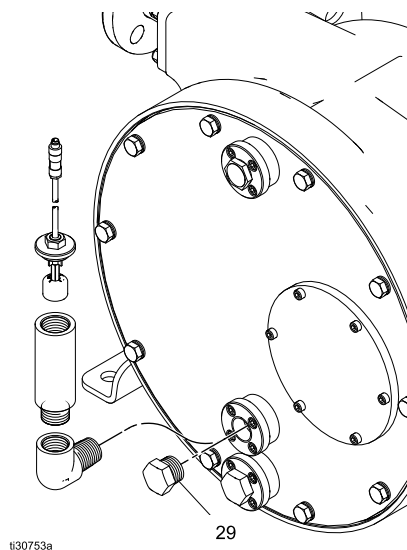

Figure 6 Install Optional Leak Sensor

Flush Connections

Line flushing connections are recommended when pumping slurries or liquids with a high concentration

of solids that tend to settle when the pump is turned off.

NOTE: Accumulation of solids in the hose after shutdown can reduce hose life because the hose will experience high stress when restarting the pump.

Pulsation Dampeners

Hose pumps sometimes require the use of pulsation dampeners on either the inlet or outlet to increase the hose life during operation. A pulsation dampener acts to absorb the energy of the pulsations that the pump produces so that these forces do not act upon the hose. Your Graco distributor will assist you in selecting the proper size and application of these devices in your system.

If your operation does require pulsation dampeners, mount them as close to the inlet and/or outlet of the pump as possible. Do not support the weight of the dampeners on the pump connections. These devices must be independently supported.



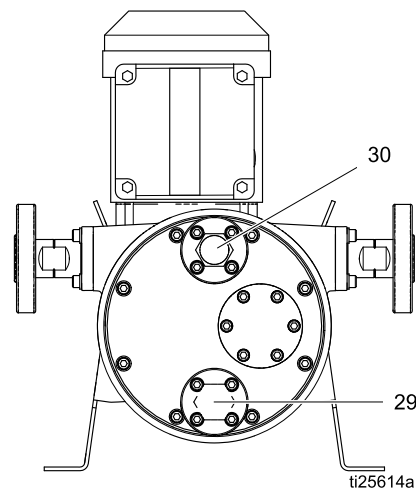

Outlet pulsation dampeners work best when there is some back pressure in the outlet line. Pulsation dampeners do not work efficiently at low outlet pressures or when the pump discharges directly to the atmosphere.

Drain and Vent Plugs

The pump is equipped with a low point drain (29) and a vent (30). The drain is typically plugged with a stainless steel plug. The vent prevents a buildup of excess pressure in the pump housing.



Grounding

				
<p>This equipment must be grounded to reduce the risk of static sparking and electric shock. Electric or static sparking can cause fumes to ignite or explode. Improper grounding can cause electric shock. Grounding provides an escape wire for the electric current.</p>				

1. **Pump:** Loosen the grounding screw. Insert one end of a 12 AWG (3.3 mm²) minimum ground wire behind the ground screw and tighten the screw securely. Connect the clamp end of the grounding wire to a true earth ground. A ground wire and clamp, Part 238909, is available from Graco. Also Ground the pump through a proper electrical connection. For AC Models, see [Wire Connections at the Motor, page 17](#). For BLDC Models, see [BLDC Motor Wiring, page 25](#).

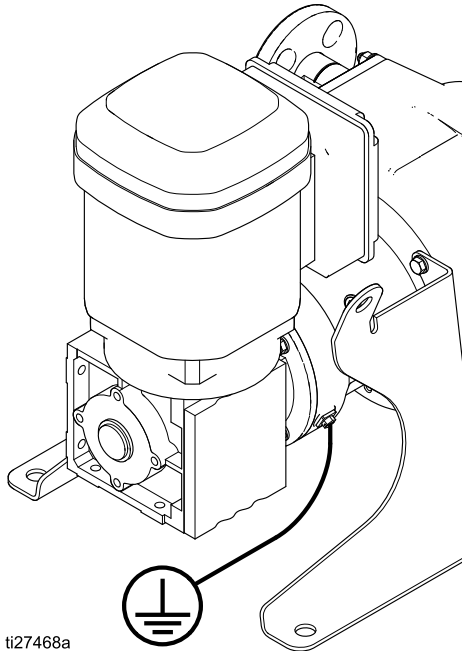



2. **Fluid hoses:** Use only electrically conductive hoses with a maximum of 500 ft. (150 m) combined hose length to ensure grounding continuity. Check the electrical resistance of hoses. If total resistance to ground exceeds 25 megohms, replace hose immediately.
3. **Fluid supply container:** Follow your local code.
4. **All solvent pails used when flushing:** Follow local code. Use only metal pails, which are conductive. If your fluid is incompatible with a metal pail, use a conductive, grounded pail liner. Do not place the pail on a non-conductive surface, such as paper or cardboard, which interrupts the grounding continuity.
5. **Motor Controller** Ground through a proper electrical connection.
 - a. **VFD:** See [Wire Connections at the Variable Frequency Drive \(VFD\), page 19](#).
 - b. **Graco Motor Control:** See [Controller Wiring, page 26](#).

Check your system electrical continuity after the initial installation, and then set up a regular schedule for checking continuity to be sure proper grounding is maintained. The resistance should not exceed 1 ohm.

Electrical Connections (AC Models)

Wire Connections at the Motor

				
<p>To avoid injury from fire, explosion, or electric shock, all electrical wiring must be done by a qualified electrician and comply with all local codes and regulations.</p>				

NOTE: Graco recommends the use of a motor soft starter or a VFD in the electrical circuit for all installations. See the motor manufacturer's recommendations for proper installation when using either of these components. In all cases, make sure all products are installed in accordance with local codes and regulations.

NOTICE
<p>To avoid equipment damage, do not plug the motor directly into a wall socket. The motor must be wired to a VFD.</p>

The motor must be wired to the VFD. Install the wiring at the motor as follows:

1. Remove 4 bolts to open the motor's electrical box.

2. Internal Wiring:

- a. **For 460V Motors:** The motor typically comes wired for 460 V. If this is the voltage you want, the existing wiring can remain as it is.

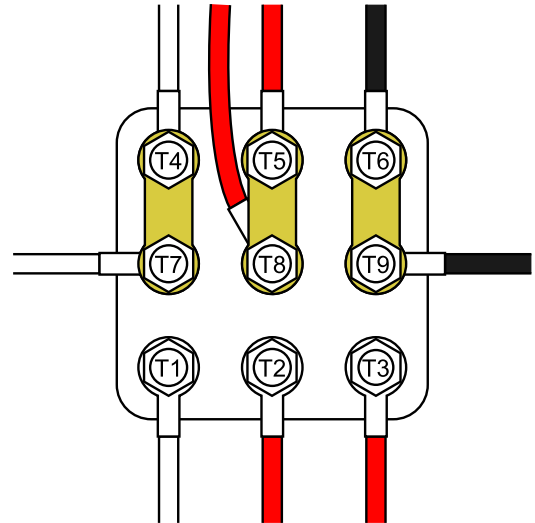
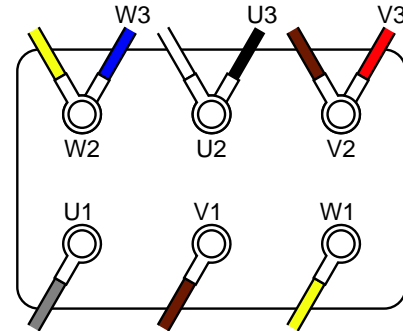

Installation

- b. **For 6-post 230V Motors:** Move the black wire (U3), the red wire (V3) and the blue wire (W3) as shown. Bridge W2, U2, and V2 as shown.

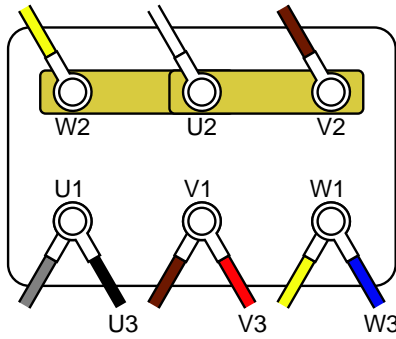

- c. **For 9-post 230V Motors:** Move the bridges to the locations shown.

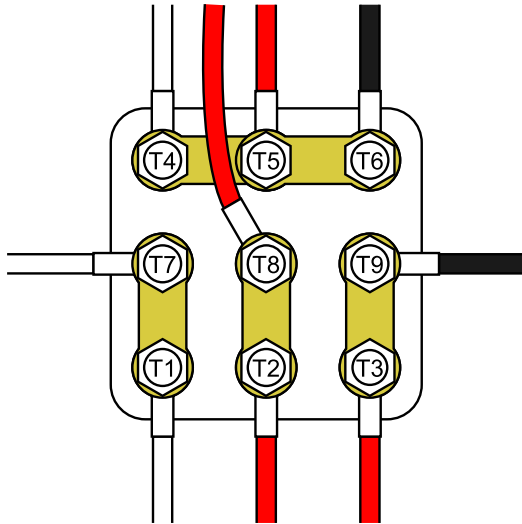

3. Install wiring system with proper liquid-tight connections in one of the ports at the bottom of the motor box.

4. Connect the ground wire to the ground screw. Torque the M5 stud to 17.7 in-lb (2.0 N•m).
5. Power Connections:

- a. **For 460V Motors:** Connect power wires L1, L2 and L3, as shown.

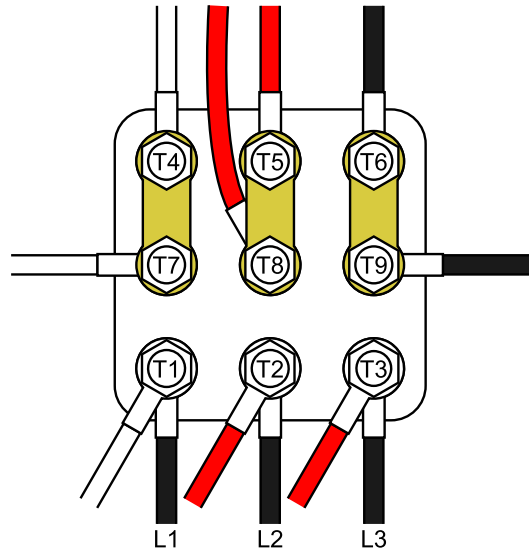
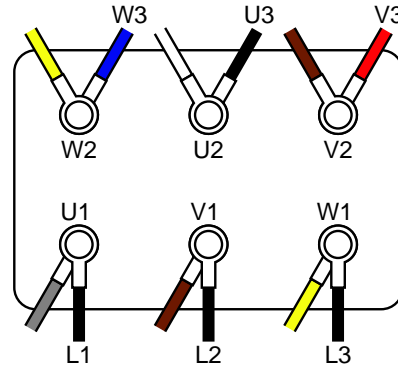

- b. **For 230V Motors:** Connect power wires L1, L2 and L3 as shown.

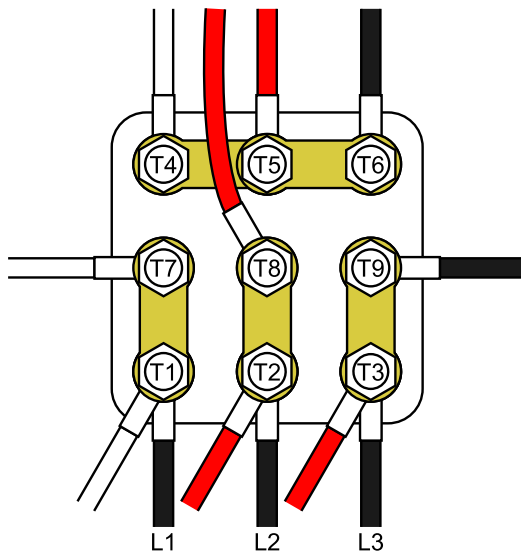
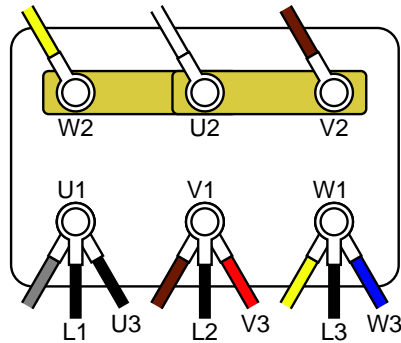

- Torque terminals to 14.2 in-lb (1.6 N•m). **Do not overtorque.**
- Close the motor electrical box. Torque the screws to 20 in-lb (2.3 N•m).

Wire Connections at the Variable Frequency Drive (VFD)

<p>To avoid injury from fire, explosion, or electric shock, all electrical wiring must be done by a qualified electrician and comply with all local codes and regulations.</p> <ul style="list-style-type: none"> • Disconnect power before servicing. • Wait 5 minutes for capacitor discharge before opening. 				

NOTE: For variable speed control, the motor must be wired to a VFD. Follow the instructions in the VFD manufacturer's manual.

If you purchased an optional Graco VFD, install the wiring at the VFD as follows:

- Connect the wires to the motor. See [Wire Connections at the Motor, page 17](#).
- Open the VFD's electrical box.
- Install the wiring system with proper liquid-tight connections for incoming supply power and for outgoing motor power.
- Connect the ground wires for the VFD and for the motor to the ground screw.
- Connect the wires from the motor terminals to the matching terminals in the VFD box, as shown.

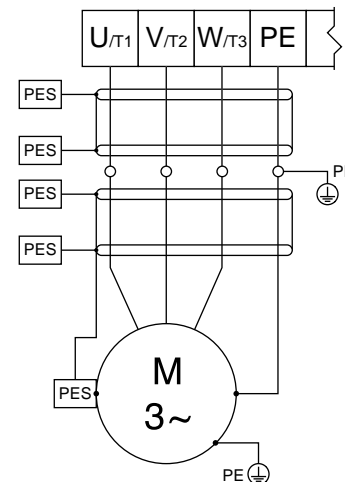

Figure 7 Wire Connections from the Motor to the VFD

- Connect the power supply wires to the power terminals in the VFD box. See Table 3 and Figs. 8–12, as applicable for your system.
- Close the VFD electrical box.
- Perform the VFD configuration as specified in [Initial Configuration \(AC with VFD\), page 28](#).

Table 3 Main Power Connections at the VFD

VFD Part No.	HP	Nominal Input Voltage	Input Voltage Range	Nominal Output Voltage †	See Figure No.
16K905	0.5	120 Vac, 1 phase	90–132 Vac	240 Vac, 3 phase	Fig. 8
16K905	0.5	240 Vac, 1 phase	170–264 Vac	240 Vac, 3 phase	Fig. 9
16K906	0.5	208–240 Vac, 1 phase	170–264 Vac	208–240 Vac, 3 phase	Fig. 10
16K906	0.5	208–240 Vac, 3 phase	170–264 Vac	208–240 Vac, 3 phase	Fig. 11
16K907	1.0	120 Vac, 1 phase	90–132 Vac	240 Vac, 3 phase	Fig. 8
16K907	1.0	240 Vac, 1 phase	170–264 Vac	240 Vac, 3 phase	Fig. 9
16K908	1.0	208–240 Vac, 1 phase	170–264 Vac	208–240 Vac, 3 phase	Fig. 10
16K908	1.0	208–240 Vac, 3 phase	170–264 Vac	208–240 Vac, 3 phase	Fig. 11
16K909	1.5	120 Vac, 1 phase	90–132 Vac	240 Vac, 3 phase	Fig. 8
16K909	1.5	240 Vac, 1 phase	170–264 Vac	240 Vac, 3 phase	Fig. 9
16K910	1.5	208–240 Vac, 1 phase	170–264 Vac	208–240 Vac, 3 phase	Fig. 10
16K910	1.5	208–240 Vac, 3 phase	170–264 Vac	208–240 Vac, 3 phase	Fig. 11
16K911	2.0	208–240 Vac, 1 phase	170–264 Vac	208–240 Vac, 3 phase	Fig. 10
16K911	2.0	208–240 Vac, 3 phase	170–264 Vac	208–240 Vac, 3 phase	Fig. 11
16K912	2.0	400–480 Vac 3 phase	340–528 Vac	400–480 Vac 3 phase	Fig. 12
16K696	3.0	208–240Vac, 1 phase	170–264 Vac	208–240Vac, 3 phase	Fig. 10
17K696	3.0	208–240Vac, 3 phase	170–264 Vac	208–240Vac, 3 phase	Fig. 11
17K697	3.0	400–480 Vac 3 phase	340–528 Vac	400–480 Vac 3 phase	Fig. 12

† Output voltage is dependent on input voltage.

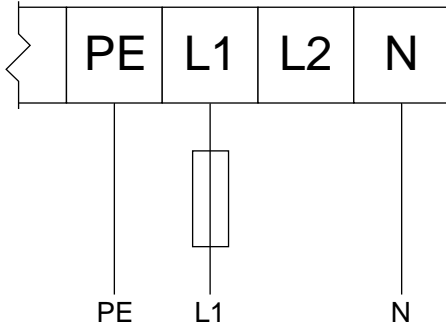

Figure 8 120 Vac 1 Phase Input/240 Vac 3 Phase Output

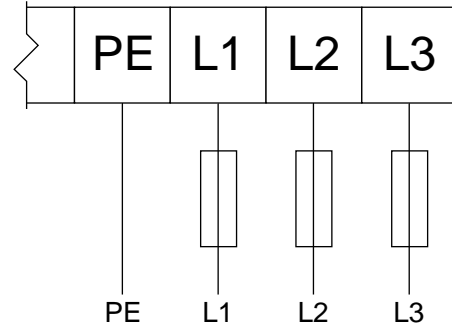

Figure 11 190 Vac, 208-240 Vac 3 Phase Input/190 Vac, 208-240 Vac 3 Phase Output

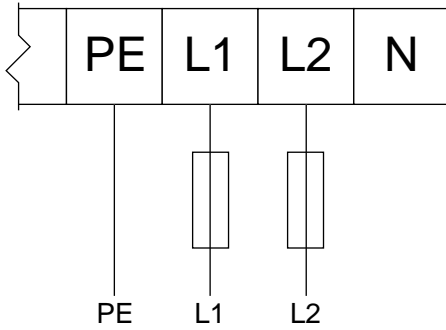

Figure 9 240 Vac 1 Phase Input/240 Vac 3 Phase Output

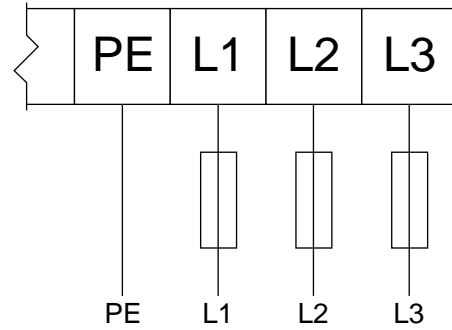

Figure 12 380 Vac, 400-480 Vac 3 Phase Input/380 Vac, 400-480 Vac 3 Phase Output

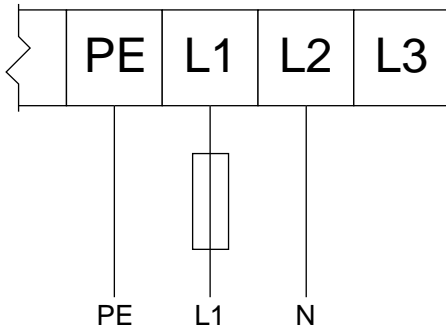

Figure 10 208-240 Vac 1 Phase Input/208-240 Vac 3 Phase Output

Leak Sensor Wiring (AC Models)

NOTE: Leak Sensor Electrical Ratings:

- Voltage: 36 VDC/30VAC
- Current: 0.5A
- Normally closed

Follow these instructions to wire the optional Leak Sensor Kit 24Y849 to the Graco VFD.

1. Select and purchase a cable from the following table, determined by the cable routing distance between the pump and the VFD.

Part Number	Cable Length
17H389	9.8 ft, 3.0 m
17H390	24.6 ft, 7.5 m
17H391	52.5 ft, 16 m

2. See [Leak Sensor, page 15](#), to install the leak sensor. Connect the selected cable to the installed leak sensor.

3. Turn off power to the VFD.
4. Open the access cover on the VFD.
5. Wire black lead to terminal 1 on the rail.
6. Wire blue lead to terminal 4 on the rail.

NOTE: The white and brown wires in the cable are not used and must be individually terminated.

7. Connect a jumper wire between terminals 4 and 13A.
8. Close the access cover.
9. Turn on power to the VFD.
10. On the VFD display, go to screen P100.
11. Change the value to 4 and press the Mode button.
12. Go to screen P121.
13. Change the value to 8 and press the Mode button.

Electrical Connections (BLDC Models)

				
<p>To avoid injury from fire, explosion, or electric shock, all electrical wiring must be done by a qualified electrician and comply with all local codes and regulations.</p>				

connections for CAN cable and system-specific I/O devices. Connect according to the following table to ensure that the cables in your system are connected to the correct connectors on the Graco Motor Control.

NOTE: To maintain enclosure rating use approved Type 4 (IP66) fittings and ensure either a cable or plug is attached to all M12 and M8 connectors.

Connect Cables

Always run your BLDC pump with a Graco Motor Control. The Graco Motor Control provides several

Table 4 Connector Information

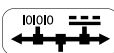
Graco Motor Control Label Identifier	Connector Type	Connector Use
1	M12, 8-position, Female	Motor position and temperature feedback. Connect only to Graco BLDC motor with Graco cabling. <ul style="list-style-type: none"> • 17F709 (1.0 ft; 0.3 m) • 15Y051 (9.8 ft; 3.0 m) <i>included</i> • 16X521 (24.6 ft; 7.5 m) • 16P791 (52.5 ft; 16 m)
2 (Spare)	M12, 5-position, Female, B-Code	Not currently used.
3 and 4	M8, 4-position, Female	See Table 5 for pinout and power specifications; must be supplied by a Class 2 power source.
	M12, 5-position, Male, A-Code	CAN Power and Communication. Connect only to Graco supplied cabling and modules. Connect to a maximum 30 VDC, Class 2 power source.

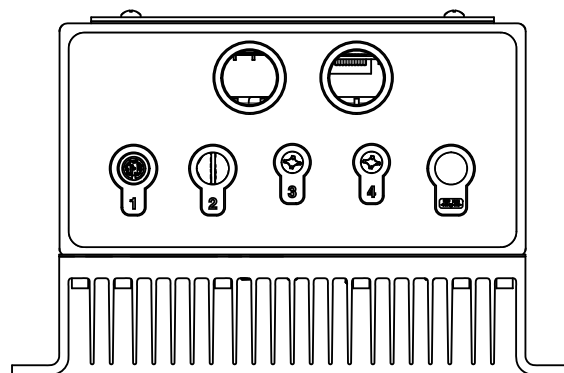



ti25593a

Table 5 Connector 3 and 4 Specifications

Connector	Pin*	Function	Ratings
3 (Leak Sensor and Spare Input)	1 (Brown)	5VDC Supply	5 VDC, 20 mA Max
	2 (White)	Digital Input (Spare)	Voltage Range: 5-24 VDC Max Voltage: 30 VDC Logic High: > 1.6 VDC Logic Low: < 0.5 VDC Internally Pulled-Up to 5VDC
	3 (Blue)	Common	
	4 (Black)	Digital Input (Leak Signal)	Voltage Range: 5-24 VDC Max Voltage: 30 VDC Logic High: > 1.6 VDC Logic Low: < 0.5 VDC Internally Pulled-Up to 5VDC
4 (PLC Control)	1 (Brown)	Common	
	2 (White)	Digital Input (Start/Stop Signal)	Voltage Range: 12-24 VDC Max Voltage: 30 VDC Logic High: > 6.0 VDC Logic Low: < 4.0 VDC Internally Pulled-Up to 12 VDC
	3 (Blue)	Common	
	4 (Black)	Analog Input (Flow Signal)	Input Impedance: 250 Ohms Current Range: 4-20 mA Max Voltage: 12.5 VDC (continuous); 30 VDC (momentary) Max Current: 50 mA

* Wire colors correspond to Graco cables.

BLDC Motor Wiring

				
<p>To avoid injury from fire, explosion, or electric shock, all electrical wiring must be done by a qualified electrician and comply with all local codes and regulations.</p>				

See [Wiring Tips, page 27](#), for additional information on wire routing.

NOTE: Use only copper wire with an insulation rating of 75°C or higher.

1. Use a 1/4 in. socket to remove the cover from the motor electrical box.
2. Install wiring system with proper liquid-tight connections to the motor electrical box.

3. Connect the Graco Motor Control to the motor. Use minimum 14 AWG (2.5 mm²) wire. Use a 7 mm socket to loosen the terminal studs.
 - a. Connect M1(U) of the Graco Motor Control to U1 of the motor.
 - b. Connect M2(V) of the Graco Motor Control to V1 of the motor.
 - c. Connect M3(W) of the Graco Motor Control to W1 of the motor
 - d. Use an 8 mm socket to loosen the ground stud. Connect the Protective Earth of the Graco Motor Control to the Protective Earth of the motor .
4. Torque to the following specifications:
 - a. Torque the M4 studs (U1, V1, and W1) to 15 in-lb (1.7 N•m).
 - b. Torque the M5 stud (Protective Earth) to 20 in-lb (2.3 N•m).
5. Connect the M12–8 Pin cable to Connector 1 on the motor.
6. Put the cover on the motor electrical box. Torque the bolts to 20 in-lb (2.3 N•m).

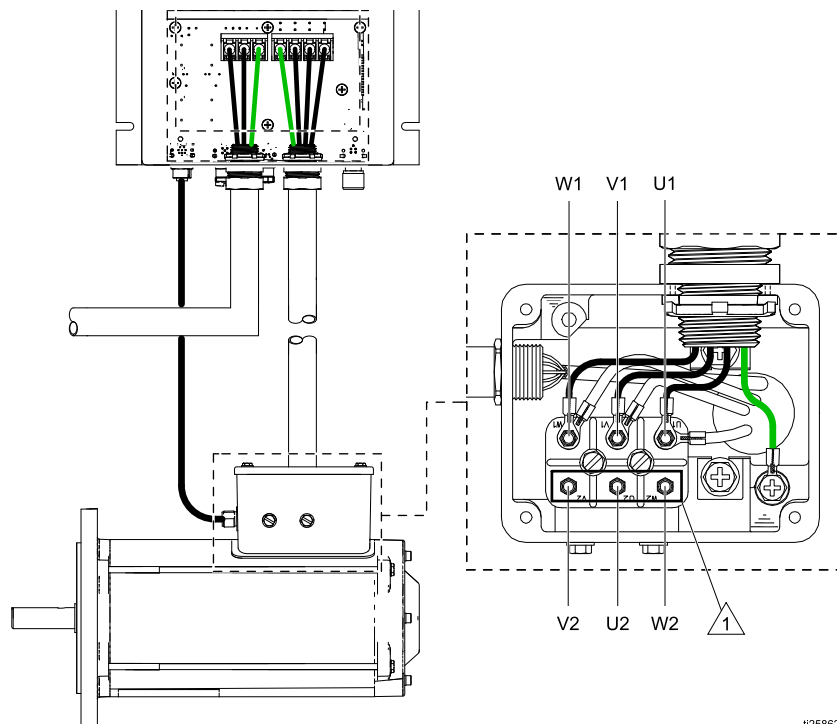







Figure 13 Wiring to Motor

 Do not use.

1125862b

Controller Wiring

				
<p>To avoid injury from fire, explosion, or electric shock, all electrical wiring must be done by a qualified electrician and comply with all local codes and regulations.</p> <ul style="list-style-type: none"> • Disconnect power before servicing. • Wait 5 minutes for capacitor discharge before opening. 				

See [Wiring Tips, page 27](#), for additional information on wire routing.

- Branch circuit protection is not provided by the device. Branch circuit protection must be provided in accordance with local codes and regulations.
 - This product can cause a DC current in the protective earthing conductor. Where a residual current-operated protective (RCD) or monitoring (RCM) device is used for protection in case of direct or indirect contact, only an RCD or RCM of Type B is allowed on the supply side of this product.
 - Leakage Current may exceed 3.5mA AC. The minimum size of the protective earthing conductor shall comply with the local safety regulations for high protective earthing conductor current equipment.
 - Use only copper wire with an insulation rating of 75°C (167°F) or higher.
 - Torque terminals to 20 in-lb (2.3 N•m).
1. Remove the Graco Motor Control access panel.

2. Install wiring system with proper liquid-tight connections for incoming supply power and for outgoing motor power.

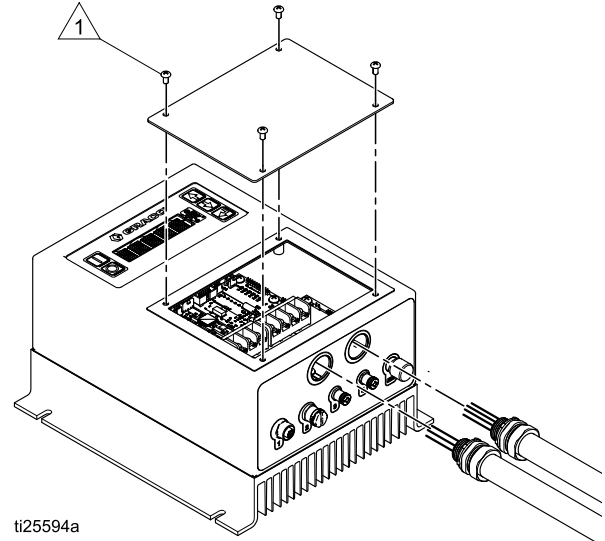



ti25594a

- 1 To ensure a proper water-tight seal, torque screws to 20 in-lb (2.3 N•m).

3. Connect the Graco Motor Control to the motor. Use minimum 14 AWG (2.1 mm²) wire.
 - a. Connect M1(U) of the Graco Motor Control to U1 of the motor.
 - b. Connect M2(V) of the Graco Motor Control to V1 of the motor.
 - c. Connect M3(W) of the Graco Motor Control to W1 of the motor
 - d. Connect the Protective Earth of the Graco Motor Control to the Protective Earth of the motor .

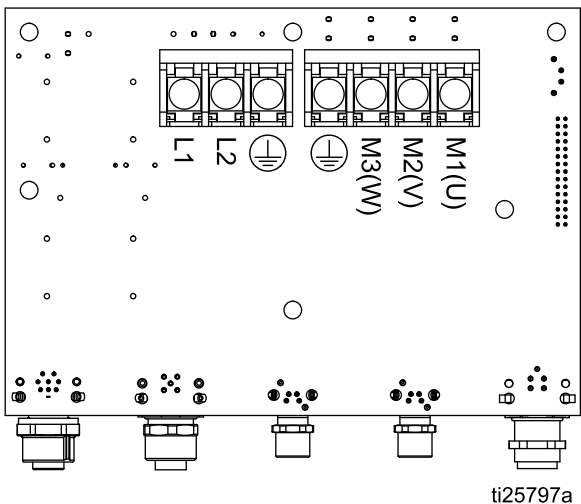
- Connect M12-8 Pin cable to Connector 1 on the Graco Motor Control.



- Connect 120/240 VAC single-phase line power to L1 and L2/N. Connect supply ground to . Use minimum 12 AWG (3.3 mm²) wire when the system is configured for a 16A circuit and 14 AWG (2.1 mm²) when configured for a 12A circuit.
- Reinstall the access panel. Torque the screws to 20 in-lb (2.3 N•m).

Leak Sensor Wiring (BLDC Models)

NOTE: Leak Sensor Electrical Ratings:

- Voltage: 36 VDC/30VAC
- Current: 0.5A
- Normally closed

Follow these instructions to wire the optional Leak Sensor Kit 24Y849 to the Graco Motor Control.

- Select and purchase a cable from the following table, determined by the cable routing distance between the pump and the Graco Motor Control.

Part Number	Cable Length
121683	9.8 ft, 3.0 m
17H349	24.6 ft., 7.5 m
17H352	52.5 ft, 16 m

- See [Leak Sensor, page 15](#), to install the leak sensor. Connect the selected cable to the installed leak sensor.

- Connect leak sensor (with optional extension cable) to Graco Motor Control Connector 3.
- Go to Menu G206 in the Setup Screens (see [Setup Mode, page 37](#)). Set Leak Detection Type to indicate whether the system should warn that there's a leak but keep running (Deviation) or if it should stop the pump (Alarm).

PLC Wiring

BLDC motors can be controlled remotely using a PLC.

NOTE: For “Stop Only” or “Start/Stop” control, skip steps 3, 5, and 6. See [Discrete Input Control in Graco Motor Control Software Overview, page 34](#), for more information regarding control function. Wire colors correspond to Graco cabling.

- Connect the PLC Control cable to Graco Motor Control connector 4.
- Connect Pin 2 (Signal, white wire) and Pin 1 (Common, brown wire) to the Start/Stop signal.
- Connect Pin 4 (Signal, black wire) and Pin 3 (Common, blue wire) to the Flow signal (4–20mA).
- Set menu G209 to the desired type of external control.
- Set the desired minimum and maximum flow rates in menus G240 and G241.
- Set the analog low and high inputs in menus G212 and G213.

Wiring Tips

- Use a grounded or shielded metal conduit for power cabling.
- Use the shortest possible cables or wires for incoming power.
- Use the shortest possible cables or wires between the controller and the motor.
- Route low-voltage cables away from high-power cables or wires or other known electromagnetic interference (EMI) sources. If cables must cross, cross at a 90° angle.
- The Graco Motor Control used with BLDC motors has an integrated line filter, so no external filter is necessary.

Operation

Pre-Start Checklist

Verify each of the following items before starting the pump.

- **DEBRIS:** Ensure that the fluid inlet line and fluid supply are free of dirt, debris, and any contaminants.
- **HOSE MATERIAL:** Check that the hose material is compatible with the fluid being pumped. Consult your Graco distributor for available hose materials.
- **FASTENERS:** Check that all fasteners are properly tightened.
- **LEAKS:** Check the connections on the fluid inlet and outlet to be sure there are no leaks. Check the front cover for signs of leaks from the front cover gasket.
- **COVERS:** Verify that the front cover and motor fan cover are in place before starting the pump.

Initial Configuration (AC with VFD)

For initial setup, review at least the following menus to configure the system to suit your particular needs. See your VFD manual for detailed information about each menu option and about default settings.

1. VFD Parameter P103 controls the maximum frequency (the top end of manual speed) of running your pump. This setting is NOT your operating frequency. It is the maximum limit of operating frequency.
2. VFD Parameter P108 controls motor overload. Set so that the VFD cannot supply more current to the motor than it can handle. The formula for the set value is:
 $X = \text{Motor current rating} \times 100 / \text{VFD output current rating}$
3. VFD Parameter P171 controls the absolute current limit. It is set to allow for momentary spikes in current above the limit set in P108. A spike occurs, for example, when the roller passes over the double hose section. This parameter is usually set for 2 to 3 times the value on menu P108, which was calculated in the previous step.
4. VFD Parameter P112 controls the direction of motor rotation. See [Reverse Motor Direction, page 32](#), to change.

5. VFD Parameter P104 (optional) controls the rate at which the motor will ramp up to the set speed
6. VFD Parameter P166 (optional) allows for adjustment to the noise that the motor creates. Each setting changes the tone.

Initial Configuration (BLDC with Graco Motor Control)

For initial setup, review at least the following menus to configure the system to suit your particular needs. See the reference table in [Setup Mode, page 37](#), for detailed information about each menu option and about default settings.

1. To clear the WSCP alarm, go to Set Pump Size (menu G401). Select the correct pump size. Once set, this menu is no longer visible.
2. Set the desired flow units on menu G201.
3. If Batch mode is desired, set menu G200 to 1 and set the batch flow rate in menu G247.
4. Go to the Set Maintenance Intervals (menus G230, G231, and 232). Use these menus to enable the maintenance counter and set the number of cycles (in millions) for each of three maintenance intervals. For example, a user could set the maintenance interval for the hose on menu 230, for the roller on menu 231, and for the main drive on menu 232.
5. Go to Enable Max Power Mode (menu G204). Use this menu to indicate whether the current limit is 12A or 16A, and to enable or disable Max Power Mode (see explanation in the reference table in [Setup Mode, page 37](#)).
6. Go to Set Pump Direction (menu G211). Use this menu to indicate whether the pump should rotate clockwise (0) or counter-clockwise (1).
7. Go to Set Leak Detection Type (menu G206). Use this menu to indicate how the system should respond if a leak is detected.
8. Follow the calibration procedure and set the pump K-Factor (menu G203). Use this procedure and menu to adjust the pump displacement per cycle to match the actual performance of your pump.
9. Return to Run Mode and enter your desired operating setpoint.

Start the Pump

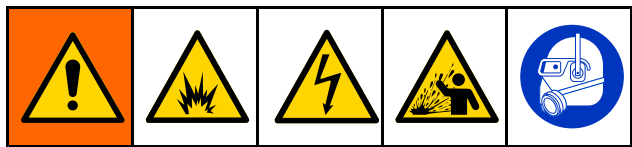

1. Be sure the pump is properly grounded. See [Grounding, page 16](#).
2. Verify that all items in the [Pre-Start Checklist, page 28](#), are completed.
3. Fully open all valves on the fluid inlet and outlet lines. This is a positive displacement pump and will continue to build pressure, even against a closed valve.
4. Disengage the motor lockout at the power supply.
5. Start the motor.
6. Run the pump slowly, gradually increasing speed until the desired outlet pressure is achieved and the pump and hoses are fully primed.

- Run the pump as slowly as possible to achieve the desired results. Measure the fluid inlet and outlet pressure to verify that the pump is operating at the designed pressure point.
- **Do not** operate the pump motor above the full load amperage stamped on the motor nameplate. The pump can be operated at low motor amperage.
- Keep the pump fluid inlet and outlet open and free of obstructions.
- As back pressure increases, flow rate may decrease, especially for low-viscosity fluids at low cycle rates. If flow is lower than required, reduce the back pressure, increase the cycle rate, or reverse the direction of flow.

Running the Pump

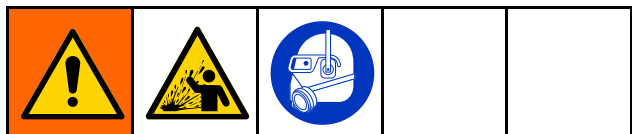

Ensure that the hose material and the lubricant are compatible with the pumped fluid. Failure to do so may cause injury or premature hose failure.

NOTICE

Never throttle the pump, whether on the fluid inlet or outlet side. This will cause damage. Do not operate the pump against a closed inlet or outlet valve.

Dry Running

The pump can run dry without damaging the pump. However, pumped fluid normally provides a cooling effect to both the hose and the hose lubricant. Continuous dry running may reduce hose life.

Operating in Low Temperatures

NOTICE

Never operate the pump if the fluid inside the hose is frozen. This will cause serious damage to the pump.

If operating the pump at low temperatures, ensure that the fluid being pumped does not freeze inside the hose, especially during long periods of idleness. Do not start the pump if the fluid inside the hose is frozen. Ensure that the inlet line, the outlet line, and the pump housing are heat-taped and insulated so freezing does not occur.

BLDC Flow Calibration Procedure

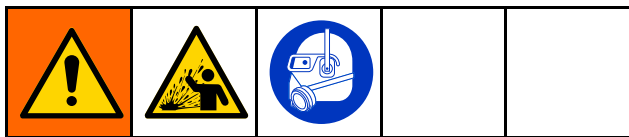

NOTE: This procedure applies to systems using the Graco Motor Control.

1. The system is in Flow Control Mode. Menu G200 = 0.
2. The pump is primed. See [Start the Pump, page 29](#).
3. Set the desired flow rate from the Run Mode screen.
4. Go to the View or Reset Volume menu (G101).
5. Press and hold  to clear the volume total.
6. With a container ready to catch the dispensed material, start the pump.
7. Run the pump for the desired calibration time. Note that a large volume is more accurate, at least 10 or more cycles.
8. Stop the pump.
9. Record the volume (V_{batch}) shown on the G101 menu.
10. Measure the volume (V_{actual}) that was actually captured during the dispense. Be sure to measure in the same units being displayed. See [Set Flow Units \(menu G201\)](#) to change units.
11. See [Set the Pump K-Factor \(menu G203\)](#). Write down the K-factor currently displayed ($K\text{-Factor}_{\text{old}}$).
12. Calculate the new K-Factor using the following formula:

$$K\text{-Factor}_{\text{new}} = K\text{-Factor}_{\text{old}} \times (V_{\text{actual}} / V_{\text{batch}})$$
13. Set the G203 menu to $K\text{-Factor}_{\text{new}}$.

BLDC Batch Calibration Procedure

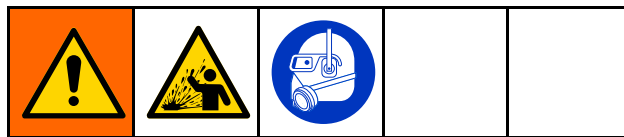

NOTE: This procedure applies to systems using the Graco Motor Control.

1. The system is in Batch Control Mode. Menu G200 = 1.
2. The pump is primed. See [Start the Pump, page 29](#).
3. Set the desired batch flow rate on the Batch Mode Target Flow menu G247.
4. Set the desired batch volume (V_{batch}) on the Run Mode screen. Note that a large volume is more accurate, at least 10 or more cycles. See [Set Flow Units \(menu G201\)](#) to change units.
5. With a container ready to catch the dispensed material, start the pump.
6. The pump will run for the set batch volume.
7. After the pump has stopped, measure the volume (V_{actual}) that was actually captured during the dispense. Be sure to measure in the same units as the batch setpoint.
8. See [Set the Pump K-Factor \(menu G203\)](#). Write down the K-factor currently displayed ($K\text{-Factor}_{\text{old}}$).
9. Calculate the new K-Factor using the following formula:

$$K\text{-Factor}_{\text{new}} = K\text{-Factor}_{\text{old}} \times (V_{\text{actual}} / V_{\text{batch}})$$
10. Set the G203 menu to $K\text{-Factor}_{\text{new}}$.

Pressure Relief Procedure



Follow the Pressure Relief Procedure whenever you see this symbol.

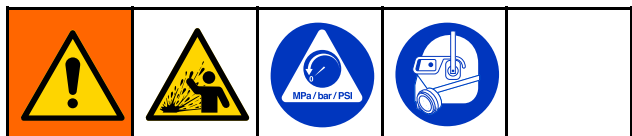

This equipment stays pressurized until pressure is relieved manually. To help prevent serious injury from pressurized fluid, such as splashing in the eyes or on skin, follow the Pressure Relief Procedure when you stop pumping and before you clean, check, or service the equipment.

1. Remove power from the system.
2. Open the dispensing valve, if used.
3. Open the fluid drain valve to relieve fluid pressure. Have a container ready to catch the drainage.

Shutdown

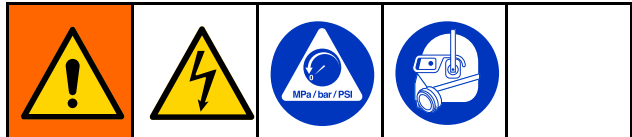

For short shutdowns (overnight, over the weekend), follow the [Pressure Relief Procedure, page 31](#).

To stop the pump for 3 to 30 days, use the following procedure. If the pump will be out of service for more than 30 days, see [Storage, page 31](#).

1. Follow the [Pressure Relief Procedure, page 31](#).
2. Flush the fluid lines and pump to remove solids that may accumulate in the line or hose. See [Flushing, page 45](#).
3. Follow the [Pressure Relief Procedure, page 31](#).
4. Shut off the motor and remove all power.
5. Isolate any flushing fluid connections.
6. Disconnect the fluid inlet and outlet hoses (or close the valves if present in your system).

NOTE: For maximum hose life, see [Storage, page 31](#), for instructions on how to relieve the pressure on the hose.

Storage

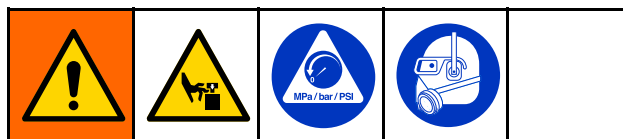

Follow this procedure to store the pump for more than 30 days.

1. Follow all steps in [Shutdown, page 31](#).
2. Remove the front cover drain plug to drain all lubricant from the pump, then remove the cover.
3. The roller must be moved to eliminate compression on the hose (14). Follow the directions for your pump to move the roller between the 4- and 8-o'clock positions while pulling on the hose at the bottom until the hose is free from the roller.
 - a. **AC Models:** Loosen the screws and remove the motor fan cover. Turn the fan by hand to move the roller.

NOTE: Low RPM pumps and high ratio gearboxes may require many turns of the motor fan to move the roller.
 - b. **BLDC Models:**
 - i. Insert the shaft socket into the back of the gearbox.
 - ii. Use a socket wrench to move the roller.
4. **AC Models:** Replace the fan cover. **BLDC Models:** Remove the socket from the gearbox.
5. Store the pump in a clean, dry area that is free from direct sunlight and extremes in temperature.

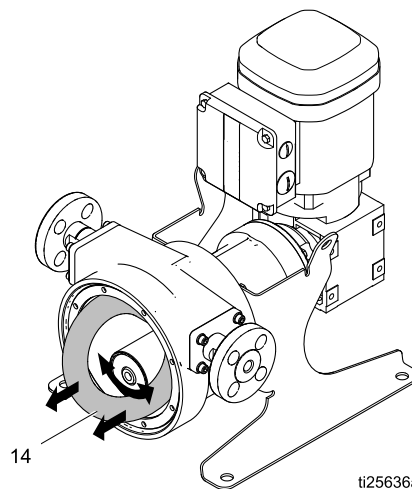

Figure 14 Hose Position for Storage

VFD Operation (AC Models)

VFD Control Panel

NOTE: For complete information about the VFD, see the manufacturer's instructions supplied with the VFD.

- The control panel display shows the status of the motor. It also shows the direction of motor rotation: FWD (forward) or REV (reverse).
- The green RUN key starts the motor.
- The red STOP key stops the motor.
- Use the arrow keys to speed up or slow down the motor.
- The blue R/F key changes the motor rotation (see [Reverse Motor Direction, page 32](#)).
- The blue M key accesses the VFD menu. See the manufacturer's instructions for menu descriptions and information.

NOTE: If the M key is pressed, use the arrow keys to scroll through the VFD menu.



Figure 15 VFD Control Panel

Factory Settings

VFD settings are preset at the factory for most applications. See [Initial Configuration \(AC with VFD\), page 28](#), to change the default settings as needed to suit your needs.

Reverse Motor Direction

NOTE: VFD Parameter P112 controls the direction of motor rotation. The VFD is shipped with the rotation set to forward as a default.

1. Verify which way the roller is moving. See [Fluid Connections, page 14](#).
2. Press the M key to access the VFD menu.
3. Scroll to **P112**, using the arrow keys.
4. Press the M key again.
5. **00** will display on the screen. Use the arrow keys to set the display to **01**. This allows both forward and reverse rotation.
6. Press the M key to enter the setting. The screen will display STOP or the last frequency setting.

NOTE: To use this feature when operating the pump, press the R/F key, then the M key. The drive will slow and the motor will reverse direction. Press the RUN key and check that the roller is moving in the opposite direction.

Adjust the Speed

Use the arrow keys on the VFD control panel to increase or decrease the motor speed.

Graco Motor Control Operation (BLDC Models)

Display

The Graco Motor Control provides the interface for users to enter selections and view information related to setup and operation.

Membrane keys are used to input numerical data, enter the setup screens, and select or input setup values.

NOTICE

To prevent damage to the softkey buttons, do not press the buttons with sharp objects such as pens, plastic cards, or fingernails.

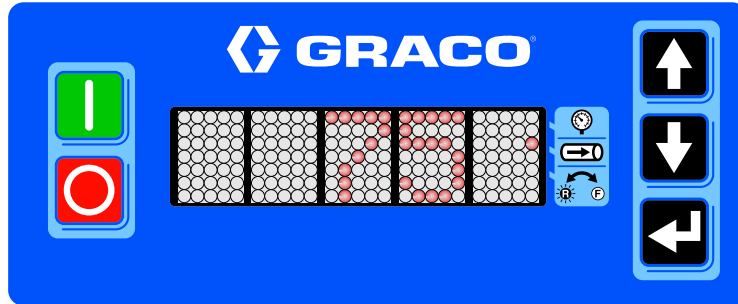

Membrane Key	Action
	<p>Manual Control: Press to start the pump.</p> <p>Remote Control (PLC): Press to clear alarm EBG0. The remote signal will then start the pump again.</p>
	<p>Manual Control: Press to stop the pump. If this button is pressed a second time (while the pump is decelerating), the pump will stop immediately.</p> <p>Remote Control (PLC): The remote signal normally stops the pump. Press to override the remote control and set the EBG0 alarm.</p>
	Press to navigate the setup menu codes, to adjust the digits in a numerical entry, or to scroll to the desired setpoint.
	<p>Function varies by mode and current activity.</p> <ul style="list-style-type: none"> • Run Mode: Press to edit the setpoint. Press again to accept the entry. Also press to acknowledge an event code. When not editing, press and hold for 2 seconds to enter Setup Mode • Setup Mode: Press to enter a selection or to accept the current value of an entry. When not editing, press and hold for 2 seconds to return to Run Mode.
	Pressure Mode: LED next to mode will blink when pressure mode is selected, and in standby. LED will light when flow mode is selected and in standby, or pressure mode is running.
	Flow Mode: LED next to mode will blink when flow mode is selected, and in standby. LED will light when pressure mode is selected and in standby, or flow mode is running.
	Pump Direction: LED extinguished for forward rotation; LED lit for reverse rotation

Graco Motor Control Software Overview

The Graco Motor Control has two possible control methods: Flow Control and Batch Dispense. See



Table 6 for an explanation of each method. Table 7 explains some key Graco Motor Control features.

Table 6 Control Methods

Control Method	Details
Flow Control	<ul style="list-style-type: none"> • Controls the pump flow by increasing or decreasing the speed of the motor. • Shows the current pump flow in user selectable units (G201). • Maximum acceleration and deceleration are limited by user setting.
Batch Dispense	<ul style="list-style-type: none"> • Dispenses a user specified amount of material. <ul style="list-style-type: none"> – Shows the volume remaining to be dispensed in user selectable units. – Dispensing can be interrupted and resumed if the dispense amount is not changed. – Maximum number of units which can be dispensed will vary depending on viscosity of material and pump speed. • Batches can be repeated on a timed cycle. <ul style="list-style-type: none"> – Pump must not be in standby or stopped by an event. – Dispense amount is not changed. – After a batch completes, the timer is displayed showing time remaining until next batch begins. <ul style="list-style-type: none"> ◆ XXh: hours displayed (>35999 seconds remain) ◆ XhXX: hours and minutes displayed (600-35999 seconds remain) ◆ XmXX: minutes and seconds displayed (1-599 seconds remain) • Dispense flow rate is specified by the user. • Pump K-Factor is calibrated by external means and specified in user settings. • Maximum acceleration and deceleration is limited by user setting. • Stopping the pump manually before a batch completes will cause an EBC0 event code to be displayed which must be manually acknowledged before the batch can be resumed.

Table 7 Graco Motor Control Key Features

Control Feature	Details
Leak Detection	<ul style="list-style-type: none"> • Receives a signal from the pump leak detector informing the controller of a hose rupture. • The controller either warns or stops the pump, depending on a user setting. • An event code is displayed.
Cycle Counting	<ul style="list-style-type: none"> • The controller tracks pump cycles and informs the user of any scheduled maintenance intervals. • User selects the number of cycles for the maintenance interval (i.e. hose replacement).
Batch Counter	<ul style="list-style-type: none"> • The controller tracks the dispensed pump volume. <ul style="list-style-type: none"> – The counter can be reset by the user.
Batch Timer	<ul style="list-style-type: none"> • The controller starts batches at a time interval defined by G248. <ul style="list-style-type: none"> – Time value is user defined. – Starts pump when timer expires. – Time value is set from start of current batch to start of next batch. – A value that is shorter than the completion time of a currently-defined batch will result in unintended results, but no error message is generated.
HoseGuard	<ul style="list-style-type: none"> • This can be used to stop the pump if the outlet pressure spikes. • Outlet pressure spike sensitivity is variable and adjustable by the user. • Displays an FCDH event code until HoseGuard is calibrated. HoseGuard is not functional until calibration is completed. • HoseGuard calibration: <ul style="list-style-type: none"> – Enable HoseGuard in menu G214. – Have the pump connected to a product source. – Have the outlet in normal operational configuration without any additional restriction. – Start the pump. When the pump reaches full operational speed and makes one complete pump revolution, calibration will be complete. • HoseGuard calibration information is retained until G214 is changed to disable HoseGuard, pump direction is reversed, or input power to the Graco Motor Control is turned off.
Max Power Mode	<ul style="list-style-type: none"> • This mode allows the user to disable the over current and motor temperature faults. The result is a reduction in pump performance which is dependent on the limiting factor. • The system alerts the user that the pump is running at reduced performance and the reason for the reduction. • Motor Temperature Scaling <ul style="list-style-type: none"> – The Graco Motor Control limits power to the motor when the motor winding temperature is too hot. <ul style="list-style-type: none"> ◆ Limit Start – 120°C (248°F) ◆ Limit Stop (Full Shutdown) – 150°C (302°F)





Control Feature	Details
Input Current (Power) Limit	<ul style="list-style-type: none"> • The Graco Motor Control limits power to the motor depending on the voltage and current available from line power. <ul style="list-style-type: none"> – 12A (120/240V, 15A circuit) (default) – 16A (120/240V, 20A circuit)
PLC Control	<ul style="list-style-type: none"> • Input Hardware: <ul style="list-style-type: none"> – Digital Input (Start/Stop) — Sinking <ul style="list-style-type: none"> ◆ 12VDC (internally pulled-up) logic ◆ Logic Low (asserted/closed) < 4VDC ◆ Logic High (released/open) > 6VDC ◆ 35VDC tolerant – Analog Input (Flow Signal) <ul style="list-style-type: none"> ◆ 4-20 mA logic ◆ 250 ohm impedance ◆ 35VDC (2W) tolerant • Stop Only (Manual Start) <ul style="list-style-type: none"> – Start/Stop signal must be asserted (pulled low) to run the pump. – The user manually starts the system. – The stop button or Start/Stop signal will stop the pump. • Start/Stop (Full Remote) <ul style="list-style-type: none"> – The falling edge of the Start/Stop signal will start the pump. The Start/Stop signal must remain asserted (pulled low) to run the pump. – Pressing the local Stop button disables the system until the local Start button is pressed. • Full Control (Both Start/Stop and Flow) <ul style="list-style-type: none"> – The falling edge of the Start/Stop signal will start the pump. The Start/Stop signal must remain asserted (pulled low) to run the pump. – Pressing the local Stop button disables the system until the local Start button is pressed. – Analog input is used for pump flow. – Input range can be configured in user settings (see menus G212, G213, G240, and G241) – Analog Control Mode: <ul style="list-style-type: none"> ◆ Flow Control: Target Flow Rate ◆ Batch Dispense: Dispense Flow Rate • Override Stop: When operating in Start/Stop Control or Full Control,  can be used to override the external signal and stop the pump. This override will cause the EBG0 event to be set. Press  to acknowledge all events. Then press  to clear the EBG0 event and re-enable external control. The controller will then look for a falling signal edge to signal a Start.

Operation Modes

The Graco Motor Control has two operation modes: Run Mode and Setup Mode.



Run Mode

When in Run Mode, the Graco Motor Control displays the current flow rate (flow mode) or volume remaining (batch mode).

To adjust the setpoint, press . Use  and  to scroll to the desired value. Press  to accept your entry.

If your system is using External Full Control (menu G209 is set to 3), the setpoint is externally controlled. The setpoint may be viewed, but it cannot be adjusted.

Setup Mode





Press  for 2 seconds to enter Setup Mode. If a password has been set, enter it to proceed. The Setup Mode screens timeout (return to the Run Screen) after 60 seconds without a button press. Each menu in Setup times out after 30 seconds unless the user presses .

NOTE: Not entering a password or entering an incorrect password will still allow accessing 1xx and 3xx menus.



The Setup Mode is organized into four broad categories:

- 100s: Maintenance
- 200s: Setup (password protected)
- 300s: Diagnostics (displays system values only; not operator changeable)
- 400s: Advanced (password protected)

The reference table in this section provides a description of each Setup Mode menu option.

1. Use  and  to scroll to the desired setup menu code.
2. Press  to make an entry or selection for that code. For example, scroll to setup menu code G210, which is used to set a password. Press .

Some Setup Mode menus require the user to enter a number.

1. Use  and  to set each digit of the number.
2. Press  on the last digit to return to the setup menu code options.

Other Setup Menu options require the user to scroll through and select the number that corresponds to the desired selection. The table shows the content that corresponds to each scrolled number in a menu.











- Use  and  to scroll to the desired number.
- Press  on the selected number. For example, in menu G206, scroll to the number 2 and press  if you want your system to issue an alarm and stop the pump if it detects a leak.

Table 8 Available Menus with Descriptions

Setup Mode	
G100	Displays the last 20 system event codes. Use  and  to scroll through the event codes.
VIEW EVENTS	
G101	Displays the batch volume that has been dispensed. This value is in the Flow Units selected in menu G201. Changing G201 will cause the value in G101 to change to the new flow unit. <ul style="list-style-type: none"> • Hold  for 2 seconds to reset the counter. • Units are user selectable. See Set Flow Units (menu G201).
VIEW or RESET BATCH VOLUME	
G102	Displays the total number of pump cycles for the life of the pump. <ul style="list-style-type: none"> • Displays in cycles (XXXXX), thousands of cycles (XXXXK), or millions of cycles (XXXXM).
VIEW LIFE TOTAL	
G130	Displays the number of pump cycles since the last maintenance. <ul style="list-style-type: none"> • Hold  for 2 seconds to reset the counter. • Displays in cycles (XXXXX), thousands of cycles (XXXXK), or millions of cycles (XXXXM).
VIEW MAINTENANCE COUNTER 1	
G131	Displays the number of pump cycles since the last maintenance. <ul style="list-style-type: none"> • Hold  for 2 seconds to reset the counter. • Displays in cycles (XXXXX), thousands of cycles (XXXXK), or millions of cycles (XXXXM).
VIEW MAINTENANCE COUNTER 2	
G132	Displays the number of pump cycles since the last maintenance. <ul style="list-style-type: none"> • Hold  for 2 seconds to reset the counter. • Displays in cycles (XXXXX), thousands of cycles (XXXXK), or millions of cycles (XXXXM).
VIEW MAINTENANCE COUNTER 3	
G200	Set the pump control mode. The pump must be stopped to edit this field. 0 = Flow Control (default) 1 = Batch Control
SET CONTROL MODE	
G201	Set the display flow units, which also sets the internal volume units. 0 = cycles per minute (cpm, default) 1 = gallons per minute (gpm) 2 = liters per minute (lpm) 3 = gallons per hour (gph) 4 = liter per hour (lph)
SET FLOW UNITS	

G203	SET PUMP K-FACTOR	Set the pump displacement per cycle. Follow the BLDC Flow Calibration Procedure, page 30 , or the BLDC Batch Calibration Procedure, page 30 , to obtain the information needed for this menu. Units are always cc/cycle. The menu is visible only if flow units (menu G201) are set to gpm (1), lpm (2), gph (3), or lph (4), not cpm (0) . The pump must be stopped to edit this field.																				
• Range and default vary by pump size. Values in table are in cc per cycle.:																						
		<table border="1"> <thead> <tr> <th>Pump</th> <th>Minimum</th> <th>Maximum</th> <th>Default</th> </tr> </thead> <tbody> <tr> <td>ST10</td> <td>3</td> <td>39</td> <td>26</td> </tr> <tr> <td>ST23</td> <td>19</td> <td>287</td> <td>191</td> </tr> <tr> <td>ST26</td> <td>42</td> <td>624</td> <td>416</td> </tr> <tr> <td>ST30</td> <td>66</td> <td>995</td> <td>663</td> </tr> </tbody> </table>	Pump	Minimum	Maximum	Default	ST10	3	39	26	ST23	19	287	191	ST26	42	624	416	ST30	66	995	663
Pump	Minimum	Maximum	Default																			
ST10	3	39	26																			
ST23	19	287	191																			
ST26	42	624	416																			
ST30	66	995	663																			
G204	ENABLE MAX POWER MODE	Menu is not visible if G214 >0. Enable this setting to change the Over Current and Motor Temperature events from Alarms to Deviations, which allows the pump to keep running with reduced performance (may not maintain flow setpoint). The pump must be stopped to edit this field. 0 = Disabled (Default) 1 = Enabled																				
G205	INPUT CURRENT LIMIT	Set the maximum input current allowed. The pump must be stopped to edit this field. 0 = 12A (Default) 1 = 16A																				
G206	SET LEAK DETECTION TYPE	Set the desired system response to a leak detection. 0 = Disabled or leak sensor not installed (Default) 1 = Deviation (system alerts the user but does not stop the pump) 2 = Alarm (system alerts the user and stops the pump).																				
G207	SET MAXIMUM ACCELERATION	Set the time in seconds to maximum speed (90 cpm) from stop.																				
		<ul style="list-style-type: none"> • Range is 1-300 seconds. • Default is 3 seconds. 																				
G208	SET MAXIMUM DECELERATION	Set the time in seconds to stop from the maximum speed (90 cpm).																				
		<ul style="list-style-type: none"> • Range is 1-300 seconds. • Default is 1 second. 																				
G209	CONFIGURE EXTERNAL CONTROL	Configure the external control inputs. The pump must be stopped to edit this field. 0 = Disabled (Default) 1 = Stop Only (Manual Start) 2 = Start/Stop (Full Remote) 3 = Full Control (Both Start/Stop and Flow)																				
G210	SET or DISABLE PASSWORD	Set the setup lockout password. Users who do not know the password will be able to change information in the G100s (Maintenance) and G300s (Diagnostics), but will be locked out from the G200s (Setup) and G400s (Advanced).																				
		<ul style="list-style-type: none"> • Range is 1-99999. • Enter 0 to disable the password. • Enter 99999 to reveal the Advanced menu (menus G40x). • Default is 0. 																				

G211	Set the pump rotation direction. The pump must be stopped to edit this field. 0 = Clockwise (default) 1 = Counterclockwise
SET PUMP DIRECTION	
G212	Set the analog input level that corresponds to the minimum allowable control setpoint (menus G240 or G245). This menu is visible only if external controls (menu G209) are configured for full control (3).
SET 4–20 ANALOG LOW INPUT	<ul style="list-style-type: none"> • Range is 4.0 – 20.0 mA. • Default is 4.0 mA.
G213	Set the analog input level that corresponds to the maximum allowable control setpoint (menus G241 or G246). This menu is visible only if external controls (menu G209) are configured for full control (3).
SET 4–20 ANALOG HIGH INPUT	<ul style="list-style-type: none"> • Range is 4.0 – 20.0 mA. • Default is 20 mA.
G214	Menu is not visible if G204 is set to 1. If using hoseguard, select the most sensitive setting that will allow the system to operate under normal operating conditions. Some configuration and product combinations may cause pressure spikes during normal operation that will prevent the use of hoseguard.
HOSEGUARD	<ul style="list-style-type: none"> • Range is 0 — 5 • Default is 0 (disable hoseguard) • 1 (most sensitive) — 5 (least sensitive)
G230	Set the desired maintenance interval in millions of cycles.
SET MAINTENANCE INTERVAL 1	<ul style="list-style-type: none"> • Range is 0.1 — 99.9 million cycles. • Enter 0 to disable the maintenance counter. • Default is 0.
G231	Set the desired maintenance interval in millions of cycles.
SET MAINTENANCE INTERVAL 2	<ul style="list-style-type: none"> • Range is 0.1 — 99.9 million cycles. • Enter 0 to disable the maintenance counter. • Default is 0.
G232	Set the desired maintenance interval in millions of cycles.
SET MAINTENANCE INTERVAL 3	<ul style="list-style-type: none"> • Range is 0.1 — 99.9 million cycles. • Enter 0 to disable the maintenance counter. • Default is 0.
G240	Set the lowest selectable flow setpoint.
SET MINIMUM FLOW SETPOINT	<ul style="list-style-type: none"> • Units are user selectable. See Set Flow Units (menu G201). • Menu is visible only if Control Mode (menu G200) is set to flow (0) or if External Control (menu G209) is set to full control (3). • Range is 0–90 cycles per minute. • Default is 0. <p>Example: If you want the system to dispense at least 5 lpm, set the control mode to flow control (menu G200), and the flow units to liters (menu G201). Set this menu to 5. Users will not be able to enter a minimum setpoint lower than 5 lpm.</p>

G241	Set the highest selectable flow setpoint.
SET MAXIMUM FLOW SETPOINT	<ul style="list-style-type: none"> • Units are user selectable. See Set Flow Units (menu G201). • Menu is visible only if Control Mode (menu G200) is set to flow (0) or if External Control (menu G209) is set to full control (3). • Range is 0–90 cycles per minute. • Default is 90. <p>Example: If you want the system to dispense no more than 10 lpm, set the control mode to flow control (menu G200) and set the flow units to liters (menu G201). Set this menu to 10. Users will not be able to enter a maximum setpoint higher than 10 lpm.</p>
G245	Set the lowest selectable volume setpoint.
SET MINIMUM VOLUME SETPOINT	<ul style="list-style-type: none"> • Units are user selectable. See Set Flow Units (menu G201). • Menu is visible only if Control Mode (menu G200) is set to batch (1). • Range is 0–9999 cycles. • Default is 0. <p>Example: If you want the system to dispense at least 15 gallons in each batch, set the control mode to batch control (menu G200) and set the flow units to gallons (menu G201). Set this menu to 15. Users will not be able to enter a minimum setpoint lower than 15 gallons.</p>
G246	Set the highest selectable volume setpoint.
SET MAXIMUM VOLUME SETPOINT	<ul style="list-style-type: none"> • Units are user selectable. See Set Flow Units (menu G201). • Menu is visible only if Control Mode (menu G200) is set to batch (1). • Range is 0–9999 cycles. • Default is 9999. <p>Example: If you want the system to dispense no more than 50 gallons in each batch, set the control mode to batch control (menu G200) and set the flow units to gallons (menu G201). Set this menu to 50. Users will not be able to enter a maximum setpoint higher than 50 gallons.</p>
G247	Set the flow rate to use while in batch control mode.
BATCH MODE TARGET FLOW	<ul style="list-style-type: none"> • Units are user selectable. See Set Flow Units (menu G201). • Menu is visible only if Control Mode (menu G200) is set to batch (1). • This menu <i>is not</i> editable if external controls (menu G209) are configured for full control (3). The system displays the setpoint as set by the analog input. • Range is 1–90 cycles per minute. • Default is 10.
G248	Menu is only visible if G200 is set to 1. Set the number of seconds to elapse from the start of a batch until the next batch will be started automatically. When the interval timer counts down to zero, it will once again return to the entered value, begin counting down, and the batch is started. If the current batch has not completed by the time the timer reaches zero, the next batch will not begin until the next time the timer counts down to zero. The pump must be stopped to edit this field.
BATCH START INTERVAL	<ul style="list-style-type: none"> • Range is 0 — 99999 • Default is 0 (disable)

Graco Motor Control Operation (BLDC Models)

G300	Display the pump flow rate
VIEW FLOW RATE	<ul style="list-style-type: none"> • User cannot edit. • Units are user selectable. See Set Flow Units (menu G201).
G302	Displays the BUS voltage in V.
VIEW BUS VOLTAGE	<ul style="list-style-type: none"> • User cannot edit.
G303	Displays the RMS motor voltage in V.
VIEW MOTOR VOLTAGE	<ul style="list-style-type: none"> • User cannot edit.
G304	Displays the RMS motor current in A.
VIEW MOTOR CURRENT	<ul style="list-style-type: none"> • User cannot edit.
G305	Displays the motor power in W.
VIEW MOTOR POWER	<ul style="list-style-type: none"> • User cannot edit.
G306	Displays the IGBT temperature in °C.
VIEW CONTROLLER TEMPERATURE	<ul style="list-style-type: none"> • User cannot edit.
G307	Displays the motor temperature in °C.
VIEW MOTOR TEMPERATURE	<ul style="list-style-type: none"> • User cannot edit.
G308	Displays the software configuration.
VIEW SOFTWARE VERSION & SERIAL NUMBER	<ul style="list-style-type: none"> • User cannot edit. • Information displayed includes software part number, software version, and serial number.
G309	Displays the leak sensor input status.
VIEW LEAK SENSOR INPUT	<ul style="list-style-type: none"> • User cannot edit. • 0 = No Leak Detected • 1 = Leak Detected, or leak sensor not installed
G310	Displays the run/stop input status.
VIEW RUN/STOP INPUT	<ul style="list-style-type: none"> • User cannot edit. • 0 = Stop • 1 = Run
G311	Displays the 4-20 mA analog input in mA.
VIEW 4-20 ANALOG READING	<ul style="list-style-type: none"> • User cannot edit.
G312	Displays the time (in seconds) remaining until the next batch will begin.
BATCH INTERVAL TIMER	<ul style="list-style-type: none"> • User cannot edit.

<p>G400</p>	<p>Resets all settings to factory defaults. This menu appears only if the password is set to 99999 on menu G210. When “RESET” appears on the display, press and</p>
<p>RESET TO FACTORY DEFAULT</p>	<p>hold  for 2 seconds to reset the system.</p>
<p>G401</p>	<p>Set the size of the pump/motor. This menu is visible when 0 (none) is selected. The pump must be stopped to edit this menu. When a selection is set, the menu is no longer visible. This menu appears only if the password is set to 99999 on menu G210.</p>
<p>SET PUMP SIZE</p>	<p>0 = None (default) 1 = ST10 (SEW gearbox) 2 = ST23 (SEW gearbox) 3 = ST26 (SEW gearbox) 4 = ST30 (SEW gearbox) 5 = ST10 (Nord gearbox) 6 = ST23 (Nord gearbox) 7 = ST26 (Nord gearbox) 8 = ST30 (Nord gearbox)</p>

Graco Motor Control Menu Quick Reference

G100 (View Events) Displays the last 20 system event codes.
G101 (View or Reset Batch Volume) Displays the batch volume that has been dispensed.
G102 (View Life Total) Displays the total number of pump cycles for the life of the pump.
G130–G132 (View Maintenance Counters 1, 2, 3) Displays the number of pump cycles since the last maintenance.
G200 (Set Control Mode) 0 = Flow Control (default) 1 = Batch Control
G201 (Set Flow Units) 0 = cycles per minute (cpm), default 1 = gallons per minute (gpm) 2 = liters per minute (lpm) 3 = gallons per hour (gph) 4 = liters per hour (lph)
G203 (Set Pump K-Factor) Range and default. ST10: 3–39 cc/cycle; default 26 ST23: 19–287 cc/cycle; default 191 ST26: 42–624 cc/cycle; default 416 ST30: 66–995 cc/cycle; default 663
G204 (Enable Max Power) 0 = Disabled (Default) 1 = Enabled
G205 (Input Current Limit) 0 = 12A (Default) 1 = 16A
G206 (Set Leak Detection Type) 0 = Disabled or leak sensor not installed (Default) 1 = Deviation 2 = Alarm
G207 (Set Maximum Acceleration) Range: 1–300 seconds Default: 3 seconds
G208 (Set Maximum Deceleration) Range: 1–300 seconds Default: 1 second
G209 (Configure External Control) 0 = Disabled (Default) 1 = Stop Only (Manual Start) 2 = Start/Stop (Full Remote) 3 = Full Control (Both Start/Stop and Flow)
G210 (Set or Disable Password) Range: 1–99999 99999 = display G40x menus Default: 0
G211 (Set Pump Direction) 0 = Clockwise (default) 1 = Counterclockwise
G212 (Set 4–20 Analog Low Input) Range: 4.0 – 20.0 mA Default: 4.0 mA
G213 (Set 4–20 Analog High Input) Range: 4.0 – 20.0 mA Default: 20 mA

G214 (Hoseguard) Range: 0 – 5 Default: 0
G230–G232 (Set Maintenance Counters 1, 2, 3) Range: 0.1 – 99.9 million cycles Default: 0
G240 (Set Minimum Flow Setpoint) Range: 0–90 cpm Default: 0
G241 (Set Maximum Flow Setpoint) Range: 0–90 cpm Default: 90
G245 (Set Minimum Volume Setpoint) Range: 0–9999 cycles Default: 0
G246 (Set Maximum Volume Setpoint) Range: 0–9999 cycles Default: 9999
G247 (Batch Mode Target Flow) Range: 1–90 cpm Default: 10
G248 (Batch Start Interval) Range: 0–99999 Default: 0
G300 (View Flow Rate) Displays the pump flow rate.
G302 (View BUS Voltage) Displays the BUS voltage in V.
G303 (View Motor Voltage) Displays the RMS motor voltage in V.
G304 (View Motor Current) Displays the RMS motor current in A.
G305 (View Motor Power) Displays the motor power in W.
G306 (View Controller Temperature) Displays the IGBT temperature in °C.
G307 (View Motor Temperature) Displays the motor temperature in °C.
G308 (View Software Information) Displays the software version and serial number.
G309 (View Leak Sensor Input) 0 = No Leak Detected 1 = Leak Detected, or leak sensor not installed
G310 (View Run/Stop Input) 0 = Stop 1 = Run
G311 (View 4–20 Analog Reading) Displays the 4–20 mA analog input in mA.
G312 (Batch Interval Timer) Range: 0–99999 seconds
G400 (Reset to Factory Defaults) Resets all settings to factory defaults.
G401 (Set Pump Size) 0 = None (default) 1 = ST10 SEW 2 = ST23 SEW 3 = ST26 SEW 4 = ST30 SEW 5 = ST10 Nord 6 = ST23 Nord 7 = ST26 Nord 8 = ST30 Nord

Maintenance

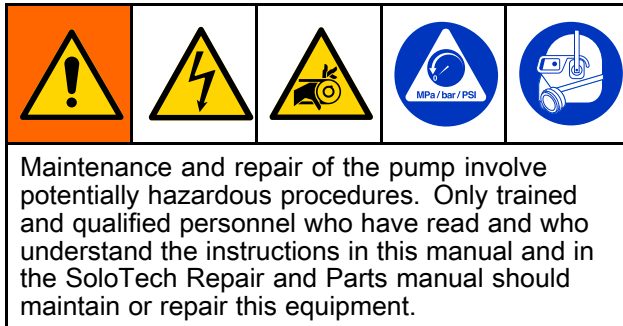

Preventive Maintenance Schedule

Establish a preventive maintenance schedule based on the pump's service history. Scheduled maintenance is especially important to prevent spills or leakage due to hose failure.

Flushing

- Flush before changing fluids, before fluid can dry in the equipment, at the end of the day, before storing, and before repairing equipment.
 - Flush at the lowest pressure possible. Check connectors for leaks and tighten as necessary.
 - Flush with a fluid that is compatible with the fluid being dispensed and the equipment wetted parts.
1. **Option 1:** Using the flushing material, operate the pump in the usual manner.
 2. **Option 2:** Follow steps 1 — 3 in [Storage, page 31](#), to pull out the hose so that it is not being compressed by the roller. Push water or solvent through.

Pump Bearing Lubrication

Inspect the pump and re-grease the bearings if you suspect that the original grease was contaminated by a grease seal failure. The pump must be disassembled. See *Install the Seals* in the Repair/Parts manual.

Hose Lubrication

The pump requires lubrication of the hose. The lubrication provides longer hose life by increasing cooling and reducing friction between the roller and the hose. Always use genuine Graco hose lubricant for maximum hose life.

Follow the directions in [Lubricate the Pump, page 13](#).

Clean the Graco Motor Control

Keep the heat sink fins clean at all times. Clean them using compressed air.

NOTE: Do not use conductive cleaning solvents on the module.

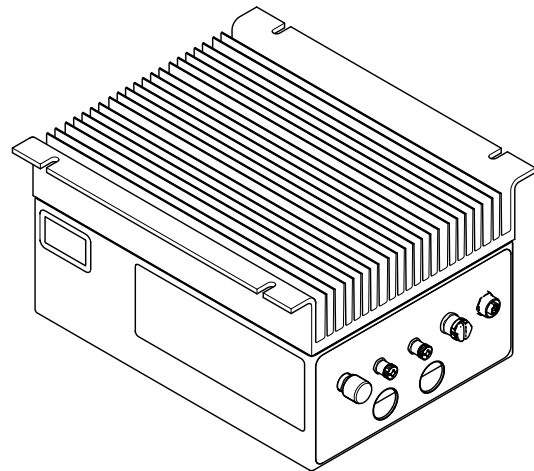

ti25595a

Upgrade Graco Motor Control Software

Use Software Upgrade Kit 17H103 and Programming Cable Kit 24Y788 to update the Graco Motor Control software. The kits include instructions and all necessary parts.

Troubleshooting the Graco Motor Control

Problem	Cause	Solution
Motor does not spin (chatters) and Event code is F1DP, F2DP, or WMC0.	Motor leads are wired incorrectly.	<ul style="list-style-type: none"> • Correctly wire motor according to wiring diagram.
Motor does not spin (chatters) and Event code is T6E0, K6EH, or K9EH.	Feedback cable is disconnected.	<ul style="list-style-type: none"> • Ensure the motor feedback cable is securely connected to both the motor and Connector 1 of the controller. • Remove any external EMI sources if receiving K9EH. • Route feedback cable away from motor power cabling.
Motor does not run at full speed. (Event Codes F1DP, F2DP, V1CB, V9CB)	Input voltage is low.	<ul style="list-style-type: none"> • Ensure the line voltage is at least 108/216 VAC. • Reduce backpressure. • Change input voltage from 120 VAC to 240 VAC.
<p>Motor is hot.</p>  <p>(Event Codes F2DT, T3E0, or T4E0 G307 > 100°C)</p>	System is running outside of the acceptable range for continuous operation.	<ul style="list-style-type: none"> • Reduce the pump back pressure, flow rate, or duty cycle. • Add external cooling to motor (fan). • If receiving T4E0, Max Power Mode can be enabled to automatically reduce pump performance to eliminate overheating.
Membrane buttons do not work or membrane switch works intermittently.	Membrane switch is disconnected.	<ul style="list-style-type: none"> • Ensure the ribbon cable is correctly inserted into the Control board.
PLC control is intermittent or does not function; or Event Codes K6EH, K9EH, L3X0, L4X0 are displayed.	Ribbon cable is disconnected.	<ul style="list-style-type: none"> • Ensure the ribbon cable between the Control board and the Connector board is correctly inserted.
The display is not illuminated or displays intermittently.	Display cable is disconnected.	<ul style="list-style-type: none"> • Ensure the ribbon cable and clip are securely installed in the Control Board.
<ul style="list-style-type: none"> • Control shuts down/resets when cabling is connected to Connector 3. • The Green LED on the Control board or the Power board is off, dimly lit, or blinking. • The Red LED on the Control board is dimly lit or blinking. 	5V supply has shorted.	<ul style="list-style-type: none"> • Disconnect Connector 3. • Correct miswiring. • Reduce current draw on Connector 3 – Pin 1.
	Internal power supply has failed.	<ul style="list-style-type: none"> • Disconnect Connector 3 to validate the 5V supply isn't shorted. • Contact Graco Technical Support.

Problem	Cause	Solution
G200 menus are not displayed after entering password.	An incorrect password has been entered.	<ul style="list-style-type: none"> Enter the correct password. Contact Graco Technical Support for instructions on resetting a password.
GFCI breaker trips when motor is run.	Leakage current exceeds breaker limit.	<ul style="list-style-type: none"> Controller is not compatible with all GFCI circuits. Connect control to non GFCI circuit or an appropriate industrial GFCI circuit.

Diagnostic Information

Table 9 LED Status Signal

Module Status LED Signal	Description	Solution
No LEDs	No system power.	Apply system power.
Green on	System is powered up.	—
Yellow on	Communication with external GCA device is in progress.	—
Red solid	Graco Motor Control hardware failure.	Replace the Graco Motor Control.
Red flashing fast	Uploading software.	Wait until software upload is complete.
Red flashing slow	Bootloader error or error in software upload.	Contact Graco technical support.

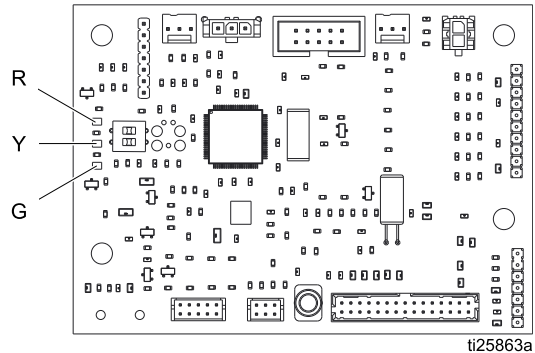

ti25863a

Figure 16 Control Board

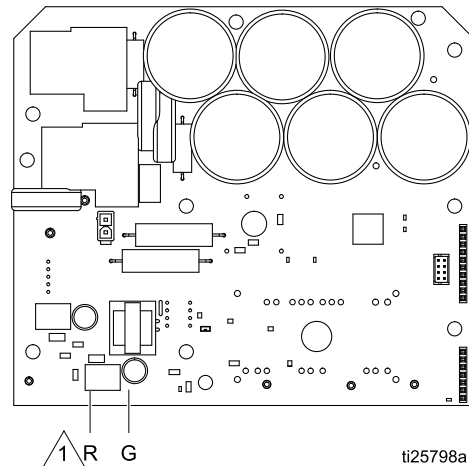

ti25798a

Figure 17 Power Board

△ 1 The red LED is on the back of the board.

Power Line Voltage Surges

Power conversion equipment can be sensitive to voltage fluctuations from the incoming power supply. The Graco Motor Control is considered to be power conversion equipment because energy is stored on a capacitive bus and then modulated to control a brush-less motor. The design of the Graco Motor Control takes this into account, and therefore can withstand a wide range of conditions. However, it is still possible for supplied power to occasionally go outside of the tolerable range in industrial plants with high-amperage reactive pulsed loads, such as welding equipment.

If the tolerable range is exceeded, an over-voltage condition is flagged and the system shuts down in an alarm state for protection and to alert the user of unstable power. Excessive or repeated over-voltage events may permanently damage the hardware.

The MAX-HOLD feature on a multimeter can be used to determine peak DC voltage on the line. DC is the correct setting, as opposed to AC, because peak voltage is the critical parameter that affects the DC voltage level stored on the capacitive bus in power conversion equipment.

Readings should not regularly exceed approximately 400 Vdc to avoid tripping the 420 Vdc alarm level in the Graco Motor Control. If the power quality is suspect, it is recommended to power condition or isolate the device(s) that is causing the poor power quality. Consult a qualified electrician if there are any concerns about the available power supply.

Test Power Line with Multimeter

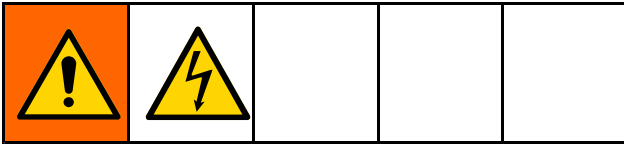

1. Set multimeter to DC voltage.

2. Connect the multimeter probes to the supplied power line.
3. Press Min Max successively to show the peak positive and the negative DC voltages.
4. Confirm that readings do not exceed 400 Vdc (Graco Motor Control alarm is issued at 420 Vdc).

Events

The LED displays event codes to inform the user of any electrical hardware or software problems. After the user acknowledges the error, if the condition is still present in the system:

- **Run Mode:** The display alternates between the event code and the regular display.
- **Setup Mode:** The event code does not display.

Four types of events can occur. All four types are logged and can be viewed on G100.

- **ALARM:** The system immediately stops the pump and displays an event code. The event requires attention and will continue to flash alternately on the Run screen until the operator corrects the condition and clears the alarm.

- **DEVIATION:** The pump continues to run. The event requires attention and will continue to flash alternately on the Run screen until the operator corrects the condition and clears the alarm.
- **ADVISORY:** The event flashes on the Run screen for one minute and is logged. The pump continues to run and the event does not require operator attention.
- **RECORD:** The event is logged but does not display. The pump continues to run and the event does not require operator attention.

Event Code	Event Level	Description	Solution
A4CH	Alarm	Motor current has exceeded the hardware limit.	Check operating conditions to determine the source of the alarm. Event will clear after acknowledgment.
A4CS	Alarm	Motor current has exceeded the software limit.	Check operating conditions to determine the source of the alarm. Event will clear after acknowledgment.
CACC	Alarm	A communication problem has been detected on the Control board.	Check the connection between the Control and Power boards.
CACH	Alarm	A communication problem has been detected on the Power board.	Check the connection between the Control and Power boards.
EBC0	Deviation	The pumping process has been interrupted. The pump is decelerating or batching and is commanded to stop.	Event will clear after acknowledgment. Do not interrupt the process.
EBG0	Alarm	The local Stop button was pressed on a system set for Remote Start/Stop Control, or Full Remote Control. The local button overrides the external control.	Press the Start button to clear Alarm and resume remote control.
EL00	Record	Indicates power has been applied to the system	None.
ES00	Record	All memory has been erased and the settings have been set to factory defaults.	None.
F1DH	Alarm	The system has detected an increase in downstream fluid restriction and has stopped.	Remove the downstream blockage and restart the pump. If normal downstream operation causes fluid pressure spike alarms, increase the G214 value (lower sensitivity). If G214 is already set to 5, consider disabling G214.

Event Code	Event Level	Description	Solution
F1DP	Alarm	The motor control limit has been reached and Max Power Mode is disabled in menu G204. The controller is at maximum line current, maximum motor current, or maximum output voltage and cannot maintain the flow setpoint.	Reduce pump flow/pressure. Enable Max Power Mode (menu G204).
F2DP	Deviation	The motor control limit has been reached and Max Power Mode is enabled in menu G204. The controller is at maximum line current, maximum motor current, or maximum output voltage, but the motor will continue to run at a reduced performance.	Reduce pump flow/pressure.
F2DT	Deviation	The motor temperature is above 120°C (248°F) and Max Power Mode is enabled in menu G204. The output current is being limited, but the system will run at a reduced performance.	Reduce pump flow/pressure or duty cycle.
FCDH	Deviation	HoseGuard has been enabled (G214>0) but is not yet active (not calibrated).	Ensure the downstream system is free of blockages. Turn on the pump and let it complete 1 full revolution at operational speed.
K4E0	Alarm	The motor speed has exceeded the maximum.	Event will clear after acknowledgment. Check operating conditions to determine the source of the alarm.
K6EH	Alarm	The position sensor has read an invalid position, likely because it is not connected.	Ensure the feedback cable is correctly installed and away from any external noise sources.
K9EH	Deviation	Position errors (skips, momentary invalid positions) have been detected. Likely due to noise on the motor feedback cable.	Ensure the feedback cable is correctly installed and away from any external noise sources.
L3X0	Deviation	The pump leak sensor has detected a leak and the Pump Leak Type is set to Deviation in G206. The pump continues to run.	Replace worn parts to stop leak, drain leak sensor and replace.
L4X0	Alarm	The pump leak sensor has detected a leak and the Pump Leak Type is set to Alarm in G206. The pump has been stopped.	Replace worn parts to stop leak, drain leak sensor and replace.
MA01	Advisory	The maintenance pump cycles have exceeded the number set on menu G230.	Clear the Maintenance Counter (menu G130).
MA02	Advisory	The maintenance pump cycles have exceeded the number set on menu G231.	Clear the Maintenance Counter (menu G131).
MA03	Advisory	The maintenance pump cycles have exceeded the number set on menu G232.	Clear the Maintenance Counter (menu G132).

Event Code	Event Level	Description	Solution
T3E0	Deviation	The internal motor temperature is above 100°C (212°F).	Reduce pump flow or duty cycle.
T4C0	Alarm	The internal IGBT module temperature has exceeded the limit of 100°C (212°F).	Reduce power output or decrease ambient temperature.
T4E0	Alarm	The internal motor temperature is above 150°C (302°F) and Max Power Mode is disabled in G204.	Reduce pump flow or duty cycle. Enable Max Power Mode (G204).
T6E0	Alarm	The motor is operating out of its temperature range or the temperature sensor signal is lost.	Ensure that the motor ambient temperature is above minimum. Ensure that the feedback cable is correctly installed. Ensure the TO1/TO2 wires from the Control board are correctly inserted into the Connector board. Contact Graco technical assistance.
V1CB	Alarm	Bus voltage is below minimum acceptable limit.	Check the voltage source level.
V2CG	Deviation	IGBT Gate drive voltage is below minimum acceptable limit.	Contact Graco technical assistance.
V4CB	Alarm	Bus voltage is above maximum acceptable limit.	Increase pump deceleration time. Check the voltage source level.
V9CB	Alarm	Bus voltage measurement circuit is reporting abnormally low values when AC power is detected.	Check the voltage source level. Contact Graco technical assistance.
V9MX	Alarm	Loss of AC power has been detected.	Reconnect AC power.
WMC0	Alarm	The controller is not able to turn the motor (locked rotor).	Free the motor rotor, then restart the motor.
WSCP	Alarm	The user has not selected a pump size on menu G401.	Select pump size.
WSCS	Alarm	The software version or part number reported by the Power board does not match the expected values.	If a software upgrade has recently failed/ been interrupted, try again. If not, contact Graco technical assistance.
WX00	Alarm	An unexpected software error has occurred.	Event will clear after acknowledgment. Contact Graco technical assistance.

Dimensions

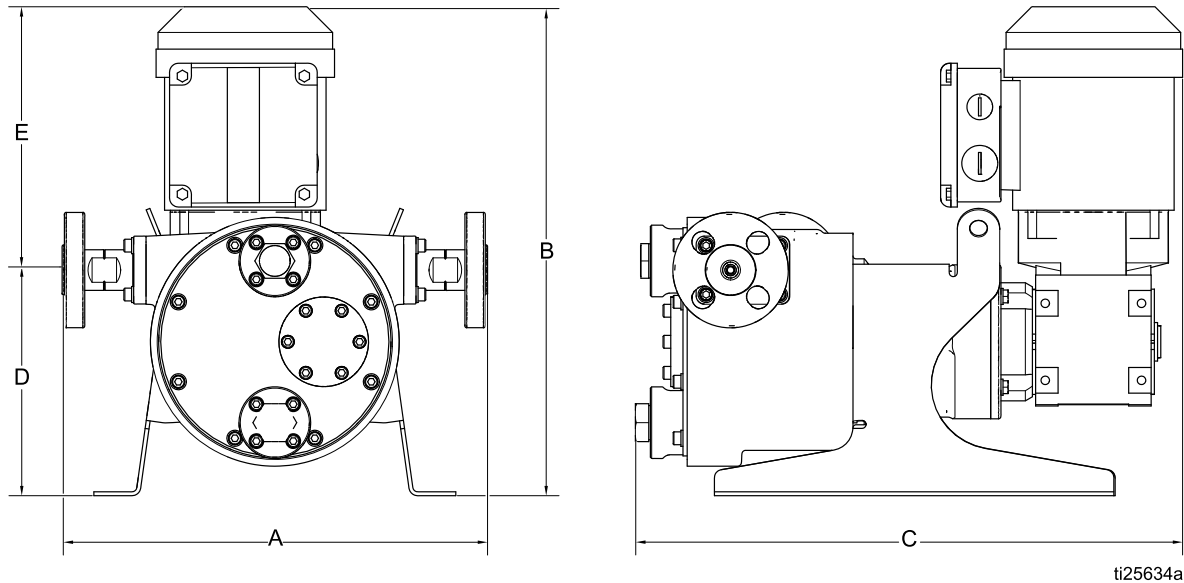

Figure 18 ST10, ST23, and ST30 AC Pumps

	A		B		C		D		E	
	in.	cm	in	cm	in	cm	in	cm	in	cm
ST10 HAC	13.0	33.0	18.2	46.2	16.2	41.1	7.0	17.8	11.2	28.4
ST10 MAC	13.0	33.0	17.3	43.9	16.2	41.1	7.0	17.8	10.3	26.2
ST10 LAC	13.0	33.0	16.7	42.4	16.2	41.1	7.0	17.8	9.7	24.6
ST23 HAC	17.2	43.7	20.5	52.1	19.8	50.3	10.1	25.7	9.9	25.1
ST23 MAC	17.2	43.7	20.5	52.1	19.8	50.3	10.1	25.7	9.9	25.1
ST 23 LAC	17.2	43.7	18.2	46.2	19.8	50.3	10.1	25.7	8.1	20.6
ST30 HAC	23.3	59.2	30.3	77.0	26.5	67.3	16.1	40.9	14.2	36.1
ST30 MAC	23.3	59.2	29.1	73.9	26.5	67.3	16.1	40.9	13.1	33.3

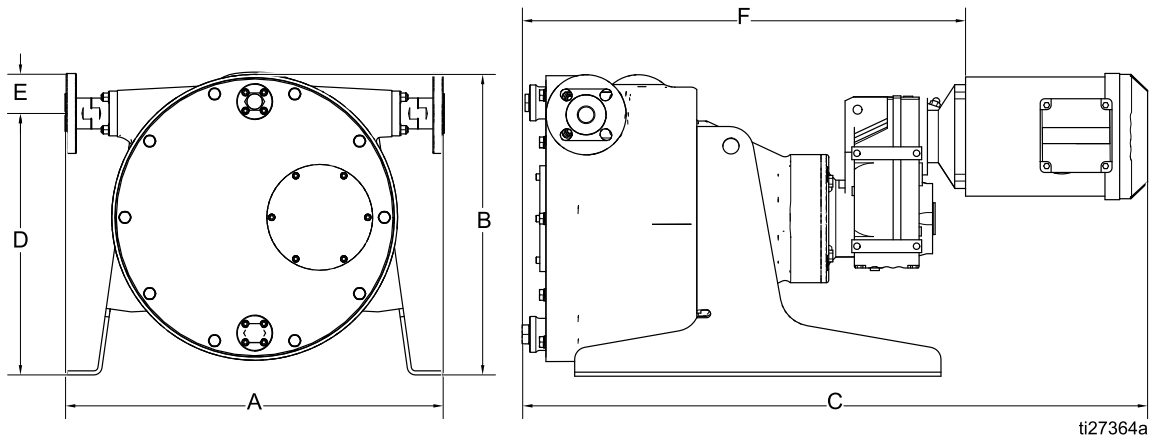

Figure 19 ST26 and ST30 AC Pumps

	A		B		C		D		E	
	in.	cm	in	cm	in	cm	in	cm	in	cm
ST26 HAC	21.7	55.1	16.5	41.9	36.1	91.7	14.0	35.6	2.0	5.1
ST26 MAC	21.7	55.1	16.5	41.9	33.9	86.1	14.0	35.6	2.0	5.1
ST26 LAC	21.7	55.1	15.5	39.4	33.0	83.8	14.0	35.6	2.0	5.1
ST 30 LAC	23.3	59.2	20.0	50.8	34.4	87.4	16.1	40.9	2.5	6.4

Dimensions

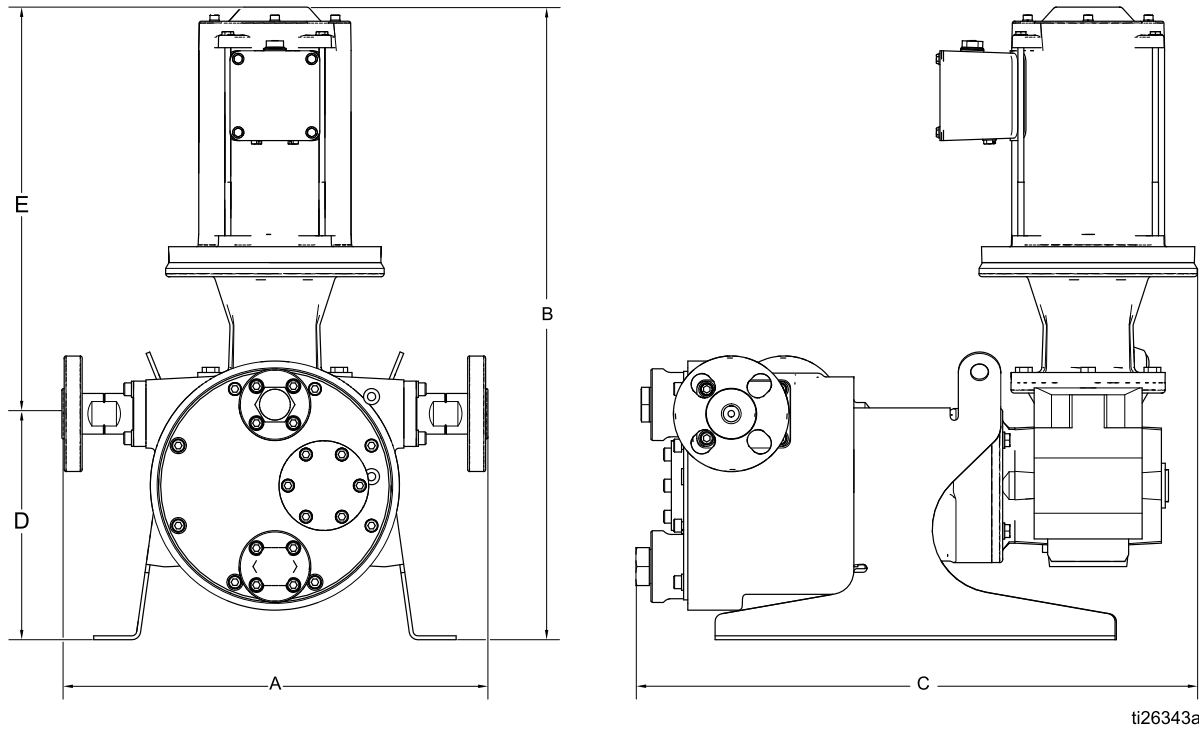

Figure 20 ST10 and ST23 BLDC Pumps

	A		B		C		D		E	
	in.	cm	in	cm	in	cm	in	cm	in	cm
ST10 MPM	13.0	33.0	21.0	53.3	16.3	41.4	7.0	17.8	14.1	35.8
ST23 MPM	17.2	43.7	22.8	57.9	19.8	50.3	10.1	25.7	12.8	32.5

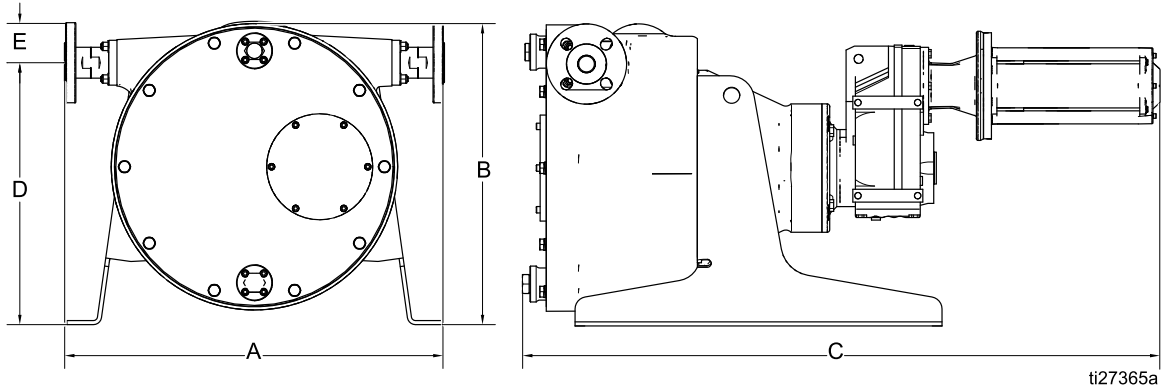
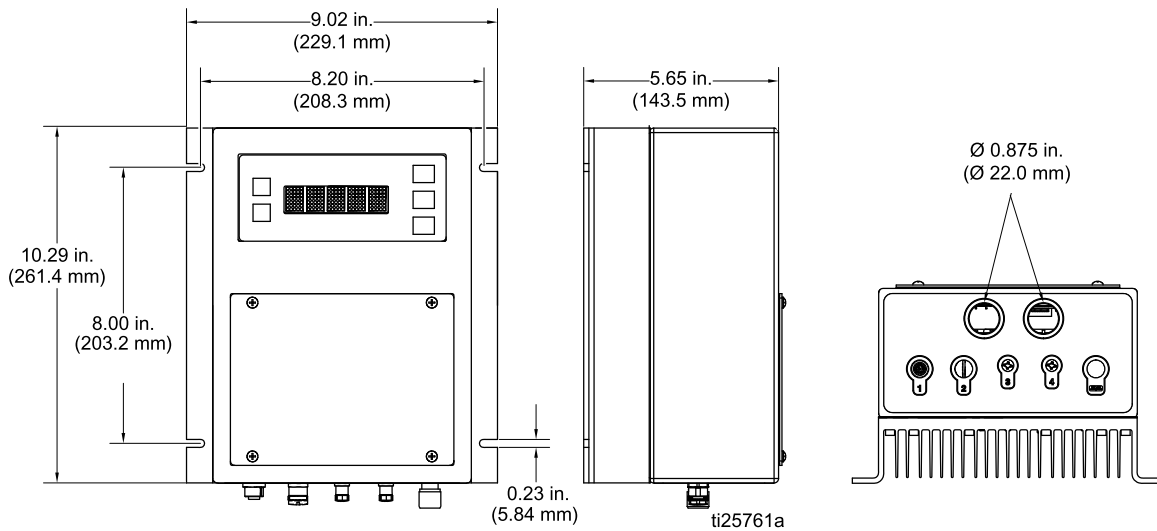

Figure 21 ST26 and ST30 BLDC Pump

	A		B		C		D		E	
	in.	cm	in	cm	in	cm	in	cm	in	cm
ST26 MPM	21.7	55.1	16.0	40.6	36.8	93.5	14.0	35.6	2.0	2.1
ST30 MPM	23.3	59.2	18.5	47.0	40.4	102.6	16.1	40.9	2.5	6.4

Graco Motor Control Dimensions

Used with pumps with BLDC motors.



Mounting Hole Layouts

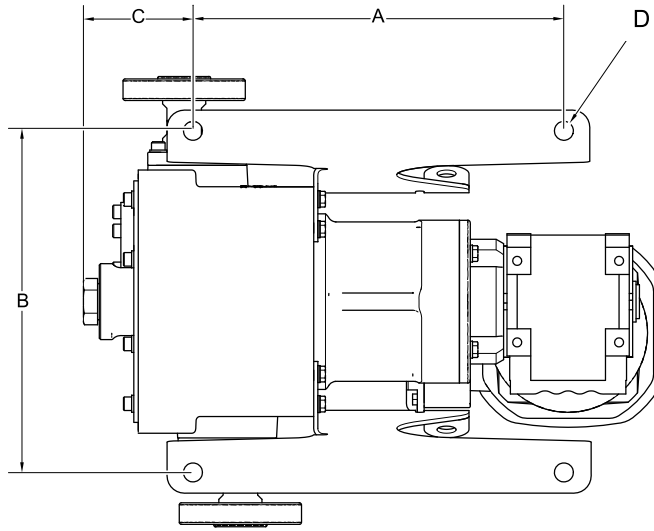

ti25635a

Pump Model	A		B		C		D	
	in.	mm	in.	mm	in.	mm	in.	mm
ST10	10.8	273	9.9	251	3.2	81	0.6	14
ST23	13.3	338	14.4	366	4.5	115	0.7	18
ST26	15.5	394	18.9	480	4.7	119	0.7	18
ST30	20.4	518	21.4	544	4.2	107	0.7	18

Performance Data

NOTE: As back pressure increases, flow rate may decrease, especially for low-viscosity fluids at low cycle rates.

Data were obtained using water as a medium with no back pressure.

A	LAC Motor (low speed)
B	MAC Motor (medium speed)
C	HAC Motor (high speed)
D	MPM Brushless DC motor
Shading indicates the recommended continuous duty range.	

ST10 — Theoretical Flow Rate

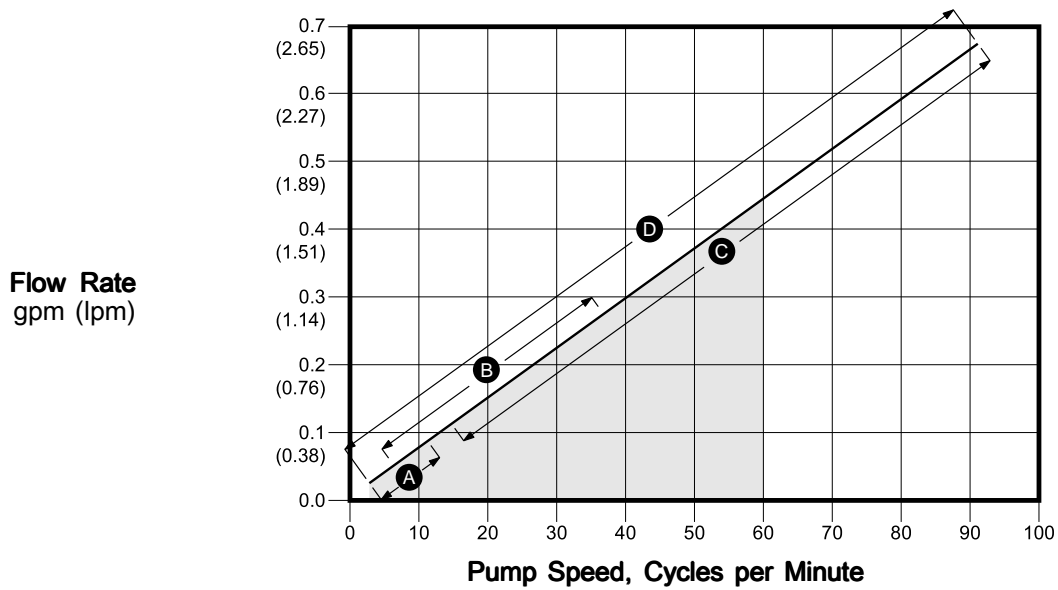

ST23 — Theoretical Flow Rate

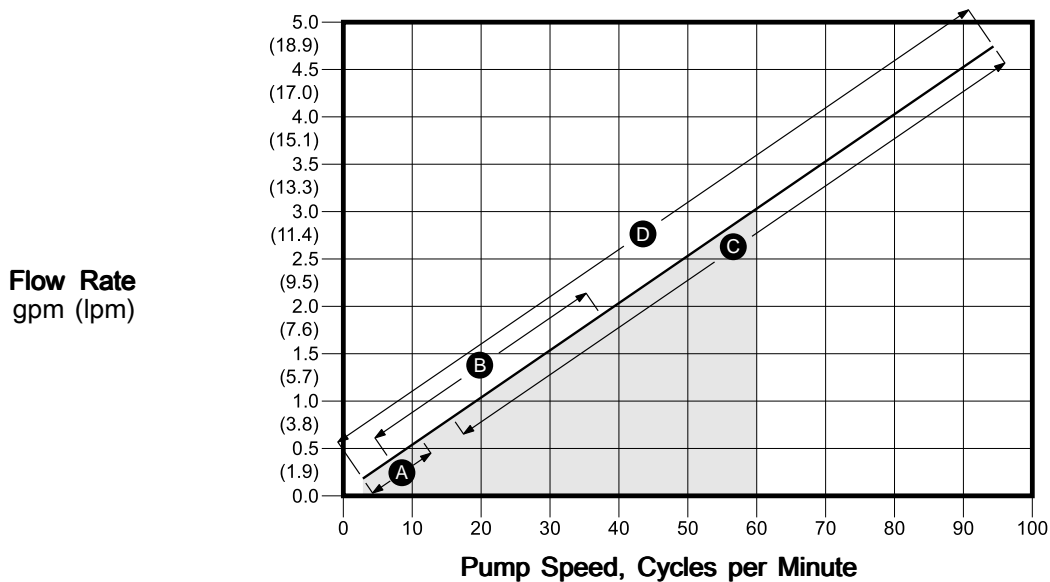

Data were obtained using water as a medium with no back pressure.

A	LAC Motor (low speed)
B	MAC Motor (medium speed)
C	HAC Motor (high speed)
D	MPM Brushless DC motor
Shading indicates the recommended continuous duty range.	

ST26 — Theoretical Flow Rate

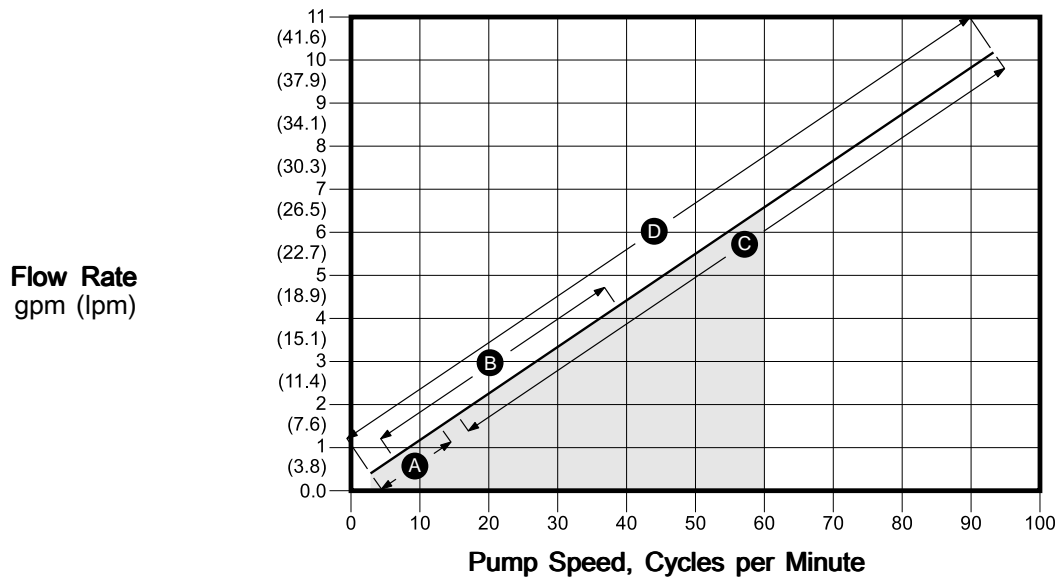

ST30 — Theoretical Flow Rate

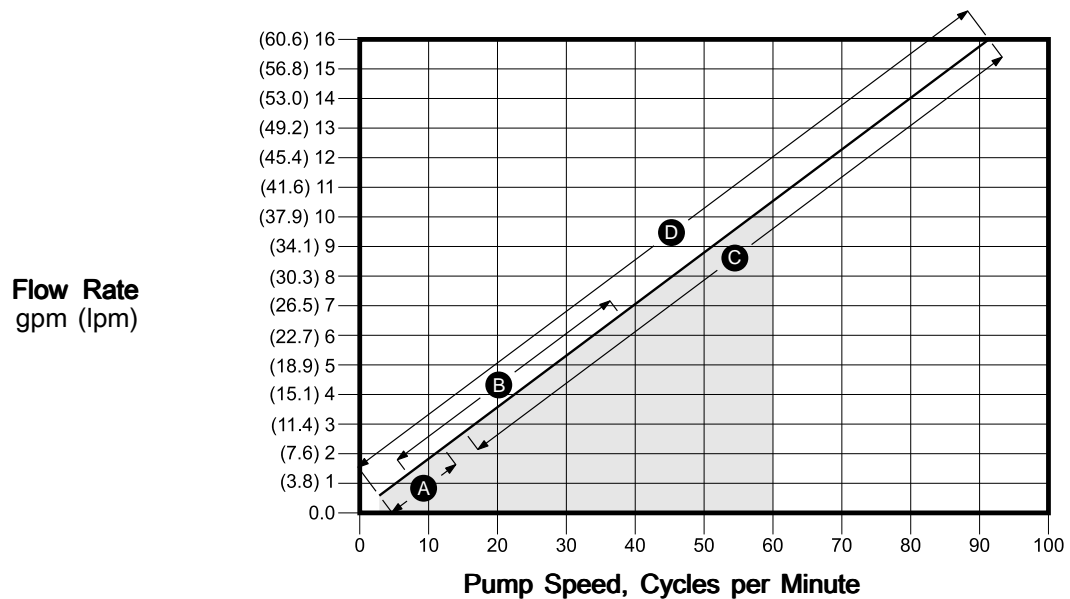

Performance Data

Multiply the pump speed by the scaling factor shown in this table to obtain an approximate VFD frequency (Hz). **Example:** An ST23–MAC pump running at 30 cpm has a VFD frequency of about 49.5 Hz.

Table 10 Flow to Frequency Conversions for AC Pumps

$$\text{Desired Pump Speed (cpm)} * \text{Scaling Factor} = \text{VFD Frequency (Hz)}$$

Model	Scaling Factor (SEW Gearbox)	Scaling Factor (Nord Gearbox)
ST10–HAC	0.67	0.66
ST10–MAC	1.65	1.60
ST10–LAC	5.40	4.50
ST23–HAC	0.66	0.66
ST23–MAC	1.65	1.60
ST23–LAC	5.40	4.50
ST26–HAC	0.66	0.66
ST26–MAC	1.61	1.53
ST26–LAC	4.97	5.50
ST30–HAC	0.68	0.63
ST30–MAC	1.65	1.65
ST30–LAC	5.14	5.30

Technical Data

SoloTech Peristaltic Pumps		
	U.S.	Metric
Maximum Fluid Working Pressure	125 psi	0.9 MPa, 9 bar
Motor Horsepower/Gear Ratio	See the identification tag on your gear motor.	
Maximum Pump Speed	90 RPM	
Environmental Temperature Range (Do not allow material to freeze in the pump.)	14°F to 104°F	-10°C to 40°C
Maximum Flow		
ST10	0.67 gpm	2.5 lpm
ST23	4.5 gpm	17.0 lpm
ST26	9.8 gpm	37.1 lpm
ST30	15.8 gpm	59.8 lpm
Fluid Capacity per Revolution		
ST10	0.007 gal.	0.03 l
ST23	0.054 gal.	0.20 l
ST26	0.11 gal.	0.42 l
ST30	0.18 gal.	0.68 l
Flange Dimensions		
ST10		
Outer Diameter	3.54 in.	90 mm
Bolt Circle	2.30–2.56 in.	58–65 mm
Bolt Size	1/2 in.	
ST23 and ST26		
Outer Diameter	4.25 in.	108 mm
Bolt Circle	2.95–3.13 in.	75–80 mm
Bolt Size	1/2 in.	
ST30		
Outer Diameter	4.92 in.	125 mm
Bolt Circle	3.35–3.54 in.	85–90 mm
Bolt Size	1/2 in.	
Hose Inner Diameter		
ST10	0.39 in.	10 mm
ST23	0.91 in.	23 mm
ST26	1.02 in.	26 mm
ST30	1.18 in.	30 mm
Weight		
ST10	55–65 lbs	25–29 kg
ST23	100–120 lbs.	45–54 kg
ST26	190–215 lbs.	86–98 kg
ST30	235–285 lbs	107–129 kg

Technical Data

SoloTech Peristaltic Pumps		
	U.S.	Metric
Noise		
Sound Pressure	Less than 70 dB(A)	
Wetted Parts		
Hose options	Natural Rubber, CSM, NBR	
Barbed fitting options	Stainless steel, PVDF	
Technical Specifications for the Graco Motor Control (All installations and wiring must comply with NEC and local electrical codes.)		
DC Power Supply	Class 2 Power Supply only	
Approvals	UL508C	
Conformity	CE-Low Voltage (2006/95/EC), EMC (2004/108/EC), and RoHS (2011/65/EU) Directives	
Ambient Temperature	-40°F – 104°F	-40°C – 40°C
Environment Rating	Type 4X, IP 66	
Overtemperature Sensing Specifications (The drive is provided with a means to accept and act upon a signal from a thermal sensor in the motor. Motor overtemperature sensing is required to provide the motor overload protection.)	0–3.3 VDC, 1mA maximum	
Weight	10.5 lb.	4.8 kg
Input Specifications		
Input Line Voltage	120/240 VAC, line-to-line	
Input Line Phasing	Single Phase	
Input Line Frequency	50/60 Hz	
Input Current per Phase	16A	
Maximum Branch Circuit Protection Rating	20A, Inverse Time Circuit Breaker	
Short Circuit Current Rating	5 kA	
Output Specifications		
Output Line Voltage	0–264 VAC	
Output Line Phasing	Three Phase	
Output Current (Current limit, set via the software, is provided as a secondary protection from motor overload.)	0–12A	
Output Power	1.92 KW / 2.6 hp	
Output Overload	200% for 0.2 seconds	

Optional Leak Sensor	
Contact Ratings:	
State	Normally open
Voltage	200 VAC/VDC max.
Current	1.25 A DC or peak AC
Power	10 W max
Ambient Temperature	-5°C to 80°C (23°F to 176°F)
Ex Ratings:	
Classification	<p>"simple apparatus" in accordance with UL/EN/IEC 60079-11, clause 5.7</p> <p>Class I, Div 1, Group A, B, C, D T4 -5°C T_a 80°C</p> <p> II 1 G Ex ia IIC T4 Ga -5°C T_a 80°C</p>
Parameters	<p>U_i = 24 V I_i = 280 mA P_i = 1.0 W C_i = 2.8 pF L_i = 0.8 μH</p>

Graco Standard Warranty

Graco warrants all equipment referenced in this document which is manufactured by Graco and bearing its name to be free from defects in material and workmanship on the date of sale to the original purchaser for use. With the exception of any special, extended, or limited warranty published by Graco, Graco will, for a period of twelve months from the date of sale, repair or replace any part of the equipment determined by Graco to be defective. This warranty applies only when the equipment is installed, operated and maintained in accordance with Graco's written recommendations.

This warranty does not cover, and Graco shall not be liable for general wear and tear, or any malfunction, damage or wear caused by faulty installation, misapplication, abrasion, corrosion, inadequate or improper maintenance, negligence, accident, tampering, or substitution of non-Graco component parts. Nor shall Graco be liable for malfunction, damage or wear caused by the incompatibility of Graco equipment with structures, accessories, equipment or materials not supplied by Graco, or the improper design, manufacture, installation, operation or maintenance of structures, accessories, equipment or materials not supplied by Graco.

This warranty is conditioned upon the prepaid return of the equipment claimed to be defective to an authorized Graco distributor for verification of the claimed defect. If the claimed defect is verified, Graco will repair or replace free of charge any defective parts. The equipment will be returned to the original purchaser transportation prepaid. If inspection of the equipment does not disclose any defect in material or workmanship, repairs will be made at a reasonable charge, which charges may include the costs of parts, labor, and transportation.

THIS WARRANTY IS EXCLUSIVE, AND IS IN LIEU OF ANY OTHER WARRANTIES, EXPRESS OR IMPLIED, INCLUDING BUT NOT LIMITED TO WARRANTY OF MERCHANTABILITY OR WARRANTY OF FITNESS FOR A PARTICULAR PURPOSE.

Graco's sole obligation and buyer's sole remedy for any breach of warranty shall be as set forth above. The buyer agrees that no other remedy (including, but not limited to, incidental or consequential damages for lost profits, lost sales, injury to person or property, or any other incidental or consequential loss) shall be available. Any action for breach of warranty must be brought within two (2) years of the date of sale.

GRACO MAKES NO WARRANTY, AND DISCLAIMS ALL IMPLIED WARRANTIES OF MERCHANTABILITY AND FITNESS FOR A PARTICULAR PURPOSE, IN CONNECTION WITH ACCESSORIES, EQUIPMENT, MATERIALS OR COMPONENTS SOLD BUT NOT MANUFACTURED BY GRACO. These items sold, but not manufactured by Graco (such as electric motors, switches, hose, etc.), are subject to the warranty, if any, of their manufacturer. Graco will provide purchaser with reasonable assistance in making any claim for breach of these warranties.

In no event will Graco be liable for indirect, incidental, special or consequential damages resulting from Graco supplying equipment hereunder, or the furnishing, performance, or use of any products or other goods sold hereto, whether due to a breach of contract, breach of warranty, the negligence of Graco, or otherwise.

FOR GRACO CANADA CUSTOMERS

The Parties acknowledge that they have required that the present document, as well as all documents, notices and legal proceedings entered into, given or instituted pursuant hereto or relating directly or indirectly hereto, be drawn up in English. Les parties reconnaissent avoir convenu que la rédaction du présente document sera en Anglais, ainsi que tous documents, avis et procédures judiciaires exécutés, donnés ou intentés, à la suite de ou en rapport, directement ou indirectement, avec les procédures concernées.

Graco Information

For the latest information about Graco products, visit www.graco.com.
For patent information, see www.graco.com/patents.

To place an order, contact your Graco Distributor or call to identify the nearest distributor.

Phone: 612-623-6921 **or Toll Free:** 1-800-328-0211 **Fax:** 612-378-3505

All written and visual data contained in this document reflects the latest product information available at the time of publication.

Graco reserves the right to make changes at any time without notice.
Original Instructions. This manual contains English. MM 3A4056

Graco Headquarters: Minneapolis
International Offices: Belgium, China, Japan, Korea

GRACO INC. AND SUBSIDIARIES • P.O. BOX 1441 • MINNEAPOLIS MN 55440-1441 • USA
Copyright 2017, Graco Inc. All Graco manufacturing locations are registered to ISO 9001.