

Air Motor Seal Kit

313222A

To replace air motor seals on Reactor[®] A-20 Proportioner.



Important Safety Instructions

Read all warnings and instructions in manual 311512. Save those instructions.

- 1 Press fit bushing with flange bottomed against counterbore step.
- 2 Install seal into internal groove of bushing with vee facing flange end.
- 3 Apply Loctite 414 adhesive to bushing threads after bushing pressed into plate and before nut installed on bushing.

Note: See manual 311512 for installation and lubrication instructions.

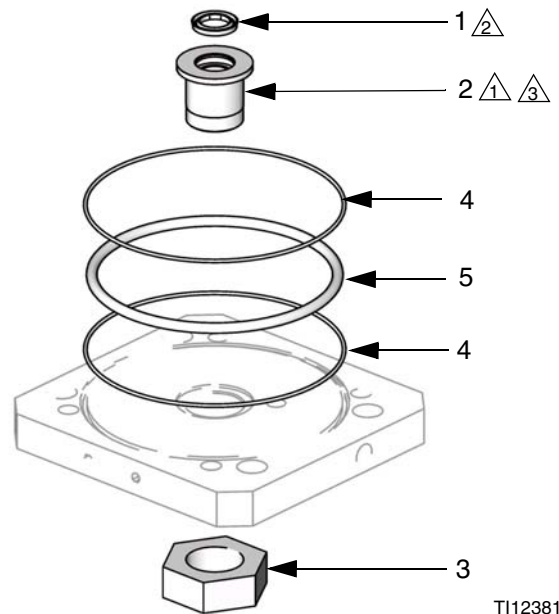

TI12381a

Parts included with kit 255057:

Ref.	Part	Description	Qty.
1	120554	SEAL, u-cup, bevel lip	1
2	15J149	BUSHING, rod, air motor	1
3	121601	NUT, 1 1/8-12 unf; acetal	1
4	296112	O-RING, #049; buna-n	2
5	296113	O-RING, #350; buna-n	1

*All written and visual data contained in this document reflects the latest product information available at the time of publication.
Graco reserves the right to make changes at any time without notice.*

This manual contains English. MM 313222

Graco Headquarters: Minneapolis

International Offices: Belgium, China, Japan, Korea

GRACO INC. P.O. BOX 1441 MINNEAPOLIS, MN 55440-1441

Copyright 2008, Graco Inc. is registered to I.S. EN ISO 9001

www.graco.com

7/2008