

Mobile Lubrication Library

Komatsu HM300-5 / HM400-5

Installation Instructions



Instructions for installing a Graco automatic lubrication system on the Komatsu HM300-5 or HM400-5.

Part No. 17G146

Maximum System Working Pressure: 2750 psi (18.96 MPa, 189.6 bar)



Important Safety Information

Read all warnings and instructions in all Graco related component manuals and all Komatsu equipment manuals. Save all instructions.

Related Graco Component Manuals*

Manual No.	Manual Title
332291	G3 Pump
3A2960	GLC2200 Controller
312497	MSP Divider Valves

**Refer to these instruction manuals for additional information related to the installation and operation of system components.*

WARNING



FLUID INJECTION HAZARD



Fluid leaks from incorrectly installed or ruptured components, and/or failure to verify the components are properly installed and tested, can result in serious injury such as fluid spraying in the eyes or on skin and fluid injection, or equipment damage. Installation must be done by a qualified professional or Komatsu certified technician and tested prior to use.



The information contained in this document is only a recommendation for an automatic lubrication system and is not intended to replace the installation and maintenance instructions provided by the original equipment manufacturer.

Table of Contents

Installation Checklist	3
Recommended Tools and Supplies	4
Installation Notes	4
Typical Installation - HM300-5	5
Typical Installation - HM400-5	6
Installation	7
Before You Start	7
Grease Point Fittings	8
MSP Divider Valve Assembly	17
MSP Valve Component Identification	17
MSP Divider Valve Assembly	17
MSP Divider Valve Assembly	20
Weld Studs	21
General Information	21
Dump Body Guards	22
Weld Stud and MSP Master Divider Valve Installation	24
G3 Pump	28
Installing the G3 Pump to the Filter Cover	29
Remote Fill Installation	32
Proximity Switch Cable	36
GLC2200 Controller Wiring	37
GLC2200 Controller	41
Hose Assemblies	43
Hose Assembly Instructions	43
Hose Routing	47
Pump to Master Divider Valve	47
Master Valve to Secondary Valves	52
Guarding and P-Clamp	54
GLC2200 Controller Programming	55
Filling and Purging	58
Testing	59
Routine Service and Equipment Maintenance ..	59
Troubleshooting	60
Parts	63
Graco Information	64

Installation Checklist

The following checklist is provided as a tool to ensure all installation procedures are completed.

Completed	Description	Page
	Walk around the truck; use a grease gun to verify that all lube points receive grease.	7
	Grease all zerks, before removal	7
	Remove zerks and Komatsu extensions.	7
	Clean threads with a 1/8 in. NPT tap	7
	Install grease point fittings	8
	Assemble MSP Divider Valves	17
	Cut guarding to length; clean, debur and paint	22
	Install weld studs and Middle/Rear Secondary Divider Valves	26
	Assemble the G3 pump and fittings	28
	Install G3 pump to filter cover	29
	Install remote fill	32
	Install and route G3 power cable	34
	Mount GLC2200 Controller	34
	Route the proximity switch cable from the Master Divider Valve into the cab	36
	Wire GLC2200 Controller	38
	Cut hoses to length, apply hose wraps and fittings	43
	Hose Routing between Divider Valves and Grease Points. DO NOT CONNECT	46
	Installing Guards and P-clamps to dump body; route hoses	56
	Program GLC2200 Controller	57
	Fill the G3 pump reservoir with grease; purge the main feed line	60
	Run test program; verify all connections are tight; verify all points are receiving lubricant	61

Recommended Tools and Supplies

Tool	Size/Description	
	US	Metric
Combination wrench*	1/4 in. - 3/4 in.	6 mm - 20 mm
Socket set, standard and deep well with ratchet*	3/8 in. - 3/4 in.	9.5 mm - 20 mm
Screwdrivers: standard and Phillips	1 short; 1 long	
Adjustable wrench	1 small; 1 medium	
High speed drill (corded or cordless)		
Drill bit - steel, high quality	5/16 in., 11/16 in.	
Center punch	fine point	
Pipe taper tap	1/8 in. NPT	
Hammer		
Angle grinder		
Grinding disc	Heavy grade grinding disc	
Flap disc	60 - 80 grit	
Cutoff disc	High quality disc	
Cutting blade / knife	Razor blade cutting tool	
Standard pliers	Rubber handle	
Needle nose pliers	Rubber handle	
Side cut pliers (diagonal cutters)	Rubber handle	
Slip joint pliers	Rubber handle	
Locking pliers	Small or medium	
Electrician's wire stripper / crimper	General duty wire stripper / crimper	
Soldering iron	30 watt minimum	
Electrical solder		
Soldering flux		
Shrink tubing	Various sizes	
Electrical tape	Black, small roll	
Thread sealant	Liquid thread sealant such as Loctite® 656	
Multi-tester / voltmeter	Must test DC/AC/Ohms	
Electrical connectors	Ring connectors (14 gauge)	
Tape measure	Standard / metric	
Komatsu primer and paint	Color should match the Komatsu equipment	
Documentation / writing implements	Small note pad, pen, pencil, marker	

*Both US and Metric sizes of these tools are recommended.

Loctite® is a registered trademark of the Henkel Corporation.

All other Trademarks used herein are the property of their respective owners.

Installation Notes

- Do not use PTFE tape on fitting threads. Liquid pipe sealant is recommended for use in lubrication systems to eliminate the potential for contamination. If you must use PTFE tape, always skip the first two threads on the fitting.
- Refer to the Installation Checklist provided on page 3 to ensure all installation procedures have been completed.
- Prime and paint all bare metal surfaces prior to installation with matching Komatsu primer and paint.

Typical Installation - HM300-5

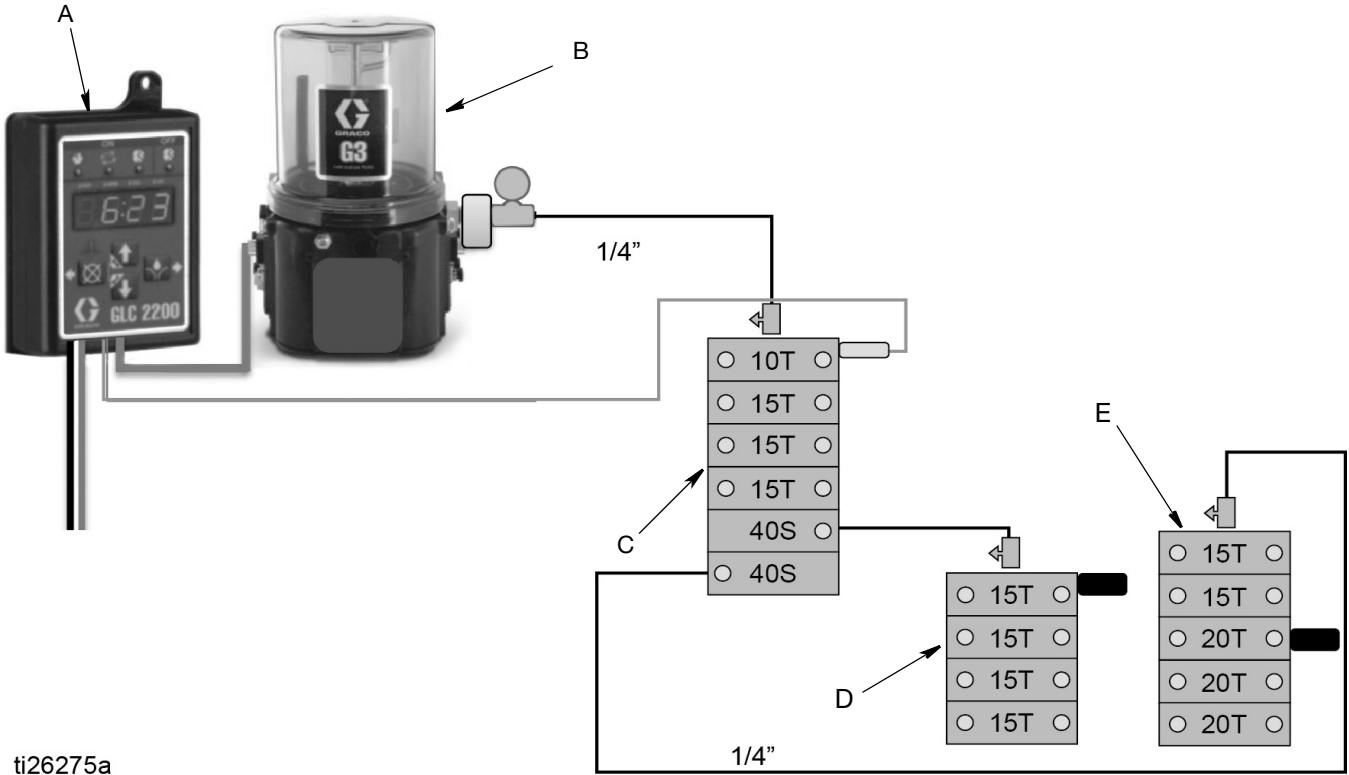

ti26275a

Key

- A GLC2200 Controller
- B G3 Automatic Lubrication Pump
- C MSP Master/Secondary Divider Valve
- D MSP Secondary Divider Valve - Middle Secondary
- E MSP Secondary Divider Valve - Rear Secondary

Cycle Timing

MODEL	Pump ON Time	Pump OFF Time	Master Valve Cycles
HM300-5	5 minutes	45 minutes	2 times

NOTE: Photographs may include optional equipment.

Typical Installation - HM400-5

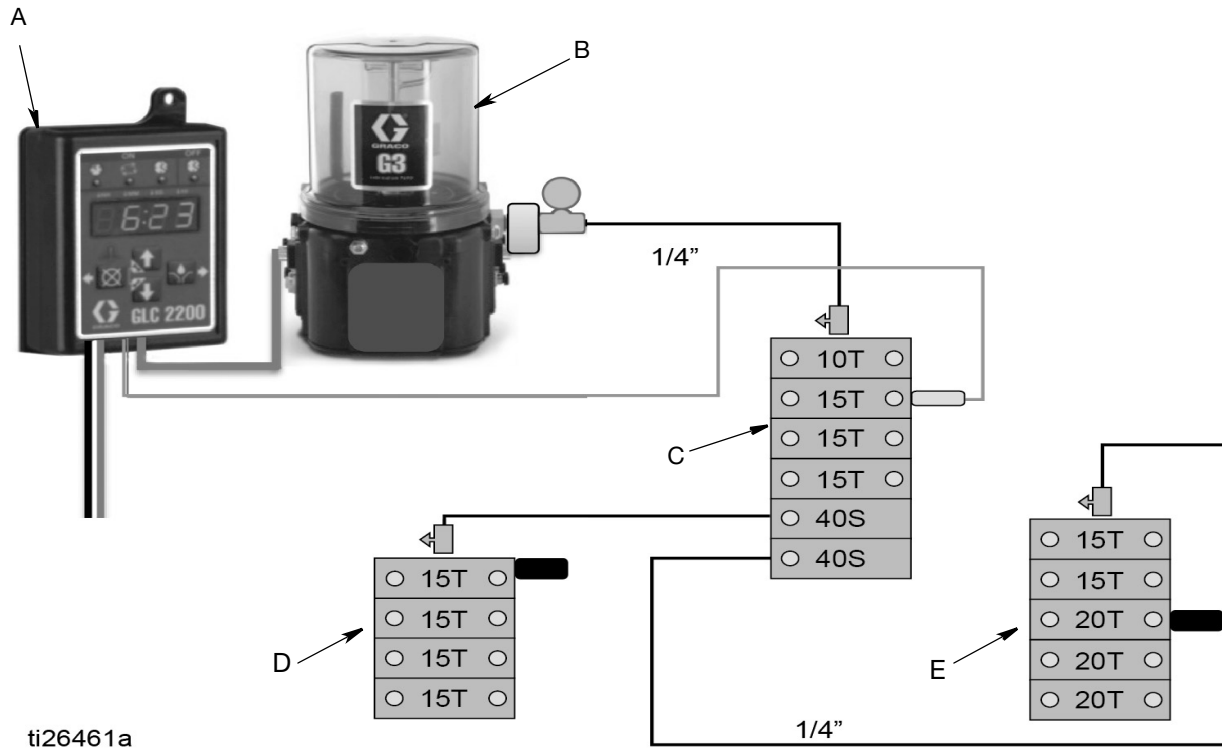

Key



- A GLC2200 Controller
- B G3 Automatic Lubrication Pump
- C MSP Master/Secondary Divider Valve
- D MSP Secondary Divider Valve - Middle Secondary
- E MSP Secondary Divider Valve - Rear Secondary

Cycle Timing

MODEL	Pump ON Time	Pump OFF Time	Master Valve Cycles
HM400-5	5 minutes	45 minutes	2 times

Installation

Before You Start

 <b style="font-size: 24px; margin-left: 10px;">WARNING	
 	<p>Disconnect battery before installing the lubrication equipment. Installing lubrication equipment on powered machinery could result in serious injury from skin injection or parts moving unexpectedly.</p>

1. Walk around the machine with a grease gun and verify that every grease point is accepting grease. (Refer to FIG. 1, page 8 to identify lubrication points). This will ensure that the valves can dispense grease to the grease points by identifying potentially blocked passages from the grease zerk to the grease point.

Zerk Fittings

- a. Use a clean cloth or rag to remove excessive grease, contaminants and dirt from the work area.
 - b. Remove all grease zerks and Komatsu extensions from their installation locations.
 - c. Use a clean cloth or rag to remove any remaining grease, contaminants or dirt from the area around the passage way to the grease points.
2. For some installation procedures the truck must be articulated or modified. If you are unsure of how to perform these tasks, consult the Komatsu operation and maintenance manual or have a qualified Komatsu technician configure the truck as needed.

These procedures include:

- Tilting the cab back
- Raising the dump bed
- Rotate dump body rod end cylinders 180°

Grease Point Fittings

1. Apply thread sealant to supplied grease point fittings.
2. Install fittings in grease points. Refer to FIG. 1 and the related table for installation locations and parts.
3. Refer to Grease Point Table, beginning on page 13, to determine the Bearing Points on your model.

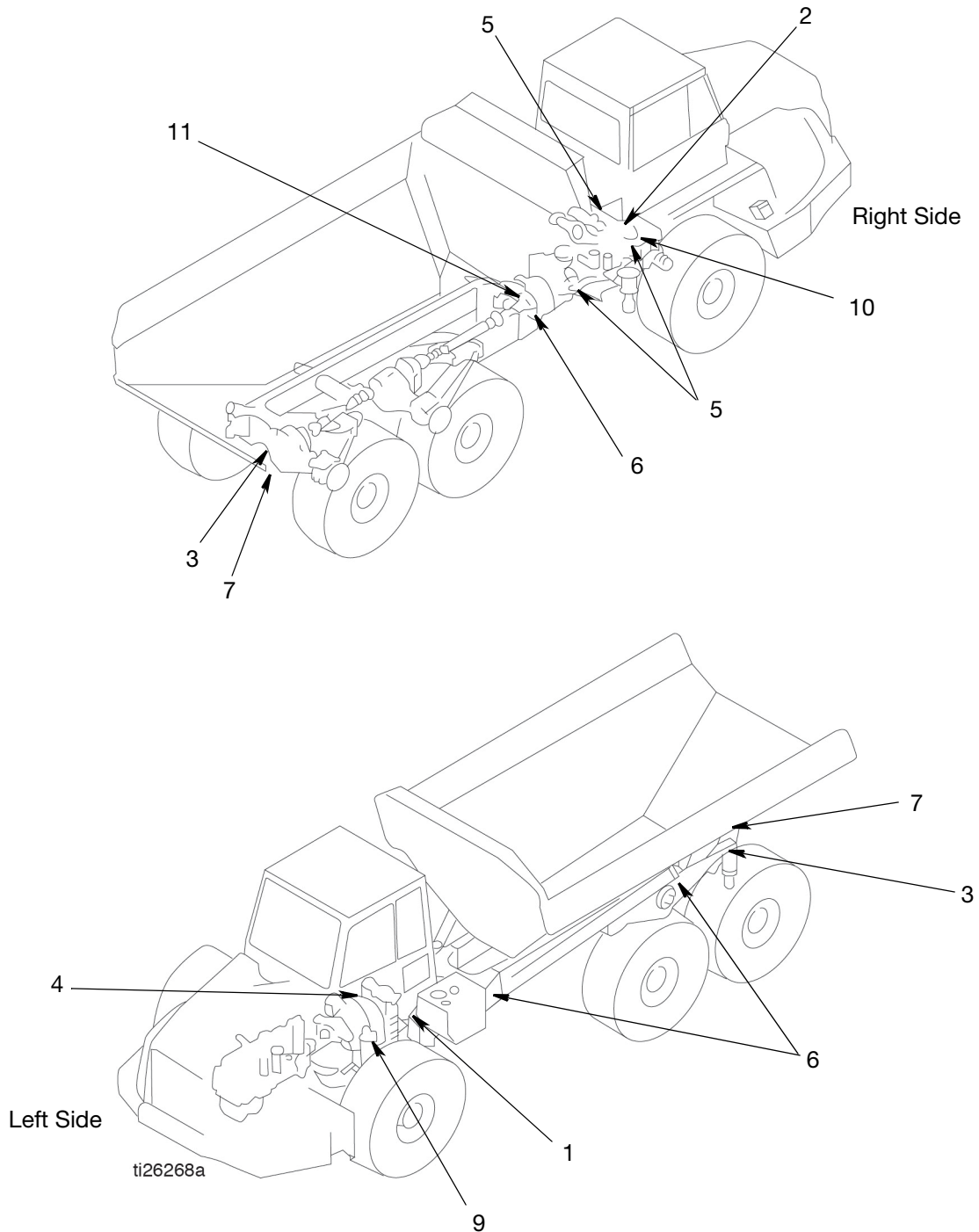
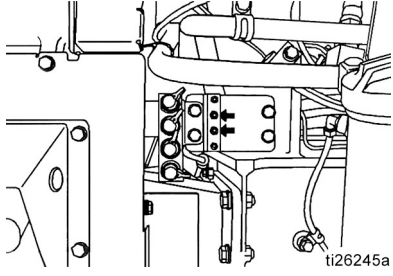
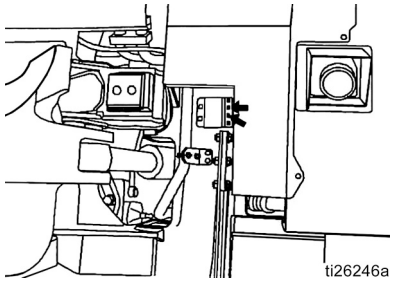
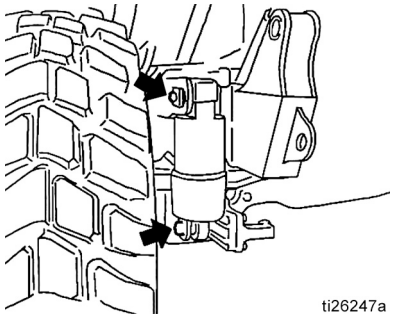
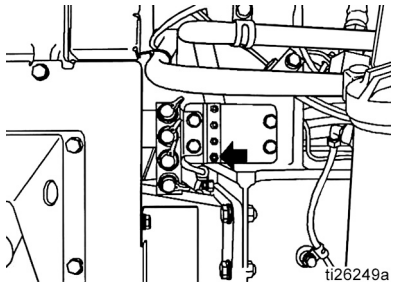
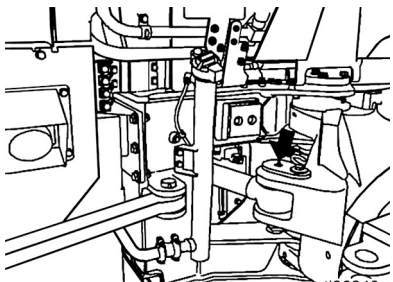
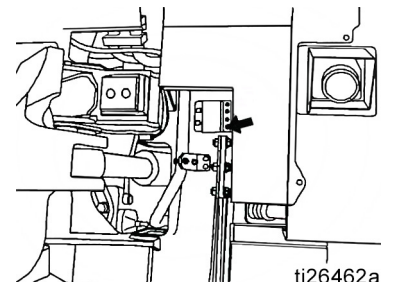
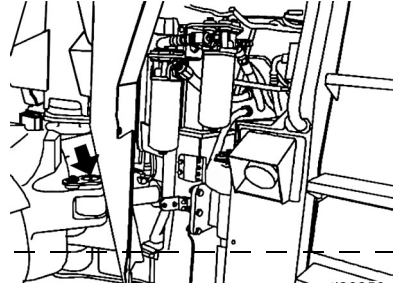

FIG. 1

HM300-5 Grease Point Fittings Table

Ref No.	Location		Part No.	Description
1	Front Suspension Left Side 2 places		17K061 555749	Street Elbow 1/8 inch x 4 JIC Straight
2	Front Suspension Right Side 2 places		17K061 555749	Street Elbow 1/8 inch x 4 JIC Straight
3	Rear Suspension Right and Left Sides 2 places each		17G422 556763	Short Extension 1/8 in. x 4 JIC 90° Elbow

NOTE: Photographs may include optional equipment.

4	Steering Cylinder Left Side 2 places		17K061 555749	Street Elbow 1/8 in. x 4 JIC Straight
			17G422 556763	Short Extension 1/8 in. x 4 JIC 90° Elbow
5	Steering Cylinder Right Side 2 places		17K061 555749	Street Elbow 1/8 in. x 4 JIC Straight
			17G422 556763	Short Extension 1/8 in. x 4 JIC 90° Elbow

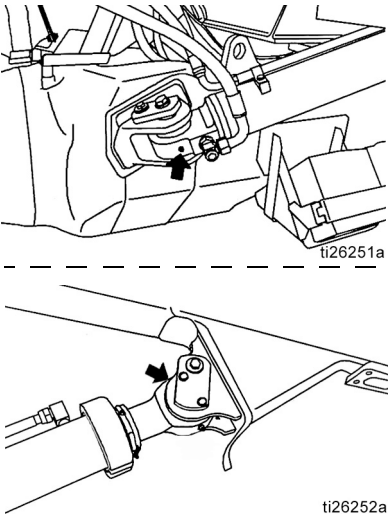
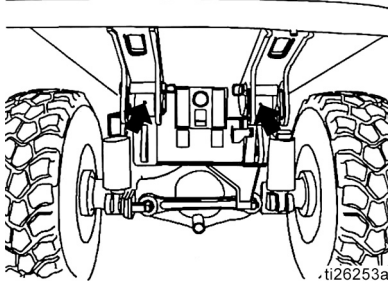
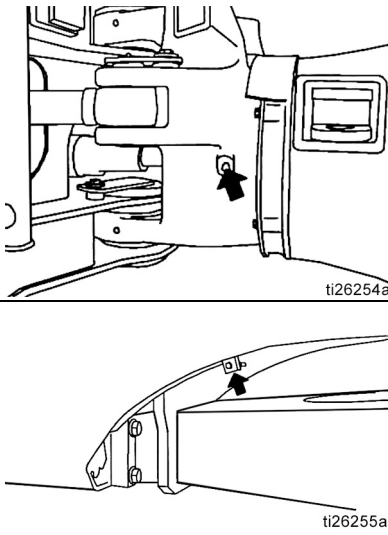
<p>6</p>	<p>Hoist Cylinder Right and Left Sides 2 places each</p>	 <p>NOTE: Orientation of dump body cylinder rod ends must be rotated 180-degrees</p>	<p>17K061 555749</p>	<p>Street Elbow 1/8 in. x 4 JIC Straight</p>
<p>7</p>	<p>Dump Body Hinge 2 places</p>		<p>17K061 555749</p>	<p>Street Elbow 1/8 in. x 4 JIC Straight</p>
<p>8</p>	<p>Hitch Bearing 2 places</p>		<p>17K062 556763 17G422 556763</p>	<p>Long Extension 1/8 in. x 4 JIC 90° Elbow Short Extension 1/8 in. x 4 JIC 90° Elbow</p>

Grease Point Fittings

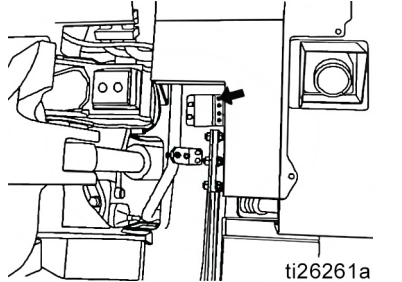
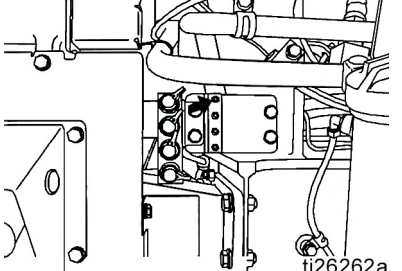
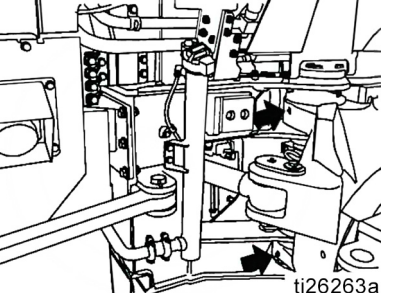
<p>9</p>	<p>Transmission Front Trunnion 1 place</p>		<p>17K061 555749</p>	<p>Street Elbow 1/8 in. x 4 JIC Straight</p>
<p>10</p>	<p>Transmission Rear Trunnion 1 place</p>		<p>17K061 555749</p>	<p>Street Elbow 1/8 in. x 4 JIC Straight</p>
<p>11</p>	<p>Center Hinge Pin 2 places</p>		<p>17G422 556763</p>	<p>Short Extension 1/8 in. x 4 JIC 90° Elbow</p>
<p>12</p>	<p>Tail Gate (optional) 2 places</p>		<p>556763 17K062</p>	<p>1/8 in. x 4 JIC 90° Elbow Long Extension</p>

HM400-5 Grease Point Fittings Table

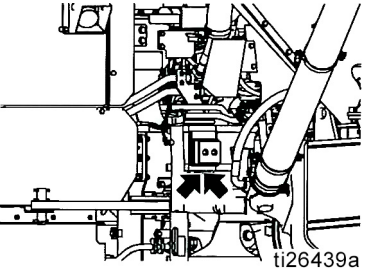
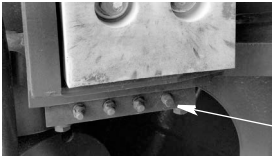
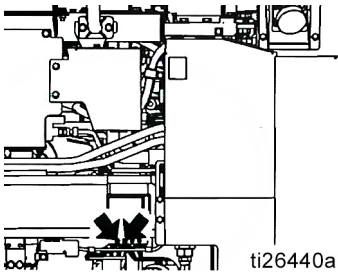
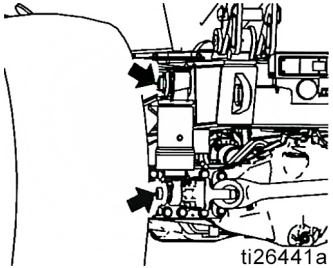
Ref No.	Location		Part No.	Description
1	Front Suspension Left Side 2 places	 <p>NOTE: Remove plug (p) before installing front suspension fittings.</p> 	17K062 15K783 555749 17K061 556762	<p>Lower Pin: Long Extension Street Elbow 1/8 in. x 4 JIC Straight</p> <p>Upper Pin: Street Elbow 1/8 in. x 4 JIC Straight</p>
2	Front Suspension Right Side 2 places		17K062 556762 555749 17K061 556762	<p>Lower Pin: Long Extension Street Elbow 1/8 inch x 4 JIC Straight</p> <p>Upper Pin: Street Elbow 1/8 in. x 4 JIC Straight</p>
3	Rear Suspension Right and Left Sides 2 places each		17G422 556763	<p>Left Side Upper: Short Extension 1/8 in. x 4 JIC 90° Elbow</p> <p>Left Side Lower: 1/8 in. x 4 JIC 90° Elbow</p>
			556763 17G422 556763 17K062 556763	<p>Right Side Upper: Short Extension 1/8 in. x 4 JIC 90° Elbow</p> <p>Right Side Lower: Long Extension 1/8 in. x 4 JIC 90° Elbow</p>

NOTE: Photographs may include optional equipment.

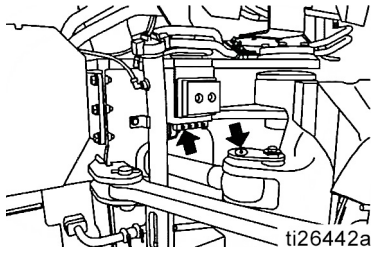
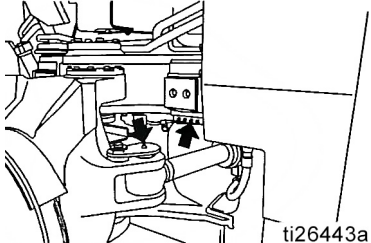
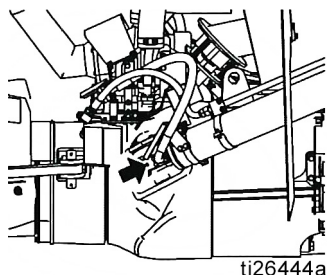
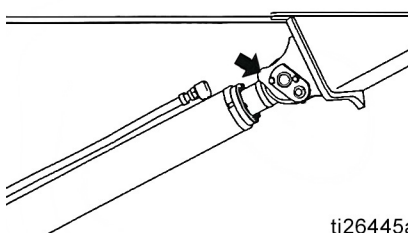
4	Steering Cylinder Left Side 2 places		17G422	On Rail: Short Extension Street Elbow 1/8 inch x 4 JIC Straight
			15K783 556762	
5	Steering Cylinder Right Side 2 places		17K062	On Rail: Long Extension Street Elbow 1/8 in. x 4 JIC 90° Straight
			15K762 556762	
6	Hoist Cylinder Right and Left Sides 2 places each		17K061	Street Elbow 1/8 in. x 4 JIC 90° Straight
			555749	
				
		<p>NOTE: Orientation of dump body cylinder rod ends must be rotated 180-degrees.</p>		

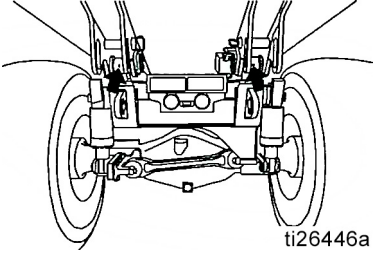
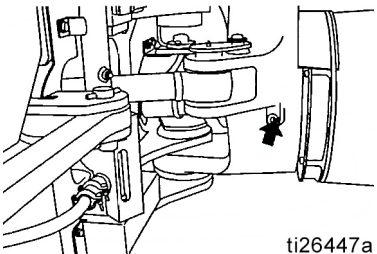
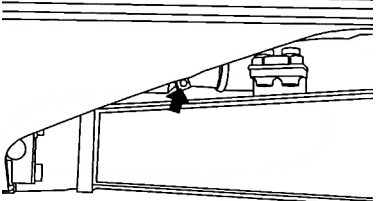
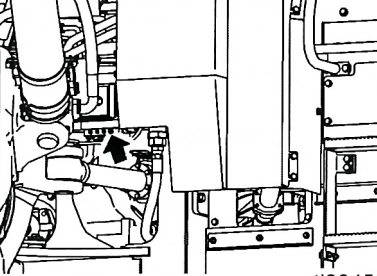
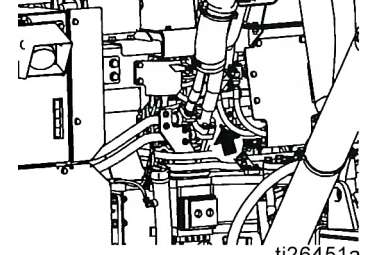
7	Dump Body Hinge 2 places	 <p>ti26446a</p>	17K061 555749	Street Elbow 1/8 in. x 4 JIC 90° Straight
8	Hitch Bearing 2 places	 <p>ti26447a</p>	17K062 556763	Long Extension 1/8 in. x 4 JIC 90° Elbow
		 <p>ti26448a</p>	17K061 555749	Street Elbow 1/8 in. x 4 JIC 90° Straight
9	Transmission Front Trunnion 1 place	 <p>ti26450a</p>	17G422 555749	Short Extension 1/8 in. x 4 JIC Straight
10	Transmission Rear Trunnion 1 place	 <p>ti26451a</p>	17K061 555749	Street Elbow 1/8 in. x 4 JIC Straight

Grease Point Fittings

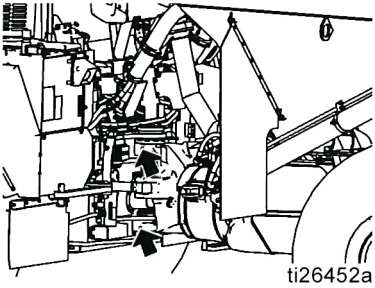
11	Center Hinge Pin 2 places	 <p>ti26452a</p>	17G422 556763	Short Extension 1/8 in. x 4 JIC 90° Elbow
12	Tail Gate (optional) 2 places		15K062 556763	Long Extension 1/8 in. x 4 JIC 90° Elbow

MSP Divider Valve Assembly

The Divider Valve Assembly includes the following components:

- MSP divider valve base
- MSP divider valve assembly
- 1/8 in. x 4 JIC straight outlet fittings
- Inlet fittings
- Cycle indicators
- Performance indicators
- Proximity switches

Prepare a clean, flat area to assemble the valves.

MSP Valve Component Identification

NOTE: The MSP Divider Valves shown in FIG. 2 - FIG. 8 are provided for reference only. The MSP Divider Valves used in your installation may include fewer or more blocks and appear slightly different than those shown in the reference figures.

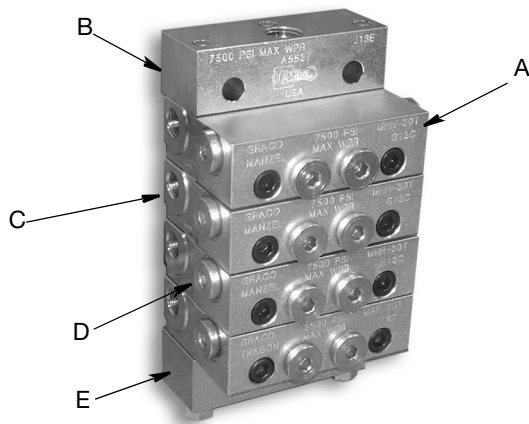

FIG. 2

Key:

- A Valve Section
- B Inlet Section
- C Indicator / Port Plug
- D End Plug
- E End Section

MSP Divider Valve Assembly

1. The MSP Divider Valves require assembly (FIG. 3).

NOTE: Refer to the MSP Divider Valve Assembly Table and MSP Divider Valve and Lube Points Assembly reference illustrations, FIG. 11 - FIG. 14 (page 20), to verify assembly orientation.

- a. Remove components from packaging.
- b. Assemble metering valves to base plates as shown in FIG. 3.

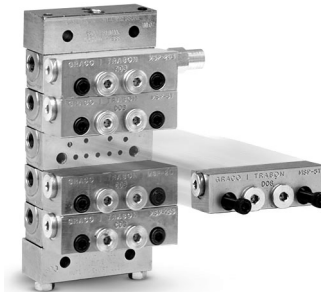

FIG. 3

2. Install inlet fitting assembly in ports (FIG. 4).

- Inlet fitting assembly includes: a 1/4 inch tee, a 1/4 x 4 JIC and a zerk fitting
- Orient zerk fitting so it is always easily accessible (see FIG. 4 and FIG. 5).



FIG. 4

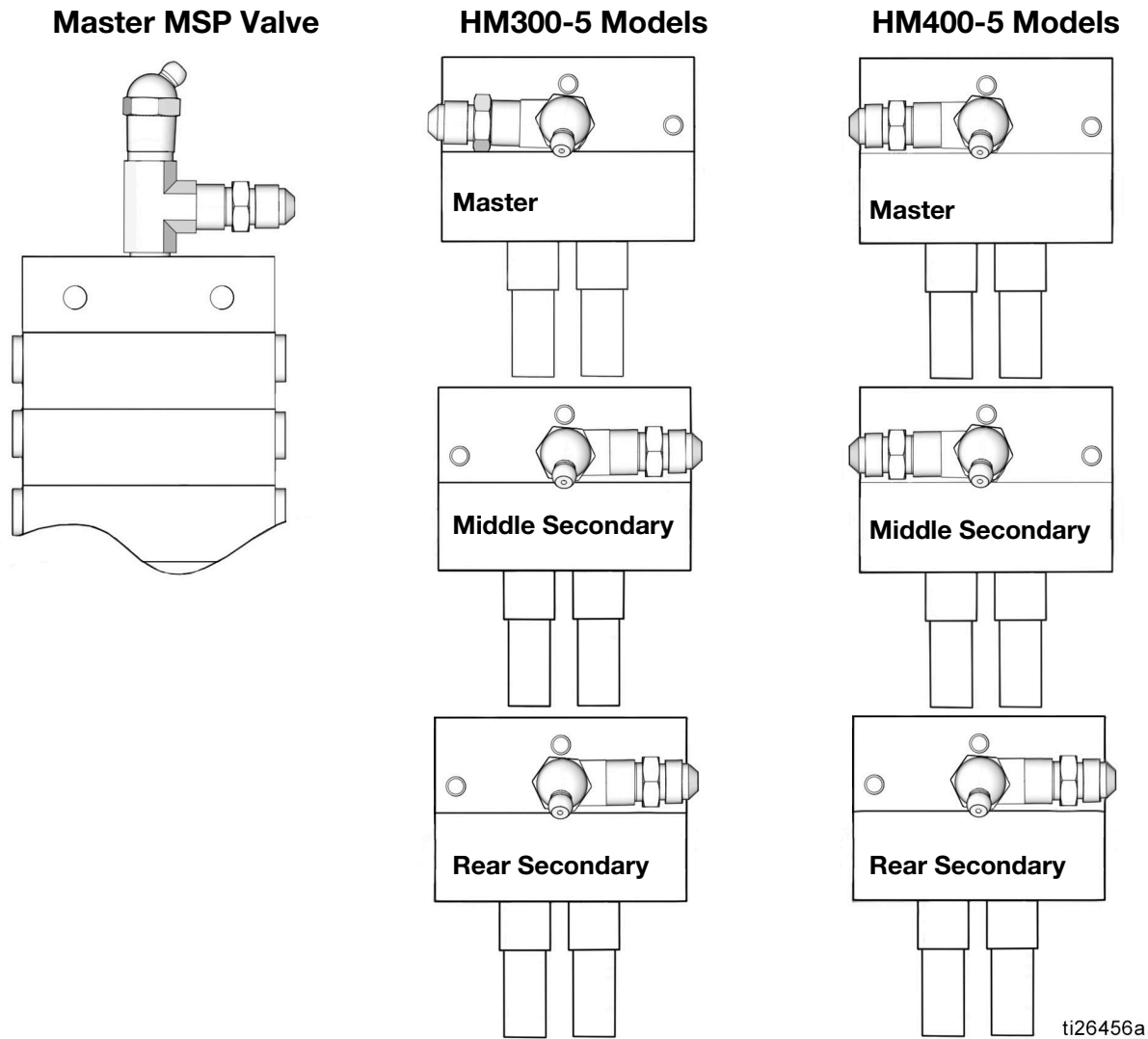

FIG. 5: Zerk Orientation

3. Install grease zerk fittings and zerk cover (FIG. 6).

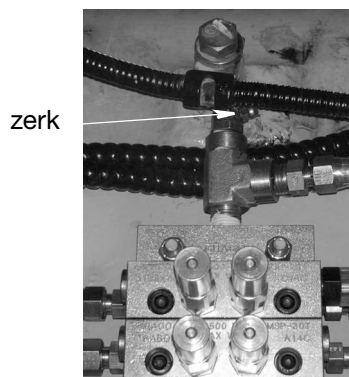

FIG. 6

4. Remove end plugs and indicator port plugs before installing performance and cycle indicators in the MSP Divider Valve assembly.

5. Install performance indicators in ports (FIG. 7):

- 2000 psi (13.79 MPa, 137.9 bar) master indicators are installed in the master valve (quantity 10).
- 1000 psi (6.89 MPa, 68.95 bar) secondary indicator are installed in the secondary valve (quantity 18).

NOTE: Refer to the MSP Divider Valve Assembly Location Table (page 20) to verify assembly orientation.

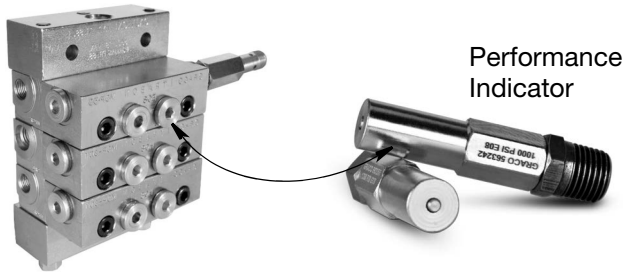

FIG. 7

6. Install cycle indicators into secondary valves (FIG. 8).
 - Magnetic Cycle indicators (quantity 2)

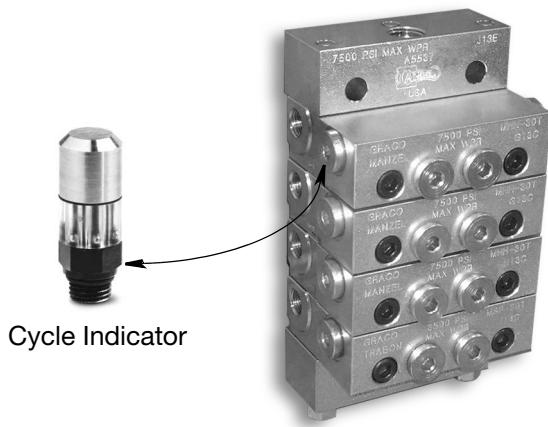

FIG. 8

7. Install the Proximity Switch to MSP Master/Secondary Divider Valve (FIG. 9).

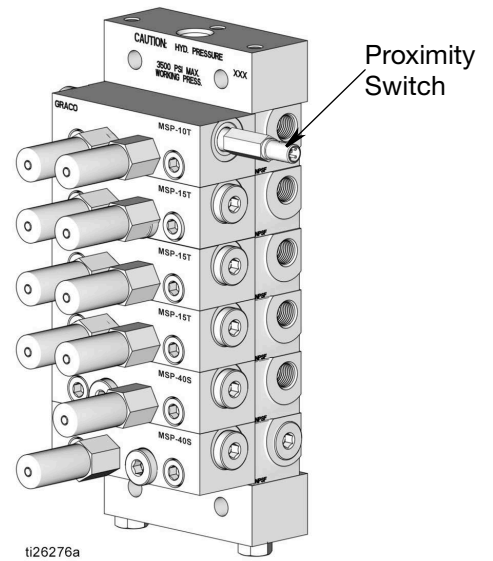

FIG. 9

8. Install outlet plugs in all open ports as shown in the MSP Divider Valve Assembly reference illustrations (FIG. 11 - FIG. 14) on page 20.
9. Install outlet fittings in all ports (FIG. 10).
 - All outlets use 1/8 in. x 4 JIC straight fittings (included in kit).

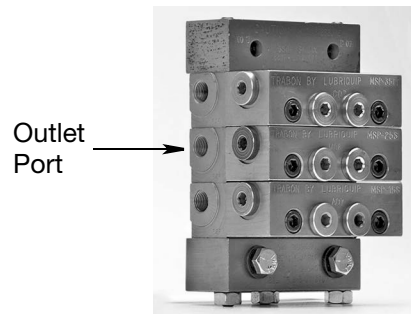
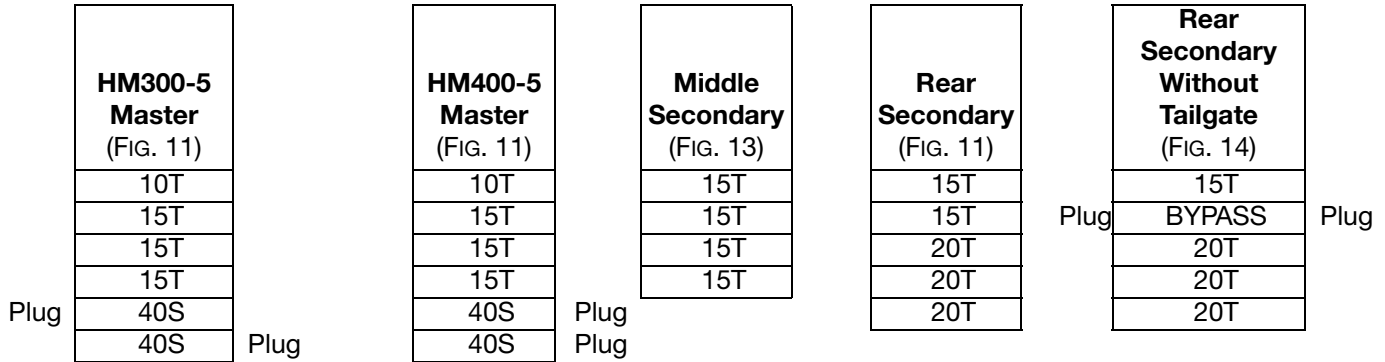

FIG. 10

MSP Divider Valve Assembly



MSP Divider Valve and Lube Points Assembly

Master Valve Assembly (FIG. 11)

Middle Secondary (FIG. 13)

HM300-5

HM400-5

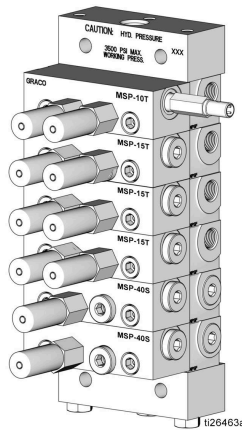
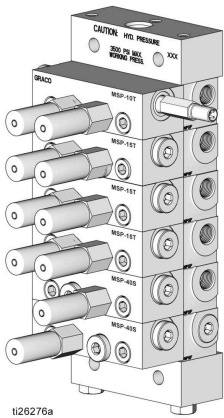

FIG. 11

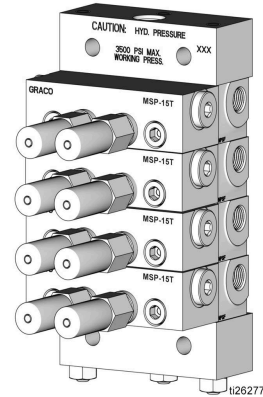

FIG. 13

Rear Secondary: With Tailgate Lubrication (FIG. 12)

Secondary: No Tailgate Lubrication (FIG. 14)

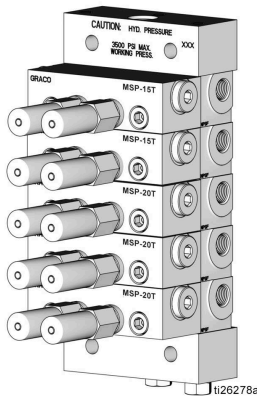

FIG. 12:

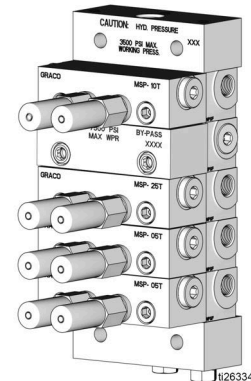

FIG. 14:

Weld Studs

General Information

NOTE:

- Weld studs are provided in the installation kit. However, the installer may use their own weld studs if preferred.
- Specific Weld Stud installation instructions and related dimensions are provided in the related installation instructions.

NOTICE

To avoid damaging the equipment, consult the Komatsu operations and maintenance manual before welding.

1. Dump Bed Guards and P-Clamps: Use the dimensions provided in the table on Page 23 to determine the location of the first weld stud. Then use the guards to determine the installation locations for the remaining weld studs on the dump bed.
2. Use a marker or paint pen to mark the weld stud locations.
3. MSP Divider Valve Weld Studs: Use the instructions and dimensions provided in the MSP Divider Valve Installation instructions beginning on page 24 to determine the location of the first weld stud. Then use the mounting holes in the MSP Divider Valve assemblies to determine the installation locations for the remaining weld studs.
4. Use a marker or paint pen to mark the weld stud locations.
5. Adjust the installation locations for MSP Divider Valves, Guards and P-clamps as needed before spot welding the weld studs.
6. Clean the surface as needed to prepare it for welding.
7. Spot weld studs.
8. Clean the weld with a flap disk or grinding disk.
9. Prime the weld surface with Komatsu primer. When primer has dried, apply a few coats of matching Komatsu colored paint.

Dump Body Guards

NOTE: The Guards provided in your kit are designed for use on various sizes of Komatsu equipment. For some installations they may need to be trimmed to the correct size before installation. This should be one of the first steps performed in the installation procedure to ensure there is sufficient time for primer and paint to dry before installing the Guards on the equipment.

1. Use a cutting tool to trim the Guards to a finished length of 50 inches (1270 mm) for the HM300-5 models as shown in FIG. 15. For HM400-5 models, **DO NOT CUT** the guards.

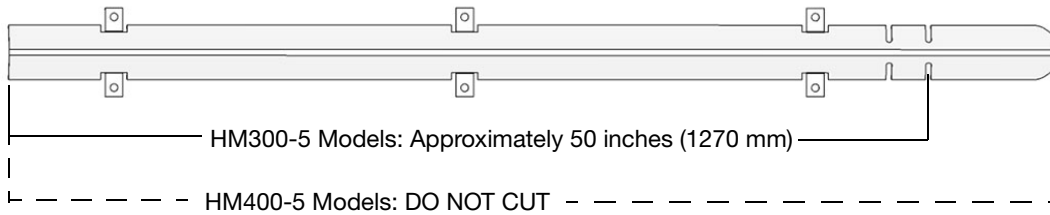

FIG. 15

2. Clean and debur the cut edge.
3. Prime the Guarding with Komatsu primer. When primer has dried, apply a few coats of matching Komatsu colored paint.

Dump Body Guards Weld Stud Dimensions

Install weld studs to the each side of the dump body. Use the dimensions provided in the table below to determine the installation location of each Weld Stud. After the location of the first weld stud is determined, place the Guard on the side of the dump body and use it to mark the location for the remaining weld studs. (See FIG. 16 and FIG. 17).

	A (FIG. 16)		B (FIG. 16)		C (FIG. 17)		D (FIG. 17)	
Model	inches	mm	inches	mm	inches*	mm	inches*	mm
HM300-5	10.0	254	31.0	787.4	2.0	25.4	3.0	76.2
HM400-5	10.0	254	31.0	787.4 <td 2.0	25.4	3.0	76.2	

*Measurement C applies to both ends of the Guard and is taken from the end of the Guard.

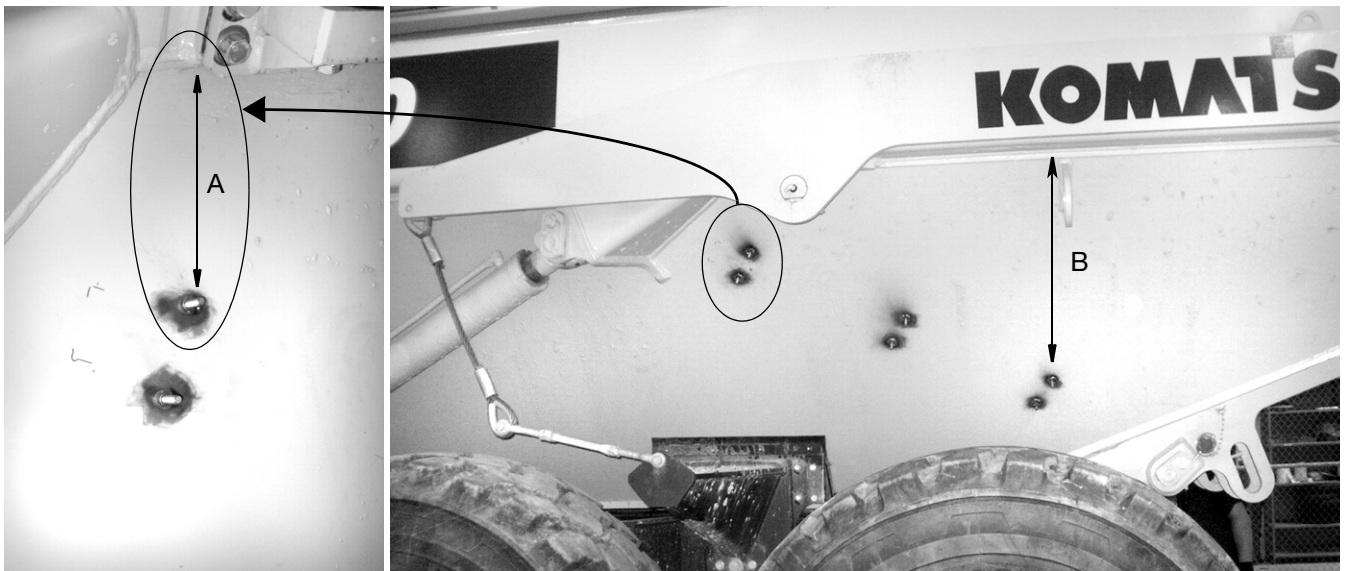

FIG. 16



FIG. 17

Weld Stud and MSP Master Divider Valve Installation

Master Divider Valve Installation

1. Remove the bolts securing the cab access panel to the equipment as shown in FIG. 18. Keep the bolts to reinstall panel to the equipment.

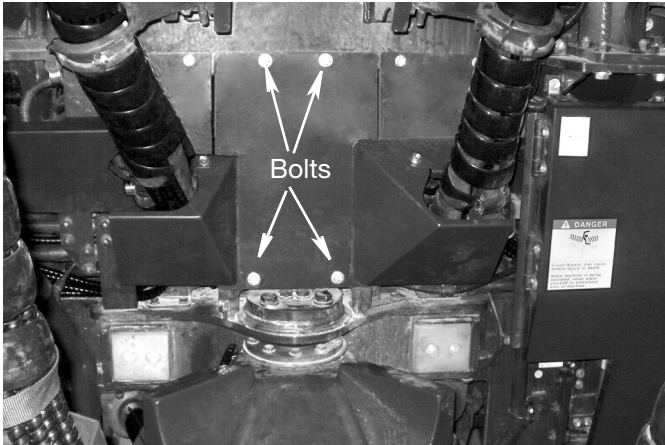

FIG. 18: HM300-5

Model	E		F	
	inches	mm	inches	mm
HM300-5	centered FIG. 19		1.75	266.7
HM400-5	centered FIG. 23		4.0	101.6

2. **HM300-5 Models:** Center the Master Divider Valve (left to right) on the access panel and 1.75 inches (44.45 mm) from the top of the panel as shown in FIG. 19 and FIG. 22.

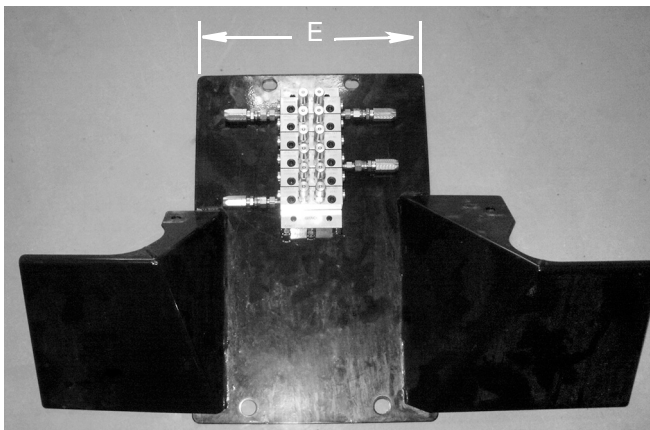

FIG. 19: Center Master Divider Valve on Panel

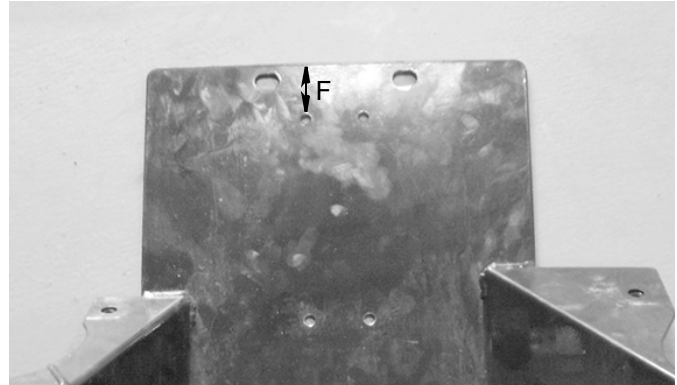

FIG. 20

3. Mark the Master Divider Valve mounting hole locations. Set the Master Divider Valve aside. Drill holes where marked.
4. Install Master Divider Valve to panel using bolts included in the kit (FIG. 21).

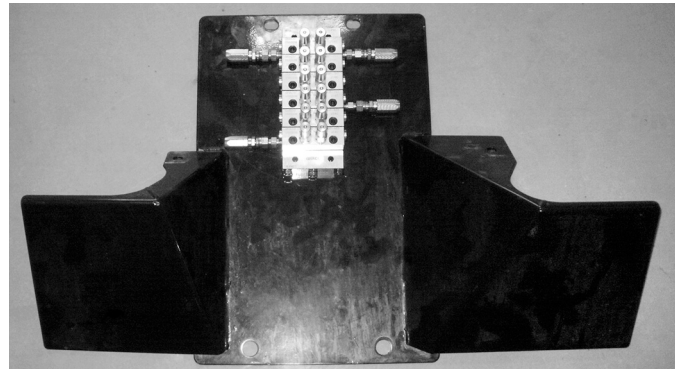

FIG. 21

5. Use the 4 bolts removed in Step 1 to reinstall the panel on the equipment. Tighten bolts securely.

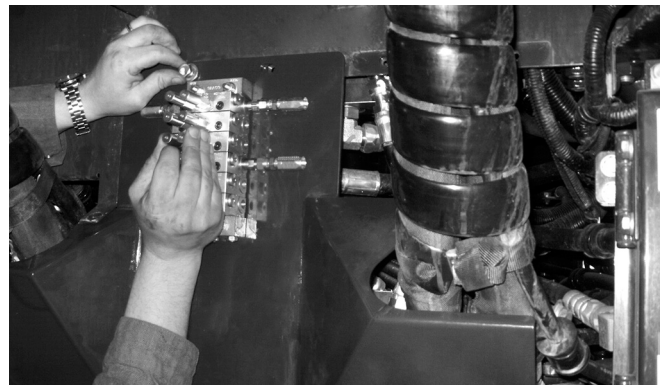

FIG. 22

2. **HM400-5 Models:** Center the Master Divider Valve (left to right) on the access panel and 4 inches (101.6 mm) (F) from the top of the panel as shown in FIG. 23 and FIG. 24.

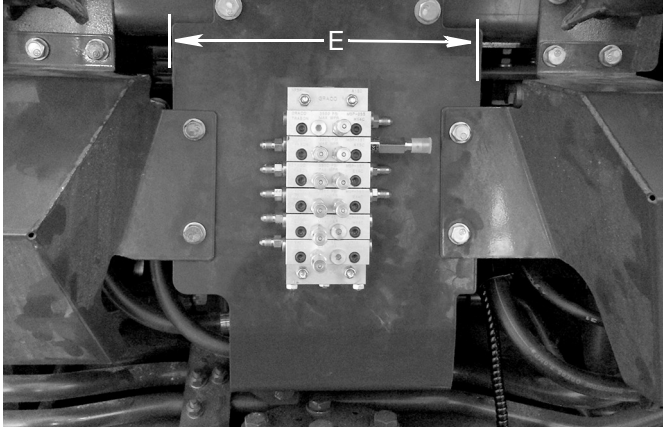

FIG. 23: Center Master Divider Valve on Panel

3. Mark the Master Divider Valve mounting hole locations. Set the Master Divider Valve aside. Drill holes where marked.
4. Install mounting bolts through the holes from the back of the panel. Tighten 1/4 - 20 nuts over bolts

as shown in FIG. 24. The nuts will act as spacers to shim the valve out and provide additional hose clearance.

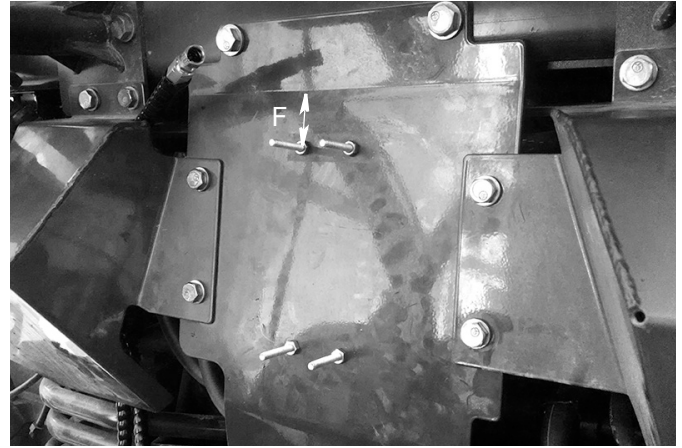

FIG. 24

5. Install Master Divider Valve to panel using bolts installed in Step 4.
6. Use the bolts removed in Step 1 to reinstall the panel on the equipment. Tighten bolts securely.

Middle and Rear Secondary MSP Divider Valves and Weld Stud Dimensions

Model	G		H		J		K	
	inches	mm	inches	mm	inches	mm	inches	mm
HM300-5	27.0	685.8	5.0	127.0	10.5	266.7	2.5	63.5
HM400-5	20.0	508.0	7.0	177.8	14.0	355.6	2.5	63.5

1. Raise the dump body to the fully up position. See this procedure in the Komatsu operation and maintenance manual.
2. For the HM400 models only: The Middle secondary MSP Divider Valve weld studs are installed to the inside of the dump body frame bracing on the left side of the machine.

NOTE: To locate the first weld stud, for dimension G measure from the front of the right side rail and for dimension H measure down from the top of the rail (FIG. 25 - FIG. 27). See Middle and Rear Secondary MSP Divider Valves and Weld Stud Dimensions



FIG. 25: HM300-5

Table, page 26.



FIG. 26: HM300-5

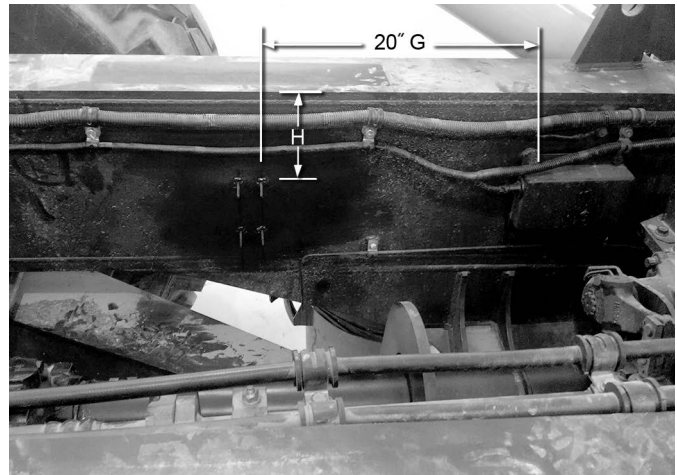

FIG. 27: HM400-5

3. Use the MSP Divider Valve assembly to determine the locations of the remaining mounting holes. Mark each hole and make any minor location adjustments before installing the weld studs.
4. Install weld studs where marked.
5. For the Rear Secondary MSP Divider Valve, the weld studs are installed on the inside of the dump bed rear frame bracing as shown in FIG. 28- FIG. 29.

NOTE: To locate the first weld stud, for dimension J measure from the bottom of the dump body frame rear frame bracing and for dimension K measure from the bottom of the dump body frame cross brace. See Middle and Rear Secondary MSP Divider Valves and Weld Stud Dimensions table, page 26. Use the MSP Divider Valve assembly to determine the locations of the remaining mounting

holes. Mark each hole and make any minor location adjustments before installing the weld studs.

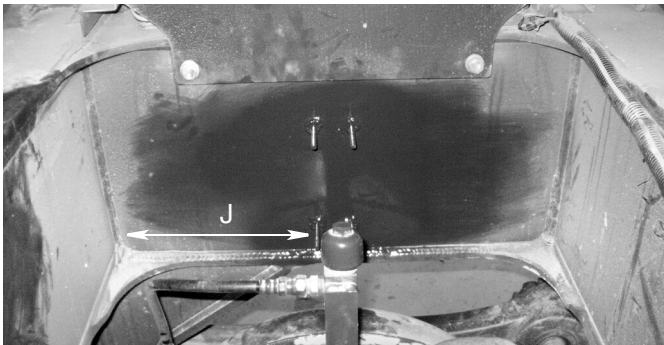

FIG. 28

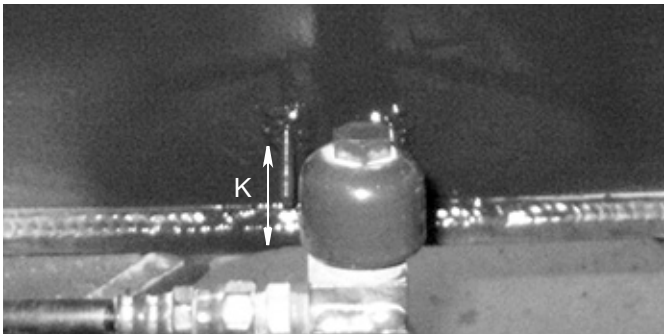

FIG. 29

6. Install the Middle and Rear Secondary MSP Divider Valves to the weld studs using the supplied 1/4-20 lock nuts. See FIG. 30 and FIG. 31.

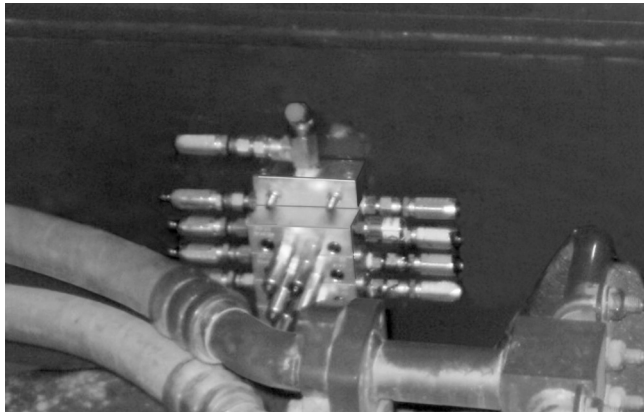

FIG. 30: Middle Secondary Divider Valve

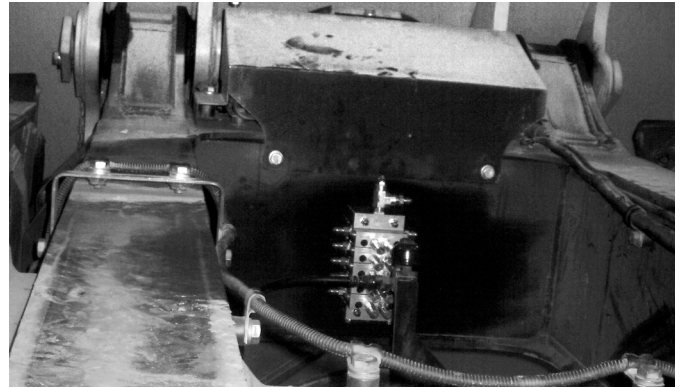

FIG. 31: Rear Secondary Divider Valve

G3 Pump

The G3 Pump includes the following components:

- Pump with attached reservoir
- Pressure relief valve (required to protect system from damage)
- Pressure gauge (used to monitor system performance and to assist with troubleshooting).
- Mounting bracket and hardware
- CPC power cable
- Zip ties
- Spacers - 4 total
- Washers - 4 total
- Nuts - 4 total

1. Remove all components from the packaging and place all parts on a clean, flat surface.



FIG. 32

2. Assemble the pressure relief valve.
 - a. Apply thread sealant (user supplied) to threads of pressure relief valve (a) (FIG. 33).

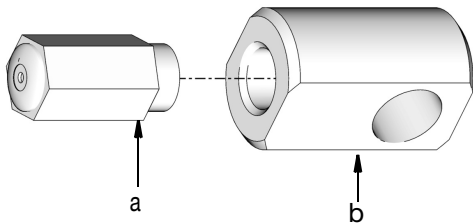

FIG. 33

- b. Install pressure relief valve (a) into banjo fitting (b). Wrench tighten (FIG. 33).
- c. Install one washer (c) over end banjo bolt (d). Then install banjo fitting (b) on banjo bolt, followed by the second washer (c) (FIG. 34).

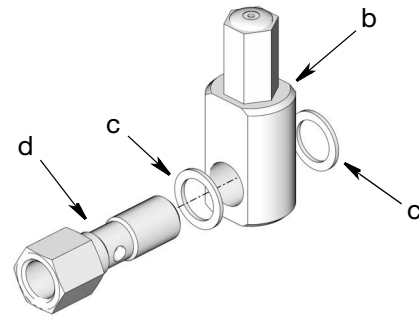

FIG. 34

3. Install banjo bolt (d) into pump element (e) (FIG. 35).

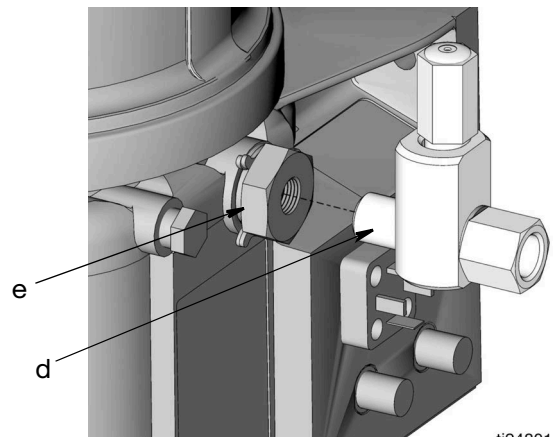

FIG. 35

4. Use two wrenches to tighten banjo fitting. Place one wrench on the pump element (e) and the second wrench over the end of the banjo bolt (d). ONLY tighten the banjo bolt (d) while holding the pump element (e) securely in place. Torque banjo bolt (d) to 35 ft. lbs (45.7 N•m) (FIG. 36). Take care to not over-tighten.

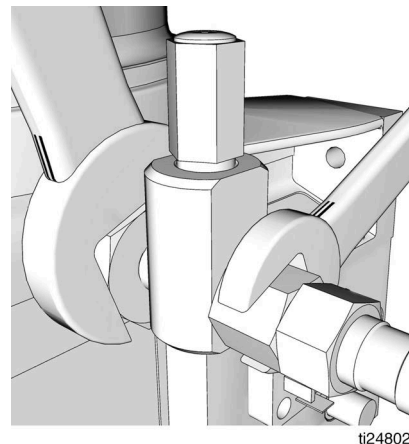

FIG. 36

5. Install the pressure gauge fitting, pressure gauge and outlet fitting in the pressure relief valve as shown in FIG. 37.

NOTE: Hold the pressure relief valve securely in place while installing the pressure gauge assembly.

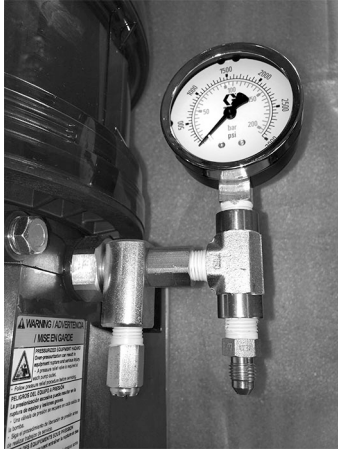

FIG. 37

Installing the G3 Pump to the Filter Cover

HM300-5 Models

1. Tilt the cab back. See this procedure in the Komatsu operation and maintenance manual.



FIG. 38

2. Remove the bolts from the yellow filter cover and remove the cover from the equipment (FIG. 39). Keep these bolts to reinstall filter cover to equipment.



Bolts



FIG. 39

3. Square up and align the adapter bracket (a) to the narrow end of the filter cover (b) as shown in FIG. 40. Mark the locations of the mounting holes (c) on the bracket. Drill holes through the filter cover.

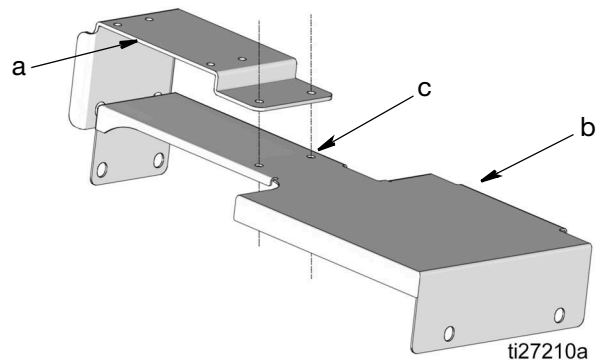

FIG. 40

4. Use the supplied hardware to install the G3 pump to the G3 pump mounting bracket (d). Tighten securely.
5. Use the supplied 5/16 inch mounting hardware to install the G3 pump mounting bracket (d) to the adapter bracket (a) as shown in FIG. 41. Tighten securely.

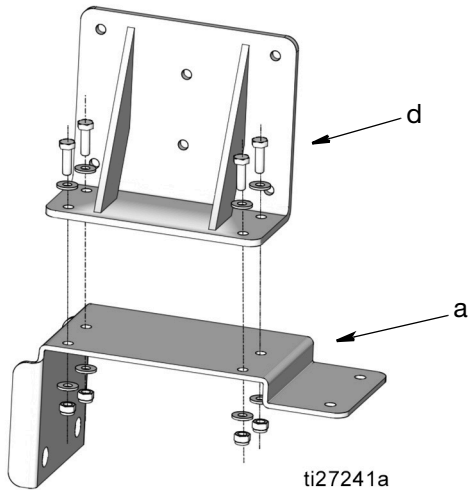

FIG. 41

6. Use the supplied 3/8 inch mounting hardware to install the adapter bracket assembly (a) to the filter cover (b) through the mounting holes (c) drilled in Step 3, page 29.

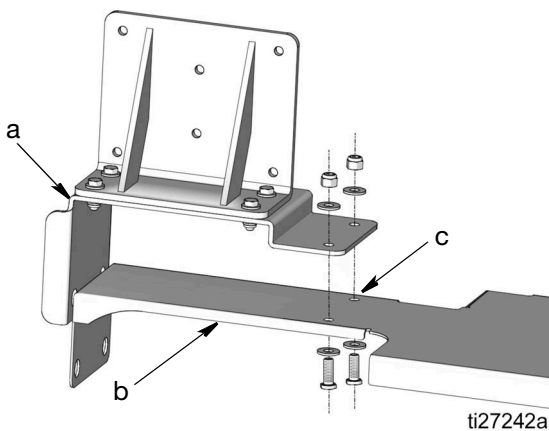

FIG. 42

7. Reinstall filter cover with the G3 pump installed on it, using the 4 bolts removed in Step 1.



FIG. 43

HM400-5 Models

1. To determine the location of the first mounting hole, measure 3.75 inches (95.25 mm) from the inside rear corner and 1.25 inches (31.75 mm) from the rear outer edge of the filter cover as shown in FIG. 44. Mark the location of the first hole. Align the hole in the base of the bracket with the hole.

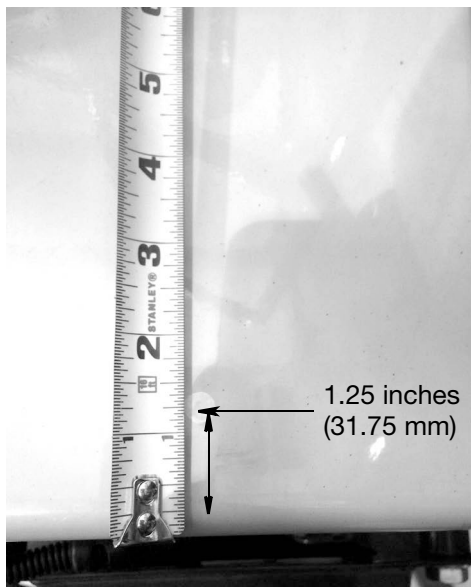
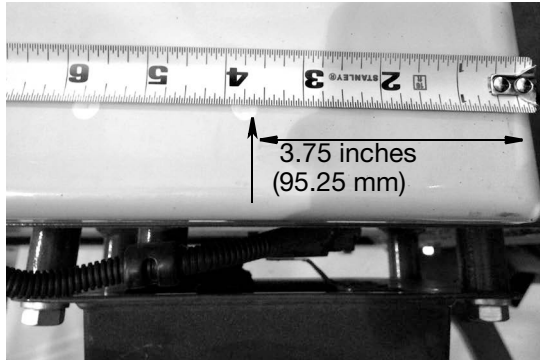

FIG. 44

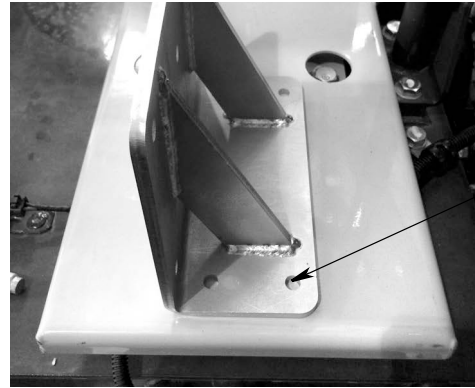

FIG. 45

2. Drill to drill the holes through the bracket.
3. Insert bolts through holes and then position the G3 mounting plate on the bracket. Install nuts over the end of the bolts and tighten securely.

Remote Fill Installation

Remote Fill Parts

Ref*	Part No.	Description	Qty
16	556762	CONNECTOR, #4, JIC, 1/4 PM	1
45	557950	BULKHEAD, remote fill	1
46	100840	FITTING, elbow, 1/4 in., street	1
47	557896	STUD, fill, 1/4 inch NPTF (f)	1
48	556408	FITTING, 1/4 x 1/8 inch NPTF Hex	1
49	555749	CONNECTOR, #4, JIC, 1/8 PM	1
50	15K783	FITTING, elbow	1

*See Parts, page 65.

Instructions

Remote Fill Mounting Dimensions

Model	A		B	
	inches	mm	inches	mm
HM300-5	4.75	120.6	1.0	25.4
HM400-5	3.0	76.2	1.5	38.1

1. Remove the 2 bolts holding the access panel located on the left side of the equipment, behind the cab and remove access panel. Keep the bolts for reinstalling the panel to the truck.

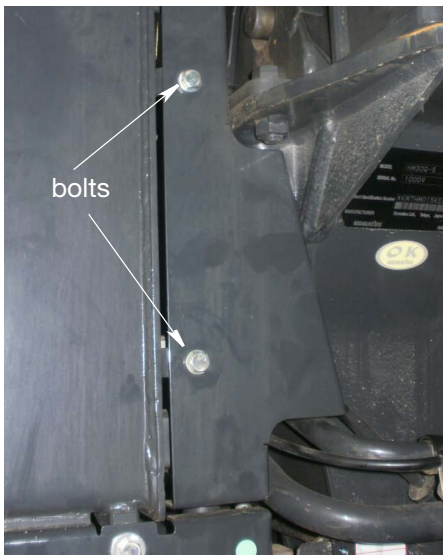

FIG. 46

2. **HM300-5 Models:** Drill a hole to install the remote fill to the panel. Center the hole between the existing two bolt holes (approximately 4.75 inches (120.6 mm) down from the top hole) and 1.0 inch (25.4 mm) in from the outer, flat edge (FIG. 47).

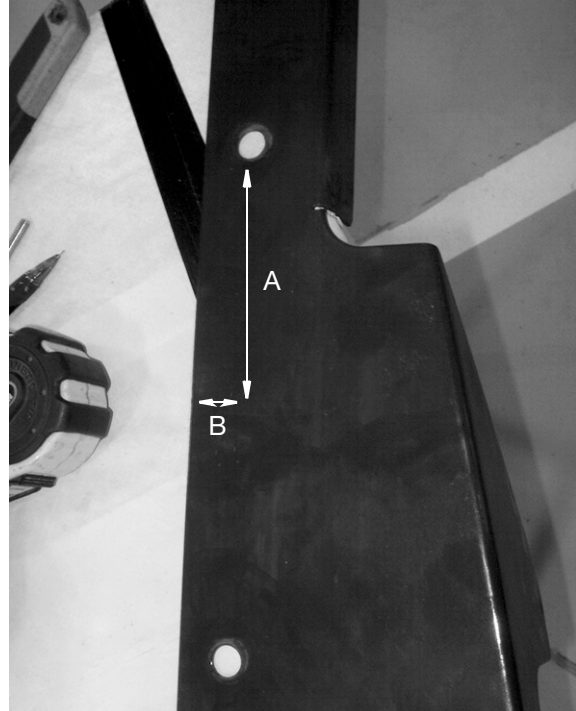

FIG. 47: HM300-5

- HM400-5 Models:** Drill a hole to install the remote fill to the panel. The hole should be placed approximately 3.0 (76.2 mm) from the bottom of the panel and 1.5 (38.1 mm) from the left edge of the panel as shown in FIG. 48.



FIG. 48: HM400-5

3. Connect one end of the remote fill hose to the G3 pump.
4. Route the hose between the G3 pump and remote fill along a path under the filter bracket and behind the cab to the remote fill as shown in FIG. 49.

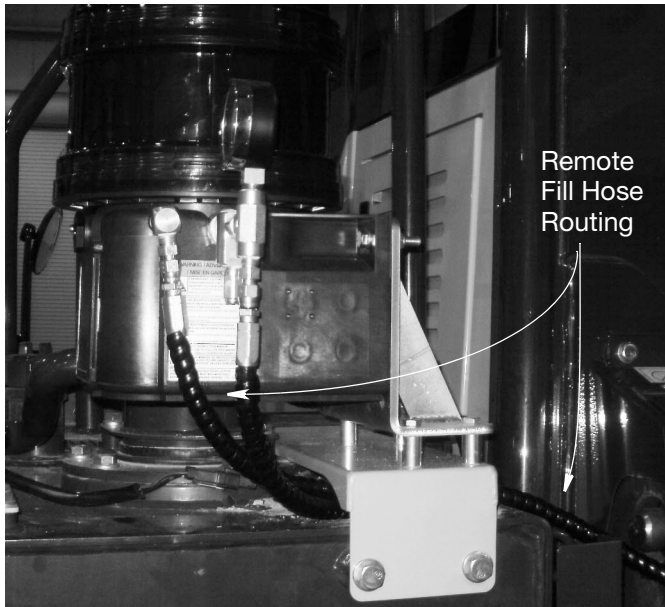

FIG. 49

5. Trim the hose to the necessary length.
6. Apply thread sealant to threads of connector (49). Install bulkhead fitting (45) to the connector (49). Remove mounting nut.

7. Install bulkhead fitting (45) through bulkhead hole drilled in Step 1. Reinstall mounting nut over end of bulkhead fitting to secure bulkhead fitting to the truck (FIG. 50).

NOTE: When installing the bulkhead fitting (45) make sure connector (49) is oriented upward as shown in FIG. 50

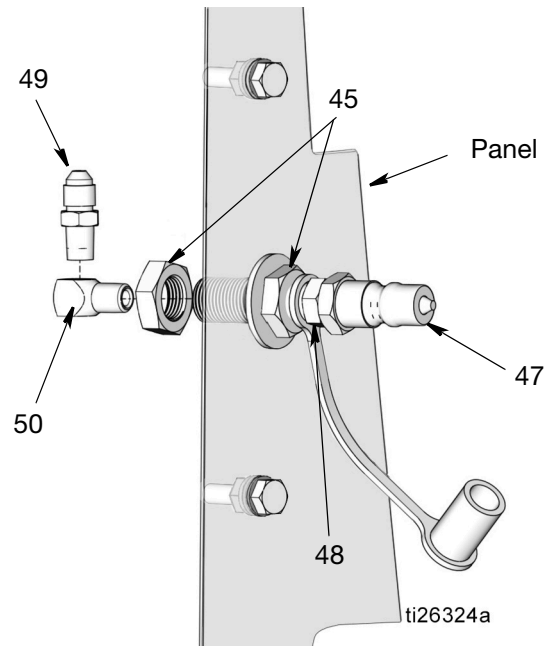

FIG. 50

8. Join connector (49) to end of remote fill hose.
9. Apply thread sealant to I.D. threads of bulkhead fitting (45) and to threads of coupler (48). Install coupler to the bulkhead fitting. Tighten securely.
10. Install panel removed in Step 1.

11. Connect fill stud (47) to coupler (48). Tighten securely.

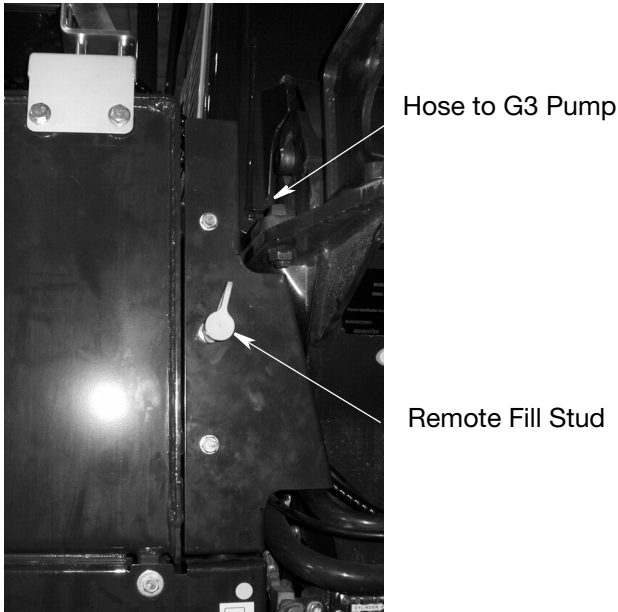

FIG. 51: Remote Fill Stud installed on HM300-5



FIG. 52: Remote Fill Stud installed on HM400-5

Installing and Routing G3 Power Cable

1. Discard the G3 pump CPC power cable (included with the G3 pump).

NOTE: This power cable has an angled connector.

2. Wrap the 15 foot power cable with the straight connector, (part no. 126218) with the 1/4 in. cable loom.
3. Connect the end of the power cable to the G3 pump.
4. Route the power cable through the mounting bracket as shown in 53.

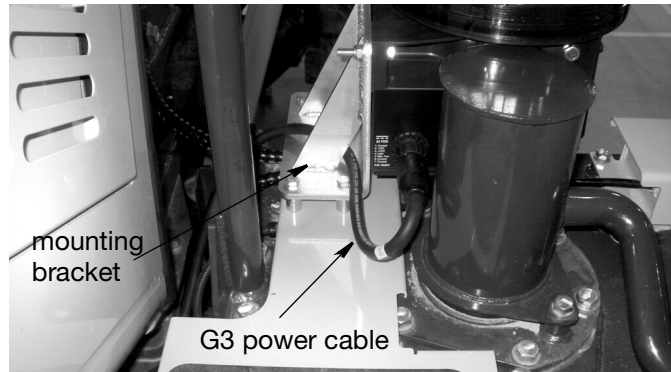

FIG. 53

5. Route the power cable under the cab to the driver's side. Follow the same path used to route the equipment's existing hoses and cables secured to the bottom of the cab as shown in FIG. 56.

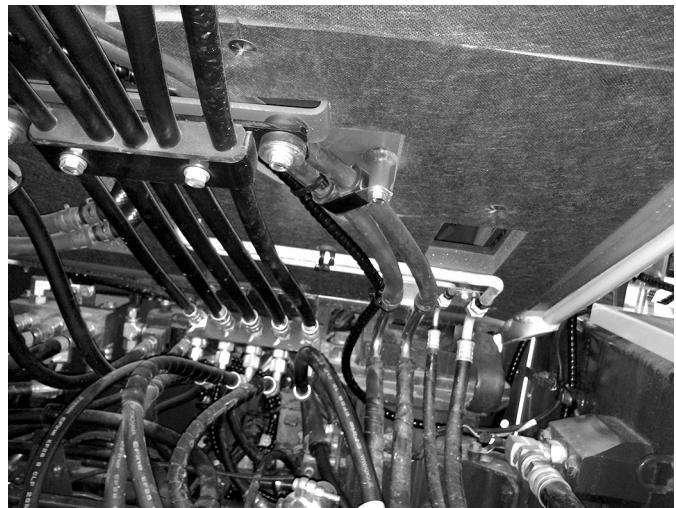

FIG. 54

NOTE: The white dotted line in FIG. 55 shows the power cable routing path toward the back of the machine.

7. DO NOT feed the cable through the grommet at this time. It will be wrapped in 1/4 inch cable loom with the Proximity Switch Cable and fed through the grommet as a single cord.

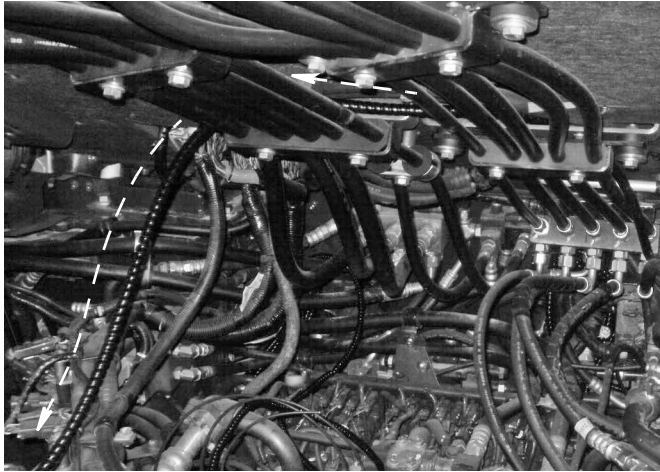

FIG. 55

Power Cable



FIG. 56

6. Cut a criss-cross pattern in the grommet membrane in the cab floor (FIG. 57). Make the cut just large enough to feed the power cable through it.



FIG. 57

Proximity Switch Cable

The proximity switch is used to monitor the system.

1. Wrap the proximity switch cable with the 1/4 in. cable loom.
2. Install the proximity switch to the Master Divider Valve as shown in FIG. 58.

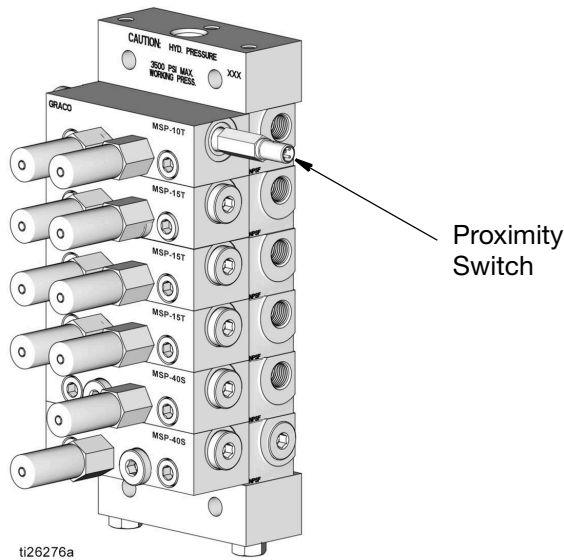

FIG. 58

3. Route cable under the cab. Follow the same path used to route the equipment's existing hoses and cables.

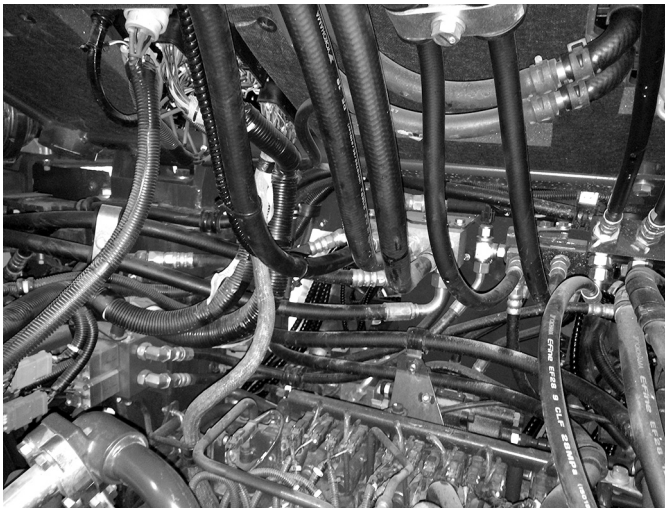

FIG. 59

4. Join it to the same path as the G3 pump power cable and use the heavy duty zip ties (included in the kit) to secure the proximity cable to the G3 pump cable. Wrap the proximity cable and G3 pump cable together to create a single cord (FIG. 60).

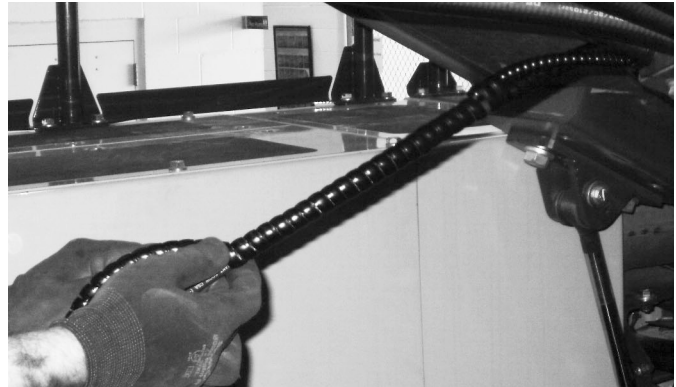

FIG. 60

5. Route the cable bundle through the rubber grommet in the floor of the cab (prepared in Step 6, page 35) (FIG. 61) and into the cab under the floor mat near the accelerator pedal (FIG. 62).

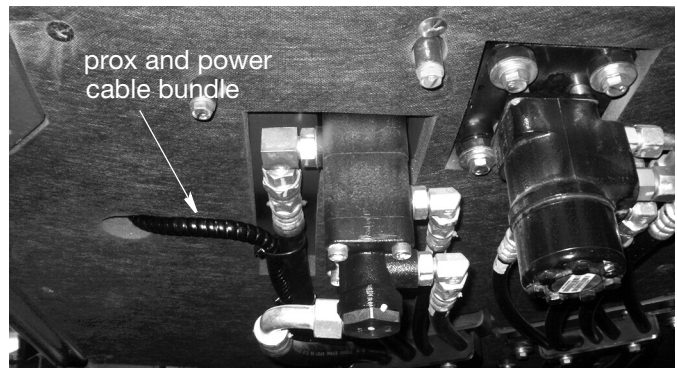

FIG. 61: View below cab



FIG. 62: View inside cab under floor mat

GLC2200 Controller Wiring

NOTICE

To avoid damaging the truck:

- Turn off and disconnect power at the battery before installing equipment.
- All electrical wiring must be done by a qualified professional or Komatsu certified technician.

1. Use a wire stripper to remove 3 inches of outer jacket from the each of the wiring harnesses (FIG. 63).

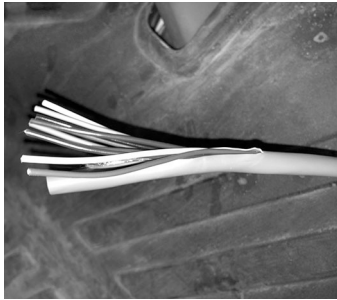

FIG. 63

2. Cut back and tape any wires that will not be used in the lubrication system (FIG. 64).

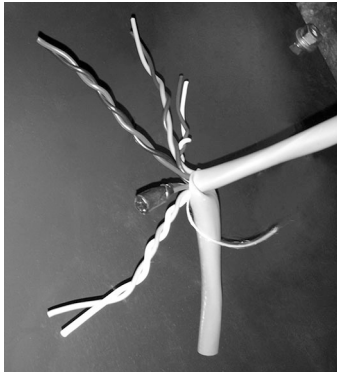

FIG. 64

Each wire connection should be assembled using the following Wire Splicing procedure:

Refer to the following Wiring Table for wire connection between the GLC2200 controller, G3 pump, proximity switch, and main power.

GLC2200 Wiring Table

GLC2200 Harness			Prox	Pump
Color	Description	+/-	Color	Color
Blue	Pump	-	Blue	Black
Purple	Unused (cut)	-		
Brown	Low Level Input	-		Orange
White	Prox Switch Signal	-	Black	
Black	Voltage Input 24VDC	-		
Orange	Pump	+	Brown	Red
Green	Unused (cut)	+		
Yellow	Low Level Input	+		White or Yellow
Gray	Unused (cut)	+		
Red	Voltage Input 24VDC	+		

Wire Splicing

1. Remove 1 inch of insulation using a wire stripper (FIG. 65).



FIG. 65

2. Slide 1.5 inches of shrink tubing over end of one piece of wire (FIG. 66).

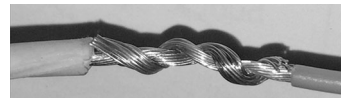

FIG. 66

3. Connect two (or more) wire ends together by twisting the stripped wire ends of wires together.



FIG. 67

4. Solder connection with a soldering iron.
5. Slide the shrink tubing over the soldered wires. Use a heat gun to contract the shrink tubing (FIG. 68).

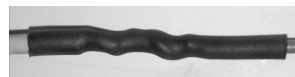

FIG. 68

6. Repeat Steps 181 - 5 for all wires.
7. Wrap wiring assembly with electrical tape or cable loom to protect connection.
8. Locate the proximity switch / G3 power cable wiring under the driver's floor mat.

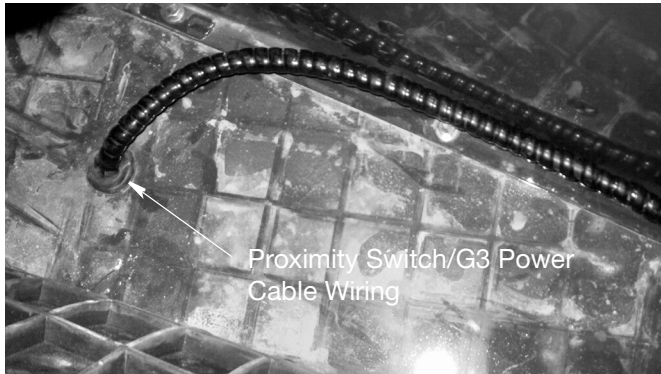

FIG. 69

9. Refer to FIG. 70 for a wiring example.

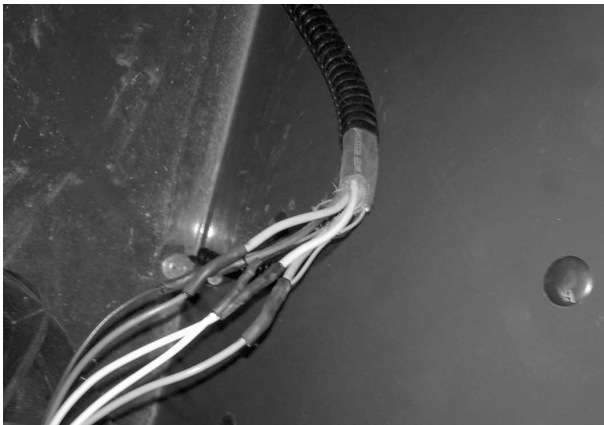

FIG. 70

10. Wrap wiring with hose loom or electric tape as shown in FIG. 71.



FIG. 71

11. Route wiring under mat and behind operator's seat (FIG. 72).



FIG. 72

12. Route GLC2200 connector through access grommet behind operator's seat (FIG. 73).



FIG. 73

13. Remove bolt covers (*bc*), bolts and washers from cab cover panel located on the right side of the cab, next to the driver's seat as shown in FIG. 75. Remove the convenience center from its installation location to access the electric connections.

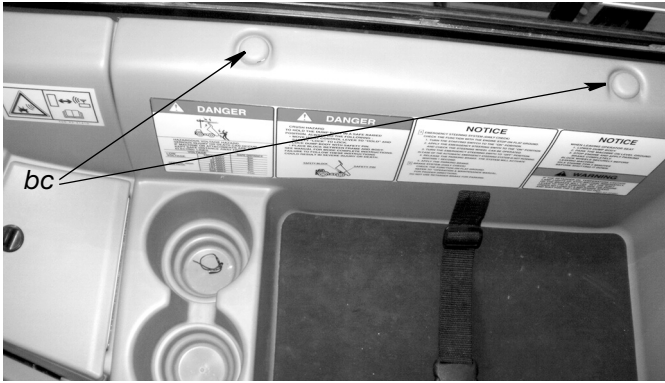

FIG. 74

14. Remove bolt covers (*bc*), bolts and washers (*w*) from the panel behind the driver's seat as shown in FIG. 75. Keep washers (*w*). They will be used for GLC2200 installation.

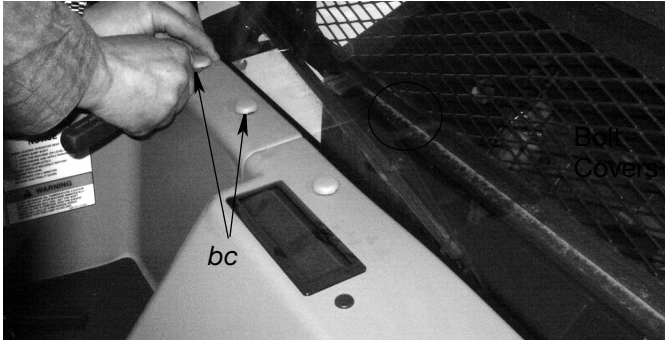

FIG. 75

15. Pull GLC2200 power cable routed through the access grommet in Step 12, through open cover as shown in FIG. 76.

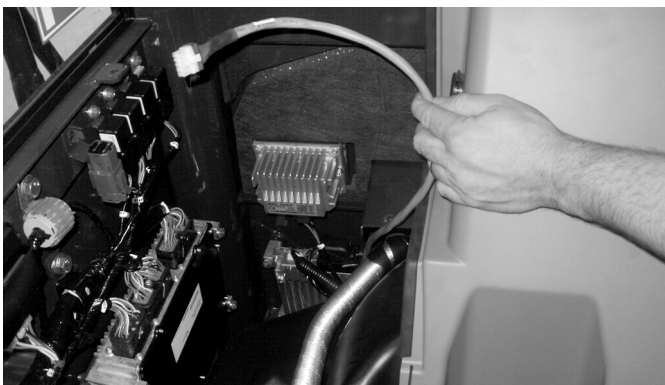

FIG. 76

16. Splice the GLC2200 cable open to access red (+) and black (-) power wires. Be careful not to damage the other wires in the cable (see FIG. 77).



FIG. 77

17. Cut and remove 2 to 3 feet (0.61 m to 0.91 m) of red (+) and black (-) wire from the cable assembly (see FIG. 78).



FIG. 78

18. Remove fuse box cover (FIG. 79).

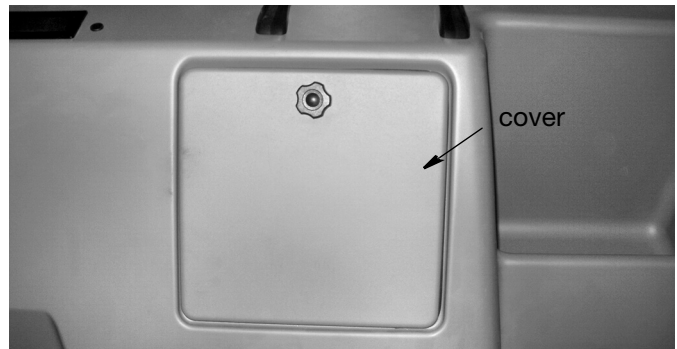

FIG. 79

19. Remove the fuse panel cover.

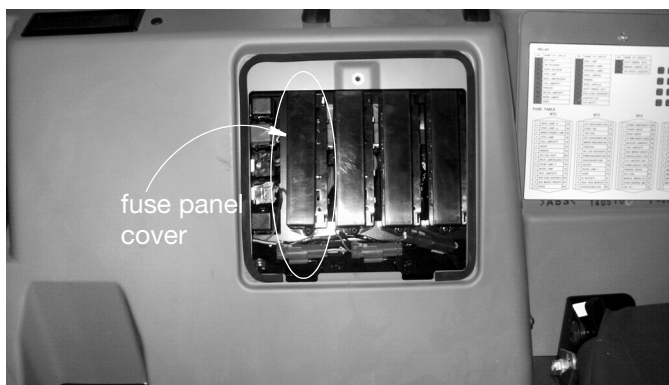

FIG. 80:

- Pull the cable through the back of the relay panel, into the fuse panel and out through the panel cover (FIG. 81).
- Follow the same wiring splicing procedure as before (see Steps 1-5, page 38). Attach a ring terminal to the controller ground wire (FIG. 81).

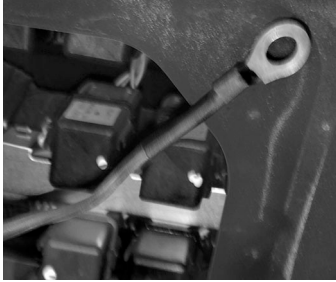

FIG. 81

- Attach an ATM fuse splice connector to the power wire of the controller (FIG. 82) using the wiring procedure described in Steps 18-5 on pages 40 and 38. Install a 5 Amp fuse.

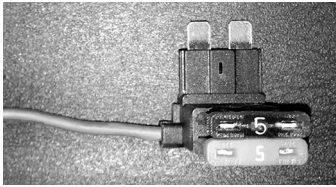

FIG. 82

- Remove a bolt from the relay rail closest to the fuse panel and connect the grounding ring installed in Step 21 to the bolt. Re-tighten bolt (FIG. 83).



FIG. 83

- In the fuse box locate the fuse labeled "SPARE" (FIG. 84).

NOTE: The SPARE should be located on the bottom left side of the fuse panel table.

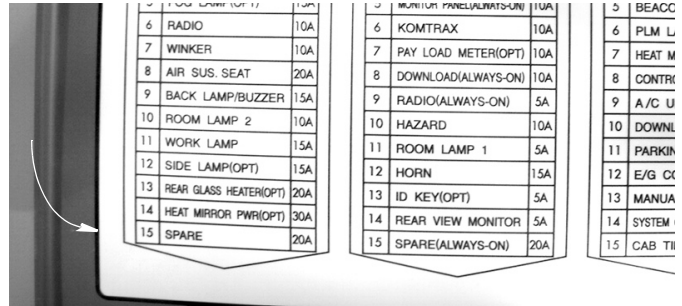

FIG. 84

- Connect the Add-A-Fuse with both 5 Amp fuses installed into the fuse panel slot labeled "SPARE".

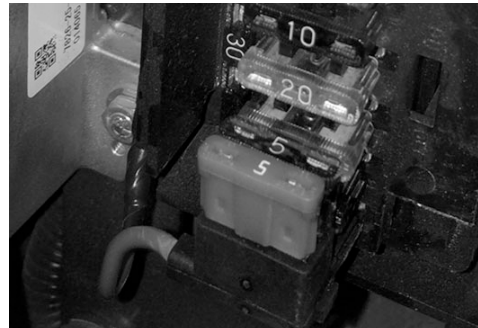

FIG. 85

- Reinstall the fuse cover over the top of the fuse panel and the Add-A-Fuse.
- Reinstall the relay and fuse panel covers.

GLC2200 Controller

The GLC2200 Controller Installation includes the following components:

- GLC2200 Controller
- Mounting bracket and hardware
- GLC2200 cable
- Zip ties

Remove all components from the packaging and place all parts on a clean, flat surface.

GLC 2200 Mounting Bracket Installation

The mounting bracket kit includes the following components:

Ref	Description	Qty
a	Mounting Bracket	1
b	Mounting Bolts	6
c	Washers	14
d	Nuts	6
e	Mounting Base Plate	1
f	Mounting Plate	1
g	Mounting Bracket to Cab	2
h	Washer, nylon	2
j	Screw, pan head	2
k	Nut	2

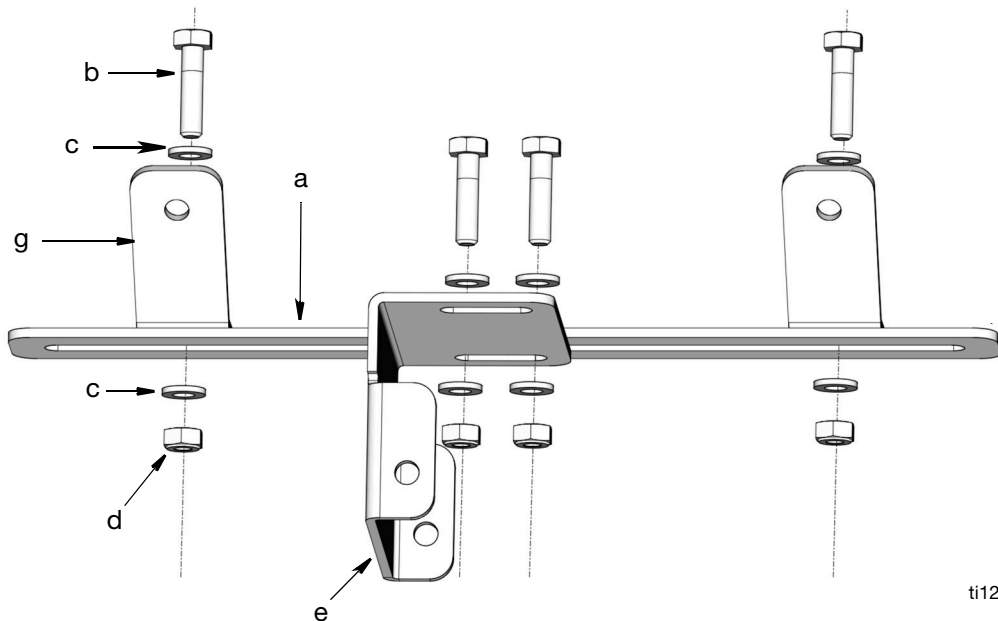

ti126313

FIG. 86

1. Assemble the GLC2200 mounting bracket:
 - a. Install the GLC2200 mounting base plate (e) to the mounting bracket (a) using bolts (b), washers (c) and nuts (d) as shown in FIG. 86. Wrench tighten nuts securely.
 - b. Install bracket fasteners (g) to mounting bracket (a) using bolts (b), washers (c) and nuts (d) as shown in FIG. 86. Fasten loosely to allow for final adjustment when installed to the Komatsu equipment.

- c. Install the GLC200 mounting plate (f) to the mounting base plate (e) using bolts (b), washers (c) and nuts (d) as shown in FIG. 87. Be sure washer (h) is installed between the mounting plate (f) and mounting base plate (e) on the top and bottom. Wrench tighten nuts securely.

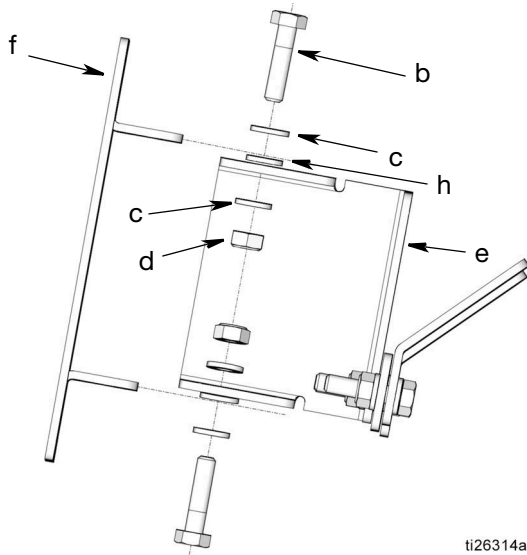

FIG. 87

- d. Install the GLC200 controller on the mounting plate (f) using screws (j), and nuts (k) as shown in FIG. 88. Tighten mounting bolts just enough to secure the controller in the bracket. Adjust the GLC2200 controller for the best viewing angle then wrench tighten bolts securely.

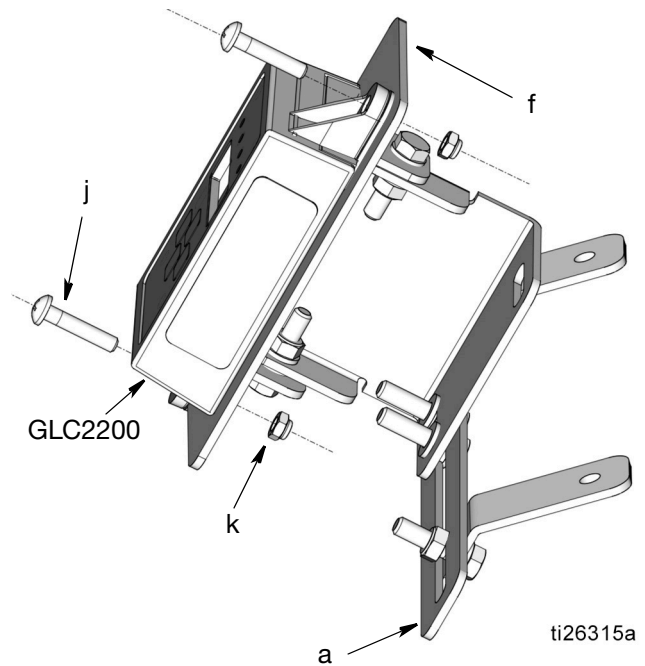

FIG. 88

- e. Adjust bracket fasteners (g) (installed in Step) for installation in the cab; matching the holes in the brackets to the location of the bolt holes available after removing the bolt cover and bolts in Step 14 (FIG. 75, page 40).
- f. Wrench tighten nuts (d) to secure bracket fasteners (g) to bracket (a).
2. Install the assembled bracket and GLC2200 to the mounting holes exposed in Step 14 (FIG. 75, page 40). Use bolts (b) and washer (c) and washer (w) to secure bracket fasteners (g) to the holes.
 3. Connect the GLC2200 wiring harness to the GLC2200 controller.

Hose Assemblies

The hose in the kit is provided in bulk and the fittings are field installable; a crimper is not required.

A list of the hose assemblies needed and the assembly requirements for both 1/8 in. and 1/4 in. hoses is provided in the Hose Assembly Tables. US Measurements are provided on page 47 and Metric Measurements are provided on page 48.

NOTE: In the Hose Assembly Table:

- Assembled hose lengths with fittings are shown as Overall Length.
- Use the Cut Length measurement when cutting the hose from the roll.

Hose Assembly Instructions

1. Wrap or slide spiral wrap (sw) over the end of the cut-to-length hose (h) until the entire length of the hose is encased in the spiral wrap.
2. Trim the spiral wrap (sw), leaving approximately 1 inch (25.4 mm) of the hose end unwrapped (FIG. 89).

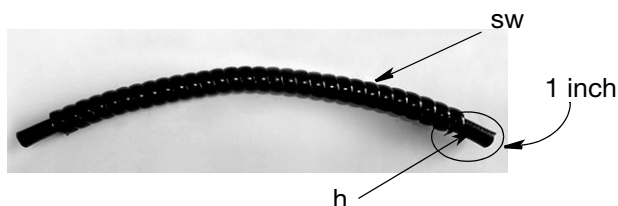

FIG. 89

Spring Guard†

Some hoses require additional protection and should also be wrapped with a hose spring guard.

NOTE: On the Hose Assembly Tables, hoses requiring a spring guard are identified with a †.

- a. Slide the hose spring guard (sg) over the end of the spiral wrapped hose. Feed the hose assembly into the hose spring guard until the entire length of the hose is encased in the hose spring guard.
- b. Trim the hose spring guard (sg) so it is long enough to cover hose assembly.

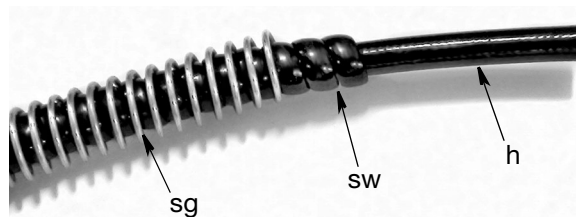

FIG. 90

3. Remove two hose fittings from their package and disassemble the two pieces (FIG. 91).

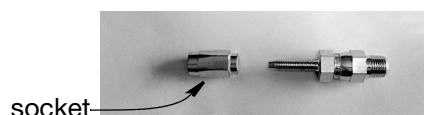

FIG. 91

4. Connect the socket to the end of the hose. Rotate the fitting counter-clockwise to thread the hose fitting onto the hose (FIG. 92).

NOTE: A wrench and pliers may be needed to assist with this assembly. If socket is difficult to install, apply lubricant that is compatible with the hose material.



FIG. 92

5. Leave approximately 1/16 in. of the hose end before completely seating the hose into the fitting. This will allow enough space for the second half of the fitting to be connected (FIG. 93).
6. Generously lubricate nipple, socket, threads and hose inside diameter.



FIG. 93

7. Thread the stud of the nipple clockwise into the socket installed in the hose until the nipple nearly bottoms out against the socket shoulder (FIG. 94).

NOTE: Two hand wrenches may be needed to assist with this assembly.

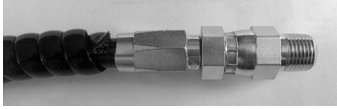

FIG. 94

NOTICE

Do not over tighten the fittings during final assembly. After the two fittings are securely connected, stop tightening the fittings. Over-tightening can damage the fittings and a new hose assembly will need to be made.

If the ferrule sleeve is difficult to install, check the hose for proper lubrication. Reapply lubricant as needed. Installation without proper lubrication can cause damage to the core tube.

8. Repeat Steps 1-7 for all hose assemblies.

Hose Assembly Table - US Measurements (NOTE: Metric measurements are provided on page 48)

Group	Lube Point Description	Size	Cut Length* inches	
			HM300-5	HM400-5
Pump to Master		1/4 in.	72.5	74.5
Master to Rear Secondary		1/4 in.	263.5	276.5
Master to Middle Secondary		1/4 in.	143.5	141.5
Front Secondary	Transmission Rear Trunnion	1/8 in.	35.5	29.0
Front Secondary	Suspension Cylinder Pin Upper	1/8 in.	35.5	49.0
Front Secondary	Suspension Cylinder Pin Lower	1/8 in.	35.5	49.5
Front Secondary	Steering Cylinder Bottom Pin	1/8 in.	35.5	51.0
Front Secondary	Transmission Front Trunnion	1/8 in.	35.5	40.5
Front Secondary	Suspension Cylinder Pin Upper	1/8 in.	35.5	48.5
Front Secondary	Suspension Cylinder Pin Lower	1/8 in.	35.5	48.5
Front Secondary	Steering Cylinder Bottom Pin	1/8 in.	35.5	40.5
Middle Secondary	Upper Pivot	1/8 in.	265.5	220.5
Middle Secondary	Steering Cylinder Left Pin	1/8 in.	266.5	191.5
Middle Secondary	Dump Body Cylinder	1/8 in.	94.5	99.5
Middle Secondary	Axle Pivot Front Fittings	1/8 in.	266.5	218.5
Middle Secondary	Lower Pivot	1/8 in.	268.5	216.5
Middle Secondary	Steering Cylinder Right Pin	1/8 in.	244.5	228.5
Middle Secondary	Dump Body Cylinder	1/8 in.	140.5	137.5
Middle Secondary	Axle Pivot Rear	1/8 in.	72.5	29.5
Rear Secondary†	Dump Cylinder Rod	1/8 in.	139.5	163.5
Rear Secondary	Tail Gate Pivot	1/8 in.	134.5	163.5
Rear Secondary	Dump Body Pivot Pin	1/8 in.	41.5	47.5
Rear Secondary	Equalizer Cylinder Upper Right	1/8 in.	84.5	107.5
Rear Secondary	Equalizer Cylinder Lower Right	1/8 in.	104.5	130.5
Rear Secondary†	Dump Cylinder Rod	1/8 in.	139.5	163.5
Rear Secondary	Tail Gate Pivot	1/8 in.	134.5	163.5
Rear Secondary	Dump Body Pivot Pin	1/8 in.	41.5	47.5
Rear Secondary	Equalizer Cylinder Upper Left	1/8 in.	84.5	107.5
Rear Secondary	Equalizer Cylinder Lower Left	1/8 in.	104.5	137.5

† Additional hose assembly instructions for this hose are provided in the **Hose Assembly, Spring Guard** instructions section on page 45.

*Allow sufficient hose for complete dump bed articulation that does not place stress on the hose fittings and connections during daily operation.

Hose Assembly Table - Metric Measurements

Group	Lube Point Description	Size	Cut Length* - mms	
			HM300-5	HM400-5
Pump to Master		1/4 in.	1841.0	1892.0
Master to Rear Secondary		1/4 in.	6693.0	7023.0
Master to Middle Secondary		1/4 in.	3696.0	3594.0
Front Secondary	Transmission Rear Trunnion	1/8 in.	901.7	736.6
Front Secondary	Suspension Cylinder Pin Upper	1/8 in.	901.7	1245.0
Front Secondary	Suspension Cylinder Pin Lower	1/8 in.	901.7	1257.0
Front Secondary	Steering Cylinder Bottom Pin	1/8 in.	901.7	1295.0
Front Secondary	Transmission Front Trunnion	1/8 in.	901.7	1029.0
Front Secondary	Suspension Cylinder Pin Upper	1/8 in.	901.7	1232.0
Front Secondary	Suspension Cylinder Pin Lower	1/8 in.	901.7	1232.0
Front Secondary	Steering Cylinder Bottom Pin	1/8 in.	901.7	1029.0
Middle Secondary	Upper Pivot	1/8 in.	6744.0	5601.0
Middle Secondary	Steering Cylinder Left Pin	1/8 in.	6769.0	4864.0
Middle Secondary	Dump Body Cylinder	1/8 in.	2400.0	2527.0
Middle Secondary	Axle Pivot Front Fittings	1/8 in.	6769.0	5550.0
Middle Secondary	Lower Pivot	1/8 in.	6820.0	5499.0
Middle Secondary	Steering Cylinder Right Pin	1/8 in.	6210.0	5804.0
Middle Secondary	Dump Body Cylinder	1/8 in.	3569.0	3492.0
Middle Secondary	Axle Pivot Rear	1/8 in.	1841.0	749.3
Rear Secondary†	Dump Cylinder Rod	1/8 in.	3543.0	4153.0
Rear Secondary	Tail Gate Pivot	1/8 in.	3416.0	4153.0
Rear Secondary	Dump Body Pivot Pin	1/8 in.	1054.0	1206.0
Rear Secondary	Equalizer Cylinder Upper Right	1/8 in.	2146.0	2730.0
Rear Secondary	Equalizer Cylinder Lower Right	1/8 in.	2654.0	3315.0
Rear Secondary†	Dump Cylinder Rod	1/8 in.	3543.0	4153.0
Rear Secondary	Tail Gate Pivot	1/8 in.	3416.0	4153.0
Rear Secondary	Dump Body Pivot Pin	1/8 in.	1054.0	1206.0
Rear Secondary	Equalizer Cylinder Upper Left	1/8 in.	2146.0	2730.0
Rear Secondary	Equalizer Cylinder Lower Left	1/8 in.	2654.0	3492.0

† Additional hose assembly instructions for this hose are provided in the **Hose Assembly, Spring Guard** instructions section on page 45.

*Allow sufficient hose for complete dump bed articulation that does not place stress on the hose fittings and connections during daily operation.

Hose Routing

Routing hose lines takes time. It is easier when there are two people working on the installation together.

- Route hoses by following the path of the already installed electrical or hydraulic lines.

- Route the lines to the grease point **but do not connect the lines to the fitting**. Take care to ensure dirt and/or debris do not get on the grease fitting or introduced into the system.
- Secure lines using the supplied zip ties.

Pump to Master Divider Valve

HM300-5 Models

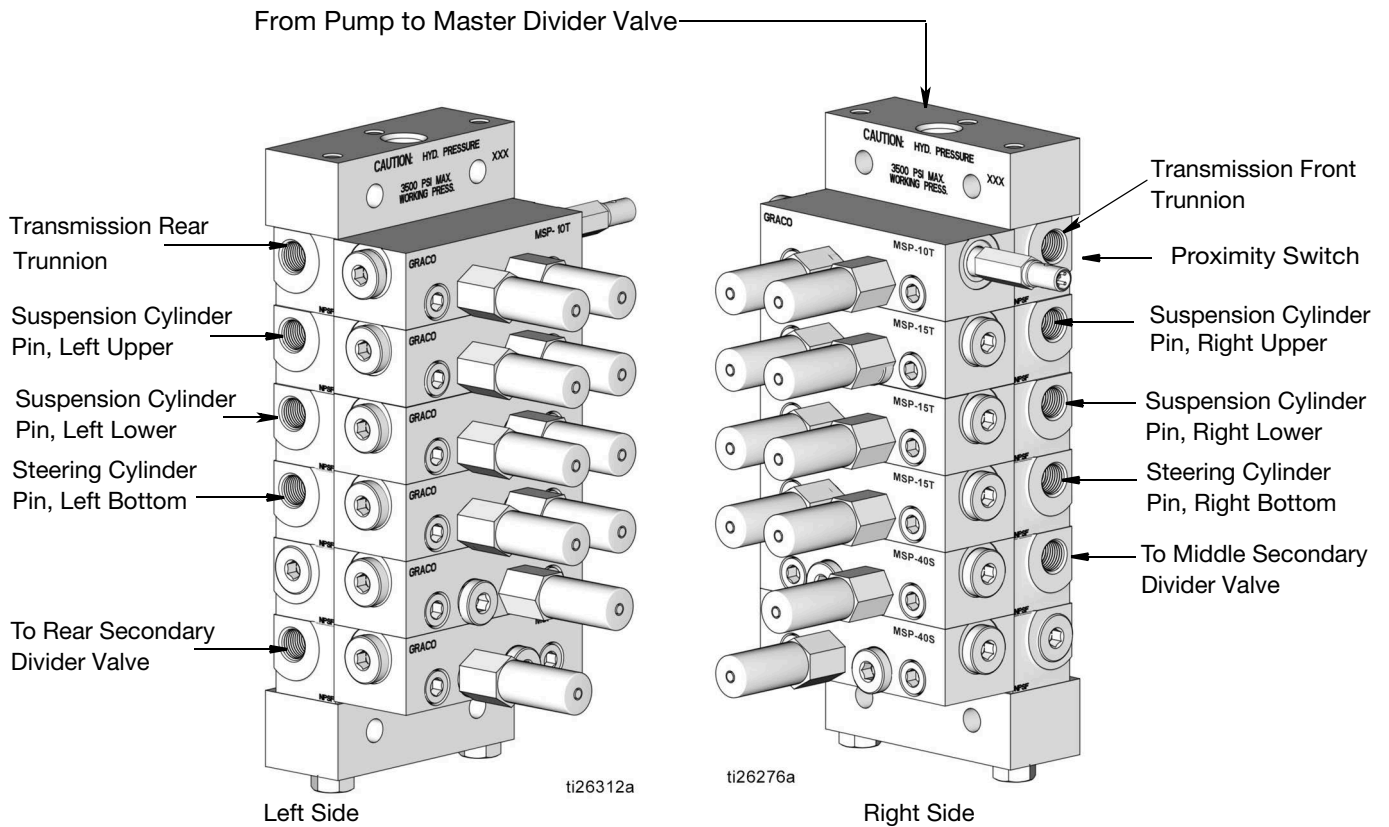

FIG. 95

HM400-5 Models

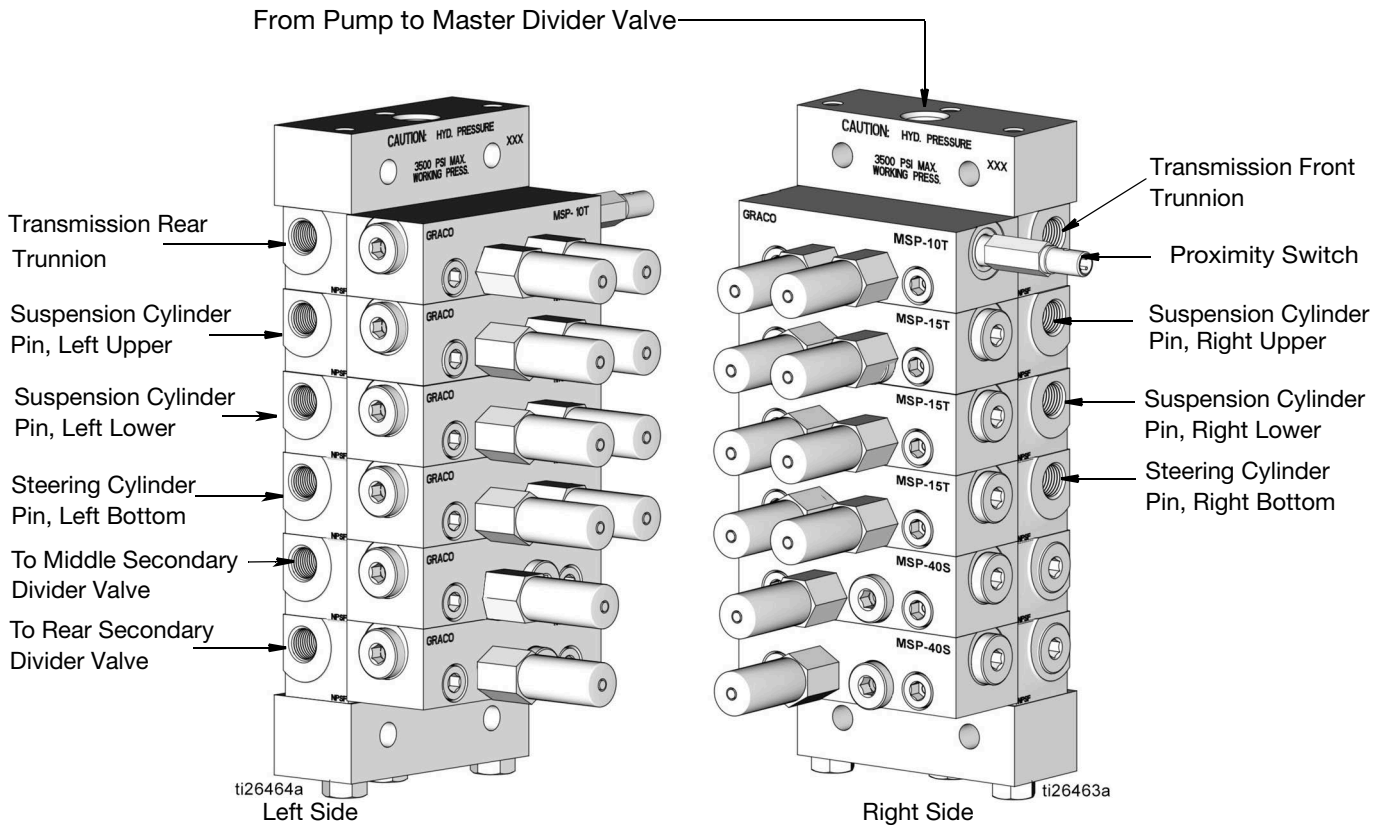

FIG. 96

Master Divider Valve Hose Connections (FIG. 97).

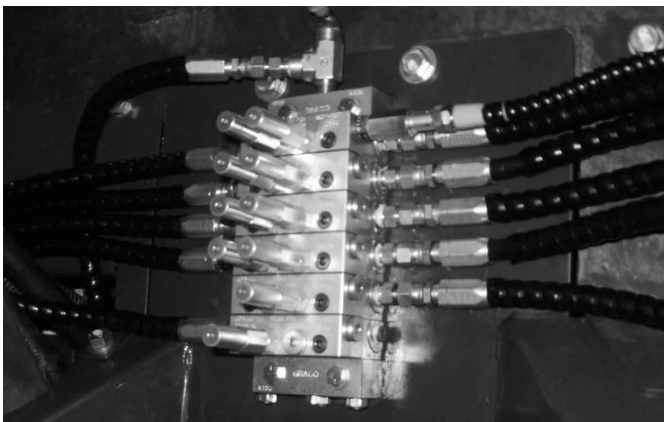

FIG. 97: HM300-5

Refer to FIG. 95 and FIG. 97 for all hose routing connections to the Master/Front Secondary MSP Divider Valve.

- Secure hose lines together using the supplied zip ties.
- Refer to the following installation photographs for hose routings between the Master/ Front Secondary Divider Valve and the related lubrication points.

Master Divider to Pump

Loosely connect the hose to the pump (FIG. 98). Run the main feed line hose between the pump and the Master Divider Block (FIG. 99).

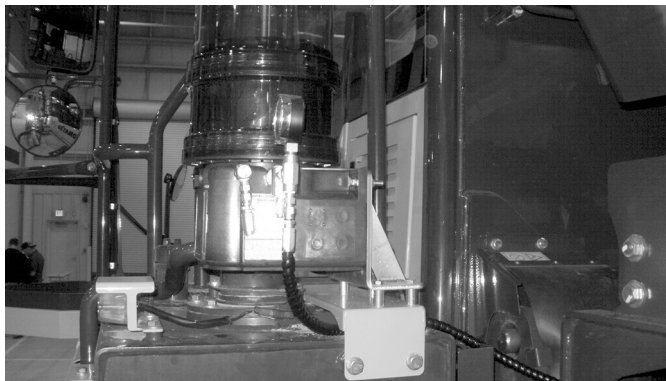

FIG. 98

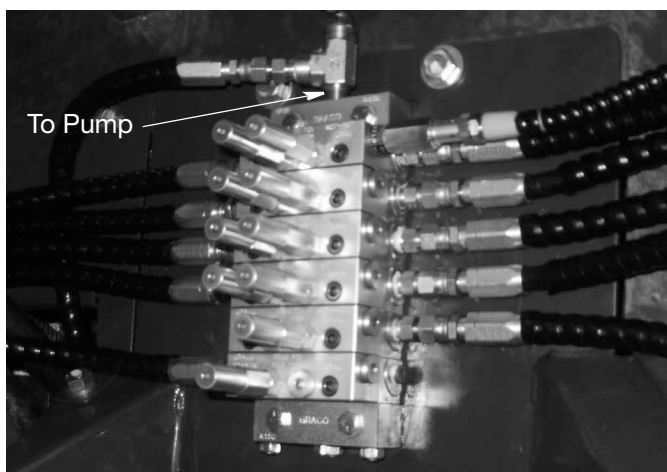

FIG. 99

Master Divider Valve and Right Side Hose Connections

Install the following hoses to the right side of the Master Divider Valve:

- Transmission Front Trunnion,
- Suspension Cylinder Pin Right Upper,
- Suspension Cylinder Pin Right Lower, and
- Steering Cylinder Pin Right Bottom
- To Middle Secondary Divider Valve

Route the hoses behind the large bundle of tubes and hoses behind the cab on the right side and into the access panel (FIG. 100) to the related lube points inside the panel (FIG. 101).

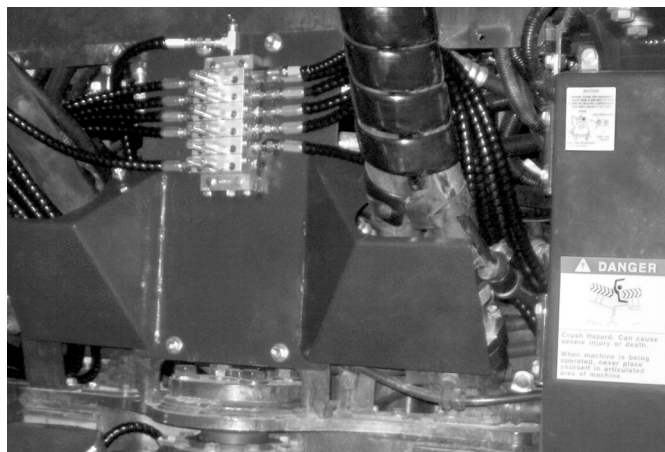

FIG. 100

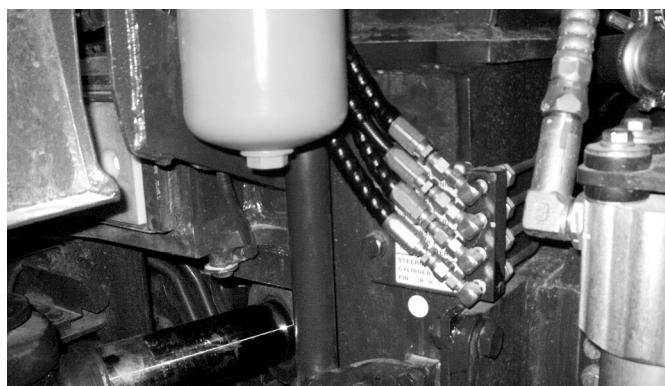

FIG. 101

Hose Routing - Master to Middle Secondary Divider Valve.

It is not necessary to unwrap the hose wrap around the equipment's tubes and hoses on the right since only one hose (between the Master Divider Valve and the Middle Secondary Divider Valve) follows this hose path (FIG. 102).

Carefully feed the hose under the hose wrap. Then run the hose along the right side truck support rail following the same path as the existing tubing to the Middle Secondary Divider Valve.

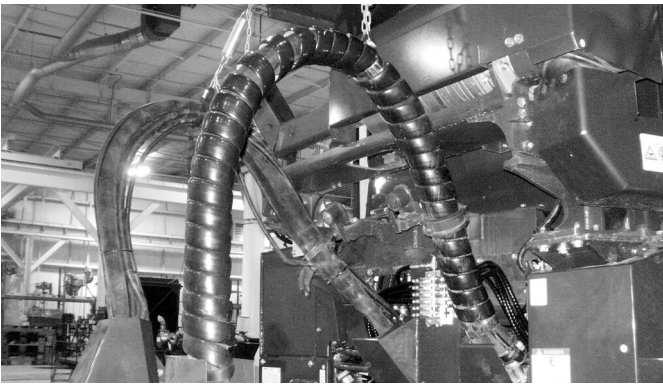

FIG. 102: HM300-5



FIG. 103: HM300-5

Hose Routing - Master to Left Side Lube Points and Rear Secondary Divider Valve.

1. Unwrap the hose wrap around the equipment's tubes and hoses on the left side of truck (FIG. 104).

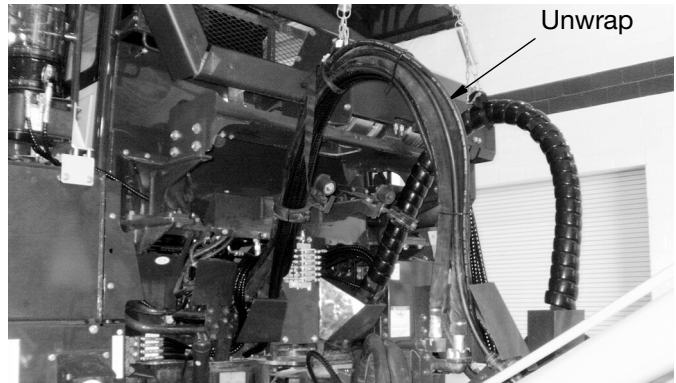

FIG. 104: HM300-5

2. Install the following hoses to the left side of the Master Divider Valve:

- Transmission Rear Trunnion,
- Suspension Cylinder Pin Left Upper,
- Suspension Cylinder Pin Left Lower, and
- Steering Cylinder Pin Left Bottom
- To Rear Secondary Divider Valve

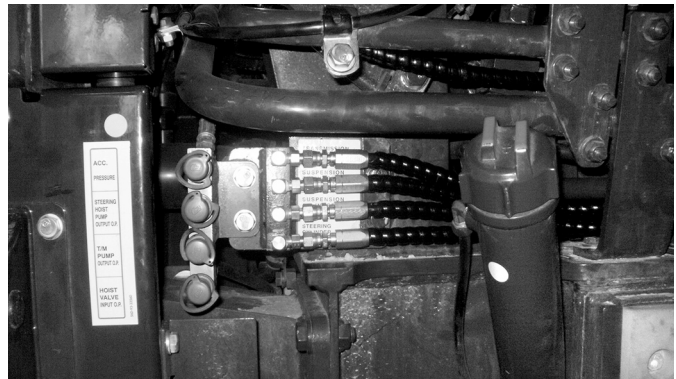

FIG. 105: HM300-5

- Use zip ties to secure hose bundles. Refer to FIG. 106 - FIG. 111 for the hose routing paths to the Middle Secondary and Rear Second Divider Valve and lubrication points.

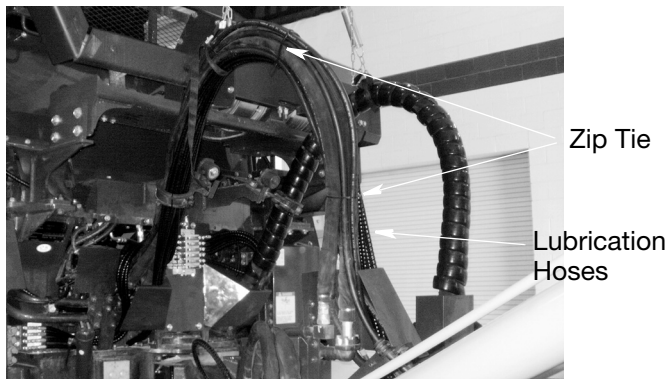

FIG. 106: Hose routing left side. Hoses added to equipment's hoses and tubes on HM300-5.



FIG. 107: Hoses left side to left side dump body frame rail on HM300-5.



FIG. 108: Hoses running along left side dump body frame rail to back of truck dump bed on HM300-5.

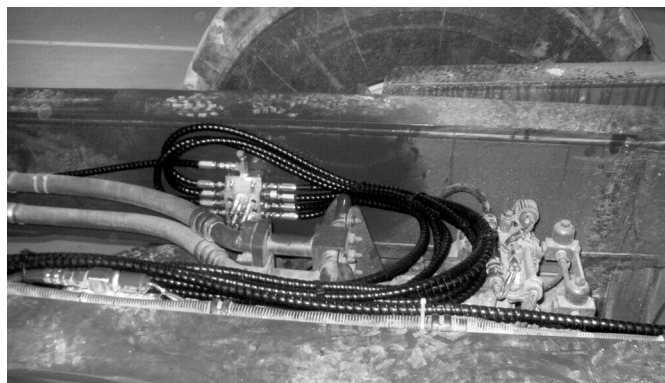

FIG. 109: Lubrication hoses routed across dump bed to Middle Secondary Divider Valve installed inside of the right side dump body frame rail on HM300-5.



FIG. 110: Master to Rear Secondary Valve supply hose. Routed along left side dump body frame rail to divider valve on HM300-5.



FIG. 111: Lubrication hoses routed to Rear Secondary Divider Valve on HM300-5.

Master Valve to Secondary Valves

Middle Secondary MSP Divider Valve

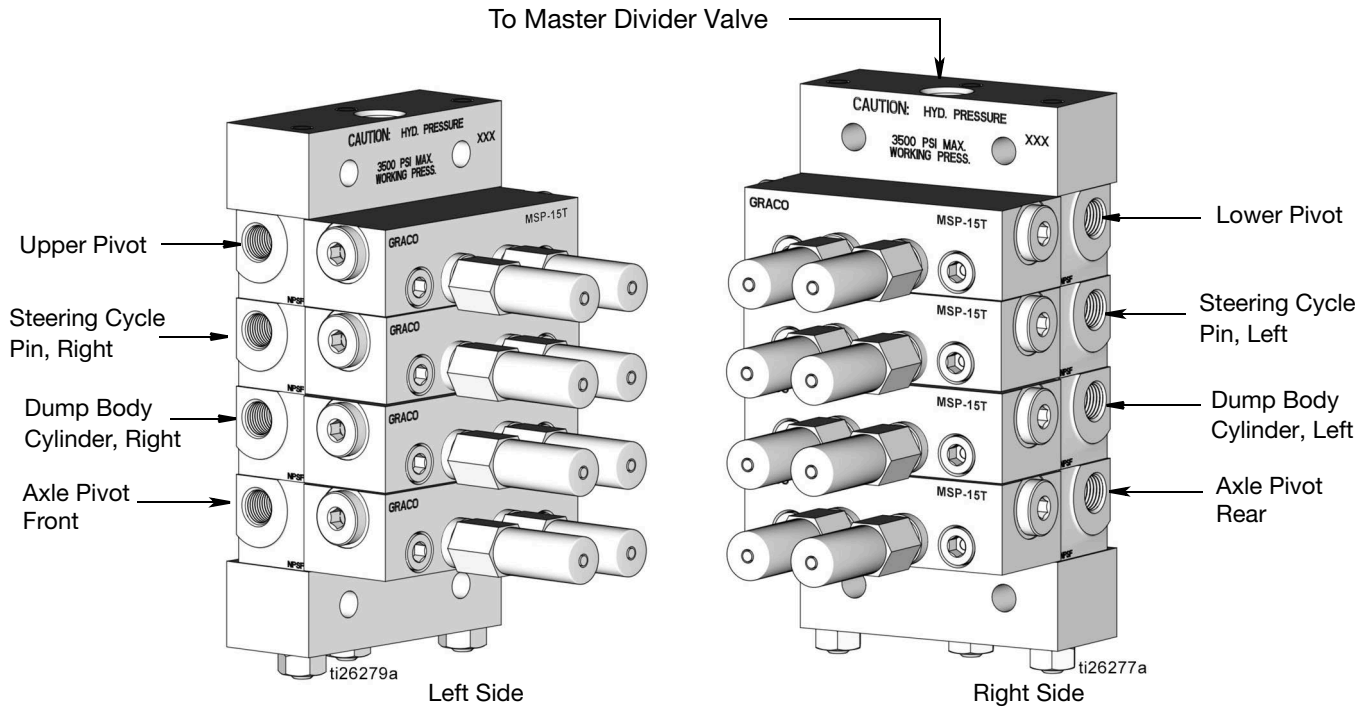

FIG. 112

Rear Secondary MSP Divider Valve

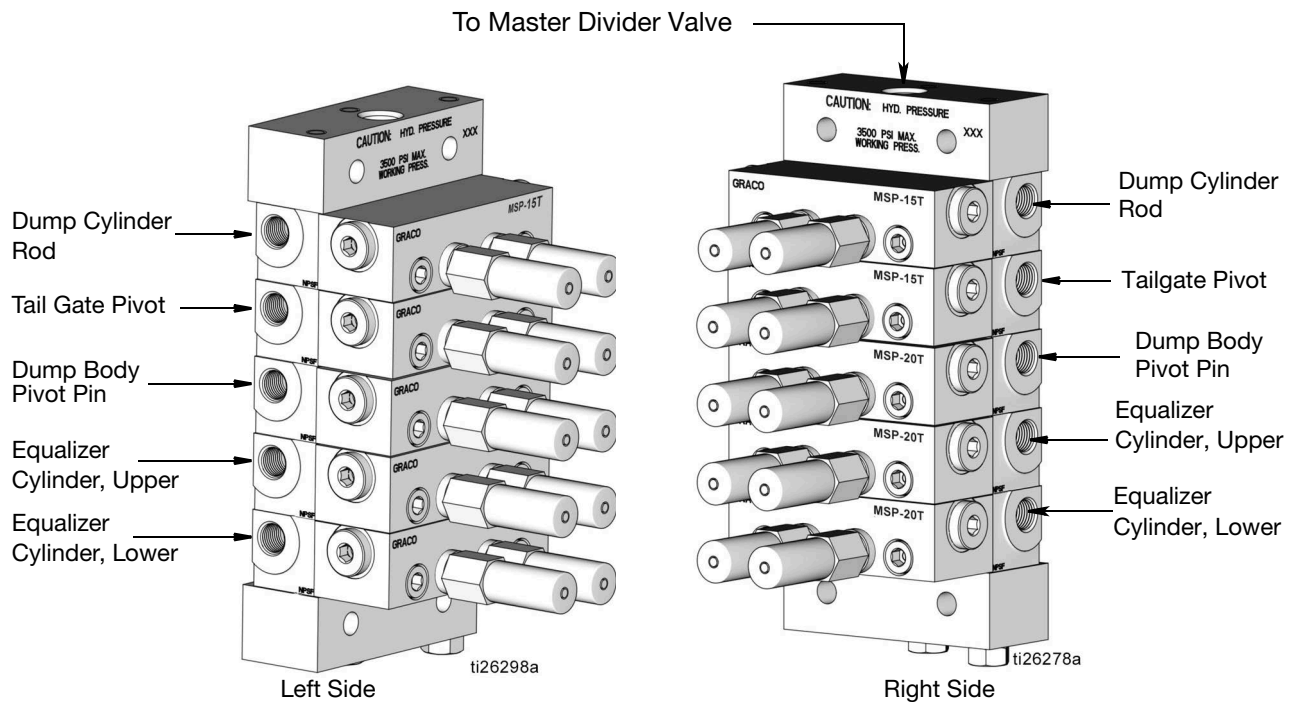

FIG. 113

- Connect the hoses to the Middle Secondary and Rear MSP Divider Valves and route to lubrication points.
- Secure lines using the supplied zip ties.

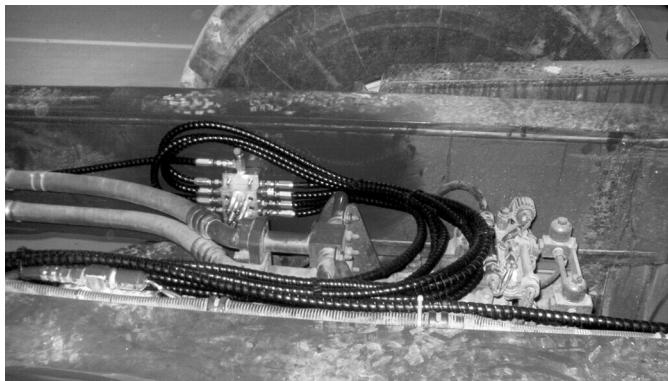

FIG. 114: Middle Secondary MSP Divider Valve



FIG. 115: Rear Secondary MSP Divider Valve

Installation Lube Point Reference Photos



FIG. 116: Hoist cylinder; right side



FIG. 117: Hoist cylinder; left side



FIG. 118

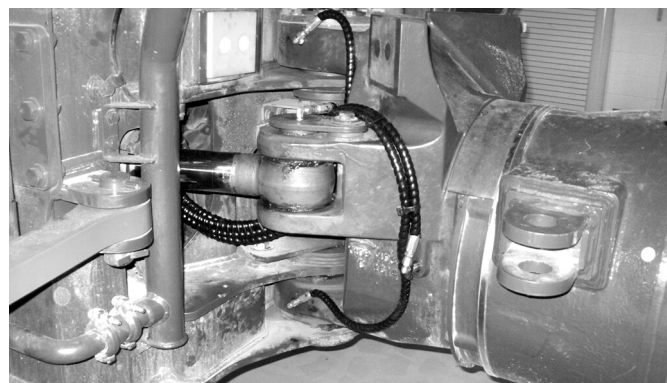

FIG. 119: Steering cylinder; left side

Guarding and P-Clamp

1. Attach the hose guard and P-clamps to both sides of the dump body using the previously installed weld studs.



FIG. 120

2. Reverse the orientation of the dump body cylinder rod end pins on each side of the equipment. Consult the Komatsu operation and maintenance manual for this procedure.



FIG. 121

3. Run lubrication lines to the lubrication points from Rear Secondary MSP Divider Valve (See reference photos FIG. 122 - FIG. 124).

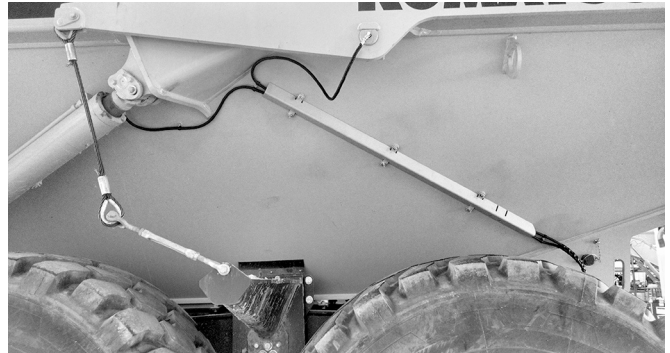

FIG. 122



FIG. 123



FIG. 124

GLC2200 Controller Programming

Component Identification

Keypad, Display, and Icons

NOTICE

To prevent damage to soft key buttons, do not press the buttons with sharp objects such as pens, plastic cards, or fingernails.

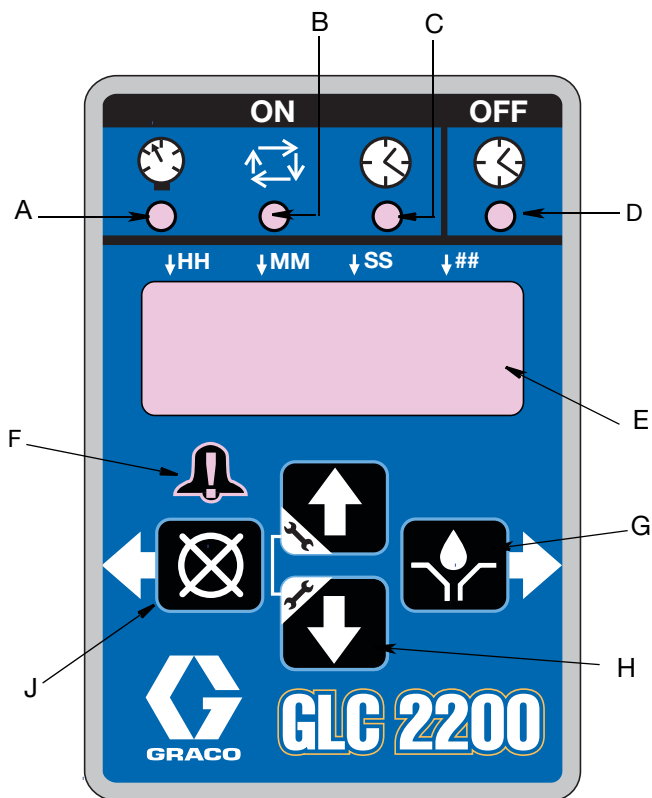

FIG. 125

Pump ON LEDs (A, B, C)

- A Pressure Control LED: In RUN MODE illuminates indicating function mode that is currently running.
- B Cycle Control LED: In RUN MODE illuminates indicating function mode that is currently running.
- C Time Control LED: In RUN MODE illuminates indicating function mode that is currently running.

Pump OFF LED (D)

- In RUN MODE this LED illuminates when in the OFF or RESET portion of the RUN CYCLE.

Display (E)

- A blinking field on the display indicates the controller is in SETUP MODE.
- In RUN MODE field of numbers on the display will not blink.

Alarm LED (F)

Illuminates when any alarm is detected. When an alarm is active an error code displays and an audible alarm also sounds.

RIGHT Direction Arrow / MANUAL RUN / ENTER (G)

- In SETUP MODE, saves entry, moves cursor in display one field to the right or to the next setup step.
- In RUN MODE activates the pump for one complete ON cycle if actuated during the OFF portion of the RUN cycle.

UP and DOWN Direction Arrows (H)

- Press and hold both the UP and DOWN Arrow keys together for 3 seconds to enter SETUP MODE.
- In SETUP MODE increase or decrease number values associated with the various RUN MODES.

LEFT Direction Arrow / RESET (J)

- In SETUP MODE moves cursor in display one field to the left.
- In RUN MODE, Pressing RESET starts a PUMP OFF cycle.
- In ALARM MODE, Press once to clear buzzer; Press and hold for 3 seconds to clear warning and switch controller to OFF MODE.

NOTE: See the GLC2200 Controller Instruction manual for detailed descriptions of the display features.

Programming the GLC200 Controller

Before programming the GLC2200 controller:

- Restore power to the equipment by engaging the main power switch to the equipment.
- Key on the machine to the “Acc” position.

1. Press both the UP and DOWN ARROW buttons together for three seconds.



2. Use the UP ARROW until **on:CY** displays.

on:CY



3. Press the ENTER button. This will allow the controller to count the number of times the master valve cycles to lubricate the machine.



The blinking field indicates the device is ready to program the number of cycles.

NOTE: The Cycle entry is a 2-digit number and requires a leading zero (0) must be entered in the first field. For this installation the master valve entry requires:

- 02 cycle times for HM300-5
- 02 cycle times for HM400-5

4. Program the first field by pressing the UP or DOWN ARROW until “0” appears in the first field.



5. Press the ENTER button.

The cursor automatically moves to the next field and flashes.



6. Program the next field by pressing the UP or DOWN ARROW until:

- “2” appears in the next field



7. Press the ENTER button.

The cursor automatically moves to set up the ON TIME Mode.



The LED below the clock in the ON field lights, indicating the ON TIME is being programmed. ON TIME is the amount of time the pump runs to complete all cycles set up in Steps 1-7.



NOTE: The ON TIME entry is a 4-digit number setting MM (minutes) and SS (seconds). For this installation the time is 5 minutes for the HM300-5 and the HM400-5 so a leading zero (0) must be entered in the first MM field.

8. Program the first minute field by pressing the UP or DOWN ARROW button until 0 appears in the first MM (minutes) field.



9. Press the ENTER button. The next MM number field to the right flashes indicating it is ready for programming.



10. Repeat steps 8 - 9 to set each of the remaining next MM and the SS (seconds) fields.



11. After pressing the ENTER button to set the last SS field, all the programmed Backup Time information is saved.



The controller automatically switches to the OFF Time SETUP MODE.

The LED below the OFF TIME Symbol Illuminates.



NOTE: The OFF TIME entry is a 4-digit number setting HH (hours) and MM (minutes). For this installation the time is 45 minutes.

- HH fields - enter two zeros (00) and
- MM fields - enter the numbers 4 and 5 for 45 minutes for the HM300-5 and the HM400-5 models.

To set the OFF TIME:

12. Program the first hour field by pressing the UP or DOWN ARROW button until 0 appears in the first HH (hour) field.



13. Press the ENTER button. The next HH number field to the right flashes indicating it is ready for programming.



14. Repeat steps 12 - 13 to set each of the remaining next HH and the MM (minutes) fields. Press the ENTER button.

The controller automatically switches to the LOW LEVEL SETUP MODE.

LOW LEVEL SETUP programs how the low level is detected by the controller. For this installation the LOW LEVEL SETUP is programmed to LL:02.

LL:02



1. Use the UP or DOWN ARROW until LL:02 displays.
2. Press the ENTER button.



Setup is complete. Listen for an audible “beep” signaling the controller is now programmed and has exited the SETUP MODE.

NOTE: See the GLC2200 Controller Instruction manual for detailed programming instructions.

Filling and Purging

- An automatic lubrication system must be free of air in order to generate enough pressure to cycle grease through the valves.
 - Take care to ensure dirt and/or debris do not get on the grease fitting or introduced into the system.
1. Connect a pneumatically powered grease gun to the grease zerk (a) on the G3 pump. Fill the G3 pump reservoir with grease to the “MAX” line mark (b) on the front of the reservoir (FIG. 126).

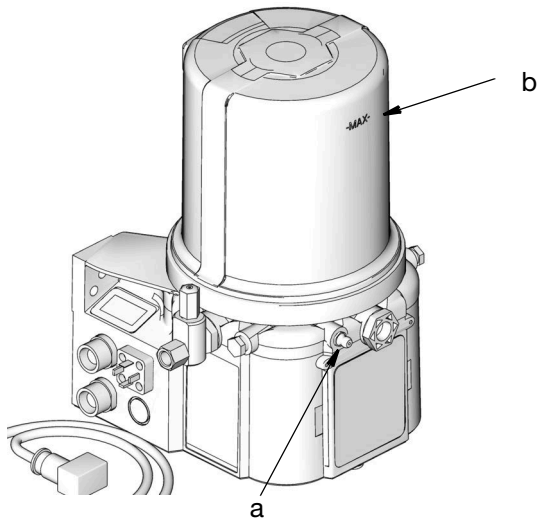

FIG. 126

2. Connect a pneumatically powered grease gun to the grease zerk (c) on the master valve to the pump (FIG. 127). Have a colleague stand next to the pump to identify when the main feed line from the pump is full and the air is purged from the line. Wrench tighten the fitting on the G3 pump, securely.

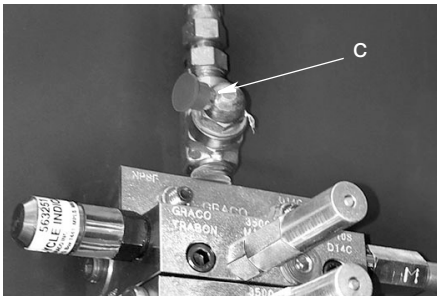

FIG. 127

3. Continue to fill the master valve and the grease lines to the secondary valves (FIG. 127). Have a colleague identify when the lines are filled and air is purged from the lines. Wrench tighten the inlet hose fittings on the secondary valves, securely.

NOTE: Use a waste container to capture excess grease from the feed lines.

4. Connect a pneumatically powered grease gun to the grease zerk (d) on the secondary valve to fill the secondary valves and their grease lines (FIG. 128). Have a colleague stand next to the grease lines from the secondary valves to the fittings to identify when the lines are filled and air is purged from the lines. Wrench tighten the secondary lines to the grease points, securely.

NOTE: Use a waste container to capture excess grease from the secondary lines.



FIG. 128

Testing



Before testing the system:

- be sure the G3 pump reservoir is filled,
 - all supply lines are connected securely,
 - verify all grease point fittings and hose connections are tight,
 - valves and grease lines are filled with grease and purged of air.
1. Turn on the battery disconnect to the machine and key on power in the cab to the “Acc” position.
 2. Verify the GLC2200 Controller has power.
 3. Press the Manual Run button on the GLC2200 Controller to run the lube system through several lube events. 
 4. While the pump is running, walk around the machine and inspect all pump, valve hose fittings and grease point connections to verify there are no leaks in the system.

- Articulate all working sections of the machine to ensure there is sufficient hose length supplied to all lubrication points.
 - Inspect all pump, valve hose fittings and grease point connections to verify there are no leaks, the hoses are secure and that all points are receiving grease.
7. If any of the fittings or connections are leaking, tighten fittings and/or make adjustments as needed.

Routine Service and Equipment Maintenance

Every time you complete the vehicle inspection checklist, walk around the machine to inspect all pump, valve hose fittings and grease point connections to verify there are no leaks in the system. This will ensure any damage to hoses or fittings is identified and repaired properly.

 WARNING	
 	<p>SKIN INJECTION HAZARD</p> <p>High-pressure fluid from dispensing device, hose leaks, or ruptured components will pierce skin. This may look like just a cut, but it is a serious injury that can result in amputation. Get immediate surgical treatment.</p> <ul style="list-style-type: none"> • Do not put your hand over the fluid outlet. • Do not stop or deflect leaks with your hand, body, glove, or rag. • Follow the Pressure Relief Procedure included in your pump instruction manual when you stop dispensing and before cleaning, checking, or servicing equipment. • Tighten all fluid connections before operating the equipment. • Check hoses and couplings daily. Replace worn or damaged parts immediately.

5. If any of the fittings or connections are leaking, tighten fittings and/or make adjustments as needed.
6. Put the machine into service and manually run the lubrication system.

NOTE: Photographs may include optional equipment.

Troubleshooting

NOTE: If the problem is not attributed to the Graco Lubrication System, consult the Komatsu Operations and Maintenance manual or your Komatsu dealer.

Problem	Cause	Solution
GLC2200 Controller does not turn on	No power to the machine	Check that the battery disconnect is ON and the keyed power is in the "Acc" position.
	GLC2200 Controller not wired correctly	Check to ensure the controller has been wired correctly by reviewing the GLC2200 Wiring Table on page 38.
GLC2200 Controller is in alarm mode; will not operate correctly	Fault is not cleared on controller	For 3 seconds, hold down the fault clear button (located on the left side of the controller). Controller fault should clear and begin OFF TIME countdown. See GLC2200 Controller instruction manual.
GLC2200 Controller goes into fault mode and displays ER:LL	G3 pump reservoir is empty	Refill G3 pump reservoir. After filling, press and hold the fault clear button on the GLC2200 controller for 3 seconds. See GLC2200 Controller instruction manual.
Audible alarm is sounding during machine operation	Machine requires service	To silence the alarm, press the fault clear button on the GLC2200 Controller for one second. Release button. The alarm will silence, but the system will remain in alarm mode until the machine is serviced.

Problem	Cause	Solution
<p>GLC2200 Controller is in fault mode and displays ER:Cy</p>	<p>The lubrication system failed to complete a lube event in the allowed 5 minute run time.</p>	<p>Verify the GLC2200 Controller is programmed to 2 cycles and 5 minutes run time for the HM300-5 and for the HM400-5. In colder temperatures, it may be necessary to exceed 5 minutes of run time to complete the lube cycle. Adjust to 6 or 7 minutes.</p>
	<p>MSP master valve reset indicator pin is protruding. Hose is damaged</p>	<p>If the first solution does not correct the problem, run a manual cycle and check the pump relief valve for discharged grease. The gauge should display 3000 psi (20.68 MPa, 206.8 bar) when the relief valve discharges. If grease has discharged from the relief valve, a bearing may have stopped taking grease, a grease line may be compromised, or the MSP valve may be clogged.</p>
	<p>MSP master valve reset indicator pin is protruding. Valve is not accepting grease and blocked.</p>	<p>Inspect MSP master valve to find reset indicator with a protruding pin. Follow the corresponding hose to the secondary valve. Replace hose.</p> <p>If the hose is not compromised, inspect the corresponding secondary valve for a pin protruding from the secondary valve. Use a grease gun to verify the valve is accepting grease.</p> <p>If the valve is blocked, replace valve.</p> <p>Repeat as needed for all MSP valves.</p>
<p>MSP Valves fail to accept grease</p>	<p>MSP valve not torqued to required specification or overtightened</p>	<p>Check MSP valve torque. Tighten if not torqued to required specification. If overtightened, adjust valve assembly and retest.</p>

Problem	Cause	Solution
Bearings not receiving enough grease	GLC220 Controller OFF TIME set too long.	<p>Reset the GLC2200 Controller OFF TIME to a shorter amount of time. This will engage a lube event more frequently and increase the amount of grease the bearings receive in a day.</p> <p>Alternative settings: 35 minutes = 30% increase 30 minutes = 50% increase 22 minutes = 100% increase</p> <p>See OFF TIME setup beginning with Step 12, page 59</p>
GLC2200 will not allow programmed time	Hours, minutes or seconds field not set correctly on GLC2200 Controller	Verify you are programming the hours, minutes, and seconds fields correctly. Refer to Programming the GLC2200 Controller instructions, page 57 or refer the GLC2200 Controller instruction manual.
G3 Pump does not build or hold pressure	Broken hose	The kit comes with extra hoses and fittings. If a replacement hose is needed, use these extra parts to make a replacement or contact your local Graco distributor to order a replacement part.

Parts

Part	Description
96G198	PUMP, G3, 8L
24N468	CONTROL, GLC 2200
24W981	CABLE, harness, GLC 2200 10 ft
125910	BRACKET, pump, windmill
563161	VALVE, relief 3000 assy
571058	KIT, accessory, output adapter
24G486	PLATE, base, 4 section MSP npsf
24G487	PLATE, base, 5 section MSP npsf
24G488	PLATE, base, 6 section MSP npsf
562721	VALVE, assy MSP 10T
562722	VALVE, assy MSP 15T
562723	VALVE, assy MSP 20T
562718	VALVE, assy MSP 40S
557349	PLUG, dryseal 1/8 nptf
556762	CONNECTOR, #4, JIC, 1/4 PM
555749	CONNECTOR, #4 JIC 1/8 PM
556763	FITTING, #4 JIC 1/8 PM
556773	FITTING, swivel, fem, SAE #4, JIC
128572	KIT, accessory, hose, 100 ft
128582	KIT, accessory, guard, 100 ft, 1/4 inch
127013	FITTING, swivel, JIC 37D size #4
128570	KIT, accessory, hose, 200 ft, 1/8 inch
557392	ADAPTER, 1/8 nptf hex
557393	COUPLING, 1/8 fp x 1/8 mp x 1-1/4 ex
126331	HARNESS, wiring, m12(f) to bare wire
24K415	KIT, accessory, prox sensor
563251	INDICATOR, cycle assy soft seal
563257	INDICATOR, reset assy 2000 psi (13.79 MPa, 137.9 bar)
563255	INDICATOR, reset assy 1000 psi (6.89 MPa, 68.95 bar)
556429	FITTING, zerk, 1/8 nptf
556402	FITTING, 1/4 x 1/8 nptf hex

Part	Description
557969	CAP, dust
556420	FITTING, tee stl 1/4 npt male run
102814	GAUGE, 3000 psi (20.68 MPa, 206.8 bar) 1/4npt b/m dry
556407	FITTING, tee stl 1/4 nptf male
557950	BULKHEAD, remote fill
15M045	FITTING, elbow
557896	STUD, fill, 1/4 inch NPTF (f)
556408	FITTING, 1/4 x 1/8 inch NPTF Hex
555749	CONNECTOR, #4, JIC, 1/8 PM
15K783	FITTING, elbow
556762	1/4 x -4 JIC straight
557944	P-Clamps
127515	P-Clamp 1.5 inch
17K063	Zip-ties
17D688	Add-a-fuse
557264	5-amp ATM fuse
17G145	KIT, guarding
17K061	ELBOW, street
17G422	EXTENSION, short
17K062	EXTENSION, long
126218	CABLE, 15 foot, 5 pin

NOTE: Photographs may include optional equipment.

For additional information about these Graco products; including Warnings, Troubleshooting, and Technical Data refer to the Graco instruction manuals included with the equipment or visit the Graco website at www.graco.com to download the latest versions of Graco instruction manuals.