

24M433 Installation Fixture Kit

3A2236B

EN

To enable installation of a position sensor on Series C and earlier E-Flo Pumps, to allow use with the Graco ACS Module. Also requires 24J305 Sensor Circuit Kit and new style motor coupler with five position sensing holes. See Related Manuals, below.
For professional use only.



Important Safety Instructions

Read all warnings and instructions in this manual and in your E-Flo instruction manuals. Save these instructions.

Related Manuals

Manual	Description
311594	E-Flo Pump Repair-Parts Manual
311603	24J305 Sensor Circuit Kit Manual
311605	16C487 and 15H880 Motor Coupler Kits
3A0006	24H372 ACS Module Instruction Manual

Kit Parts

The following parts are included in the kit.

Description	Qty
FIXTURE, drill guide	1
DRILL BIT; 16.5 mm diameter x 223 mm	1
TAP, metric thread; M18 x 1.5	1

Installation

Motor Removal

1. Jog the motor to bring the lower on the side opposite from the motor to the bottom of its stroke.
2. Relieve pressure as explained in your E-Flo Pump Repair-Parts Manual.
3. Shut off electrical power to the unit.
4. Remove the motor as explained in your E-Flo Pump Repair-Parts Manual. Retain the motor mounting screws.
5. See FIG. 1. Loosen both coupler setscrews (31). Insert the 15J827 coupler removal tool (T) into the coupler (28). Turn nut clockwise until tight, then pull the coupler off the gear reducer input shaft (105) by turning hex-head screw (HS) clockwise.

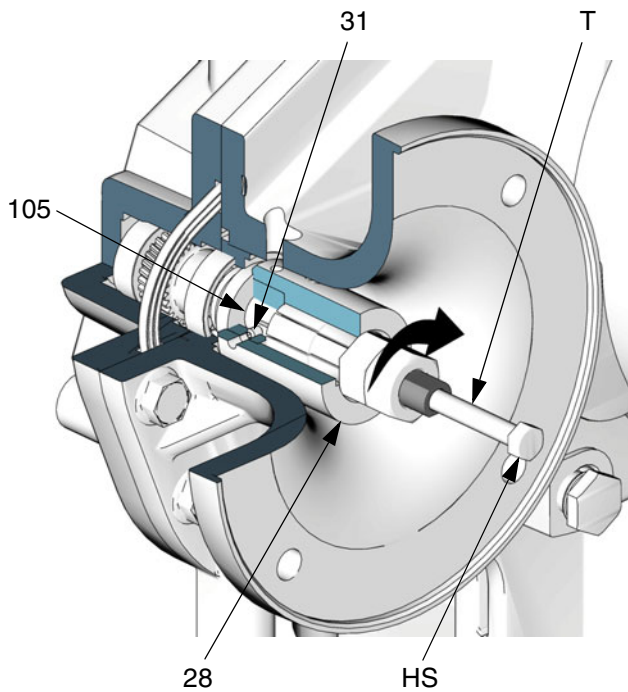

T18743b

FIG. 1. Motor Coupler Removal

Drill the Position Sensor Hole

The drill guide ensures that the position sensor mounting hole is properly located in the gear reducer housing.

1. See FIG. 2. Align the holes in the drill guide (DG) with the holes in the gear reducer flange (GR). Orient the guide as shown, then install using the motor mounting screws (MS).

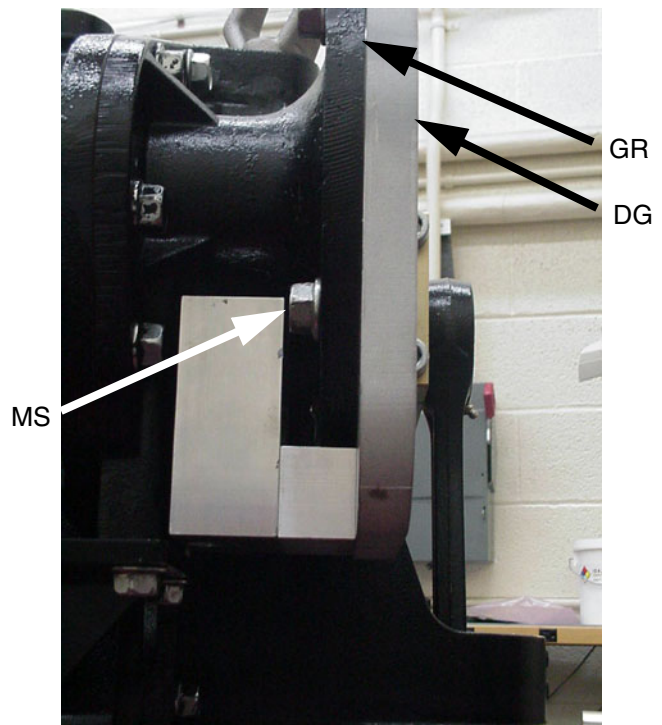

FIG. 2. Install the Drill Guide

2. See FIG. 3. Use the drill guide and a 16.5 mm diameter x 223 mm long tap drill bit to drill the hole for the position sensor in the gear reducer housing.



FIG. 3. Drill the Hole for the Position Sensor

3. See FIG. 4. Remove the drill guide. Tap the mounting hole, using a M18 x 1.5 thread tap.

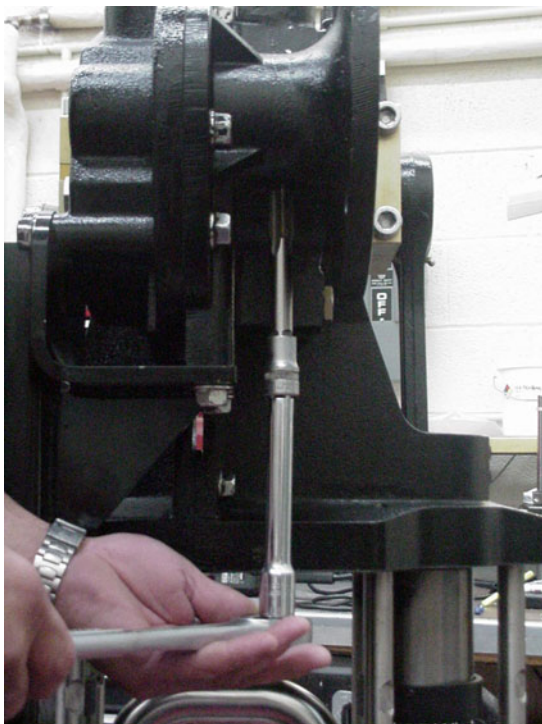

FIG. 4. Tap the Mounting Hole

Install the Coupler

See FIG. 5 on page 4. The position sensor requires a new style coupler with five machined sensing holes (H). See manual 311605 to select the correct coupler for your motor frame, and install the coupler as directed.

Install the Sensors

See manual 311603 for complete instructions to install the 24J305 Sensor Circuit Kit.

1. Remove the existing TDC sensor and install the new sensor supplied in the sensor circuit kit.
2. Remove the existing pressure transducer, conduit, conduit nut, and transducer adapter.
3. Slide the new transducer adapter onto the transducer cable. The new adapter has larger threads which fit the nut on the new conduit.
4. See FIG. 5 on page 4. Slide the position sensor sleeve (S) onto the position sensor (P) cable.
5. Thread the transducer cable into the short leg of the new conduit. Thread the position sensor cable into the long leg of the conduit.
6. Continue threading both cables through the conduit until they exit. Insert the conduit into the 45° adapter at the pump wiring enclosure, and bring both cables into the enclosure.
7. Install the new transducer and adapter into the pump outlet manifold. Secure with the conduit nut.

Installation

8. See FIG. 5. Apply thread lubricant and install the position sensor adapter (A) into the tapped hole. Torque to 75-80 ft-lb (102-108 N•m).

1 Apply thread lubricant. Torque to 75-80 ft-lb (102-108 N•m).

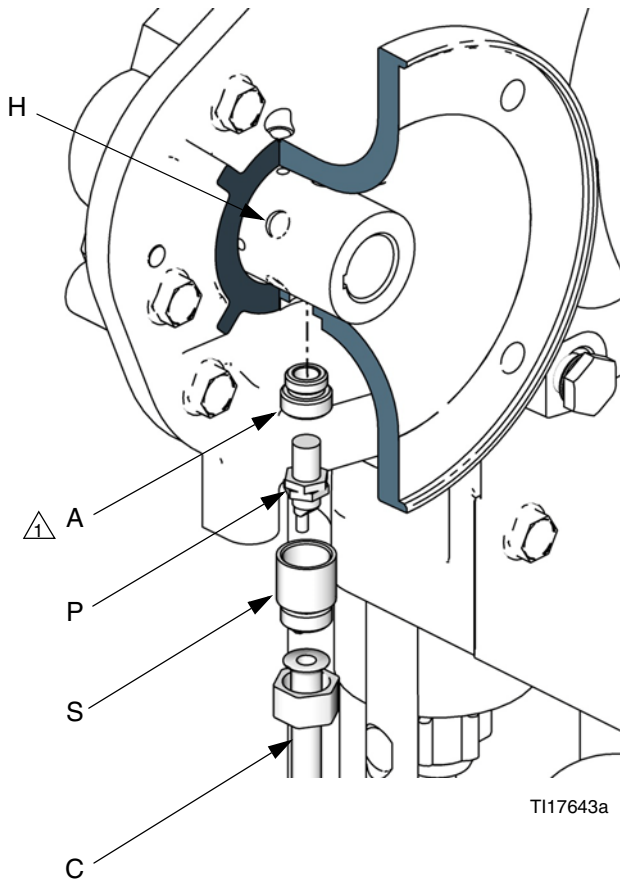

FIG. 5. Install the Position Sensor

9. See FIG. 6. Loosen the jam nuts of the position sensor (P). Adjust the position of the sensor so there is a 1.0-1.2 mm gap between the sensor tip and the coupler. Verify the distance with a feeler gauge (G) or a set of pin gauges, then tighten the jam nuts and sleeve (S) to lock the sensor in place.

10. Secure the conduit (C) to the sleeve (S) with the nut (M). Torque to 15-20 ft-lb (21-27 N•m).

2 Torque to 15-20 ft-lb (21-27 N•m).

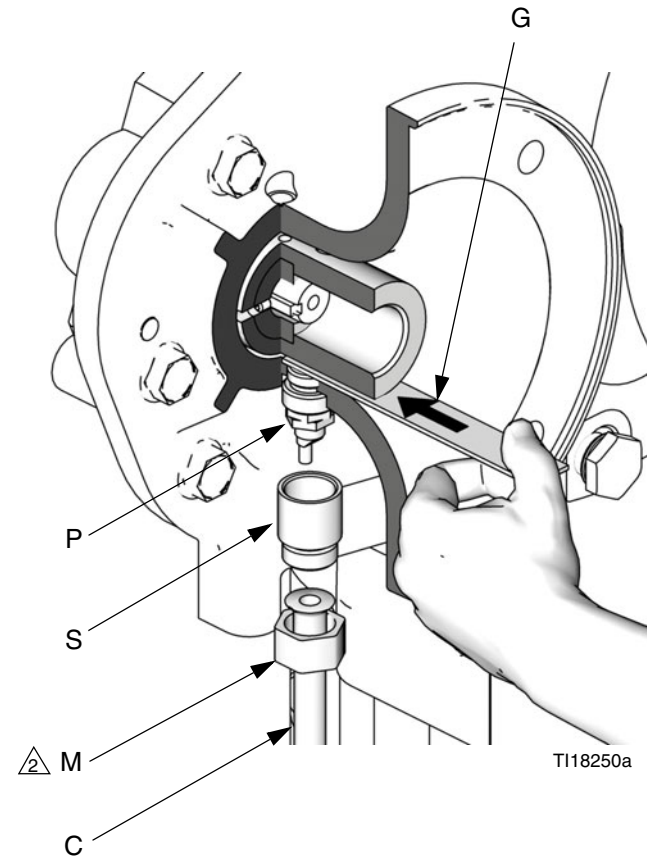

FIG. 6. Measure 1.0-1.2 mm Gap from Sensor to Coupler

11. Wire the TDC, pressure transducer, and position sensor cables to the board as described in manual 311603.
12. Complete the proper grounding of the pressure transducer and field wiring to the pump wiring enclosure, as shown in manual 311603.
13. Complete the wiring of the position sensor to field wiring, using the spring-loaded terminal blocks supplied.
14. Close the wiring enclosure. Reinstall the motor and all covers.
15. Restore power and return the pump to service.

IMPORTANT: Verification of Sensor Placement.

Once the E-Flo/ACS system is operating, run the pump at a constant speed. Use a volt/ohm meter with a frequency/percent output feature (or a scope) to ensure that the position sensor is operating in a 25-35% on duty range. Take this measurement at the output of the barrier (see the Electrical Diagrams in your E-Flo Repair-Parts manual). This duty range ensures proper sensor location and alignment.

If the duty cycle is outside the 25-35% on range, readjust the position sensor as follows. (See step 9 for the adjustment procedure.)

- If the duty cycle is less than 25% on, move the sensor further away from the coupler.
- If the duty cycle is more than 35% on, move the sensor closer to the coupler.

NOTE: Move the sensor in increments no greater than 0.25 mm. Be careful not to contact the coupler.

Graco Standard Warranty

Graco warrants all equipment referenced in this document which is manufactured by Graco and bearing its name to be free from defects in material and workmanship on the date of sale to the original purchaser for use. With the exception of any special, extended, or limited warranty published by Graco, Graco will, for a period of twelve months from the date of sale, repair or replace any part of the equipment determined by Graco to be defective. This warranty applies only when the equipment is installed, operated and maintained in accordance with Graco's written recommendations.

This warranty does not cover, and Graco shall not be liable for general wear and tear, or any malfunction, damage or wear caused by faulty installation, misapplication, abrasion, corrosion, inadequate or improper maintenance, negligence, accident, tampering, or substitution of non-Graco component parts. Nor shall Graco be liable for malfunction, damage or wear caused by the incompatibility of Graco equipment with structures, accessories, equipment or materials not supplied by Graco, or the improper design, manufacture, installation, operation or maintenance of structures, accessories, equipment or materials not supplied by Graco.

This warranty is conditioned upon the prepaid return of the equipment claimed to be defective to an authorized Graco distributor for verification of the claimed defect. If the claimed defect is verified, Graco will repair or replace free of charge any defective parts. The equipment will be returned to the original purchaser transportation prepaid. If inspection of the equipment does not disclose any defect in material or workmanship, repairs will be made at a reasonable charge, which charges may include the costs of parts, labor, and transportation.

THIS WARRANTY IS EXCLUSIVE, AND IS IN LIEU OF ANY OTHER WARRANTIES, EXPRESS OR IMPLIED, INCLUDING BUT NOT LIMITED TO WARRANTY OF MERCHANTABILITY OR WARRANTY OF FITNESS FOR A PARTICULAR PURPOSE.

Graco's sole obligation and buyer's sole remedy for any breach of warranty shall be as set forth above. The buyer agrees that no other remedy (including, but not limited to, incidental or consequential damages for lost profits, lost sales, injury to person or property, or any other incidental or consequential loss) shall be available. Any action for breach of warranty must be brought within two (2) years of the date of sale.

GRACO MAKES NO WARRANTY, AND DISCLAIMS ALL IMPLIED WARRANTIES OF MERCHANTABILITY AND FITNESS FOR A PARTICULAR PURPOSE, IN CONNECTION WITH ACCESSORIES, EQUIPMENT, MATERIALS OR COMPONENTS SOLD BUT NOT MANUFACTURED BY GRACO. These items sold, but not manufactured by Graco (such as electric motors, switches, hose, etc.), are subject to the warranty, if any, of their manufacturer. Graco will provide purchaser with reasonable assistance in making any claim for breach of these warranties.

In no event will Graco be liable for indirect, incidental, special or consequential damages resulting from Graco supplying equipment hereunder, or the furnishing, performance, or use of any products or other goods sold hereto, whether due to a breach of contract, breach of warranty, the negligence of Graco, or otherwise.

FOR GRACO CANADA CUSTOMERS

The Parties acknowledge that they have required that the present document, as well as all documents, notices and legal proceedings entered into, given or instituted pursuant hereto or relating directly or indirectly hereto, be drawn up in English. Les parties reconnaissent avoir convenu que la rédaction du présente document sera en Anglais, ainsi que tous documents, avis et procédures judiciaires exécutés, donnés ou intentés, à la suite de ou en rapport, directement ou indirectement, avec les procédures concernées.

Graco Information

For the latest information about Graco products, visit www.graco.com.

TO PLACE AN ORDER, contact your Graco distributor or call to identify the nearest distributor.

Phone: 612-623-6921 **or Toll Free:** 1-800-328-0211 **Fax:** 612-378-3505

All written and visual data contained in this document reflects the latest product information available at the time of publication. Graco reserves the right to make changes at any time without notice.

Original instructions. This manual contains English. MM 3A2236

Graco Headquarters: Minneapolis
International Offices: Belgium, China, Japan, Korea

GRACO INC. AND SUBSIDIARIES • P.O. BOX 1441 • MINNEAPOLIS MN 55440-1441 • USA

Copyright 2011, Graco Inc. All Graco manufacturing locations are registered to ISO 9001.

www.graco.com
Revised 01/2012