

Linear Sensor Kits

For NXT® Air Motors

406903A

ENG



Important Safety Instructions

Read all warnings and instructions in your air motor manual. Save all instructions.

Kit 24G848, M04xxx - M18xxx Air Motors, IS Kit 24G850, M04xxx - M18xxx Air Motors, Non IS

Ref.	Part	Description	Qty.
101	24C404	SENSOR, assembly	1
102	-----	BUSHING	1
103	-----	O-RING	1
104	-----	MAGNET, with holder	1
105	-----	LOCTITE	1

Kit 24G849, M02LH0 Air Motor, IS Kit 24G851, M02LH0 Air Motor, Non IS

Ref.	Part	Description	Qty.
101	24C404	SENSOR, assembly	1
102	-----	BUSHING	1
103	-----	O-RING	1
105	-----	LOCTITE	1

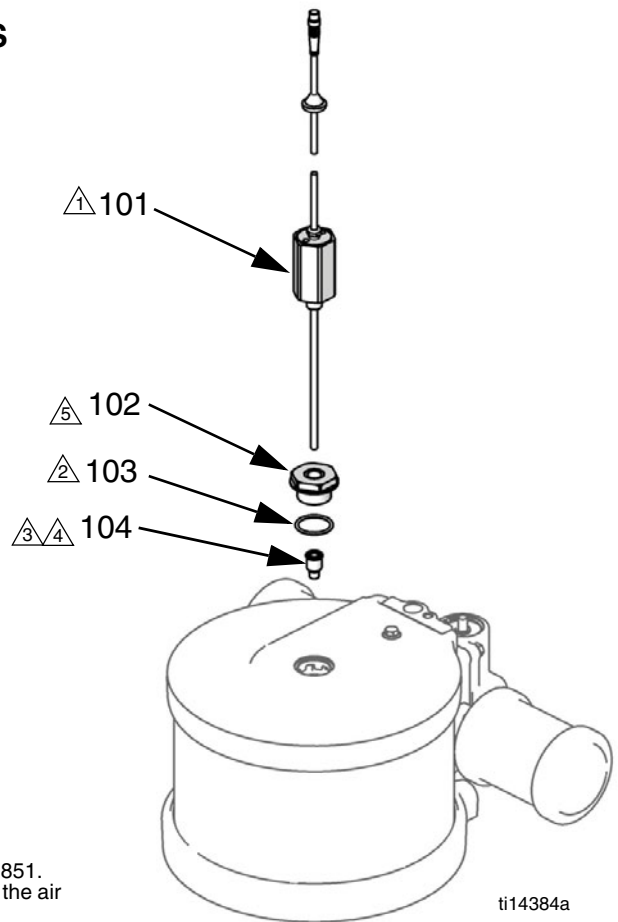

- ① Apply Loctite (105, supplied).
- ② Apply lubricant.
- ③ Press to snap fit.
- ④ Not included in Kits 24G849 and 24G851. The magnet is factory installed inside the air motor on Model M02LH0 air motors.
- ⑤ Bushing shown is used on Kits 24G848 and 24G850. Kits 24G849 and 24G851 use a different bushing, but function is the same.

ti14384a

Graco Inc. P.O. Box 1441 Minneapolis, MN 55440-1441

Original instructions. This manual contains English. MM 406903

Copyright 2010, Graco Inc. is registered to ISO 9001