

Solenoid Valve Installation Kit

312929D
ENG

To pressurize and depressurize the single diaphragm pump in Grease Jockey automatic lubrication systems. For professional use only.

Part No.: 24E017 - 24VDC

Part No.: 563641 - 12 VDC



Important Safety Instructions

Read all warnings and instructions in Operation manual 312054. Save all instructions.

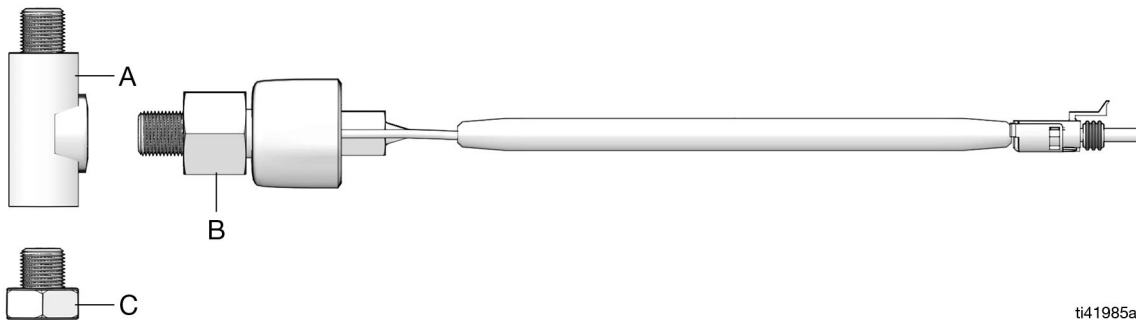

ti41985a

Parts List

Ref	Description	Qty
A	1/4 MP x 1/4 FP (2) Tee	1
B	Solenoid Assy 557932 used in 563641	1
	Solenoid Assy 557931 used in 24E017	1
C	1/4 NPT plug	1

Solenoid Removal

(See Fig. 1)

1. Relieve pressure in air line to solenoid and disconnect air line.
2. Disconnect electrical connector (D).
3. Remove solenoid assembly from bottom of the pump using an open end wrench on fitting (A).
4. Discard assembly.

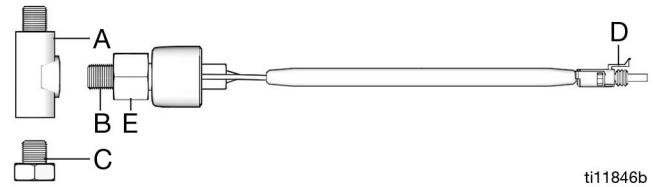

ti11846b

FIG. 1

Solenoid Installation

(Unless otherwise indicated, see Fig. 1)

Be sure you have the correct voltage to match your vehicle's electrical system.

1. Apply thread sealant to fitting threads (A).
2. Thread fitting (A), to the bottom of the pump. Hand tighten only.
3. Use an open end wrench to tighten fitting. Side port of fitting must point toward rear of vehicle.
4. Apply thread sealant to solenoid threads (B).

5. Thread solenoid (B) to the side port on fitting (A). Wrench tighten.
6. Apply thread sealant to plug threads (C).
7. Thread plug (C), to the bottom of fitting (A). Wrench tighten.
8. Reconnect air line to port (E).
9. Attach electric connector to (D).

The completed installation should look like FIG. 2.

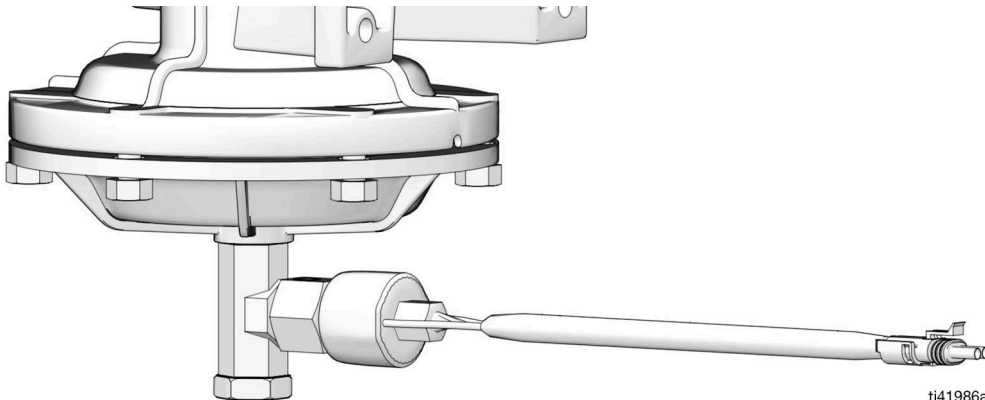

ti41986a

FIG. 2

All written and visual data contained in this document reflects the latest product information available at the time of publication. Graco reserves the right to make changes at any time without notice.

Original instructions. This manual contains English. MM 312929

Graco Headquarters: Minneapolis

International Offices: Belgium, China, Japan, Korea

GRACO INC. P.O. BOX 1441 MINNEAPOLIS, MN 55440-1441

Copyright 2008, Graco Inc. is registered to ISO 9001

www.graco.com

Revision D, July 2022