

## Lacquer Conversion Kit 248202

310724G



### Important Safety Instructions

Read all warnings and instructions in this manual and in the sprayer Operation manual. Save these instructions.

### Pressure Relief Procedure



To help prevent injection injuries, follow this procedure when you stop spraying and before you service or clean the sprayer, remove parts, or repair leaks.

1. Turn power switch OFF. Unplug sprayer.
2. Turn Spray/Prime valve to PRIME to relieve pressure. Turn Pressure Control knob left (counterclockwise) to minimize pressure.
3. Trigger gun.
4. Put trigger safety in safety ON position.

**NOTE:** Leave Spray/Prime valve in PRIME position until you are ready to spray again.

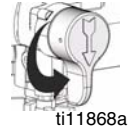

If you suspect that the spray tip or hose is completely clogged or that pressure has not been fully relieved after following the steps above, VERY SLOWLY loosen the tip guard retaining nut or hose end coupling to relieve pressure gradually. Then loosen it completely. Clear the tip or hose obstruction.

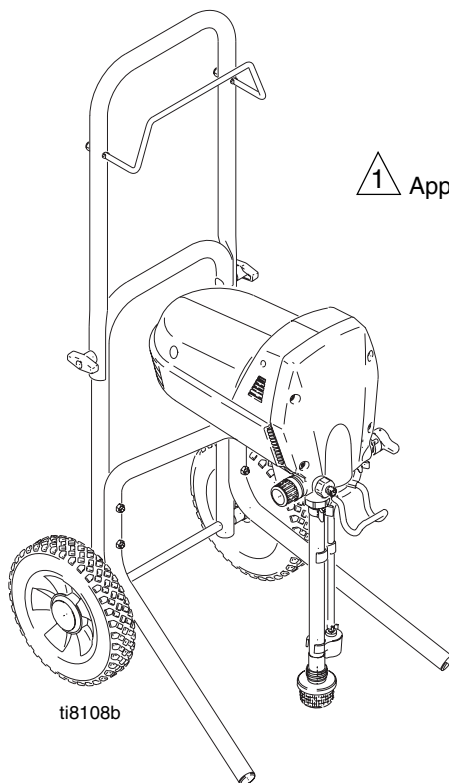

1 Apply light coat of lithium-based grease

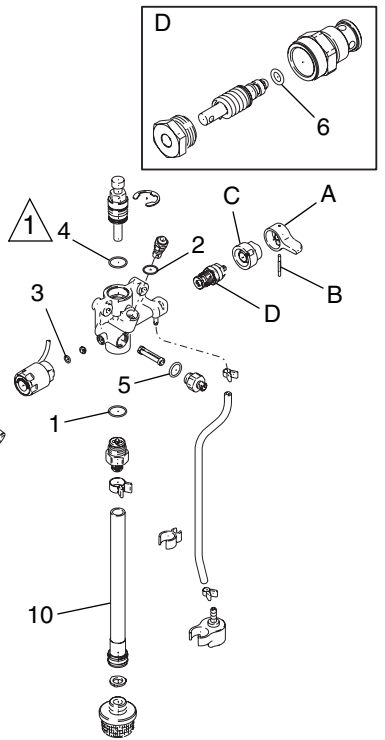

Ref.	Part	Description	Qty.
1	117559	O-RING, CV-75, size 020	1
2	111507	O-RING, CV-75, size 013	1
3	111316	O-RING, CV-75, size 012	1
4	15D370	O-RING, CV-75, size 022	1
5	15D371	O-RING, CV-75, size 015	1
6	15D252	O-RING, CV-90, size 008	1
9	119400	SEALANT, pipe, sst	1
10	15D883	TUBE, suction	1

# Lacquer Conversion Kit

## Instructions

### 1. To **Relieve Pressure**:

- a. Turn power switch OFF.
- b. Unplug sprayer.
- c. Turn Spray/Prime knob (A) down.
- d. Hold metal part of gun firmly to a grounded metal pail. Pull gun trigger to relieve pressure.

2. Turn knob (A) up to spray position.

3. Remove pin (B) with 3/32 pin punch and hammer.

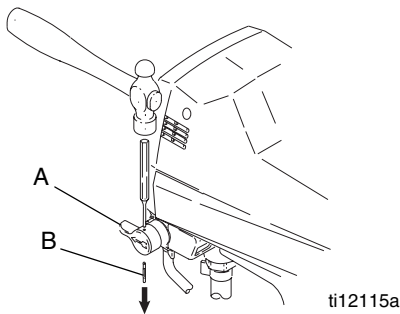

4. Remove knob (A) and base (C).

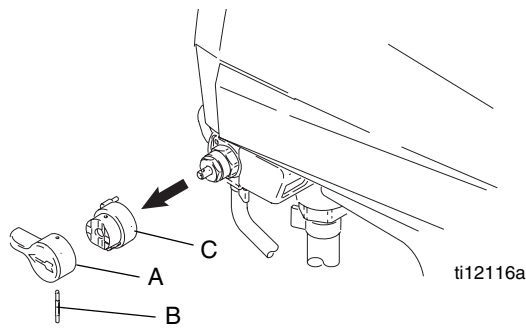

5. Remove valve stem (D) from manifold. Be sure gasket (8) and seat (7) do not stay in manifold.

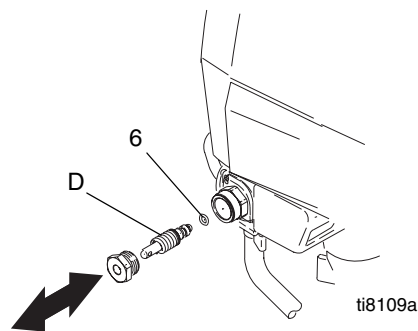

6. Replace brown o-ring (6) on end of valve stem. Apply sealant (9) to valve threads. Install valve stem in pump manifold. Torque to 185 in-lb (21 N•m).

7. Install base (C) on valve. Align pin (E) on base (C) with hole (F) on manifold.

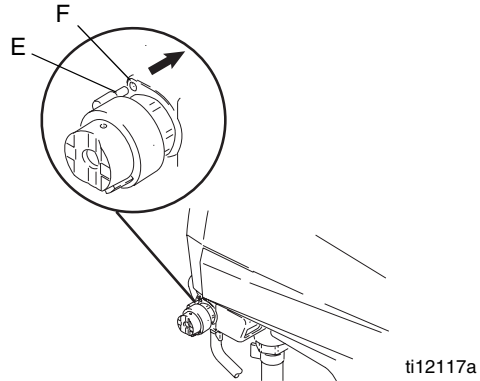

8. Rotate valve stem with a 3/32 pin punch until hole is perpendicular.

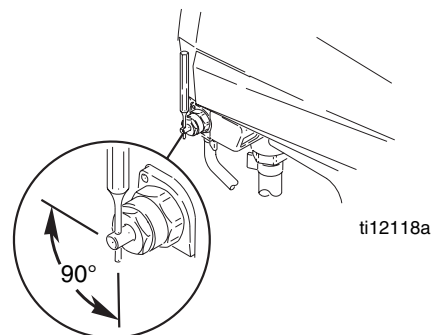

9. Install knob (A) over base (C).

10. Place knob in spray position.

11. Insert end of pin punch through hole in knob (A) to make sure knob valve and stem are aligned.

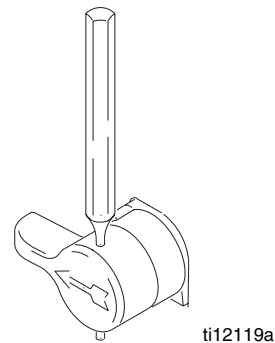

12. Install pin (B) through hole in knob (A). Tap pin through knob with hammer. Correctly installed, end of pin is flush with top of hole in knob.

# Pressure Control Switch

## Disassembly

1. Unplug electrical cord and **Relieve Pressure** (see **Pressure Relief Procedure** on page 1).
2. Remove cover screws (A) and front cover (B).
3. Remove yoke (C) and guide rods (D).
4. Disconnect pressure control wire harness (E) from control board connector at back of drive housing (F).

## Installation

- Before you begin reassembly, read all Installation Notes on page 4. For more information, refer to assembly illustration, also on page 4.
1. Examine new pressure control switch (H) to verify o-ring seal (J) is in place. If it is not installed on pressure control switch, install o-ring seal.
  2. Apply thread locker (included in kit) to threads of pressure control switch (H). Screw new pressure control switch into pump (G), and torque to 140 to 160 in-lb (16 to 18 N•m). **Do not overtighten or damage could occur.**
  3. Route pressure control wiring harness (E) through retention clip (K) and connect to control board connector at back of drive housing (F).
  4. Secure wires in place by closing retention clip securely over wires.
  5. Install pump (G) on mounting pin (L). Make sure the plastic washers (M) are between the drive housing (F) and the pump (G) and that the pressure control wires (E) are not pinched between pump and drive housing.
  6. Install yoke (C) with rod cap in slot of yoke, as shown in Rod/Yoke Detail on page 4.
  7. Check final assembly against Drive Train Detail on page 4.

Use fingernail or tip of small flat-blade screwdriver to press tab on right side of connector to release.

5. Remove pump (G) from drive housing (F).
6. Place pump (G) on workbench or in vise.
7. Unscrew pressure control switch knob (H). Verify the o-ring seal (J) also is removed from pump.
8. Install front cover (B) and cover screws (A). Torque to 110 to 120 in-lb (12.4 to 13.6 N•m).
9. Apply arrow indicator label (N) to front cover (B) as shown below.
10. Turn pressure control switch knob (H) fully clockwise. Apply pressure control label (P) to switch knob.

To position label correctly, see note below:

 When properly positioned, the arrow indicator label (N) and hi-spray position symbol on pressure control label (P) are aligned.

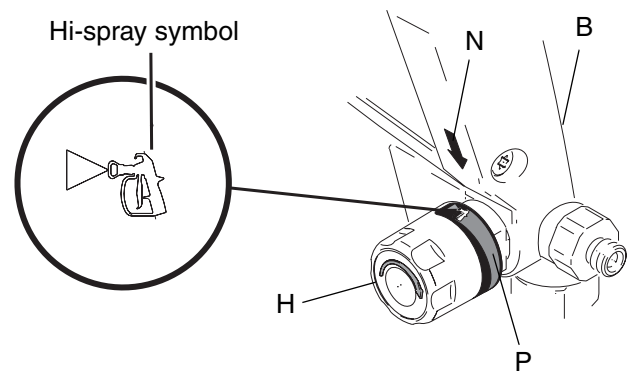

## Pressure Control Replacement

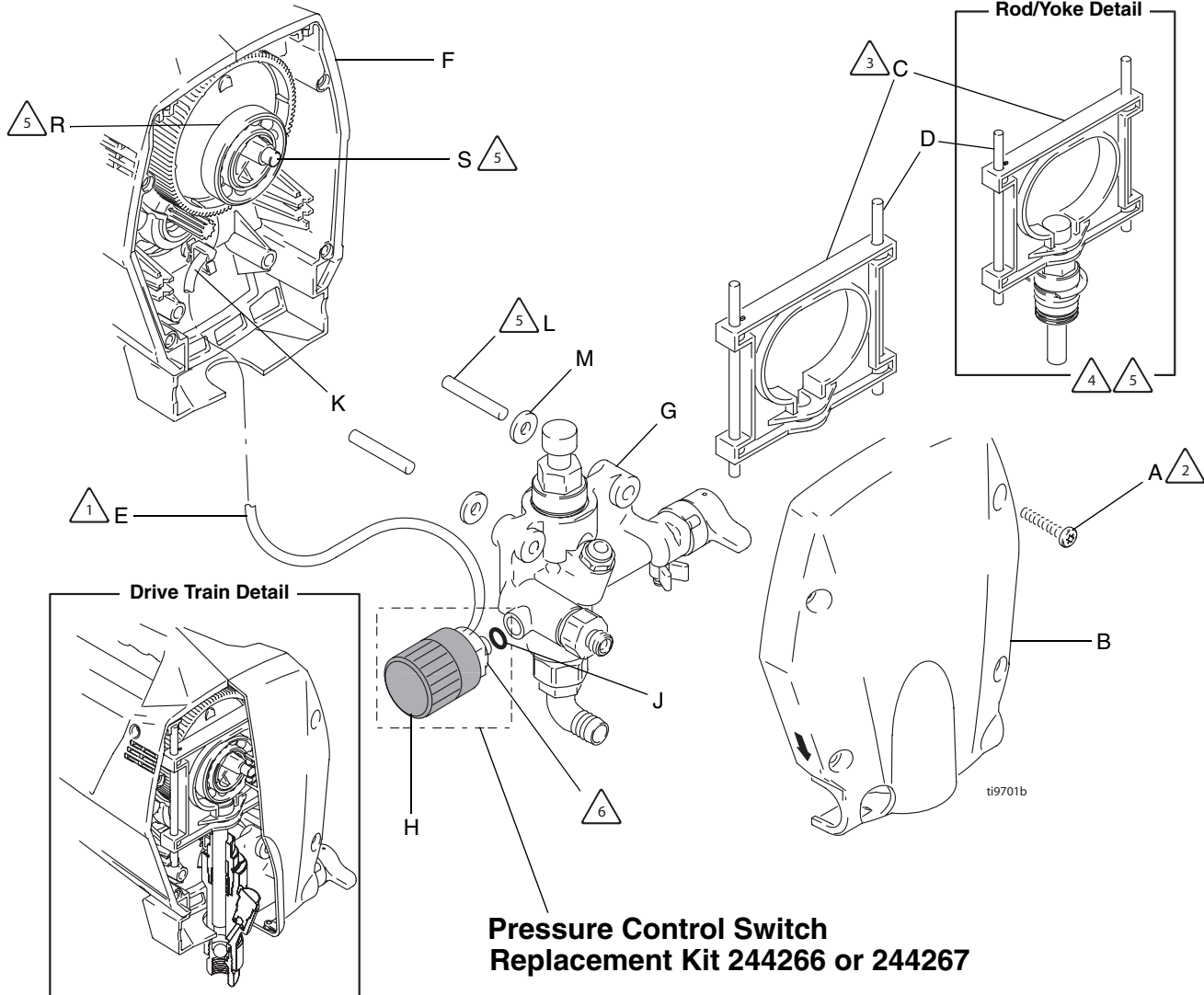

**Pressure Control Switch  
Replacement Kit 244266 or 244267**

### Installation Notes

To prevent misalignment, assemble with sprayer tipped onto back of enclosure.

- 1 Take care to not pinch wiring harness (E) between pump (G) and any part of drive housing (F) or between front cover (B) and drive housing. Use a needle-nose pliers to remove harness.
- 2 For best cover (B) alignment, tighten lower two cover screws (A) first, then top two. Torque screws to 110-120 in.-lb (12.4-13.6 N•m).
- 3 For yoke (C) installation, bearing (R) on gear (S) must touch top of pump rod. Turn gear to move bearing to proper height.
- 4 If yoke guide rods (D) drop out of position during assembly, damage will occur when cover (B) is tightened. Always check position of guide rods before tightening cover.
- 5 Apply light coat of oil.
- 6 Apply one or two drops of thread locking adhesive (included in kit) to threads of pressure control switch (H). Torque to 140-160 in.-lb (16-18 N•m).



*All written and visual data contained in this document reflects the latest product information available at the time of publication.  
Graco reserves the right to make changes at any time without notice.*

*This manual contains English. MM 310724*

**Graco Headquarters:** Minneapolis

**International Offices:** Belgium, China, Japan, Korea

**GRACO INC. P.O. BOX 1441 MINNEAPOLIS, MN 55440-1441**

Copyright 2008, Graco Inc. is registered to I.S. EN ISO 9001

[www.graco.com](http://www.graco.com)

Revised 4/2008