

Instructions - Parts



# Communications Gateway Module

## Therm-O-Flow<sup>®</sup> Installation Kit

3A5186C

EN

*For use with Therm-O-Flow 20 and 200 systems to provide fieldbus communication capabilities. For professional use only.*

**Kit No. 25C994**



### **Important Safety Instructions**

Read all warnings and instructions in this manual and in all related manuals. Save all instructions.

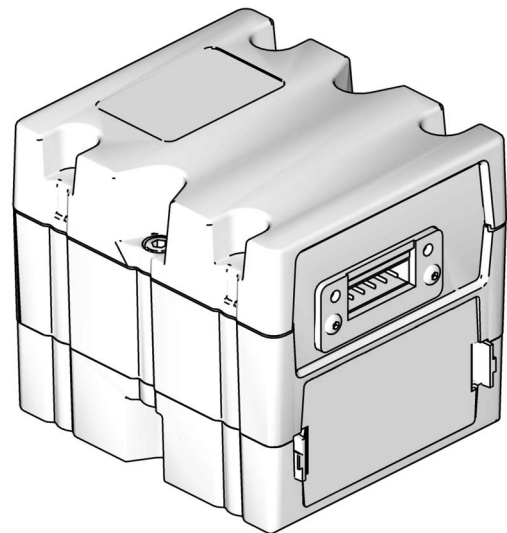

PROVEN QUALITY. LEADING TECHNOLOGY.

# Contents

**Related Manuals** ..... 2

**Models** ..... 2

**Overview** ..... 2

**Installation** ..... 3

    Mounting the CGM ..... 3

    Connecting the CAN Cables ..... 3

**Setup** ..... 5

    Gateway Screens ..... 5

    EtherNet/IP Fieldbus Screens ..... 5

    DeviceNet Fieldbus Screen ..... 5

    PROFIBUS Fieldbus Screen ..... 6

    PROFINET Fieldbus Screens ..... 6

**Maintenance** ..... 8

    Software Update Procedure ..... 8

**Available Internal Data** ..... 9

    Automation Inputs (Signals from the Therm-O-Flow to the PLC) ..... 9

    Automation Outputs (Signals from the PLC to the Therm-O-Flow) ..... 11

**Parts** ..... 12

    Kit No. 25C994 ..... 12

**Appendix A - I/O Signal Descriptions** ..... 13

    Heat Zone States ..... 13

    Status Indication Bit Tables ..... 13

    System Control Bits ..... 14

    Temperature Setpoint Zone Designation Table ..... 16

**Appendix B - Data Exchange Interface** ..... 17

    Data Exchange Interface Pointer Designation Table ..... 18

**Appendix C - Error/Event Tables** ..... 22

# Related Manuals

Manual	Description
312864	Communications Gateway Module Instructions - Parts
334130	Therm-O-Flow 200 Instructions - Parts
334129	Therm-O-Flow 20 Instructions - Parts
406987	GCA CAN Cables, Reference

# Models

The following kit includes the Communications Gateway Module (CGM) parts and software that are required for Therm-O-Flow 20 or Therm-O-Flow 200 machines using a CGM. This kit enables the Therm-O-Flow machines to connect to a fieldbus device.

Part No.	Description
25C994	Thermo-O-Flow CGM Installation Kit

Kit 25C994 is used with the following CGM models, each of which includes all of the remaining parts necessary to install the CGM. See *Communications Gateway Module Instructions - Parts*, manual 312864, for repair parts for these assemblies.

Part No.	Fieldbus
CGMEP0	EtherNet/IP
CGMDN0	DeviceNet
CGMPB0	PROFIBUS
CGMPN0	PROFINET

# Overview

The Communications Gateway Module (CGM) provides a control link between the Therm-O-Flow (TOF) system and a selected fieldbus. The control link provides the means for remote monitoring and control by external automation systems.

The data available to the fieldbus from the CGM depends on the amount of channels installed on the Therm-O-Flow system. A data map is available on a token provided in this kit.

See **Available Internal Data** on page 9 for a list of internal data from the Therm-O-Flow system that can be viewed or modified by the fieldbus device.

**NOTE:** The following system network configuration files are available at [www.graco.com](http://www.graco.com).

- EDS file: DeviceNet or Ethernet/IP fieldbus networks

# Installation

**NOTE:** Turn off the main power switch on the Therm-O-Flow before starting. See the Therm-O-Flow manuals referenced in **Related Manuals** on page 2 for information about turning off the power.

To install the CGM, you will need to drill mounting holes on the Therm-O-Flow below the electrical control panel in a location where the CAN cables can be connected to the CGM. See Figure 1 for the recommended location.

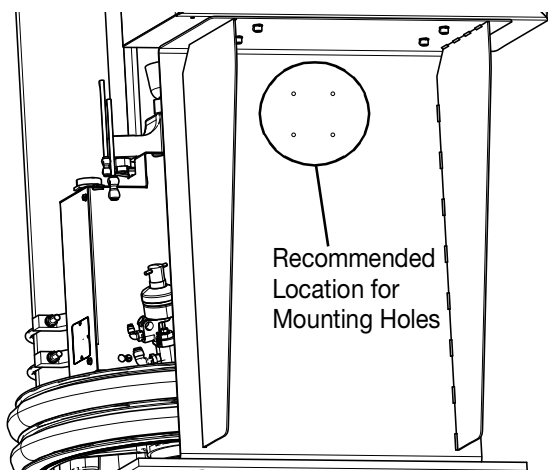

**FIG. 1: Mounting Location**

The center of the CGM should be 4 inches from the bottom of the electrical control panel and 8 inches from each side. Refer to the following mounting dimensions when drilling the holes for the CGM.

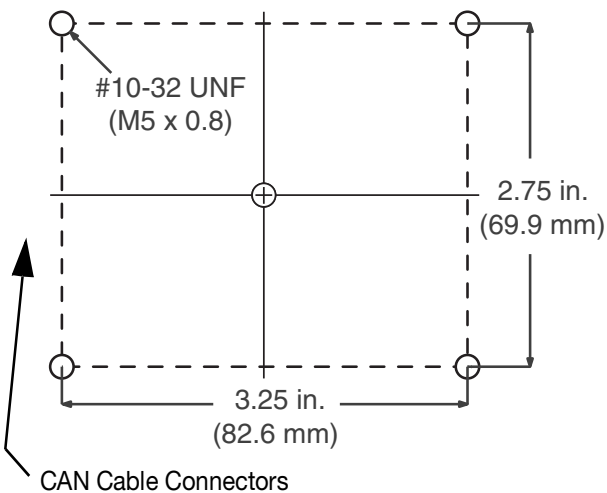

**NOTE:** Mount the CGM with the CAN cable connectors on the left side to make it easier to connect the cables.

## Mounting the CGM

1. Drill the mounting holes.
2. Remove the access cover from the CGM (D). Loosen the two screws (C) and remove the CGM (A) from the base (B).

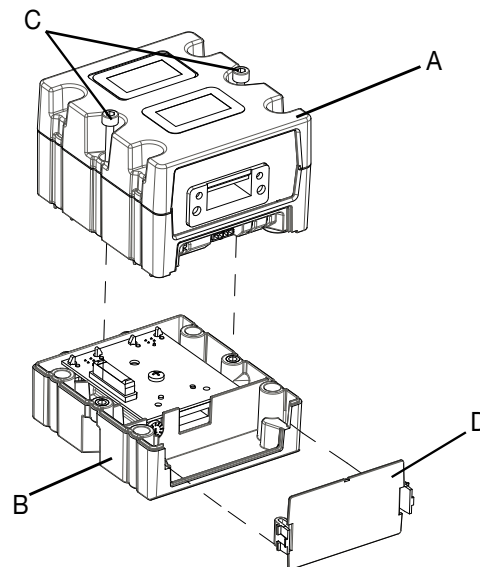

**FIG. 2: Removing the CGM Access Cover**

3. With the CAN connectors on the left side, mount the base (B) in the mounting holes using the four screws supplied in this kit. See **Parts** on page 12.
4. Mount the CGM (A) on the base (B) with the two screws (C) that were removed in step 2.
5. Reattach the access cover (D).

## Connecting the CAN Cables

1. Disconnect the ADM's CAN cable from the ADM and from the splitter on the back of the Therm-O-Flow's electrical control panel.
2. Connect one end of the 1.5 m (4.9 ft) CAN cable included in this kit to the ADM. Run the cable down and through the opening underneath the electrical control box as shown in Figure 3.

3. Connect the CAN cable that you removed from the ADM to the available splitter connection on the back of the electrical control panel. Run that cable through the same opening as the other CAN cable.

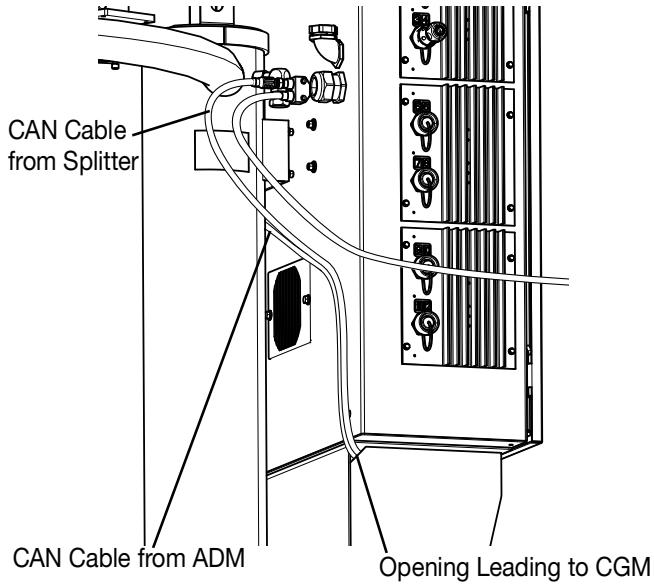

**Fig. 3: CAN Cable Connection**

4. Connect the two cables to the CGM connectors. Either cable can be connected to either connector.

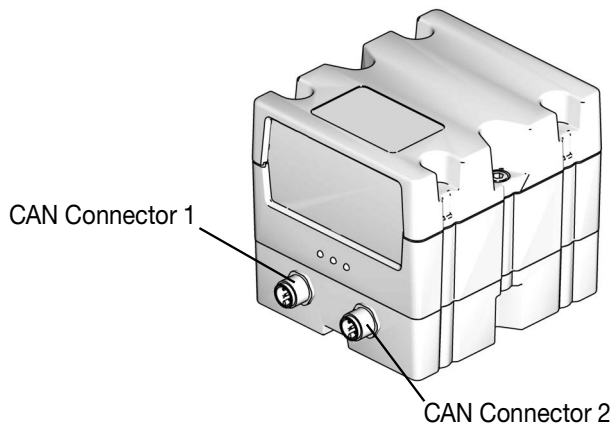

**Fig. 4: CGM Connectors**

5. Attach the two ferrite suppressors included in the kit to the ends of the two cables closest to the CGM.
6. Use the adhesive cable tie included in the kit to attach the CAN cables to the back of the control box.
7. Connect the Ethernet, DeviceNet, or PROFIBUS cable to the CGM as applicable. Connect the other end of the cable to the fieldbus device.

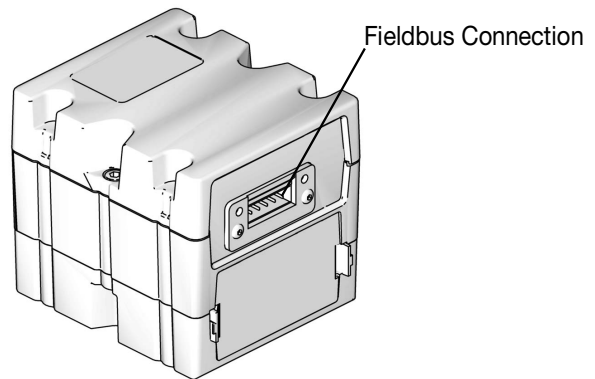

**Fig. 5: Connecting the Fieldbus**

8. Perform the Install or Update Data Map procedure in *Communications Gateway Module Instructions - Parts*, manual 312864.
9. See the **Available Internal Data** on page 9 for details on the fieldbus pinout setup.
10. Perform **Setup** on page 5 to configure the fieldbus.

# Setup

To prevent damage to soft key buttons on the ADM, do not press the buttons with sharp objects such as pens, plastic cards, or fingernails.

## Gateway Screens

Use the Gateway screens on the ADM to configure the fieldbus. These screens are shown only if a CGM is correctly installed in your system. See **Installation** on page 3.

1. With the system on and enabled, press  on the ADM to access the Setup screens.
2. Use the ADM's arrow keys to navigate to the main Gateway screen.

## EtherNet/IP Fieldbus Screens

**NOTE:** These screens are shown only if you have an EtherNet/IP fieldbus CGM installed.

### Screen 1

Press the  key to access this screen. Use the arrow keys to navigate to each field and the keypad to set the IP address, DHCP settings, subnet mask, gateway, and DNS information.

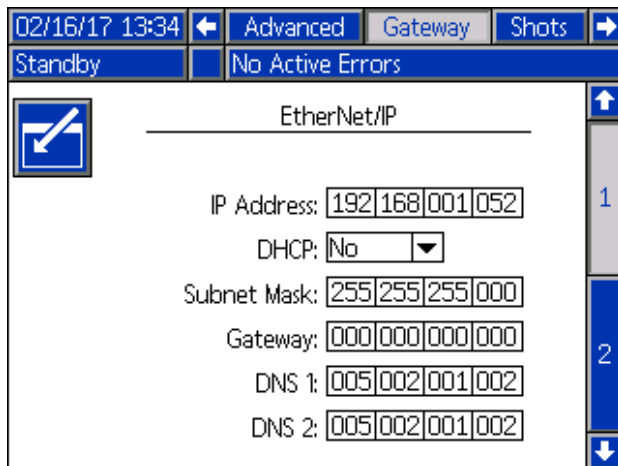

02/16/17 13:34 | Advanced | Gateway | Shots

Standby | No Active Errors

EtherNet/IP

IP Address: 192|168|001|052

DHCP: No

Subnet Mask: 255|255|255|000

Gateway: 000|000|000|000

DNS 1: 005|002|001|002

DNS 2: 005|002|001|002

### Screen 2

Use the down arrow key on the ADM to navigate to screen 2. This screen displays the hardware revision, system serial number, and data map identification information.

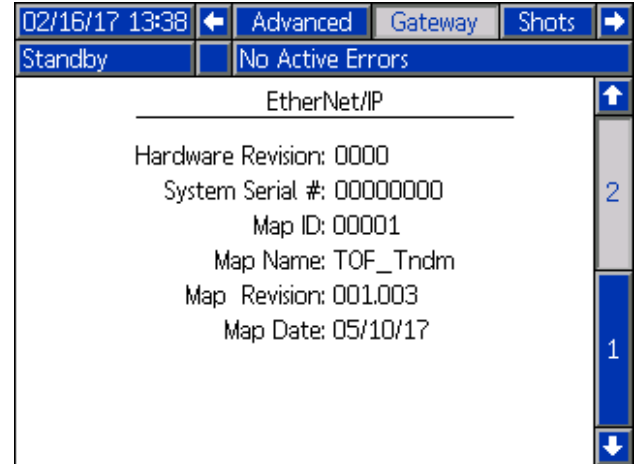

02/16/17 13:38 | Advanced | Gateway | Shots

Standby | No Active Errors

EtherNet/IP

Hardware Revision: 0000

System Serial #: 00000000

Map ID: 00001

Map Name: TOF\_Tndm

Map Revision: 001.003

Map Date: 05/10/17

## DeviceNet Fieldbus Screen

**NOTE:** This screen is shown only if you have a DeviceNet fieldbus CGM installed.

Press the  key to access this screen. You can set the device address and baud rate. You can also view the hardware revision, system serial number, and data map identification information.

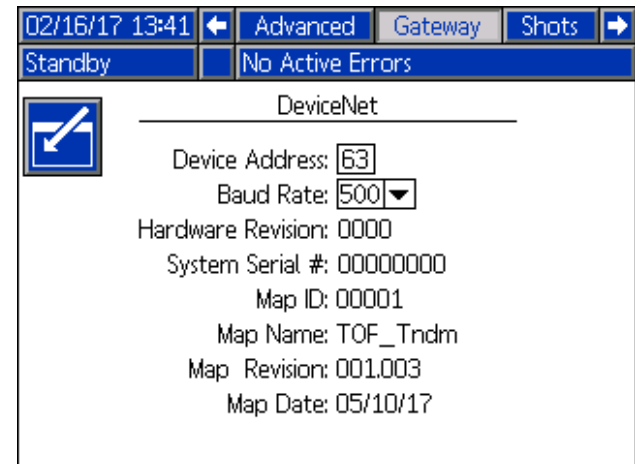

02/16/17 13:41 | Advanced | Gateway | Shots

Standby | No Active Errors

DeviceNet

Device Address: 63

Baud Rate: 500

Hardware Revision: 0000

System Serial #: 00000000

Map ID: 00001

Map Name: TOF\_Tndm

Map Revision: 001.003

Map Date: 05/10/17

## PROFIBUS Fieldbus Screen

**NOTE:** These screens are shown only if you have a PROFIBUS fieldbus CGM installed.

### Screen 1

Press the  key to access this screen. Use the arrow keys to navigate to each field and the keypad to set the device address, install date, location tag, function tag, and description.

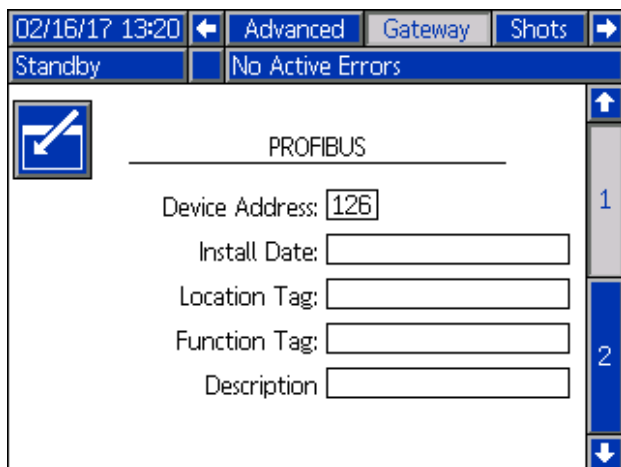

02/16/17 13:20 | Advanced | Gateway | Shots

Standby | No Active Errors

 PROFIBUS

Device Address:

Install Date:

Location Tag:

Function Tag:

Description:

1

2

### Screen 2

Use the down arrow key on the ADM to navigate to screen 2. This screen displays the hardware revision, system serial number, and data map identification information.

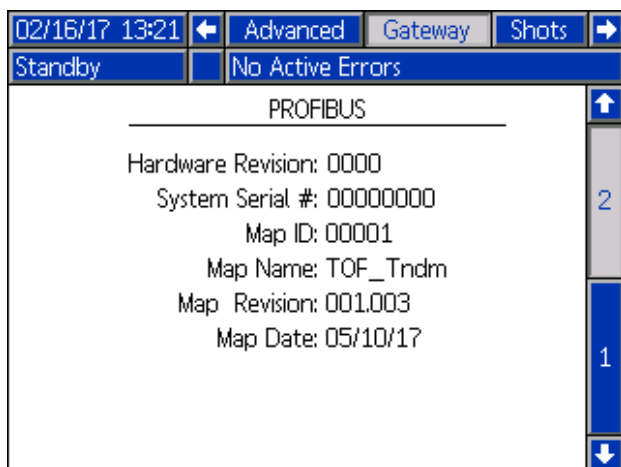

02/16/17 13:21 | Advanced | Gateway | Shots

Standby | No Active Errors

PROFIBUS

Hardware Revision: 0000

System Serial #: 00000000

Map ID: 00001

Map Name: TOF\_Tndm

Map Revision: 001.003

Map Date: 05/10/17

2

1

## PROFINET Fieldbus Screens

**NOTE:** These screens are shown only if you have a PROFINET fieldbus CGM installed.

### Screen 1

Press the  key to access this screen. Use the arrow keys to navigate to each field and the keypad to set the IP address, DHCP settings, subnet mask, gateway, and DNS information.

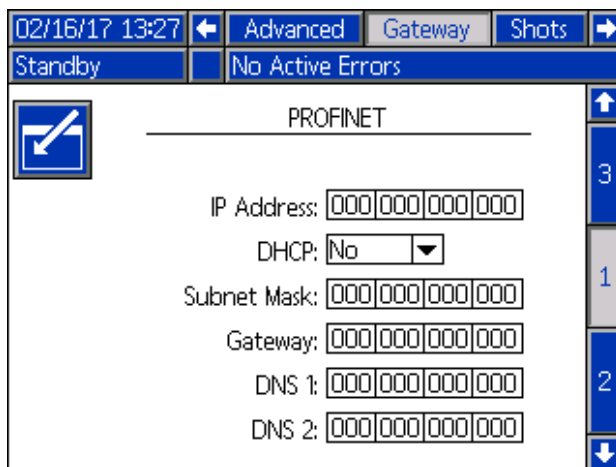

02/16/17 13:27 | Advanced | Gateway | Shots

Standby | No Active Errors

 PROFINET

IP Address:

DHCP:

Subnet Mask:

Gateway:

DNS 1:

DNS 2:

3

1

2

### Screen 2

Use the down arrow key on the ADM to navigate to screen 2. Press the  key to access this screen. You can set the station name, install date, location tag, function tag, and description.

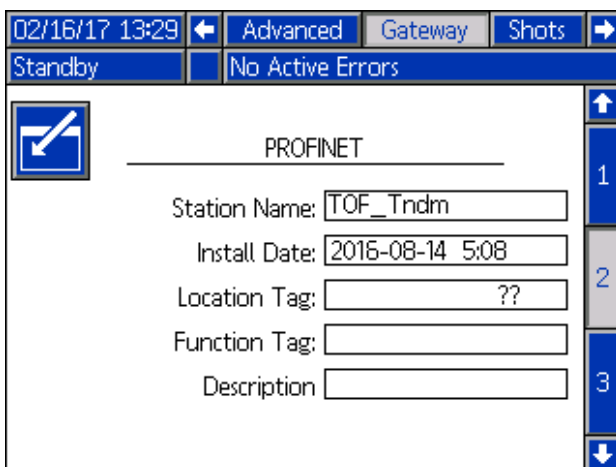

02/16/17 13:29 | Advanced | Gateway | Shots

Standby | No Active Errors

 PROFINET

Station Name:

Install Date:

Location Tag:

Function Tag:

Description:

1

2

3

### Screen 3

Use the down arrow key on the ADM to navigate to screen 3. This screen displays the hardware revision, system serial number, and data map identification information.

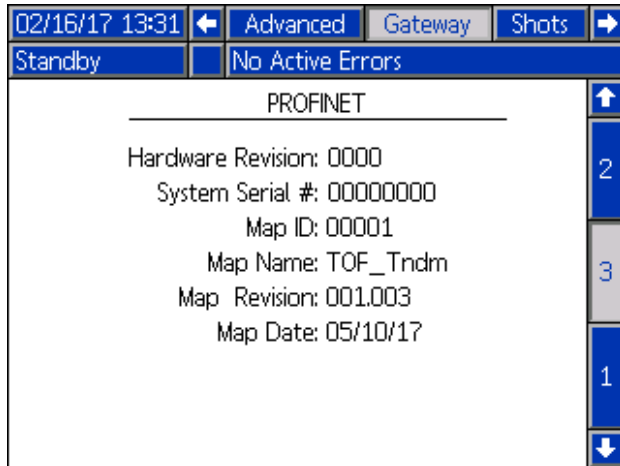

# Maintenance

## Software Update Procedure

When software is updated on the ADM, the software is then automatically updated on the CGM and all other connected Graco Control Architecture components.

1. At the ADM, turn the power switch to Off.
2. Remove the ADM from the bracket.
3. Use a hex key to remove the token access panel.

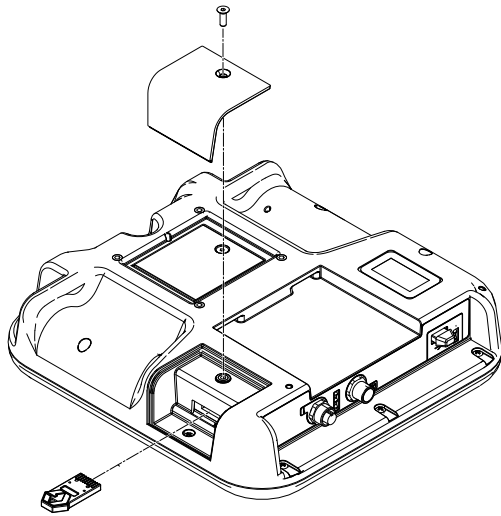

**FIG. 6: Token Location**

4. Insert and press the software upgrade token firmly into the slot.
5. Turn the power switch to On.

### **NOTICE**

A status is shown while software is updating to indicate progress. To prevent corrupting the software load, do not remove the token until the status screen disappears.

6. The Graco Splash screen is displayed until communication with other modules is established.



7. Wait for the update to complete. An approximate time to completion displays below the progress bar.
8. When the update is completed successfully, press the  key.
9. Remove the token and replace the token access panel.

**NOTE:** The software version history for each system can be viewed in the technical support section at [www.graco.com](http://www.graco.com).

## Available Internal Data

See **Appendix A - I/O Signal Descriptions** on page 13 for additional details regarding each input/output. Unless stated otherwise:

- Values are subject to the same maximum and minimum restrictions of the ADM.
- Some of the temperature data may have slight rounding errors compared to temperatures displayed on the ADM.
- On some controlling devices, the byte order may need to be reversed (byte order within instance, least significant -> most significant).

### Automation Inputs (Signals from the Therm-O-Flow to the PLC)

Instance Number	Input Byte Index(es)	Description	Units
1	0 - 1	Pump Actual Temperature, Primary	°C/°F❖
2	2 - 3	Platen Actual Temperature, Primary	°C/°F❖
3	4 - 5	Zone #1 Actual Temperature, Primary	°C/°F❖
4	6 - 7	Zone #2 Actual Temperature, Primary	°C/°F❖
5	8 - 9	Zone #3 Actual Temperature, Primary	°C/°F❖
6	10 - 11	Zone #4 Actual Temperature, Primary	°C/°F❖
7	12 - 13	Zone #5 Actual Temperature, Primary	°C/°F❖
8	14 - 15	Zone #6 Actual Temperature, Primary	°C/°F❖
9	16 - 17	Zone #7 Actual Temperature, Primary	°C/°F❖
10	18 - 19	Zone #8 Actual Temperature, Primary	°C/°F❖
11	20 - 21	Zone #9 Actual Temperature, Primary	°C/°F❖
12	22 - 23	Zone #10 Actual Temperature, Primary	°C/°F❖
13	24 - 25	Zone #11 Actual Temperature, Primary	°C/°F❖
14	26 - 27	Zone #12 Actual Temperature, Primary	°C/°F❖
15	28 - 29	Pump Setpoint Temperature Indication, Primary/Secondary	°C/°F❖
16	30 - 31	Platen Setpoint Temperature Indication, Primary/Secondary	°C/°F❖
17	32 - 33	Zone #1 Setpoint Temperature Indication, Primary/Secondary	°C/°F❖
18	34 - 35	Zone #2 Setpoint Temperature Indication, Primary/Secondary	°C/°F❖
19	36 - 37	Zone #3 Setpoint Temperature Indication, Primary/Secondary	°C/°F❖
20	38 - 39	Zone #4 Setpoint Temperature Indication, Primary/Secondary	°C/°F❖
21	40 - 41	Zone #5 Setpoint Temperature Indication, Primary/Secondary	°C/°F❖
22	42 - 43	Zone #6 Setpoint Temperature Indication, Primary/Secondary	°C/°F❖
23	44 - 45	Zone #7 Setpoint Temperature Indication, Primary/Secondary	°C/°F❖
24	46 - 47	Zone #8 Setpoint Temperature Indication, Primary/Secondary	°C/°F❖
25	48 - 49	Zone #9 Setpoint Temperature Indication, Primary/Secondary	°C/°F❖
26	50 - 51	Zone #10 Setpoint Temperature Indication, Primary/Secondary	°C/°F❖
27	52 - 53	Zone #11 Setpoint Temperature Indication, Primary/Secondary	°C/°F❖
28	54 - 55	Zone #12 Setpoint Temperature Indication, Primary/Secondary	°C/°F❖
29	56 - 57	Pump, Platen, Zones 1 – 3 States, Primary	◆
30	58 - 59	Zones 4 – 8 States, Primary	◆
31	60 - 61	Zones 9 – 12 States, Primary	◆
32*	62 - 63	Pump Setback Setpoint Temperature Indication, Primary/Secondary	°C/°F❖
33*	64 - 65	Platen Setback Setpoint Temperature Indication, Primary/Secondary	°C/°F❖
34*	66 - 67	Zone #1 Setback Setpoint Temperature Indication, Primary/Secondary	°C/°F❖
35*	68 - 69	Zone #2 Setback Setpoint Temperature Indication, Primary/Secondary	°C/°F❖
36*	70 - 71	Zone #3 Setback Setpoint Temperature Indication, Primary/Secondary	°C/°F❖

Instance Number	Input Byte Index(es)	Description	Units
37*	72 - 73	Zone #4 Setback Setpoint Temperature Indication, Primary/Secondary	°C/°F❖
38*	74 - 75	Zone #5 Setback Setpoint Temperature Indication, Primary/Secondary	°C/°F❖
39*	76 - 77	Zone #6 Setback Setpoint Temperature Indication, Primary/Secondary	°C/°F❖
40*	78 - 79	Zone #7 Setback Setpoint Temperature Indication, Primary/Secondary	°C/°F❖
41*	80 - 81	Zone #8 Setback Setpoint Temperature Indication, Primary/Secondary	°C/°F❖
42*	82 - 83	Zone #9 Setback Setpoint Temperature Indication, Primary/Secondary	°C/°F❖
43*	84 - 85	Zone #10 Setback Setpoint Temperature Indication, Primary/Secondary	°C/°F❖
44*	86 - 87	Zone #11 Setback Setpoint Temperature Indication, Primary/Secondary	°C/°F❖
45*	88 - 89	Zone #12 Setback Setpoint Temperature Indication, Primary/Secondary	°C/°F❖
46**	90 - 91	Pump Actual Temperature, Secondary	°C/°F❖
47**	92 - 93	Platen Actual Temperature, Secondary	°C/°F❖
48**	94 - 95	Zone #1 Actual Temperature, Secondary	°C/°F❖
49**	96 - 97	Zone #2 Actual Temperature, Secondary	°C/°F❖
50**	98 - 99	Zone #3 Actual Temperature, Secondary	°C/°F❖
51**	100 - 101	Zone #4 Actual Temperature, Secondary	°C/°F❖
52**	102 - 103	Zone #5 Actual Temperature, Secondary	°C/°F❖
53**	104 - 105	Zone #6 Actual Temperature, Secondary	°C/°F❖
54**	106 - 107	Zone #7 Actual Temperature, Secondary	°C/°F❖
55**	108 - 109	Zone #8 Actual Temperature, Secondary	°C/°F❖
56**	110 - 111	Zone #9 Actual Temperature, Secondary	°C/°F❖
57**	112 - 113	Zone #10 Actual Temperature, Secondary	°C/°F❖
58**	114 - 115	Zone #11 Actual Temperature, Secondary	°C/°F❖
59**	116 - 117	Zone #12 Actual Temperature, Secondary	°C/°F❖
60**	118 - 119	Pump, Platen, Zones 1 – 3 States, Secondary	◆
61**	120 - 121	Zones 4 – 8 States, Secondary	◆
62**	122 - 123	Zones 9 – 12 States, Secondary	◆
63**	124 - 127	Error / Event Code(s) Present	†
64**	128 - 131	Error / Event Code(s) Needing Acknowledged	†
65**	132 - 133	Status Word 1 Indication Bits	★
66**	134 - 135	Status Word 2 Indication Bits	★
67**	136 - 137	Data Exchange Interface Pointer Last Serviced	⚙
68**	138 - 141	Data Exchange Interface Input Value	⚙
69**	142	System Mode/State, Primary	‡
70**	143	System Mode/State, Secondary	‡

\* Data instances (setback mode setpoint temperatures) are NOT provided for the PROFIBUS and PROFINET versions of the map since the field protocols do not support that large of a map size. For PROFIBUS or PROFINET, you should use the data exchange interface to obtain setback setpoint information.

\*\* For the PROFIBUS or PROFINET versions of the map, 14 should be subtracted from the instance number and 28 should be subtracted for the input byte count so that the PROFIBUS and PROFINET versions have 56 input instances containing 116 input bytes total.

◆ Zone states are packed in groups of three bits, where each zone state equates to the following. Each zone is packed from bit 0, bit 3, bit 6, bit 9, and bit 12 corresponding to the order presented in the description. 000 - zone is not installed, 001 - zone is off, 010 - zone is in warm up state, 011 - zone is in heat soak state, 100 - zone at temperature, 101 - zone in setback mode.

❖ Temperature units match units of the ADM. Values are in tenths of a degree (for example, a value of 4005 corresponds to 400.5 °F). Setpoint temperatures are either for the primary or secondary unit, depending on the system selected by the PLC in the System Control Word.

† See **Appendix C - Error/Event Tables** on page 22.



★ See the **Status Indication Bit Tables** on page 13.

⚙ See **Appendix B - Data Exchange Interface** on page 17.

‡ System Mode/State: 0 = System Off, 1 = Inactive, 2 = Warm Up, 3 = Heat Soak, 4 = Ready (at temperature, heat soak done, pump off), 5 = Active (at ready and pump ON), 6 = Setback Mode.

## Automation Outputs (Signals from the PLC to the Therm-O-Flow)

Instance Number	Output Bytes	Description	Units
1	0	System Activate/Stop	*
2	1	Setpoint Zone Designation	**
3	2 - 3	Setpoint Temperature for Selected Zone	°C/°F**
4	4 - 5	System Control Bits	◆
5	6 - 9	Error/Event Number Acknowledged	†
6	10 - 11	Data Exchange Interface Pointer Output Designation	✿
7	12 - 15	Data Exchange Interface Output Value	✿

\* Set this byte to one of the following: 0 = Do Nothing, 1 = Turns ON the System (same as pressing the  key), 2-255 = Shuts Down the System (same as pressing the  key).

\*\* Used to set the temperature setpoints to tenths of a degree (for example, 3005 = 300.5) in the selected units of measurement (°C or °F). See the **Temperature Setpoint Zone Designation Table** on page 16.

◆ See **System Control Bits** on page 14.

† See the **Appendix C - Error/Event Tables** on page 22

✿ See **Appendix B - Data Exchange Interface** on page 17.

# Parts

## Kit No. 25C994

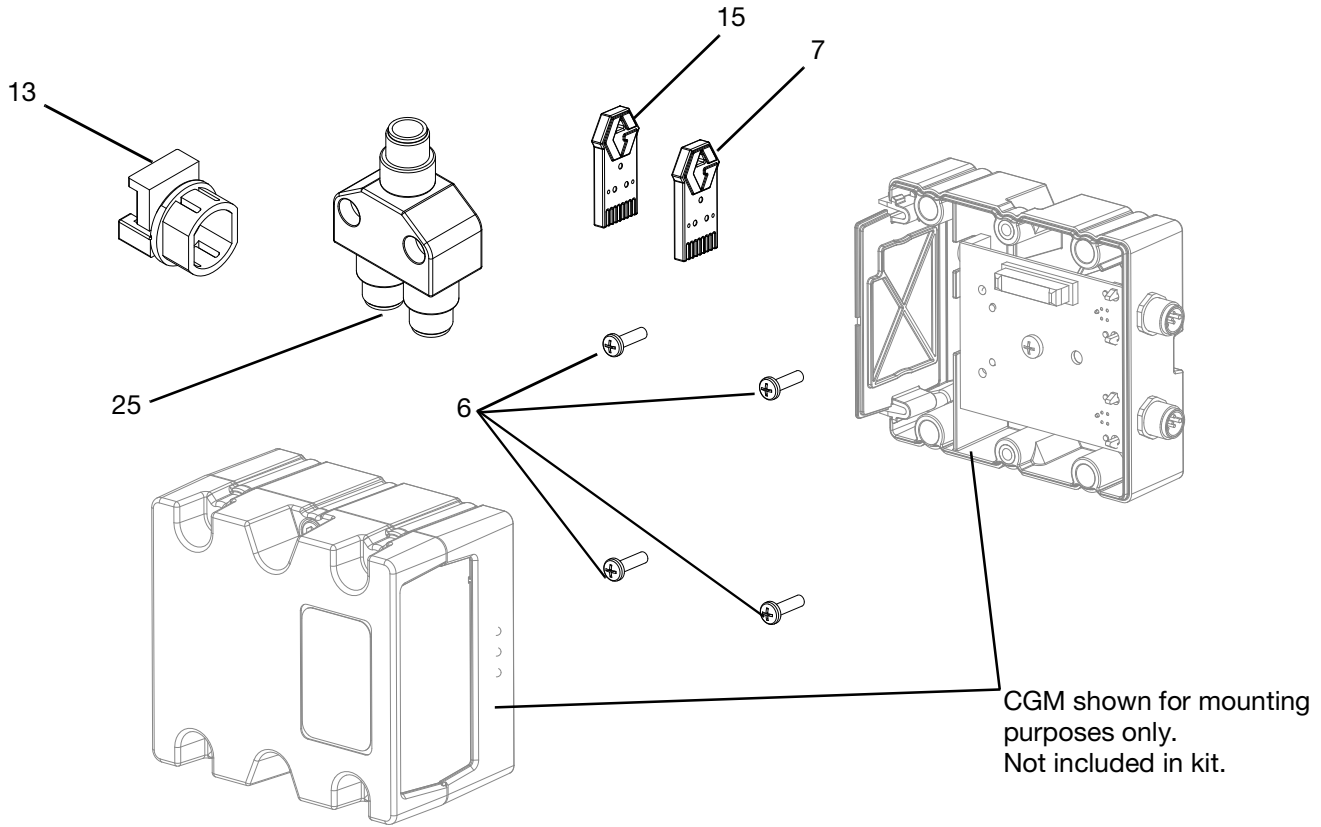

**FIG. 7: Kit 25C994 Parts**

Ref.	Part	Description	Qty.
6	96/0650/99	SCREW, tapping, phillips pan hd	4
7	17T051	TOKEN, gca, map, tof cgm	1
9	17T053+	SOFTWARE, gateway, tof, gsd	1
10	17T054+	SOFTWARE, gateway, tof, eds	1
11	17T055+	SOFTWARE, gateway, tof, gsdml	1
13	121901	SUPPRESSOR, box snap, ferrite	2
15	16H821	TOKEN, gca, upgrade, adm32	1
19	17T056+	KIT, sample program	1
20	121002+	CABLE, can, female/female 1.5 m	1
21	84/0805/89+	CABLE, TIE MOUNT, 1 x 1 sq w/adhesive	1
25	124654	CONNECTOR, splitter, (2) M12 (M) x M12 (F)	

+ Not shown.

**NOTE:** The CGM is not included in the kit. See **Models** on page 2 for available CGM modules.

## Appendix A - I/O Signal Descriptions

This section provides details about the CGM automation input and output signals.

### Heat Zone States

The signal is 0 on power up. The following values of this signal correspond to the various heat zone states. Each zone is bit packed into 3 bits for each zone designation in input instances 29-31 and 60-62 of the map.

Number	Binary #	Heat Zone State
0	000	Zone Not Installed
1	001	OFF
2	010	Warm Up
3	011	Heat Soak State
4	100	At Temperature
5	101	Setback Mode

### Status Indication Bit Tables

The following tables reflect bit-packed data, which corresponds to the status words located at input instances 65 and 66.

#### Status Word 1 Indication Bits

Bit Number	Hex Equivalent	Binary Number	Description
0	0x0001	0000 0000 0000 0001	System is ON
1	0x0002	0000 0000 0000 0010	Active System is Secondary (B) System
2	0x0004	0000 0000 0000 0100	Heat is Turned ON for Primary (A) System
3	0x0008	0000 0000 0000 1000	Heat is Turned ON for Secondary (B) System
4	0x0010	0000 0000 0001 0000	Setpoint Indications are for Secondary (B) System
5	0x0020	0000 0000 0010 0000	Setback Setpoint Indications are for Secondary (B) System
6	0x0040	0000 0000 0100 0000	Material Tracking is ON or Active
7	0x0080	0000 0000 1000 0000	Pump Priming is Active for Primary (A) System
8	0x0100	0000 0001 0000 0000	Pump Priming is Active for Secondary (B) System
9	0x0200	0000 0010 0000 0000	Pump is ON for Primary (A) System
10	0x0400	0000 0100 0000 0000	Pump is ON for Secondary (B) System
11	0x0800	0000 1000 0000 0000	Setback Mode is Active for Primary (A) System
12	0x1000	0001 0000 0000 0000	Setback Mode is Active for Secondary (B) System
13	0x2000	0010 0000 0000 0000	Data Exchange Interface is Active or in Transition
14-15	-----	-----	Reserved for Future Use





**Status Word 2 Indication Bits**

Bit Number	Hex Equivalent	Binary Number	Description
0	0x0001	0000 0000 0000 0001	Heat Soak Timer Active for Primary (A) System
1	0x0002	0000 0000 0000 0010	Heat Soak Timer Active for Secondary (B) System
2	0x0004	0000 0000 0000 0100	Turn ON Primary System (A), Heat Command Active
3	0x0008	0000 0000 0000 1000	Turn ON Secondary System (B), Heat Command Active
4	0x0010	0000 0000 0001 0000	Prime/Pump on A Command Active
5	0x0020	0000 0000 0010 0000	Prime/Pump on B Command Active
6	0x0040	0000 0000 0100 0000	Setback A Command Active
7	0x0080	0000 0000 1000 0000	Setback B Command Active
8	0x0100	0000 0001 0000 0000	Cross Over Command Active
9	0x0200	0000 0010 0000 0000	PLC Control Active Indication
10	0x0400	0000 0100 0000 0000	Heart Beat Indication for PLC from TOF (See Note 7 in <b>System Control Bits</b> )
11	0x0800	0000 1000 0000 0000	Error/Event Reported is an Alarm
12-15	-----	-----	Reserved for Future Use

**System Control Bits**

The following table reflects the bit variables in output instance 4, which can be set or cleared to control the following conditions.

Bit Number	Hex Equivalent	Binary Number	Description	Notes
0	0x0001	0000 0000 0000 0001	Turn ON Heat Command for System A Command	1
1	0x0002	0000 0000 0000 0010	Turn ON Head Command for System B Command	1
2	0x0004	0000 0000 0000 0100	Turn ON/Prime Pumps for System A Command	2
3	0x0008	0000 0000 0000 1000	Turn ON/Prime Pumps for System B Command	2
4	0x0010	0000 0000 0001 0000	Setback Command System A	3
5	0x0020	0000 0000 0010 0000	Setback Command System B	3
6	0x0040	0000 0000 0100 0000	Cross Over Command	4
7	0x0080	0000 0000 1000 0000	Pause Material Tracking/Counters Command	5
8	0x0100	0000 0001 0000 0000	Continue Material Tracking Command	5
9	0x0200	0000 0010 0000 0000	Command Setpoint Indications on Map for System B	6
10	0x0400	0000 0100 0000 0000	Command Setback Setpoint Indications for System B	6
11	0x0800	0000 1000 0000 0000	Heart Beat Output to TOF	7
12	0x1000	0001 0000 0000 0000	PLC Control Command	8
13-15	-----	-----	Reserved for Future Use	

- 1 Same as pressing  on the main Run screen.
- 2 Same as pressing  on the main Run screen.
- 3 Same as pressing  on the main Run screen.
- 4 Same as pressing  on the main Run screen.
- 5 Same as pressing  or  on the main Run screen.

- 6 *After changing the state of the command XX setpoint indications on the map for the Secondary B system bit, the controlling PLC logic should monitor the corresponding status indication bit and verify it corresponds to the command bit before monitoring the corresponding setpoint indication from the Therm-O-Flow.*
- 7 *The PLC or controlling logic needs to generate a dynamic signal at approximately a 0.333 Hz (1.5 seconds high, 1.5 seconds low) oscillation rate. The signal is present to enable detection of a communication failure between the Therm-O-Flow system and the controlling logic. The TOF system also generates the same rate dynamic signal indication (heart beat indication for PLC from TOF) signal for controlling logic to the monitor.*
- 8 *The PLC Control Command bit needs to be set, and the controlling logic needs to generate a valid heart beat output (described in note 7) to the Therm-O-Flo system before the TOF will grant the PLC requests or commands. If the heart beat output to TOF becomes a static signal (always low or high) after an extended period of time while the TOF is in PLC control, the TOF reverts to a safe state, and generates a corresponding alarm. This situation would be similar to an operator pressing the  key*

## Temperature Setpoint Zone Designation Table

The following table shows the setpoint designations in output instance 2 used to command the Therm-O-Flow temperature zones to the corresponding setpoint. Prior to writing to instance 2, the PLC needs to write the desired temperature setpoint (in tenths of a degree for the selected temperature unit of measure) to output instance 3 for the selected zone. After the zone designation has been written, the PLC can monitor the setpoint change by monitoring the correct setpoint indications: input instances 15-28 or 32-45.

Zone Designation Number	Description
0	No Zone Selected
1	Pump Setpoint Temperature, Primary
2	Platen Setpoint Temperature, Primary
3	Zone 1 Setpoint Temperature, Primary
4	Zone 2 Setpoint Temperature, Primary
5	Zone 3 Setpoint Temperature, Primary
6	Zone 4 Setpoint Temperature, Primary
7	Zone 5 Setpoint Temperature, Primary
8	Zone 6 Setpoint Temperature, Primary
9	Zone 7 Setpoint Temperature, Primary
10	Zone 8 Setpoint Temperature, Primary
11	Zone 9 Setpoint Temperature, Primary
12	Zone 10 Setpoint Temperature, Primary
13	Zone 11 Setpoint Temperature, Primary
14	Zone 12 Setpoint Temperature, Primary
15	Pump Setpoint Temperature, Secondary
16	Platen Setpoint Temperature, Secondary
17	Zone 1 Setpoint Temperature, Secondary
18	Zone 2 Setpoint Temperature, Secondary
19	Zone 3 Setpoint Temperature, Secondary
20	Zone 4 Setpoint Temperature, Secondary
21	Zone 5 Setpoint Temperature, Secondary
22	Zone 6 Setpoint Temperature, Secondary
23	Zone 7 Setpoint Temperature, Secondary
24	Zone 8 Setpoint Temperature, Secondary
25	Zone 9 Setpoint Temperature, Secondary
26	Zone 10 Setpoint Temperature, Secondary
27	Zone 11 Setpoint Temperature, Secondary
28	Zone 12 Setpoint Temperature, Secondary
61	Pump Setback Setpoint Temperature, Primary
62	Platen Setback Setpoint Temperature, Primary

63	Zone 1 Setback Setpoint Temperature, Primary
64	Zone 2 Setback Setpoint Temperature, Primary
65	Zone 3 Setback Setpoint Temperature, Primary
66	Zone 4 Setback Setpoint Temperature, Primary
67	Zone 5 Setback Setpoint Temperature, Primary
68	Zone 6 Setback Setpoint Temperature, Primary
69	Zone 7 Setback Setpoint Temperature, Primary
70	Zone 8 Setback Setpoint Temperature, Primary
71	Zone 9 Setback Setpoint Temperature, Primary
72	Zone 10 Setback Setpoint Temperature, Primary
73	Zone 11 Setback Setpoint Temperature, Primary
74	Zone 12 Setback Setpoint Temperature, Primary
75	Pump Setback Setpoint Temperature, Secondary
76	Platen Setback Setpoint Temperature, Secondary
77	Zone 1 Setback Setpoint Temperature, Secondary
78	Zone 2 Setback Setpoint Temperature, Secondary
79	Zone 3 Setback Setpoint Temperature, Secondary
80	Zone 4 Setback Setpoint Temperature, Secondary
81	Zone 5 Setback Setpoint Temperature, Secondary
82	Zone 6 Setback Setpoint Temperature, Secondary
83	Zone 7 Setback Setpoint Temperature, Secondary
84	Zone 8 Setback Setpoint Temperature, Secondary
85	Zone 9 Setback Setpoint Temperature, Secondary
86	Zone 10 Setback Setpoint Temperature, Secondary
87	Zone 11 Setback Setpoint Temperature, Secondary
88	Zone 12 Setback Setpoint Temperature, Secondary

## Appendix B - Data Exchange Interface

The Data Exchange Interface is a bi-directional interface that enables both transmitting and receiving data between the Therm-O-Flow system and the controlling logic (PLC). The interface allows a large amount of data to exchange between the systems while only occupying a very small data map to support the exchange. The interface also allows for future expansion of data without changing the map structure.

*To get or receive data from the supply system, the controlling PLC needs to:*

1. Write to the Data Exchange Interface Pointer Output Designation location on the map (output instance 6) a value corresponding to the data the PLC wants to receive.
2. Wait for the Therm-O-Flow to provide the same Pointer Designation number written in the previous step at input instance 67 (Data Exchange Interface Pointer Last Serviced).
3. Read the requested data at input instance 68, Data Exchange Interface Input Value.

*To write or transmit data to the supply system, the controlling PLC needs to:*

1. Write the data for the Therm-O-Flow system to the Data Exchange Interface Output Value location, output instance 7.
2. Write to the Data Exchange Interface Pointer Output Designation location on the map (output instance 6) a value corresponding to the data the PLC is going to transmit to the supply system.
3. The Therm-O-Flow system echoes back to the PLC the Pointer Designation and the Data Interface Value after the Therm-O-Flow system processes the data transmit request to input instances 67 and 68 respectively.



When the controlling logic is exchanging data over this interface, the Therm-O-Flow system sets the Data Exchange Interface Active or in Transition status bit while it processes the request and writes to the Data Exchange Interface input locations (input instances 67 and 68).

After valid data is present at the input instances, the Therm-O-Flow system clears the bit. While the bit is set, the controlling PLC should ignore the interface inputs until the bit is cleared. After the Therm-O-Flow system services the request, the designation pointer input matches the designation pointer output. If the scan rate of the controlling PLC or control logic is slow enough, monitoring of the status bit may not be necessary.

**NOTE:** When changes are made over the Data Exchange Interface, the Therm-O-Flow system display screen may not update immediately. It may be necessary to navigate away from the screen, then back to it.

## Data Exchange Interface Pointer Designation Table

Pointer Designation	Description	Comments	Read/Write
0	Interface Not Active		
1	Set Temperature Units	Value - Setting 0 - °F 1 - °C	Read
2	Read Temperature Units		Write
3	Set Mass Units	Value - Setting (0 - g, 1 - kg, 2 - lb)	Write
4	Read Mass Units		Read
5	Set Specific Gravity	Specific gravity in thousandths (for instance a SG setting of 1.055 = 1055).	Write
6	Read Specific Gravity		Read
7	Set High Temp. Alarm Offset	In whole selected C or F units of measure.	Write
8	Get High Temp. Alarm Offset		Read
9	Set High Temp. Deviation Offset		Write
10	Get High Temp. Deviation Offset		Read
11	Set Low Temp. Alarm Offset		Write
12	Get Low Temp. Alarm Offset		Read
13	Set Low Temp. Deviation Offset		Write
14	Get Low Temp. Deviation Offset		Read
15	Set Prime Pump Duration	Prime pump duration setting in second increments	Write
16	Get Prime Pump Duration		Read
17	Read System Version	A 32-bit string in the format of 0xXXCCBBAA. 0xCC...Build Version 0xBB...Minor Version 0xAA...Major Version	Read
18	Read System Date	A 32-bit string in the format of 0xXXDDCCBB. 0xDD...Year (0x0D corresponds to 2013) 0xCC...Month (0x0A corresponds to October) 0xBB...Day	Read
19	Read System Time	A 32-bit string in the format of 0xDDHHMMSS. 0xHH...Hours 0xMM...Minutes 0xSS...Seconds 0xDD...Day of week (0x01 corresponds to Monday)	Read
20	Read ADM Version	A 32-bit string in the format of 0xXXMMNNBB 0xMM...Major # 0xNN...Minor # 0xBB...Build #	
21 - 90	Reserved for Future Use		

Pointer Designation	Description	Comments	Read/Write
91	Read Pump A Resettable Material counter	In selected mass units, times 10. So, for instance, if in Kg mode, 101 = 10.1 Kg.	read
92	Read Pump B Resettable Material counter		read
93	Reset Pump A Resettable material counter	No Data required for Data Exchange Interface Output Value location (Same as pressing  on the corresponding setup or run screen).	Write
94	Reset Pump B Resettable material counter		Write
95	Read Pump A Resettable Cycle counter	In whole pump cycle units of measure.	read
96	Read Pump B Resettable Cycle counter		read
97	Reset Pump A Resettable Cycle counter	No Data required for Data Exchange Interface Output Value location (Same as pressing  on the corresponding setup or run screen).	Write
98	Reset Pump B Resettable Cycle counter		Write
99-100	Reserved for Future Use		
101	Get Heat Soak Timer A	Get Primary or Secondary Heat Soak timer Remaining Count in Seconds (= 0 if not active)	Read
102	Get Heat Soak Timer B		Read
103 - 110	Reserved for Future Use		
111	Get CV Percent (5051 = 50.51%)	Get Control Variable for Pump, Primary Heat Zone	Read
112	Get CV Percent (5051 = 50.51%)	Get Control Variable for Platen, Primary Heat Zone	Read
113	Get CV Percent (5051 = 50.51%)	Get Control Variable for Heat Zone 1, Primary	Read
114	Get CV Percent (5051 = 50.51%)	Get Control Variable for Heat Zone 2, Primary	Read
115	Get CV Percent (5051 = 50.51%)	Get Control Variable for Heat Zone 3, Primary	Read
116	Get CV Percent (5051 = 50.51%)	Get Control Variable for Heat Zone 4, Primary	Read
117	Get CV Percent (5051 = 50.51%)	Get Control Variable for Heat Zone 5, Primary	Read
118	Get CV Percent (5051 = 50.51%)	Get Control Variable for Heat Zone 6, Primary	Read
119	Get CV Percent (5051 = 50.51%)	Get Control Variable for Heat Zone 7, Primary	Read
120	Get CV Percent (5051 = 50.51%)	Get Control Variable for Heat Zone 8, Primary	Read
121	Get CV Percent (5051 = 50.51%)	Get Control Variable for Heat Zone 9, Primary	Read
122	Get CV Percent (5051 = 50.51%)	Get Control Variable for Heat Zone 10, Primary	Read
123	Get CV Percent (5051 = 50.51%)	Get Control Variable for Heat Zone 11, Primary	Read
124	Get CV Percent (5051 = 50.51%)	Get Control Variable for Heat Zone 12, Primary	Read

Pointer Designation	Description	Comments	Read/Write
125	Get CV Percent (5051 = 50.51%)	Get Control Variable for Pump, Secondary Heat Zone	Read
126	Get CV Percent (5051 = 50.51%)	Get Control Variable for Platen, Secondary Heat Zone	Read
127	Get CV Percent (5051 = 50.51%)	Get Control Variable for Heat Zone 1, Secondary	Read
128	Get CV Percent (5051 = 50.51%)	Get Control Variable for Heat Zone 2, Secondary	Read
129	Get CV Percent (5051 = 50.51%)	Get Control Variable for Heat Zone 3, Secondary	Read
130	Get CV Percent (5051 = 50.51%)	Get Control Variable for Heat Zone 4, Secondary	Read
131	Get CV Percent (5051 = 50.51%)	Get Control Variable for Heat Zone 5, Secondary	Read
132	Get CV Percent (5051 = 50.51%)	Get Control Variable for Heat Zone 6, Secondary	Read
133	Get CV Percent (5051 = 50.51%)	Get Control Variable for Heat Zone 7, Secondary	Read
134	Get CV Percent (5051 = 50.51%)	Get Control Variable for Heat Zone 8, Secondary	Read
135	Get CV Percent (5051 = 50.51%)	Get Control Variable for Heat Zone 9, Secondary	Read
136	Get CV Percent (5051 = 50.51%)	Get Control Variable for Heat Zone 10, Secondary	Read
137	Get CV Percent (5051 = 50.51%)	Get Control Variable for Heat Zone 11, Secondary	Read
138	Get CV Percent (5051 = 50.51%)	Get Control Variable for Heat Zone 12, Secondary	Read
139 - 150	Reserved for Future Use		
151	Get Pump A Setback Setpoint Temperature	Provides the selected Primary System Zone Setback Mode setpoint temperature setting to the interface. Temperature Units match units of the ADM. Values are in tenths of a degree (for example, a value of 2505 corresponds to 250.5°F). These pointer designations are typically used for PROFIBUS and PROFINET applications.	Read
152	Get Platen A Setback Setpoint Temperature		Read
153	Get Zone 1, A Setback Setpoint Temperature		Read
154	Get Zone 2, A Setback Setpoint Temperature		Read
155	Get Zone 3, A Setback Setpoint Temperature		Read
156	Get Zone 4, A Setback Setpoint Temperature		Read
157	Get Zone 5, A Setback Setpoint Temperature		Read
158	Get Zone 6, A Setback Setpoint Temperature		Read
159	Get Zone 7, A Setback Setpoint Temperature		Read
160	Get Zone 8, A Setback Setpoint Temperature		Read
161	Get Zone 9, A Setback Setpoint Temperature		Read
162	Get Zone 10, A Setback Setpoint Temperature		Read
163	Get Zone 11, A Setback Setpoint Temperature		Read
164	Get Zone 12, A Setback Setpoint Temperature		Read

Pointer Designation	Description	Comments	Read/Write
165	Get Pump B Setback Setpoint Temperature	Provides the selected Secondary System Zone Setback Mode setpoint temperature setting to the interface. Temperature Units match units of the ADM. Values are in tenths of a degree (for example, a value of 2505 corresponds to 250.5°F). These pointer designations are typically used for PROFIBUS and PROFINET applications.	Read
166	Get Platen B Setback Setpoint Temperature		Read
167	Get Zone 1, B Sec. Setback Setpoint Temperature		Read
168	Get Zone 2, B Setback Setpoint Temperature		Read
169	Get Zone 3, B Setback Setpoint Temperature		Read
170	Get Zone 4, B Setback Setpoint Temperature		Read
171	Get Zone 5, B Setback Setpoint Temperature		Read
172	Get Zone 6, B Setback Setpoint Temperature		Read
173	Get Zone 7, B Setback Setpoint Temperature		Read
174	Get Zone 8, B Setback Setpoint Temperature		Read
175	Get Zone 9, B Setback Setpoint Temperature		Read
176	Get Zone 10, B Setback Setpoint Temperature		Read
177	Get Zone 11, B Setback Setpoint Temperature		Read
178	Get Zone 12, B Setback Setpoint Temperature	Read	
179 - ~65k	Reserved for Future Use		

## Appendix C - Error/Event Tables

The following table reflects codes provided in input instances 63 and 64 and output instance 5. To acknowledge an error, when the PLC notices a non-zero error code in instance 64, the PLC logic needs to write the same code to output instance 5 to remove the error message pop-up window from the ADM display. After the event or error is acknowledged by the PLC, the pop-up window disappears and the error code is cleared from instance 64. If the condition is no longer present, the error code is removed from instance 63. If multiple conditions exist, the process may need to be repeated for each condition.

The error codes described and presented on input 63 and 64 are the four digit codes presented below in ASCII format packed into a 32-bit double word. Each character of the code occupies a byte within the 32-bit double word, read right to left.

Error/Event Code	Description
0	No Active Error
A1A1	Low Current Unit A Zone 1
A1A2	Low Current Unit A Zone 2
A1A3	Low Current Unit A Zone 3
A1A4	Low Current Unit A Zone 4
A1A5	Low Current Unit A Zone 5
A1A6	Low Current Unit A Zone 6
A1A7	Low Current Unit A Zone 7
A1A8	Low Current Unit A Zone 8
A1A9	Low Current Unit A Zone 9
A1AA	Low Current Unit A Zone 10
A1AB	Low Current Unit A Zone 11
A1AC	Low Current Unit A Zone 12
A1AD	Low Current Unit A Pump
A1AE	Low Current Unit A Platen
A1B1	Low Current Unit B Zone 1
A1B2	Low Current Unit B Zone 2
A1B3	Low Current Unit B Zone 3
A1B4	Low Current Unit B Zone 4
A1B5	Low Current Unit B Zone 5
A1B6	Low Current Unit B Zone 6
A1B7	Low Current Unit B Zone 7
A1B8	Low Current Unit B Zone 8
A1B9	Low Current Unit B Zone 9

A1BA	Low Current Unit B Zone 10
A1BB	Low Current Unit B Zone 11
A1BC	Low Current Unit B Zone 12
A1BD	Low Current Unit B Pump
A1BE	Low Current Unit B Platen
A1C1	Low Current Fan MZLP 1
A1C2	Low Current Fan MZLP 2
A1C3	Low Current Fan MZLP 3
A1C4	Low Current Fan MZLP 4
A1C5	Low Current Fan MZLP 5
A1C6	Low Current Fan MZLP 6
A1C7	Low Current Fan MZLP 7
A1CG	Low Current Fan Gateway
A1CV	Low Current Fan AWB, Unit A
A1CW	Low Current Fan AWB, Unit B
A1CX	Low Current Fan System I/O, Unit A
A1CY	Low Current Fan System I/O, Unit B
A2A1	Low Current Unit A Zone 1
A2A2	Low Current Unit A Zone 2
A2A3	Low Current Unit A Zone 3
A2A4	Low Current Unit A Zone 4
A2A5	Low Current Unit A Zone 5
A2A6	Low Current Unit A Zone 6
A2A7	Low Current Unit A Zone 7
A2A8	Low Current Unit A Zone 8
A2A9	Low Current Unit A Zone 9
A2AA	Low Current Unit A Zone 10
A2AB	Low Current Unit A Zone 11
A2AC	Low Current Unit A Zone 12
A2AD	Low Current Unit A Pump
A2AE	Low Current Unit A Platen
A2B1	Low Current Unit B Zone 1
A2B2	Low Current Unit B Zone 2
A2B3	Low Current Unit B Zone 3
A2B4	Low Current Unit B Zone 4
A2B5	Low Current Unit B Zone 5
A2B6	Low Current Unit B Zone 6
A2B7	Low Current Unit B Zone 7
A2B8	Low Current Unit B Zone 8
A2B9	Low Current Unit B Zone 9
A2BA	Low Current Unit B Zone 10

<b>Error/Event Code</b>	<b>Description</b>
A2BB	Low Current Unit B Zone 11
A2BC	Low Current Unit B Zone 12
A2BD	Low Current Unit B Pump
A2BE	Low Current Unit B Platen
A2C1	Low Current Fan MZLP 1
A2C2	Low Current Fan MZLP 2
A2C3	Low Current Fan MZLP 3
A2C4	Low Current Fan MZLP 4
A2C5	Low Current Fan MZLP 5
A2C6	Low Current Fan MZLP 6
A2C7	Low Current Fan MZLP 7
A2CG	Low Current Fan Gateway
A2CV	Low Current Fan AWB, Unit A
A2CW	Low Current Fan AWB, Unit B
A2CX	Low Current Fan System I/O, Unit A
A2CY	Low Current Fan System I/O, Unit B
A3A1	High Current Unit A Zone 1
A3A2	High Current Unit A Zone 2
A3A3	High Current Unit A Zone 3
A3A4	High Current Unit A Zone 4
A3A5	High Current Unit A Zone 5
A3A6	High Current Unit A Zone 6
A3A7	High Current Unit A Zone 7
A3A8	High Current Unit A Zone 8
A3A9	High Current Unit A Zone 9
A3AA	High Current Unit A Zone 10
A3AB	High Current Unit A Zone 11
A3AC	High Current Unit A Zone 12
A3AD	High Current Unit A Pump
A3AE	High Current Unit A Platen
A3B1	High Current Unit B Zone 1
A3B2	High Current Unit B Zone 2
A3B3	High Current Unit B Zone 3
A3B4	High Current Unit B Zone 4
A3B5	High Current Unit B Zone 5
A3B6	High Current Unit B Zone 6
A3B7	High Current Unit B Zone 7
A3B8	High Current Unit B Zone 8
A3B9	High Current Unit B Zone 9
A3BA	High Current Unit B Zone 10
A3BB	High Current Unit B Zone 11

A3BC	High Current Unit B Zone 12
A3BD	High Current Unit B Pump
A3BE	High Current Unit B Platen
A3C1	High Current Fan MZLP 1
A3C2	High Current Fan MZLP 2
A3C3	High Current Fan MZLP 3
A3C4	High Current Fan MZLP 4
A3C5	High Current Fan MZLP 5
A3C6	High Current Fan MZLP 6
A3C7	High Current Fan MZLP 7
A3CG	High Current Fan Gateway
A3CV	High Current Fan AWB, Unit A
A3CW	High Current Fan AWB, Unit B
A3CX	High Current Fan System I/O, Unit A
A3CY	High Current Fan System I/O, Unit B
A4A1	High Current Unit A Zone 1
A4A2	High Current Unit A Zone 2
A4A3	High Current Unit A Zone 3
A4A4	High Current Unit A Zone 4
A4A5	High Current Unit A Zone 5
A4A6	High Current Unit A Zone 6
A4A7	High Current Unit A Zone 7
A4A8	High Current Unit A Zone 8
A4A9	High Current Unit A Zone 9
A4AA	High Current Unit A Zone 10
A4AB	High Current Unit A Zone 11
A4AC	High Current Unit A Zone 12
A4AD	High Current Unit A Pump
A4AE	High Current Unit A Platen
A4B1	High Current Unit B Zone 1
A4B2	High Current Unit B Zone 2
A4B3	High Current Unit B Zone 3
A4B4	High Current Unit B Zone 4
A4B5	High Current Unit B Zone 5
A4B6	High Current Unit B Zone 6
A4B7	High Current Unit B Zone 7
A4B8	High Current Unit B Zone 8
A4B9	High Current Unit B Zone 9
A4BA	High Current Unit B Zone 10
A4BB	High Current Unit B Zone 11
A4BC	High Current Unit B Zone 12
A4BD	High Current Unit B Pump
A4BE	High Current Unit B Platen

Appendix C - Error/Event Tables

<b>Error/Event Code</b>	<b>Description</b>
A4C1	High Current Fan MZLP 1
A4C2	High Current Fan MZLP 2
A4C3	High Current Fan MZLP 3
A4C4	High Current Fan MZLP 4
A4C5	High Current Fan MZLP 5
A4C6	High Current Fan MZLP 6
A4C7	High Current Fan MZLP 7
A4CG	High Current Fan Gateway
A4CV	High Current Fan AWB, Unit A
A4CW	High Current Fan AWB, Unit B
A4CX	High Current Fan System I/O, Unit A
A4CY	High Current Fan System I/O, Unit B
A7A1	Unexp. Curr. Unit A Zone 1
A7A2	Unexp. Curr. Unit A Zone 2
A7A3	Unexp. Curr. Unit A Zone 3
A7A4	Unexp. Curr. Unit A Zone 4
A7A5	Unexp. Curr. Unit A Zone 5
A7A6	Unexp. Curr. Unit A Zone 6
A7A7	Unexp. Curr. Unit A Zone 7
A7A8	Unexp. Curr. Unit A Zone 8
A7A9	Unexp. Curr. Unit A Zone 9
A7AA	Unexp. Curr. Unit A Zone 10
A7AB	Unexp. Curr. Unit A Zone 11
A7AC	Unexp. Curr. Unit A Zone 12
A7AD	Unexp. Curr. Unit A Pump
A7AE	Unexp. Curr. Unit A Platen
A7B1	Unexp. Curr. Unit B Zone 1
A7B2	Unexp. Curr. Unit B Zone 2
A7B3	Unexp. Curr. Unit B Zone 3
A7B4	Unexp. Curr. Unit B Zone 4
A7B5	Unexp. Curr. Unit B Zone 5
A7B6	Unexp. Curr. Unit B Zone 6
A7B7	Unexp. Curr. Unit B Zone 7
A7B8	Unexp. Curr. Unit B Zone 8
A7B9	Unexp. Curr. Unit B Zone 9
A7BA	Unexp. Curr. Unit B Zone 10
A7BB	Unexp. Curr. Unit B Zone 11
A7BC	Unexp. Curr. Unit B Zone 12
A7BD	Unexp. Curr. Unit B Pump
A7BE	Unexp. Curr. Unit B Platen
A7C1	Unexp. Curr. Fan MZLP 1

A7C2	Unexp. Curr. Fan MZLP 2
A7C3	Unexp. Curr. Fan MZLP 3
A7C4	Unexp. Curr. Fan MZLP 4
A7C5	Unexp. Curr. Fan MZLP 5
A7C6	Unexp. Curr. Fan MZLP 6
A7C7	Unexp. Curr. Fan MZLP 7
A7CG	Unexp. Curr. Fan Gateway
A7CV	Unexp. Curr. Fan AWB, Unit A
A7CW	Unexp. Curr. Fan AWB, Unit B
A7CX	Unexp. Curr. Fan System I/O, Unit A
A7CY	Unexp. Curr. Fan System I/O, Unit B
A8A1	No Current Unit A Zone 1
A8A2	No Current Unit A Zone 2
A8A3	No Current Unit A Zone 3
A8A4	No Current Unit A Zone 4
A8A5	No Current Unit A Zone 5
A8A6	No Current Unit A Zone 6
A8A7	No Current Unit A Zone 7
A8A8	No Current Unit A Zone 8
A8A9	No Current Unit A Zone 9
A8AA	No Current Unit A Zone 10
A8AB	No Current Unit A Zone 11
A8AC	No Current Unit A Zone 12
A8AD	No Current Unit A Pump
A8AE	No Current Unit A Platen
A8B1	No Current Unit B Zone 1
A8B2	No Current Unit B Zone 2
A8B3	No Current Unit B Zone 3
A8B4	No Current Unit B Zone 4
A8B5	No Current Unit B Zone 5
A8B6	No Current Unit B Zone 6
A8B7	No Current Unit B Zone 7
A8B8	No Current Unit B Zone 8
A8B9	No Current Unit B Zone 9
A8BA	No Current Unit B Zone 10
A8BB	No Current Unit B Zone 11
A8BC	No Current Unit B Zone 12
A8BD	No Current Unit B Pump
A8BE	No Current Unit B Platen
A8C1	No Current Fan MZLP 1
A8C2	No Current Fan MZLP 2
A8C3	No Current Fan MZLP 3
A8C4	No Current Fan MZLP 4

<b>Error/Event Code</b>	<b>Description</b>
A8C5	No Current Fan MZLP 5
A8C6	No Current Fan MZLP 6
A8C7	No Current Fan MZLP 7
A8CG	No Current Fan Gateway
A8CV	No Current Fan AWB, Unit A
A8CW	No Current Fan AWB, Unit B
A8CX	No Current Fan System I/O, Unit A
A8CY	No Current Fan System I/O, Unit B
AAMA	No Current Fan Unit A
AAMB	No Current Fan Unit B
AM31	High Current SSR MZLP 1
AM32	High Current SSR MZLP 2
AM33	High Current SSR MZLP 3
AM34	High Current SSR MZLP 4
AM35	High Current SSR MZLP 5
AM36	High Current SSR MZLP 6
AM37	High Current SSR MZLP 7
AM3G	High Current SSR Gateway
AM3V	High Current SSR AWB, Unit A
AM3W	High Current SSR AWB, Unit B
AM3X	High Current SSR System I/O, Unit A
AM3Y	High Current SSR System I/O, Unit B
AM41	High Current Contactor MZLP 1
AM42	High Current Contactor MZLP 2
AM43	High Current Contactor MZLP 3
AM44	High Current Contactor MZLP 4
AM45	High Current Contactor MZLP 5
AM46	High Current Contactor MZLP 6
AM47	High Current Contactor MZLP 7
AM4G	High Current Contactor Gateway
AM4V	High Current Contactor AWB, Unit A
AM4W	High Current Contactor AWB, Unit B
AM4X	High Current Contactor System I/O, Unit A
AM4Y	High Current Contactor System I/O, Unit B
AM71	Unexp. Curr. Contactor MZLP 1
AM72	Unexp. Curr. Contactor MZLP 2
AM73	Unexp. Curr. Contactor MZLP 3
AM74	Unexp. Curr. Contactor MZLP 4
AM75	Unexp. Curr. Contactor MZLP 5
AM76	Unexp. Curr. Contactor MZLP 6

AM77	Unexp. Curr. Contactor MZLP 7
AM7G	Unexp. Curr. Contactor Gateway
AM7V	Unexp. Curr. Contactor AWB, Unit A
AM7W	Unexp. Curr. Contactor AWB, Unit B
AM7X	Unexp. Curr. Contactor System I/O, Unit A
AM7Y	Unexp. Curr. Contactor System I/O, Unit B
AM81	No Current Contactor MZLP 1
AM82	No Current Contactor MZLP 2
AM83	No Current Contactor MZLP 3
AM84	No Current Contactor MZLP 4
AM85	No Current Contactor MZLP 5
AM86	No Current Contactor MZLP 6
AM87	No Current Contactor MZLP 7
AM8G	No Current Contactor Gateway
AM8V	No Current Contactor AWB, Unit A
AM8W	No Current Contactor AWB, Unit B
AM8X	No Current Contactor System I/O, Unit A
AM8Y	No Current Contactor System I/O, Unit B
CAC1	Comm. Error MZLP 1
CAC2	Comm. Error MZLP 2
CAC3	Comm. Error MZLP 3
CAC4	Comm. Error MZLP 4
CAC5	Comm. Error MZLP 5
CAC6	Comm. Error MZLP 6
CAC7	Comm. Error MZLP 7
CACG	Comm. Error Gateway
CACH	Gateway Heart Beat Lost
CACV	Comm. Error AWB, Unit A
CACW	Comm. Error AWB, Unit B
CACX	Comm. Error System I/O, Unit A
CACY	Comm. Error System I/O, Unit B
DAAX	Pump Runaway Unit A
DABX	Pump Runaway Unit B
DCAX	Pump Diving Unit A
DCBX	Pump Diving Unit B
DEAX	Cycle Switch Err. Unit A
DEBX	Cycle Switch Err. Unit B
EAAA	Heat On Unit A
EAAB	Heat On Unit B
EACA	Mat. Counter Paused Unit A
EACB	Mat. Counter Paused Unit B
EAPA	Pump On Unit A

<b>Error/Event Code</b>	<b>Description</b>
EAPB	Pump On Unit B
EAUX	USB Activity In Process
EB0X	Stop Button Pressed
EBAA	Heat Off Unit A
EBAB	Heat Off Unit B
EBCA	Mat. Counter Unpaused Unit A
EBCB	Mat. Counter Unpaused Unit B
EBPA	Pump Off Unit A
EBPB	Pump Off Unit B
EBUX	USB Drive Removed
EBRX	Red Key locked out PLC
EC0X	Setup Value(s) Changed
ECA1	Unit A Zone 1
ECA2	Unit A Zone 2
ECA3	Unit A Zone 3
ECA4	Unit A Zone 4
ECA5	Unit A Zone 5
ECA6	Unit A Zone 6
ECA7	Unit A Zone 7
ECA8	Unit A Zone 8
ECA9	Unit A Zone 9
ECAA	Unit A Zone 10
ECAB	Unit A Zone 11
ECAC	Unit A Zone 12
ECAD	Unit A Pump
ECAE	Unit A Platen
ECB1	Unit B Zone 1
ECB2	Unit B Zone 2
ECB3	Unit B Zone 3
ECB4	Unit B Zone 4
ECB5	Unit B Zone 5
ECB6	Unit B Zone 6
ECB7	Unit B Zone 7
ECB8	Unit B Zone 8
ECB9	Unit B Zone 9
ECBA	Unit B Zone 10
ECBB	Unit B Zone 11
ECBC	Unit B Zone 12
ECBD	Unit B Pump
ECBE	Unit B Platen
ECMA	Maintenance Counter Changed Unit A

ECMB	Maintenance Counter Changed Unit B
EHCA	Heat Soak Complete Unit A
EHCB	Heat Soak Complete Unit B
EHHA	Heat Soak Started Unit A
EHHB	Heat Soak Started Unit B
EHPA	Pump Inactive Timeout Unit A
EHPB	Pump Inactive Timeout Unit B
EHSA	Setback Unit A
EHSB	Setback Unit B
EHTA	At Temp Unit A
EHTB	At Temp Unit B
EHWA	Warmup Unit A
EHWB	Warmup Unit B
EKAA	Auto-Crossover To A
EKAB	Auto-Crossover To B
EKMA	Manual-Crossover To A
EKMB	Manual-Crossover To B
EL0X	System Power On
EM0X	System Power Off
EP0X	Blue Token Detected
EQU1	Sys. Settings Downloaded
EQU2	Sys. Settings Uploaded
EQU3	Custom Lang. Downloaded
EQU4	Custom Lang. Uploaded
EQU5	Logs Downloaded
ERCA	Pump Cycles Tot. Reset Unit A
ERCB	Pump Cycles Tot. Reset Unit B
ERMA	User Maint. Count Reset Unit A
ERMB	User Maint. Count Reset Unit B
ERWA	Pump Weight Tot. Reset Unit A
ERWB	Pump Weight Tot. Reset Unit B
ETAA	Timer Event On Unit A
ETAB	Timer Event On Unit B
ETBA	Timer Event Off Unit A
ETBB	Timer Event Off Unit B
ETSA	Timer Event Setback Unit A
ETSB	Timer Event Setback Unit B
EVUX	USB Disabled
L1AX	Level Sensor Error Unit A
L1BX	Level Sensor Error Unit B
L2AX	Drum Empty Unit A
L2BX	Drum Empty Unit B
L3AX	Drum Low Unit A

<b>Error/Event Code</b>	<b>Description</b>
L3BX	Drum Low Unit B
M8MA	Clean/Check Fan Unit A
M8MB	Clean/Check Fan Unit B
MMUX	USB Logs Full
MNAX	Maintenance Due - User Unit A
MNBX	Maintenance Due - User Unit B
T1A1	Low Temp. Unit A Zone 1
T1A2	Low Temp. Unit A Zone 2
T1A3	Low Temp. Unit A Zone 3
T1A4	Low Temp. Unit A Zone 4
T1A5	Low Temp. Unit A Zone 5
T1A6	Low Temp. Unit A Zone 6
T1A7	Low Temp. Unit A Zone 7
T1A8	Low Temp. Unit A Zone 8
T1A9	Low Temp. Unit A Zone 9
T1AA	Low Temp. Unit A Zone 10
T1AB	Low Temp. Unit A Zone 11
T1AC	Low Temp. Unit A Zone 12
T1AD	Low Temp. Unit A Pump
T1AE	Low Temp. Unit A Platen
T1B1	Low Temp. Unit B Zone 1
T1B2	Low Temp. Unit B Zone 2
T1B3	Low Temp. Unit B Zone 3
T1B4	Low Temp. Unit B Zone 4
T1B5	Low Temp. Unit B Zone 5
T1B6	Low Temp. Unit B Zone 6
T1B7	Low Temp. Unit B Zone 7
T1B8	Low Temp. Unit B Zone 8
T1B9	Low Temp. Unit B Zone 9
T1BA	Low Temp. Unit B Zone 10
T1BB	Low Temp. Unit B Zone 11
T1BC	Low Temp. Unit B Zone 12
T1BD	Low Temp. Unit B Pump
T1BE	Low Temp. Unit B Platen
T1C1	Low Temp. MZLP 1
T1C2	Low Temp. MZLP 2
T1C3	Low Temp. MZLP 3
T1C4	Low Temp. MZLP 4
T1C5	Low Temp. MZLP 5
T1C6	Low Temp. MZLP 6
T1C7	Low Temp. MZLP 7

T1CG	Low Temp. Gateway
T1CV	Low Temp. AWB, Unit A
T1CW	Low Temp. AWB, Unit B
T1CX	Low Temp. System I/O, Unit A
T1CY	Low Temp. System I/O, Unit B
T2A1	Low Temp. Unit A Zone 1
T2A2	Low Temp. Unit A Zone 2
T2A3	Low Temp. Unit A Zone 3
T2A4	Low Temp. Unit A Zone 4
T2A5	Low Temp. Unit A Zone 5
T2A6	Low Temp. Unit A Zone 6
T2A7	Low Temp. Unit A Zone 7
T2A8	Low Temp. Unit A Zone 8
T2A9	Low Temp. Unit A Zone 9
T2AA	Low Temp. Unit A Zone 10
T2AB	Low Temp. Unit A Zone 11
T2AC	Low Temp. Unit A Zone 12
T2AD	Low Temp. Unit A Pump
T2AE	Low Temp. Unit A Platen
T2B1	Low Temp. Unit B Zone 1
T2B2	Low Temp. Unit B Zone 2
T2B3	Low Temp. Unit B Zone 3
T2B4	Low Temp. Unit B Zone 4
T2B5	Low Temp. Unit B Zone 5
T2B6	Low Temp. Unit B Zone 6
T2B7	Low Temp. Unit B Zone 7
T2B8	Low Temp. Unit B Zone 8
T2B9	Low Temp. Unit B Zone 9
T2BA	Low Temp. Unit B Zone 10
T2BB	Low Temp. Unit B Zone 11
T2BC	Low Temp. Unit B Zone 12
T2BD	Low Temp. Unit B Pump
T2BE	Low Temp. Unit B Platen
T2C1	Low Temp. MZLP 1
T2C2	Low Temp. MZLP 2
T2C3	Low Temp. MZLP 3
T2C4	Low Temp. MZLP 4
T2C5	Low Temp. MZLP 5
T2C6	Low Temp. MZLP 6
T2C7	Low Temp. MZLP 7
T2CG	Low Temp. Gateway
T2CV	Low Temp. AWB, Unit A
T2CW	Low Temp. AWB, Unit B

Appendix C - Error/Event Tables

<b>Error/Event Code</b>	<b>Description</b>
T2CX	Low Temp. System I/O, Unit A
T2CY	Low Temp. System I/O, Unit B
T3A1	High Temp. Unit A Zone 1
T3A2	High Temp. Unit A Zone 2
T3A3	High Temp. Unit A Zone 3
T3A4	High Temp. Unit A Zone 4
T3A5	High Temp. Unit A Zone 5
T3A6	High Temp. Unit A Zone 6
T3A7	High Temp. Unit A Zone 7
T3A8	High Temp. Unit A Zone 8
T3A9	High Temp. Unit A Zone 9
T3AA	High Temp. Unit A Zone 10
T3AB	High Temp. Unit A Zone 11
T3AC	High Temp. Unit A Zone 12
T3AD	High Temp. Unit A Pump
T3AE	High Temp. Unit A Platen
T3B1	High Temp. Unit B Zone 1
T3B2	High Temp. Unit B Zone 2
T3B3	High Temp. Unit B Zone 3
T3B4	High Temp. Unit B Zone 4
T3B5	High Temp. Unit B Zone 5
T3B6	High Temp. Unit B Zone 6
T3B7	High Temp. Unit B Zone 7
T3B8	High Temp. Unit B Zone 8
T3B9	High Temp. Unit B Zone 9
T3BA	High Temp. Unit B Zone 10
T3BB	High Temp. Unit B Zone 11
T3BC	High Temp. Unit B Zone 12
T3BD	High Temp. Unit B Pump
T3BE	High Temp. Unit B Platen
T3C1	High Temp. MZLP 1
T3C2	High Temp. MZLP 2
T3C3	High Temp. MZLP 3
T3C4	High Temp. MZLP 4
T3C5	High Temp. MZLP 5
T3C6	High Temp. MZLP 6
T3C7	High Temp. MZLP 7
T3CG	High Temp. Gateway
T3CV	High Temp. AWB, Unit A
T3CW	High Temp. AWB, Unit B
T3CX	High Temp. System I/O, Unit A

T3CY	High Temp. System I/O, Unit B
T4C1	High Temp. MZLP 1
T4C2	High Temp. MZLP 2
T4C3	High Temp. MZLP 3
T4C4	High Temp. MZLP 4
T4C5	High Temp. MZLP 5
T4C6	High Temp. MZLP 6
T4C7	High Temp. MZLP 7
T4CG	High Temp. Gateway
T4CV	High Temp. AWB, Unit A
T4CW	High Temp. AWB, Unit B
T4CX	High Temp. System I/O, Unit A
T4CY	High Temp. System I/O, Unit B
T4A1	High Temp. Unit A Zone 1
T4A2	High Temp. Unit A Zone 2
T4A3	High Temp. Unit A Zone 3
T4A4	High Temp. Unit A Zone 4
T4A5	High Temp. Unit A Zone 5
T4A6	High Temp. Unit A Zone 6
T4A7	High Temp. Unit A Zone 7
T4A8	High Temp. Unit A Zone 8
T4A9	High Temp. Unit A Zone 9
T4AA	High Temp. Unit A Zone 10
T4AB	High Temp. Unit A Zone 11
T4AC	High Temp. Unit A Zone 12
T4AD	High Temp. Unit A Pump
T4AE	High Temp. Unit A Platen
T4B1	High Temp. Unit B Zone 1
T4B2	High Temp. Unit B Zone 2
T4B3	High Temp. Unit B Zone 3
T4B4	High Temp. Unit B Zone 4
T4B5	High Temp. Unit B Zone 5
T4B6	High Temp. Unit B Zone 6
T4B7	High Temp. Unit B Zone 7
T4B8	High Temp. Unit B Zone 8
T4B9	High Temp. Unit B Zone 9
T4BA	High Temp. Unit B Zone 10
T4BB	High Temp. Unit B Zone 11
T4BC	High Temp. Unit B Zone 12
T4BD	High Temp. Unit B Pump
T4BE	High Temp. Unit B Platen
T4MA	High Temp. Transformer Unit A
T4MB	High Temp. Transformer Unit B

<b>Error/Event Code</b>	<b>Description</b>
T6A1	Sensor Err. Unit A Zone 1
T6A2	Sensor Err. Unit A Zone 2
T6A3	Sensor Err. Unit A Zone 3
T6A4	Sensor Err. Unit A Zone 4
T6A5	Sensor Err. Unit A Zone 5
T6A6	Sensor Err. Unit A Zone 6
T6A7	Sensor Err. Unit A Zone 7
T6A8	Sensor Err. Unit A Zone 8
T6A9	Sensor Err. Unit A Zone 9
T6AA	Sensor Err. Unit A Zone 10
T6AB	Sensor Err. Unit A Zone 11
T6AC	Sensor Err. Unit A Zone 12
T6AD	Sensor Err. Unit A Pump
T6AE	Sensor Err. Unit A Platen
T6B1	Sensor Err. Unit B Zone 1
T6B2	Sensor Err. Unit B Zone 2
T6B3	Sensor Err. Unit B Zone 3
T6B4	Sensor Err. Unit B Zone 4
T6B5	Sensor Err. Unit B Zone 5
T6B6	Sensor Err. Unit B Zone 6
T6B7	Sensor Err. Unit B Zone 7
T6B8	Sensor Err. Unit B Zone 8
T6B9	Sensor Err. Unit B Zone 9
T6BA	Sensor Err. Unit B Zone 10
T6BB	Sensor Err. Unit B Zone 11
T6BC	Sensor Err. Unit B Zone 12
T6BD	Sensor Err. Unit B Pump
T6BE	Sensor Err. Unit B Platen
T6C1	Sensor Err. MZLP 1
T6C2	Sensor Err. MZLP 2
T6C3	Sensor Err. MZLP 3
T6C4	Sensor Err. MZLP 4
T6C5	Sensor Err. MZLP 5
T6C6	Sensor Err. MZLP 6
T6C7	Sensor Err. MZLP 7
T6CG	Sensor Err. Gateway
T6CV	Sensor Err. AWB, Unit A
T6CW	Sensor Err. AWB, Unit B
T6CX	Sensor Err. System I/O, Unit A
T6CY	Sensor Err. System I/O, Unit B
T8A1	No Temp. Rise Unit A Zone 1

T8A2	No Temp. Rise Unit A Zone 2
T8A3	No Temp. Rise Unit A Zone 3
T8A4	No Temp. Rise Unit A Zone 4
T8A5	No Temp. Rise Unit A Zone 5
T8A6	No Temp. Rise Unit A Zone 6
T8A7	No Temp. Rise Unit A Zone 7
T8A8	No Temp. Rise Unit A Zone 8
T8A9	No Temp. Rise Unit A Zone 9
T8AA	No Temp. Rise Unit A Zone 10
T8AB	No Temp. Rise Unit A Zone 11
T8AC	No Temp. Rise Unit A Zone 12
T8AD	No Temp. Rise Unit A Pump
T8AE	No Temp. Rise Unit A Platen
T8B1	No Temp. Rise Unit B Zone 1
T8B2	No Temp. Rise Unit B Zone 2
T8B3	No Temp. Rise Unit B Zone 3
T8B4	No Temp. Rise Unit B Zone 4
T8B5	No Temp. Rise Unit B Zone 5
T8B6	No Temp. Rise Unit B Zone 6
T8B7	No Temp. Rise Unit B Zone 7
T8B8	No Temp. Rise Unit B Zone 8
T8B9	No Temp. Rise Unit B Zone 9
T8BA	No Temp. Rise Unit B Zone 10
T8BB	No Temp. Rise Unit B Zone 11
T8BC	No Temp. Rise Unit B Zone 12
T8BD	No Temp. Rise Unit B Pump
T8BE	No Temp. Rise Unit B Platen
T8C1	No Temp. Rise MZLP 1
T8C2	No Temp. Rise MZLP 2
T8C3	No Temp. Rise MZLP 3
T8C4	No Temp. Rise MZLP 4
T8C5	No Temp. Rise MZLP 5
T8C6	No Temp. Rise MZLP 6
T8C7	No Temp. Rise MZLP 7
T8CG	No Temp. Rise Gateway
T8CV	No Temp. Rise AWB, Unit A
T8CW	No Temp. Rise AWB, Unit B
T8CX	No Temp. Rise System I/O, Unit A
T8CY	No Temp. Rise System I/O, Unit B
TAAX	Over Temp Switch Unit A
TABX	Over Temp Switch Unit B
V1I1	Low Voltage 24VDC MZLP 1
V1I2	Low Voltage 24VDC MZLP 2

<b>Error/Event Code</b>	<b>Description</b>
V1I3	Low Voltage 24VDC MZLP 3
V1I4	Low Voltage 24VDC MZLP 4
V1I5	Low Voltage 24VDC MZLP 5
V1I6	Low Voltage 24VDC MZLP 6
V1I7	Low Voltage 24VDC MZLP 7
V1IG	Low Voltage 24VDC Gateway
V1IV	Low Voltage 24VDC AWB, Unit A
V1IW	Low Voltage 24VDC AWB, Unit B
V1IX	Low Voltage 24VDC System I/O, Unit A
V1IY	Low Voltage 24VDC System I/O, Unit B
V1M1	Low Voltage Line MZLP 1
V1M2	Low Voltage Line MZLP 2
V1M3	Low Voltage Line MZLP 3
V1M4	Low Voltage Line MZLP 4
V1M5	Low Voltage Line MZLP 5
V1M6	Low Voltage Line MZLP 6
V1M7	Low Voltage Line MZLP 7
V1MG	Low Voltage Line Gateway
V1MV	Low Voltage Line AWB, Unit A
V1MW	Low Voltage Line AWB, Unit B
V1MX	Low Voltage Line System I/O, Unit A
V1MY	Low Voltage Line System I/O, Unit B
V4I1	High Voltage 24VDC MZLP 1
V4I2	High Voltage 24VDC MZLP 2
V4I3	High Voltage 24VDC MZLP 3
V4I4	High Voltage 24VDC MZLP 4
V4I5	High Voltage 24VDC MZLP 5
V4I6	High Voltage 24VDC MZLP 6
V4I7	High Voltage 24VDC MZLP 7
V4IG	High Voltage 24VDC Gateway
V4IV	High Voltage 24VDC AWB, Unit A
V4IW	High Voltage 24VDC AWB, Unit B
V4IX	High Voltage 24VDC System I/O, Unit A
V4IY	High Voltage 24VDC System I/O, Unit B
V4M1	High Voltage Line MZLP 1
V4M2	High Voltage Line MZLP 2
V4M3	High Voltage Line MZLP 3
V4M4	High Voltage Line MZLP 4
V4M5	High Voltage Line MZLP 5
V4M6	High Voltage Line MZLP 6
V4M7	High Voltage Line MZLP 7

V4MG	High Voltage Line Gateway
V4MV	High Voltage Line AWB, Unit A
V4MW	High Voltage Line AWB, Unit B
V4MX	High Voltage Line System I/O, Unit A
V4MY	High Voltage Line System I/O, Unit B
V6I1	Wiring Error 24VDC MZLP 1
V6I2	Wiring Error 24VDC MZLP 2
V6I3	Wiring Error 24VDC MZLP 3
V6I4	Wiring Error 24VDC MZLP 4
V6I5	Wiring Error 24VDC MZLP 5
V6I6	Wiring Error 24VDC MZLP 6
V6I7	Wiring Error 24VDC MZLP 7
V6IG	Wiring Error 24VDC Gateway
V6IV	Wiring Error 24VDC AWB, Unit A
V6IW	Wiring Error 24VDC AWB, Unit B
V6IX	Wiring Error 24VDC System I/O, Unit A
V6IY	Wiring Error 24VDC System I/O, Unit B
V6M1	Wiring Error Line MZLP 1
V6M2	Wiring Error Line MZLP 2
V6M3	Wiring Error Line MZLP 3
V6M4	Wiring Error Line MZLP 4
V6M5	Wiring Error Line MZLP 5
V6M6	Wiring Error Line MZLP 6
V6M7	Wiring Error Line MZLP 7
V6MG	Wiring Error Line Gateway
V6MV	Wiring Error Line AWB, Unit A
V6MW	Wiring Error Line AWB, Unit B
V6MX	Wiring Error Line System I/O, Unit A
V6MY	Wiring Error Line System I/O, Unit B
V8I1	No Voltage 24VDC MZLP 1
V8I2	No Voltage 24VDC MZLP 2
V8I3	No Voltage 24VDC MZLP 3
V8I4	No Voltage 24VDC MZLP 4
V8I5	No Voltage 24VDC MZLP 5
V8I6	No Voltage 24VDC MZLP 6
V8I7	No Voltage 24VDC MZLP 7
V8IG	No Voltage 24VDC Gateway
V8IV	No Voltage 24VDC AWB, Unit A
V8IW	No Voltage 24VDC AWB, Unit B
V8IX	No Voltage 24VDC System I/O, Unit A
V8IY	No Voltage 24VDC System I/O, Unit B
V8M1	No Voltage Line MZLP 1
V8M2	No Voltage Line MZLP 2

<b>Error/Event Code</b>	<b>Description</b>
V8M3	No Voltage Line MZLP 3
V8M4	No Voltage Line MZLP 4
V8M5	No Voltage Line MZLP 5
V8M6	No Voltage Line MZLP 6
V8M7	No Voltage Line MZLP 7
V8MG	No Voltage Line Gateway
V8MV	No Voltage Line AWB, Unit A
V8MW	No Voltage Line AWB, Unit B
V8MX	No Voltage Line System I/O, Unit A
V8MY	No Voltage Line System I/O, Unit B
WJ1A	Solenoid Error No Current Unit A
WJ1B	Solenoid Error No Current Unit B
WJ2A	Solenoid Error High Current Unit A
WJ2B	Solenoid Error High Current Unit B
WSUX	Config. Error USB

# Graco Information

## Sealant and Adhesive Dispensing Equipment

For the latest information about Graco products, visit [www.graco.com](http://www.graco.com).

For patent information, see [www.graco.com/patents](http://www.graco.com/patents).

**TO PLACE AN ORDER**, contact your Graco distributor, go to [www.graco.com](http://www.graco.com), or call to identify the nearest distributor.

**If calling from the USA:** 1-800-746-1334

**If calling from outside the USA:** 0-1-330-966-3000

*All written and visual data contained in this document reflects the latest product information available at the time of publication.  
Graco reserves the right to make changes at any time without notice.*

Original instructions. This manual contains English. MM 3A5186

**Graco Headquarters:** Minneapolis

**International Offices:** Belgium, China, Japan, Korea

**GRACO INC. AND SUBSIDIARIES • P.O. BOX 1441 • MINNEAPOLIS MN 55440-1441 • USA**  
**Copyright 2016, Graco Inc. All Graco manufacturing locations are registered to ISO 9001.**

[www.graco.com](http://www.graco.com)  
Revision C, December 2021